

FEMALE CONTACT CAT. N°	FIG.	Z	Y	WIRE SIZE		WIRE INSUL. DIAM. IN MM.	WIRE STRIP LENGTH IN MM.	HAND CRIMP TOOLING		EXTRACTION TOOL
				AWG	MM ²			DIE SET	HANDTOOL FOR LOOSE PIECE	
SC24M1* / SC24M1*REV	4A			26/24	0.12/0.25	0.90/1.60	4.0			RX2025GE1
SC24ML1*	4B							S16SCM20	SHANGLES	
SC20M1* / SC20M1*REV	3A			22/20	0.32/0.50	1.20/2.10	4.0			
SC20ML1*	3B							S16SCM20	SHANGLES	
SC16M11* / SC16M11*REV	2A			18/16	0.82/1.50	3.0 Max	4.65			
SC16ML11*	2B							S16SCML11	SHANGLES	
SC16M1* / SC16M1*REV	1A	2.87	2.3	18/16	0.82/1.50	3.2 Max	6.35			
SC16ML1*	1B							S16SCML1	SHANGLES	
SC14M1* / SC14M1*REV	1A	3.3	3.3	14	2.10/2.50	3.2 Max	6.35			
SC14ML1*	1B							S16SCML1	SHANGLES	

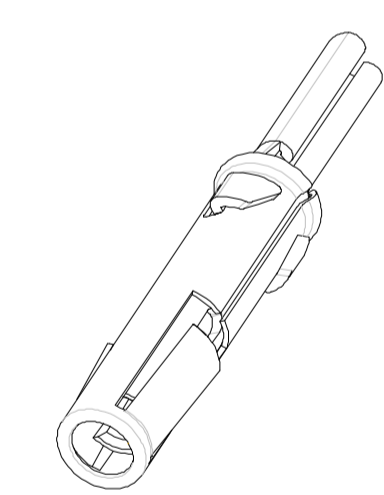

*** PLATING**

: S6 = 0.75 μ GOLD MIN. OVER Ni (AREA 1)
 : GOLD FLASH OVER Ni (AREA 2)
 : D70 = 0.13 μ GOLD MIN. OVER Ni (AREA 1) For standard winding
 : GOLD FLASH OVER Ni (AREA 2)
 : TK6 = 0.5-2.5 μ Sn PRE-PLATED (AREA 1 + 2)

SEE FIG.1B-2B-3B-4B

: S18 = 0,75 μ GOLD MIN OVER Ni (AREA 1)
 1,3 μ MINI Sn OVER Ni (AREA 3)
 1,3 μ MINI Ni (AREA 4)
 : S31 = GOLD FLASH OVER Ni (AREA 1)
 1,3 μ MINI Sn OVER Ni (AREA 3) For standard winding only
 1,3 μ MINI Ni (AREA 4)
 : D70REV = 0.13 μ GOLD MIN. OVER Ni (AREA 1)
 1,3 μ MINI Sn OVER Ni (AREA 3) For reverse winding
 1,3 μ MINI Ni (AREA 4)

SEE FIG.1B-2B-3B-4B

CONSTRUCTION

CONTACT BODY : HIGH CONDUCTIVITY COPPER ALLOY.
 OUTER SPRING : STAINLESS STEEL.

PACKING CONTACTS ON STANDARD STRIP : 3000 PCS. PER REEL, E.G. SC16M11*
 PACKING CONTACTS ON REVERSE STRIP : 3000 PCS. PER REEL, E.G. SC16M11*REV
 FOR WINDING DIRECTION ON REEL (STANDARD OR REVERSE) : SEE BS.C.202338.004
 PACKING LOOSE PIECE CONTACTS : 100 PCS PER STD. PACKING. E.G. SC16ML11*

CONNECTOR ACCOMMODATION

THESE CONTACTS CAN BE USED IN ANY CONTACT POSITION IN ANY CONNECTOR IN THE TRIM TRIO INTERCONNECTION SYSTEM : M5M - M5G - MB RECTANGULAR CONN. , S5S QIKMATE CONN. , UTO - UTS - UTL - UTG AND UTP - MBG CIRCULAR CONN.

PERFORMANCE CHARACTERISTICS

CURRENT RATING : 13 A
 CONTACT RESISTANCE : <= 6 m Ohm
 OPERATING VOLTAGE : 750 V RMS
 CONTACT RETENTION IN BODY : 65 N MIN.
 INDIVIDUAL INSERTION FORCE : 3.5 N MAX.
 INDIVIDUAL WITHDRAWAL FORCE : 0.55 N MIN.

Country	Jurisdiction & Control_List
FR	NOT LISTED

CUSTOMER DRAWING

E	24/10/16	Update of the cartridge	TESSIER		-
IND	DATE	LIBELLE	EMIS PAR	CONTROLE PAR	N°DIFFUSION
DEFINI PAR : R. Verbeek		LE:11-06-86	TYPE DE PLAN: CUSTOMER DRAWING		
VERIFIE PAR: -		LE:-			
LES COTES S'ENTENDENT AVANT PROTECTION / FINITION					
DENOMINATION: FEMALE FORMED TWO PIECE CONTACT SC--M---					
ECHELLE	TOLERANCES GENERALES	MATIERE: -	N°:-		
1/1	ANGULAIRES: +- *	-			
	LINEAIRES: +- *	PROTECTION: -	CODE:-		
USINAGE GENERAL	ETAT DE SURFACE	DEFAUTS DE GEOMETRIE	REFERENCE MATERIEL	AFFAIRE	
		VOIR NF E 04-552	-	IT	
www.souriau.com		CE DOCUMENT EST LA PROPRIETE DE SOURIAU IL NE PEUT ETRE REPRODUIT OU COMMUNIQUE SANS SON AUTORISATION			
FORMAT	REFERENCE PLAN				FOLIO
A1	BS-C-200178-002				1/1