

PRODUCT NUMBER: 852-90-010-20-001000

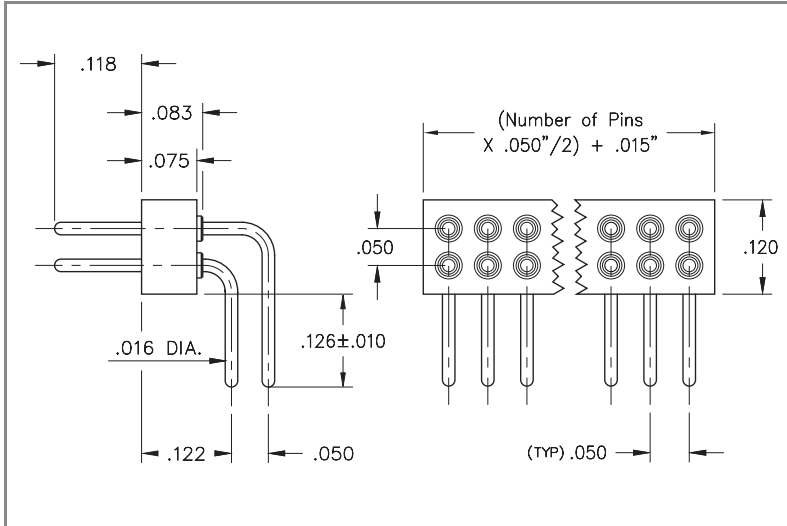

DESCRIPTION

Interconnect Machined Pin Header
 Right Angle Pin Header
 .016" (0,406mm) Pin Head
Rows: Double Row (2)
Pitch: .050" (1,270mm)
Clip Grid: 20
Pin Window Pattern 001
Plating Code: 90
Shell: 200 μ" Tin/Lead(93/7) over 100 μ" Nickel
Insulator Pin Clip Type: 000
Mounting Type: Through Hole Solder Mount
Insulator Information:
 Nylon 46 High Temperature

Pins

10

LOOSE PIN/RECEPTACLE USED:

4006 (Brass Alloy)

BRASS ALLOY 360 per ASTM B 16, or 385 per ASTM B455

Properties of BRASS ALLOY 360 ASTM B 16:

- Chemical composition: Cu 63% (max), Pb 3.7% (max)†, Fe .35% (max), Zn remainder
- Temper as machined: H02/H04
- Yield Strength: 25-45 ksi
- Tensile strength: 57-80 ksi
- Hardness as machined: 80-90 Rockwell B
- Electrical conductivity: 26% IACS*
- Melting point: 1000°C/840°C (liquidus/solidus)

Properties of BRASS ALLOY 385 ASTM B 455:

- Chemical composition: Cu 60% (max), Pb 3.5% (max)†, Fe .35% (max), Zn remainder
- Temper as machined: H02/H04
- Yield Strength: 16 ksi(min)
- Tensile strength: 48 ksi(min)
- Hardness as machined: 80-90 Rockwell B
- Electrical conductivity: 28% IACS*
- Melting point: 1000°C/840°C (liquidus/solidus)

After machining, brass parts are often annealed (softened) for subsequent bending, swaging or crimping. A partial anneal down to 60±10 RB is recommended for 90° bends, a full anneal down to 35±15 RB is recommended for pins or terminals that are swaged (riveted) to a circuit board or crimped to a wire.

Note: Plated Brass parts need a barrier plate to prevent zinc diffusion, 50 μ " min. nickel or 100 μ " min. copper is recommended by ASTM B 545 and 579. ASTM B 488 also recommends a 50 μ " min. nickel barrier plate beneath gold to prevent copper diffusion inherent with all copper alloy products.

†RoHS-2 directive 2011/65/EU, exemption 6c allows up to 4% lead as an alloy agent in copper.

*International Annealed Copper Standard, i.e. as a % of pure copper.

INSULATOR MATERIAL:

Nylon 46 (Injection Molded)

Properties:

- High Temp. {30% glass filled} or {45% glass filled}, (black). Flammability rating UL 94 V-0
- Material Heat Deflection Temp. (per ASTM D 648): 554°F (290°C) @ 264 psi

Note: Materials with HDT above 446°F (230°C) are considered suitable for "eutectic" reflow soldering. For "lead-free" reflow soldering, choose materials with an HDT above 500°F (260°C).

STANDARD TOLERANCES ON PCB TERMINAL PINS & RECEPTACLES

Diameters +/- .002"

Lengths +/- .005"

Angles +/- 2°

ADDITIONAL NOTES & SPECIFICATIONS

In the interest of improved design, quality and performance, Mill-Max reserves the right to make changes in its specifications without prior notice. Specifications and tolerances are provided wherever possible. The tolerance on dimensions of critical to function features is typically held tighter than the stated standard tolerances, such as press-fits, holes and lengths affecting the coplanarity of SMT products. Due to the wide variety of interconnects Mill-Max offers, the specific tolerances vary from product to product. If you need information regarding the tolerance of a particular part, please contact Technical Services.

 © 2021 Mill-Max Mfg. Corp.

190 Pine Hollow Rd, Oyster Bay, NY 11771, USA

Phone: 516.922.6000