

SECTION C-C

SECTION D-D

spec ref	-	dr	Tim Houtz	2010/04/08	projection	MM	size	A2	scale	4:1
tolerance std	ASME Y14.5	eng	Feng Zheng	2016/12/22			ecn no	ELX-DG-25730-1	rel level	Released
TOLERANCES UNLESS OTHERWISE SPECIFIED		chr	Terris Liu	2016/12/23			product family	CARD EDGE		rel level
surface	linear	0.X	±0.3		title		VERT RECT (36P 24S)		cat. no. - Product - Customer Drw sheet 1 of 4	rev C
		0.XX	±0.1		www.fci.com		10114587			
	angular	0°	±2°		cat. no.		-			

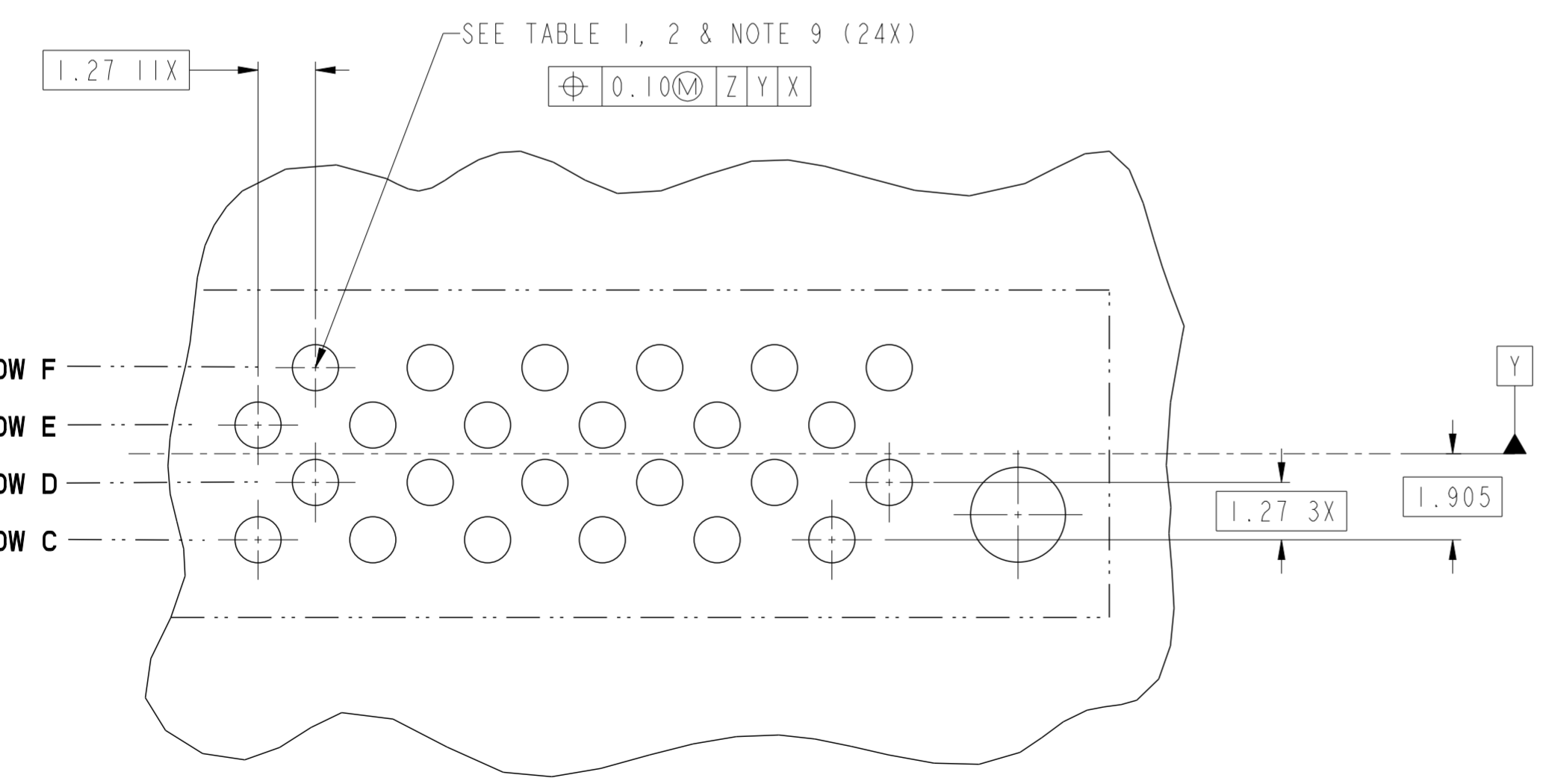
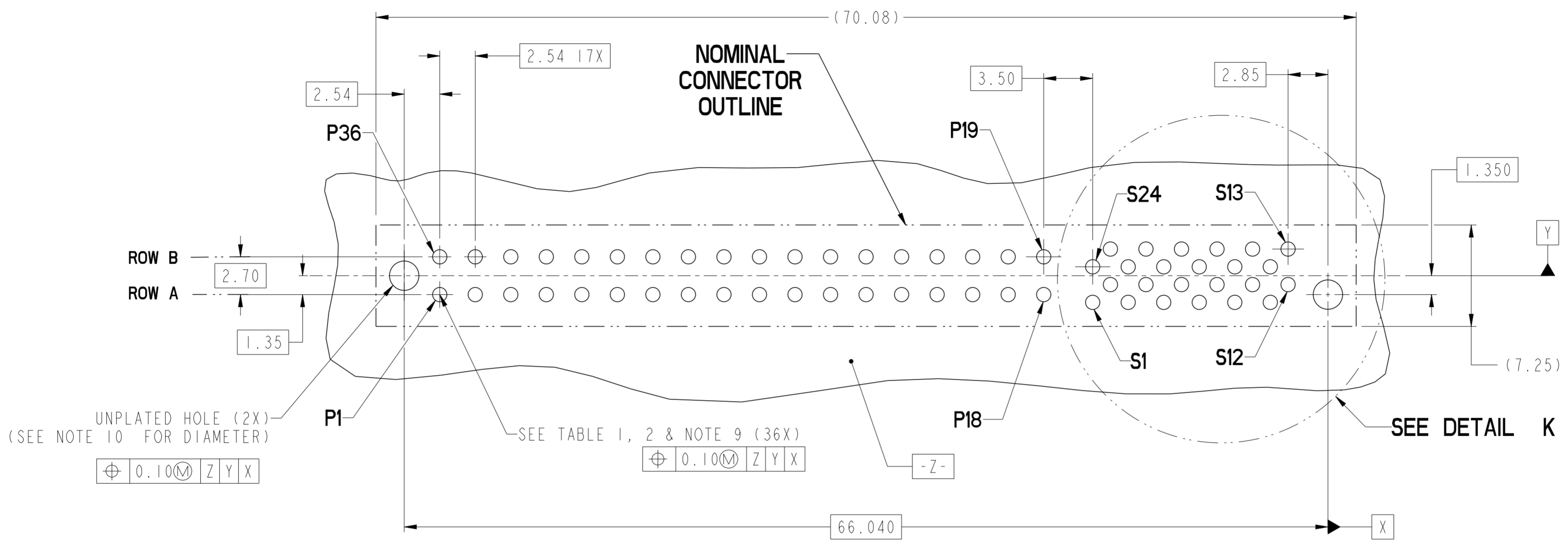

DETAIL K
SCALE 8:1

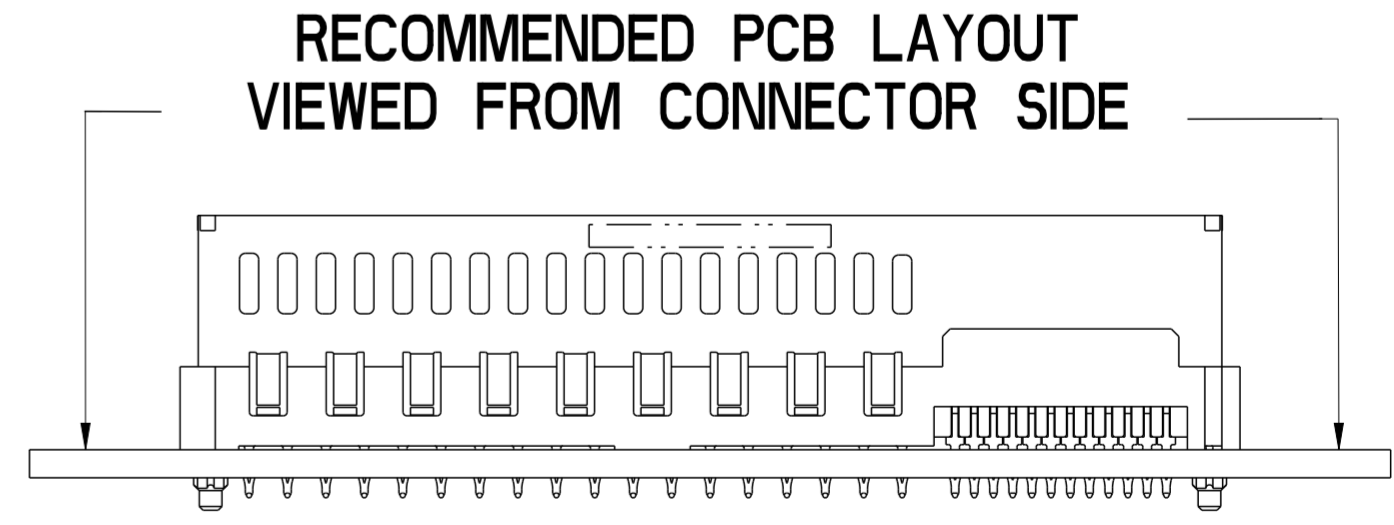

spec ref	-	dr	Tim Houtz	2010/04/08	projection	MM	size	A2	scale	4:1		
tolerance std	ASME Y14.5	eng	Feng Zheng	2016/12/22			ecn no	ELX-DG-25730-1	rel level	Released		
TOLERANCES UNLESS OTHERWISE SPECIFIED		chr	Terris Liu	2016/12/23			product family	CARD EDGE		rel level	Released	
surface	-	appr	Pai-Ming Zheng	2016/12/23	Amphenol FCI VERT RECT (36P 24S) HIGH POWER CARD EDGE		cat. no.	10114587	sheet 2 of 4	rev	C	
ASME Y14.5	linear	0.X	±0.3	0.XX	±0.1	0.XXX	±0.05	angular	0°	±2°	Product - Customer Drw	

CONTACT TYPE	TOP LAYER DESCRIPTION	TABLE 1 (HPCE / SOLDER TAILS) PLATED THROUGH-HOLE REQUIREMENTS				
		DRILLED HOLE DIAMETER	COPPER THICKNESS	TIN-LEAD THICKNESS	TIN THICKNESS	FINISHED HOLE DIAMETER
POWER & SIGNAL	TIN-LEAD	1.10-1.16 (1.15 DRILL)	0.025 - 0.050	0.005 - 0.015	--	0.94 - 1.10
	IMMERSION TIN	1.10-1.16 (1.15 DRILL)	0.025 - 0.050	--	0.9 - 1.5um	0.94 - 1.10
	COPPER (SEE NOTE 8)	1.10-1.16 (1.15 DRILL)	0.025 - 0.050	--	--	0.94 - 1.10

CONTACT TYPE	TOP LAYER DESCRIPTION	TABLE 2 (HPCE / PRESS-FIT TAILS) PLATED THROUGH-HOLE REQUIREMENTS				
		DRILLED HOLE DIAMETER	COPPER THICKNESS	TIN-LEAD THICKNESS	TIN THICKNESS	FINISHED HOLE DIAMETER
POWER & SIGNAL	TIN-LEAD	0.81-0.86 (0.85 DRILL)	0.025 - 0.050	0.005 - 0.015	--	0.65 - 0.80
	IMMERSION TIN	0.81-0.86 (0.85 DRILL)	0.025 - 0.050	--	0.9 - 1.5um	0.70 - 0.80
	COPPER (SEE NOTE 8)	0.81-0.86 (0.85 DRILL)	0.025 - 0.050	--	--	0.70 - 0.80

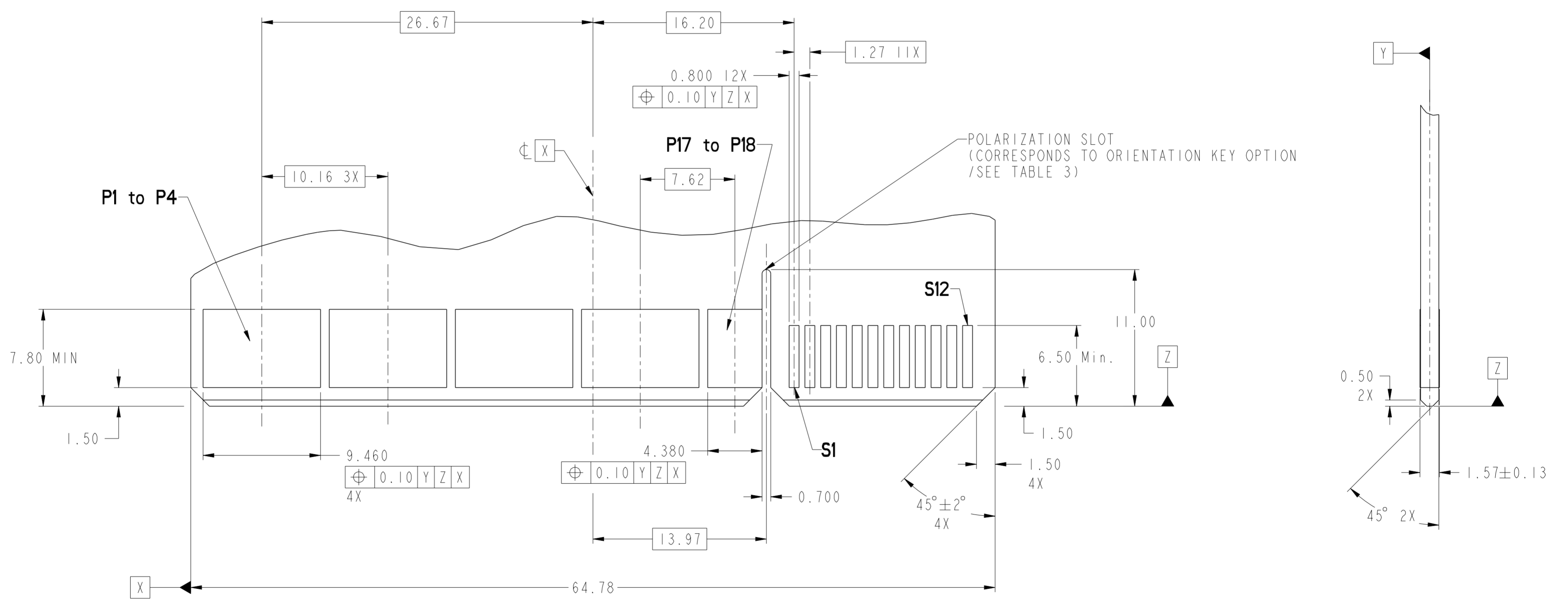

RECOMMENDED MATING BOARD FOOTPRINT

dr	Tim Houtz	2010/04/08	projection	MM	size	A2	scale	4:1
eng	Feng Zheng	2016/12/22			ecn no	ELX-DG-25730-1	rel level	Released
chr	Terris Liu	2016/12/23			product family	CARD EDGE		dwg no
appr	Pai-Ming Zheng	2016/12/23	www.fci.com		cat. no.	-	Product - Customer Drw	sheet 3 of 4

HPCE PART NUMBER (TABLE 3)

PART NUMBER	TAIL TYPE	ORIENTATION KEY	DIM "A" TYPICAL TAIL LENGTH	DIM "B" TYPICAL TAIL LENGTH	DIM "C" RECOMMENDED BOARD THICKNESS
10114587-001LF	SOLDER	YES	3.17 ±0.25	3.17 ±0.25	1.59 - 2.38
10114587-002LF	SOLDER	NO			
10114587-003	PRESS-FIT	YES	3.17 ±0.25	3.17 ±0.25	1.57 MIN
10114587-003LF	PRESS-FIT	YES			
10114587-004	PRESS-FIT	NO			
10114587-004LF	PRESS-FIT	NO	4.05 ±0.25	3.75 ±0.25	3.20±0.18
10114587-005LF [△]	SOLDER	YES			
10114587-006LF [△]	SOLDER	NO			

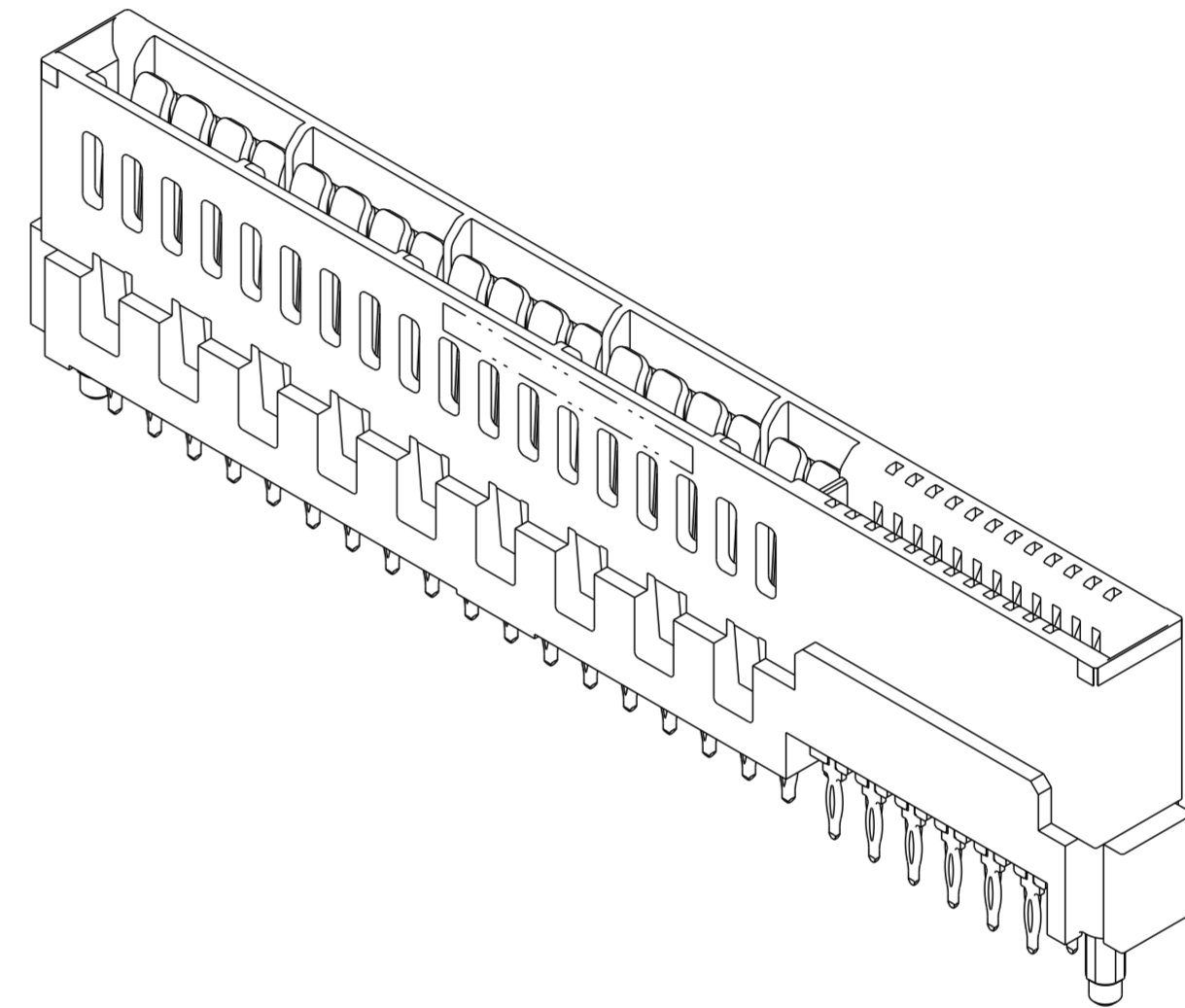

NOTES:

- CONNECTOR MATERIALS:
 HOUSING: HIGH TEMPERATURE THERMAL PLASTIC, BLACK
 UL 94V-0 COMPLIANT
 CONTACTS: HIGH PERFORMANCE COPPER ALLOY.
- CONTACT FINISH REF. GS-12-604 SECTION 5.2.
- PRODUCT SPECIFICATION: GS-12-604.
- APPLICATION SPECIFICATION: GS-20-128.
- PRODUCT MARKING (FCI - PART NUMBER & DATE CODE) ON HOUSING IN AREA SHOWN.
- PACKAGING MEETS FCI SPECIFICATION GS-14-937.
- HOUSING COMPONENT WILL WITHSTAND EXPOSURE TO 260°C PEAK TEMPERATURE FOR 60 SECONDS IN A CONVECTION, INFRA-RED, OR VAPOR PHASE REFLOW OVEN.
- COPPER PLATING THICKNESS IN CENTER OF VIA-HOLE CAN BE NO MORE THAN 0.003 LESS THAN OTHER AREAS.
- ALL HOLE SIZES ARE FINISHED HOLE SIZES.
- MOUNTING HOLES ARE UNPLATED
 Ø 2.40 +/- 0.1 FOR PRESS-FIT TAILS
 Ø 2.10 +/- 0.1 FOR SOLDER TAILS
- A [△]SYMBOL WILL BE NEXT TO ANY DIMENSION, VIEW, OR NOTE WHICH HAS BEEN MODIFIED WITH THE CURRENT DRAWING REVISION.

dr	Tim Houtz	2010/04/08	projection	MM	size	A2	scale	4:1
eng	Feng Zheng	2016/12/22			ecn no	ELX-DG-25730-1		
chr	Terris Liu	2016/12/23			product family	CARD EDGE	rel level	Released
appr	Pai-Ming Zheng	2016/12/23	Amphenol FCI VERT RECT (36P 24S) HIGH POWER CARD EDGE		www.fci.com cat. no.	10114587	rev C	Product - Customer Drw sheet 4 of 4