

AKUSENSE

# AS-33C LiDAR Sensor User Manual



V1.0

## **Catalog**

1 Product Introduction .....	3
2 Parameter Indicators .....	4
3 Equipment installation .....	6
4 Electrical connections .....	9
5 Software Operation Method .....	17
6 Specification .....	24

# 1 Product Introduction

AS-33C lidar is a single-line obstacle avoidance lidar product launched by Akusense. This series of Lidars use the pulsed time of flight method (PulsedToF) for distance measurement, and its internal structure adopts a rotating mirror design, that is, the invisible infrared laser emitted by the ranging module is deflected to different angles through a high-speed rotating mirror surface, so as to realize the Scanning measurement of environmental profiles within 270° of the same horizontal plane. Compared with similar products, AS-33C lidar has the following characteristics:

- ① Long measurement distance: Due to the principle of pulse ranging and the optimization of optoelectronic design, the AS-33C series has a longer measurement distance for targets with the same reflectivity ( $\geq 10\text{m}@70\%$  reflectivity);
- ② Good reliability: The rotating mirror design minimizes the moving parts inside the Lidar, improves the service life and greatly reduces the impact of mechanical vibration on the operation;
- ③ Small size: the height of the Lidar body is not high. Over 7.2 cm and the base is only 5 cm long, making it easy to install in space-constrained situations.

## 2 Parameter Indicators

Model	AS-33C
Ranging Principle	PulsedToF
Laser Wavelength	905 nm
Maximum Detection Distance	10 m (70% reflectivity) / 4 m (10% reflectivity)
Detecting Scope	270°
Data Sampling Rate	18 KHz / 54 KHz
Angular resolution	0.5°
Ranging Accuracy	±2 cm (within 10 m )
Response time	40 ms
Start Time	< 10 s
Number of channels	64 (3 detection areas per channel)
Detection output delay	Can be set in the range of 0 - 2 s
Detection Hold Delay	Can be set in the range of 0 - 2 s
Detection size 0 - 5°	0 - 5° range can be set
Switch input	6 (NPN)
Switch output	4 (3 zone signals, 1 fault signal)
indicator light	4 (3 zone signals, 1 fault signal)

Communication interface	USB-TYPE C (serial port)
Power supply	DC 9 V - 28 V
Power consumption	Rated power: < 1 W (no load) Starting power:< 3 W (no load)
Operating temperature	-10 °C to 50 °C
Storage temperature	-20 °C to 70 °C
Ambient humidity	below 85%, no condensation
Protection class	IP65
Anti-ambient light	80000 Lux
Weight	171 g
Dimensions	50 mm(L) * 50 mm(W) * 72 mm(H)

## 3 Equipment installation

### 3.1 Installation environment

Lidar is a precision photoelectric sensing device. When installing, please keep the outer surface of the light-emitting area of the infrared cover clean to avoid contamination and scratches, so as not to block the field of view or generate noise. The laser transmitting and receiving area of the AS-33C in the vertical direction is shown in Figure 3-1. When installing, please refer to the area marked with slashes in Figure 3-1, and reserve at least 5 mm of vertical open space at the top and bottom to ensure that the laser emission and reception are not blocked.

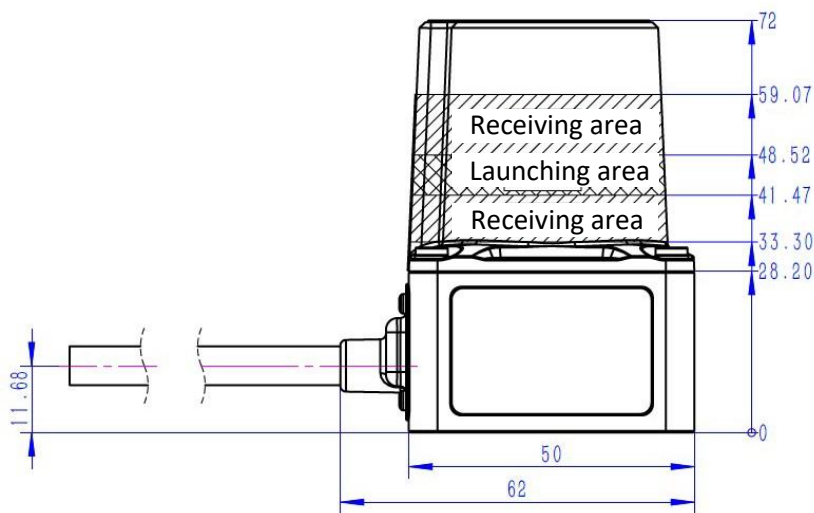

Figure 3-1 Location of laser transmitting and receiving area

The working area of AS-33C in the horizontal direction is  $270^{\circ}$ , that is,  $135^{\circ}$  on the left and right in front of the body, as shown in Figure 3-2.

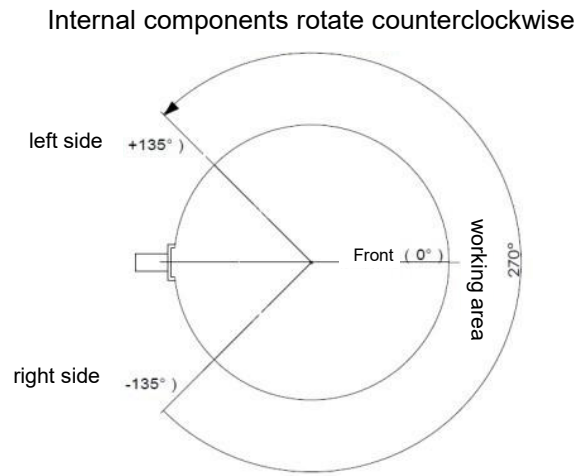

Figure 3-2 Field of view range of Lidar (top view)

## 3.2 Fixing method

AS-33C has threaded mounting holes at the bottom of the shell, the specific dimensions are shown in Figure 3-3

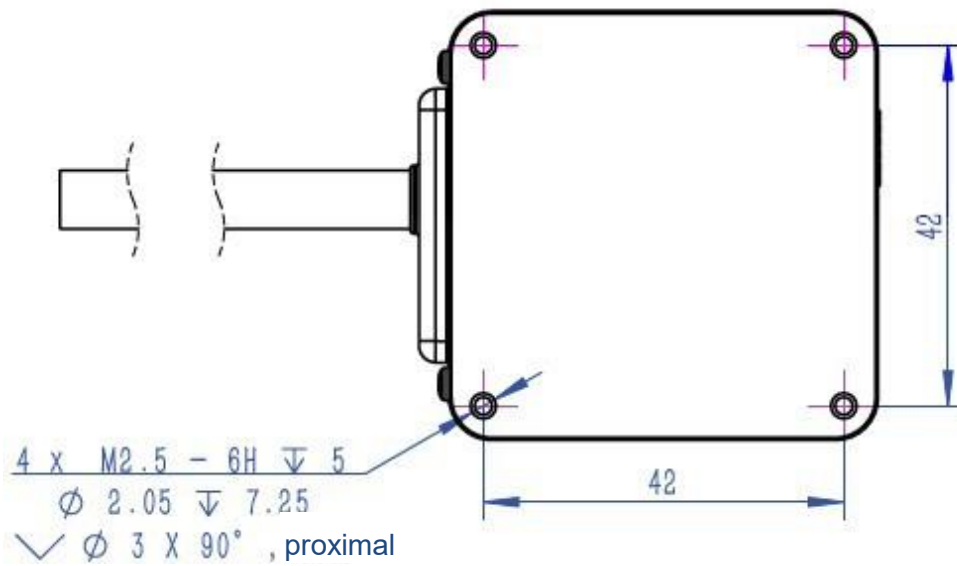

Figure 3-3 Mounting holes at the bottom of the housing



## 4 Electrical connections

### 4.1 Cable Definition

The sensor cable leads out 14-core wires, and its tail is shown in Figure 4-1, and the wire definitions are shown in Table 1.

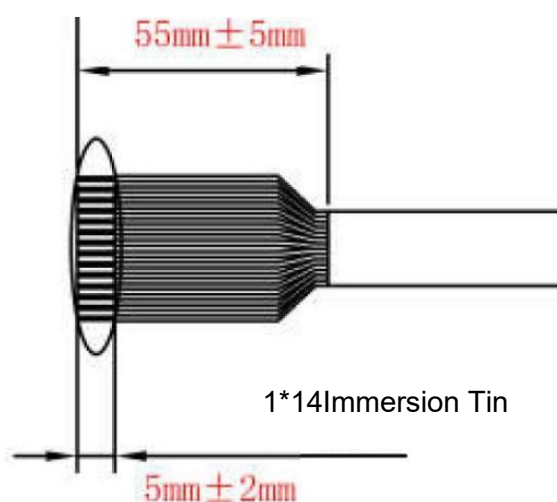

Figure 4-1 Outgoing diagram of cable tail

No.	Signal Type	Function	Color
1	Power supply	DC 9 V-28 V	Red
2	Power supply	DC GND	Black
3	Input	IN COM: Input common terminal, connect to the positive pole of the power supply	Brown

4	IN 1	Input port 1	red and white
5	IN 2	Input port 2	Orange-white
6	IN 3	Input port 3	Black and white
7	IN 4	Input port 4	Gray
8	IN 5	Input port 5	Brown white
9	IN 6	Input port 6	Orange
10	Output	OUT COM:output common terminal, connected to the negative pole of the power supply	white
11	OUT1	Port action when the attention zone senses an object	Yellow
12	OUT2	Port action when an object is detected in the early warning zone	Green
13	OUT3	When the alarm zone detects an object, the port acts	blue
14	Error OUT	Port action when sensor fails	Purple

## 4.2 Power Connection

Access to the power supply: DC 9 V-28 V  $\pm$  5%; In the AGV system or other power equipment network, a voltage stabilizer needs to be added to ensure that the interference of the power supply will not affect the normal operation of the sensor, and ensure that the output power of the power supply supports 2.5W Above (12V input, the load current is greater than 200mA)

## 4.3 Input and output signal connection

Input signal connection

The input is an open-collector (NPN) signal, as shown in Figure 4-2, using an optocoupler to isolate the input. Use external power supply: COM+ input DC 9 V~28 V $\pm$ 20%, more than 50mA, as shown in Figure 4-3

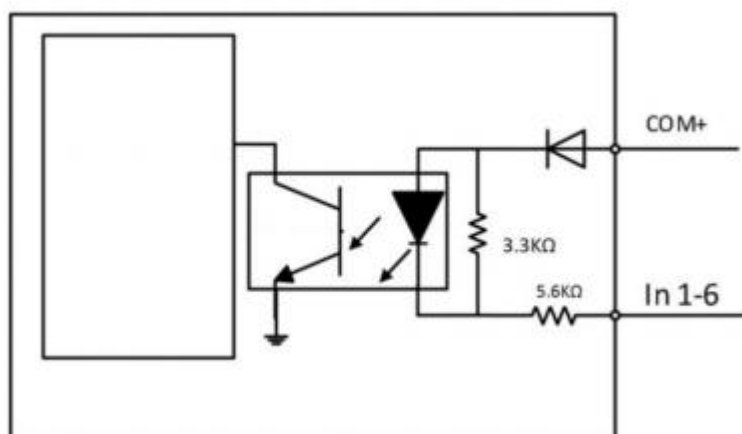

Figure 4-2 Input Schematic

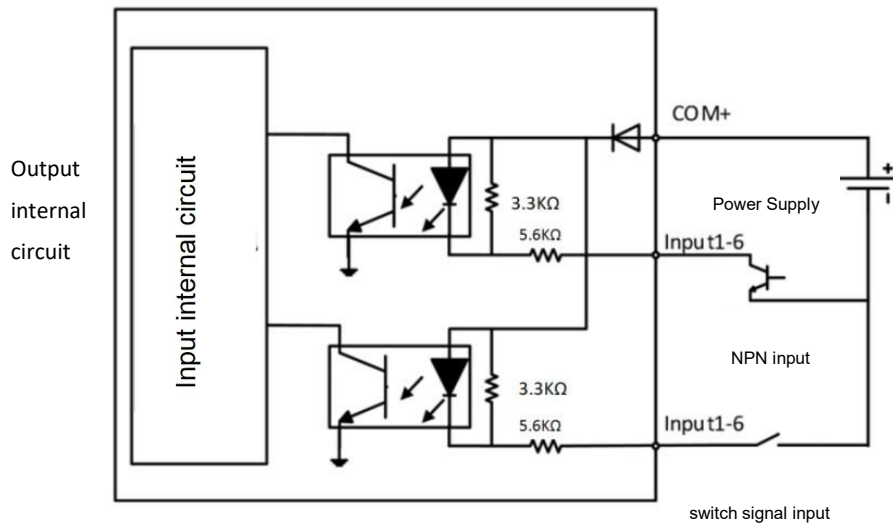

Figure 4-3 Input Connection Diagram

The sensor has 64 channels, and the combination of input signals through 6 IO ports is switched to the channel of the specified number. The detection range of the channel needs to be set in advance through the configuration software. The external device can select and switch the area through the input signal, refer to Table 2 (input normally open). O: Input has signal; X: Input has no signal or open circuit.

channel number	In6	In5	In4	In3	In2	In1
0	X	X	X	X	X	X
1	X	X	X	X	X	○
2	X	X	X	X	○	X
3	X	X	X	X	○	○
4	X	X	X	○	X	X
5	X	X	X	○	X	○
6	X	X	X	○	○	X
7	X	X	X	○	○	○
8	X	X	○	X	X	X
9	X	X	○	X	X	○
10	X	X	○	X	○	X
11	X	X	○	X	○	○
12	X	X	○	○	X	X
13	X	X	○	○	X	○
14	X	X	○	○	○	X
15	X	X	○	○	○	○
16	X	○	X	X	X	X
17	X	○	X	X	X	○
18	X	○	X	X	○	X
19	X	○	X	X	○	○
20	X	○	X	○	X	X
21	X	○	X	○	X	○
22	X	○	X	○	○	X
23	X	○	X	○	○	○
24	X	○	○	X	X	X
25	X	○	○	X	X	○
26	X	○	○	X	○	X
27	X	○	○	X	○	○
28	X	○	○	○	X	X
29	X	○	○	○	X	○
30	X	○	○	○	○	X
31	X	○	○	○	○	○
32	○	X	X	X	X	X
33	○	X	X	X	X	○
34	○	X	X	X	○	X
35	○	X	X	X	○	○
36	○	X	X	○	X	X
37	○	X	X	○	X	○

38	○	X	X	○	○	X
39	○	X	X	○	○	○
40	○	X	○	X	X	X
41	○	X	○	X	X	○
42	○	X	○	X	○	X
43	○	X	○	X	○	○
44	○	X	○	○	X	X
45	○	X	○	○	X	○
46	○	X	○	○	○	X
47	○	X	○	○	○	○
48	○	○	X	X	X	X
49	○	○	X	X	X	○
50	○	○	X	X	○	X
51	○	○	X	X	○	○
52	○	○	X	○	X	X
53	○	○	X	○	X	○
54	○	○	X	○	○	X
55	○	○	X	○	○	○
56	○	○	○	X	X	X
57	○	○	○	X	X	○
58	○	○	○	X	○	X
59	○	○	○	X	○	○
60	○	○	○	○	X	X
61	○	○	○	○	X	○
62	○	○	○	○	○	X
63	○	○	○	○	○	○

Reminder: If you do not need to use all 64 channels, you can determine the input signal to be connected according to the required number of channels;

Output signal connection

Output signal use function:

OUT1 (attention area): used for remote obstacle warning and deceleration;

OUT2 (early warning area): used for normal obstacle detection and normal stop;

OUT3

(alarm area): used for near-end emergency stop;

The output is an open collector (NPN) signal, as shown in Figure 4-4, using optocoupler isolation output, the voltage is 0V- when the output has a signal, and the maximum load capacity of the output port is 100mA

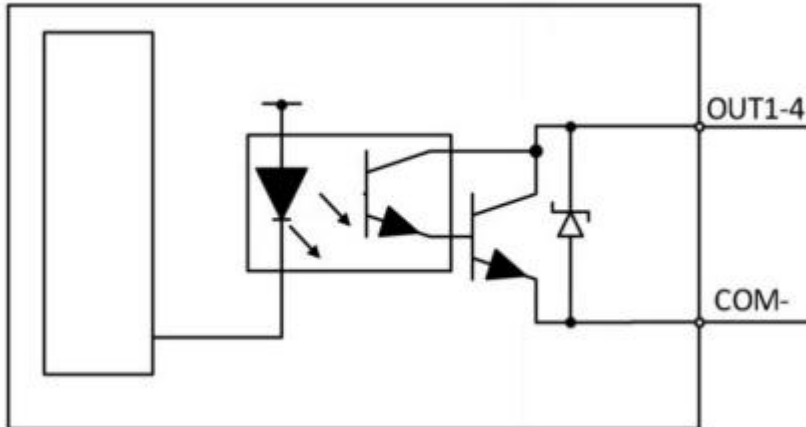

Figure 4-4 Output Schematic

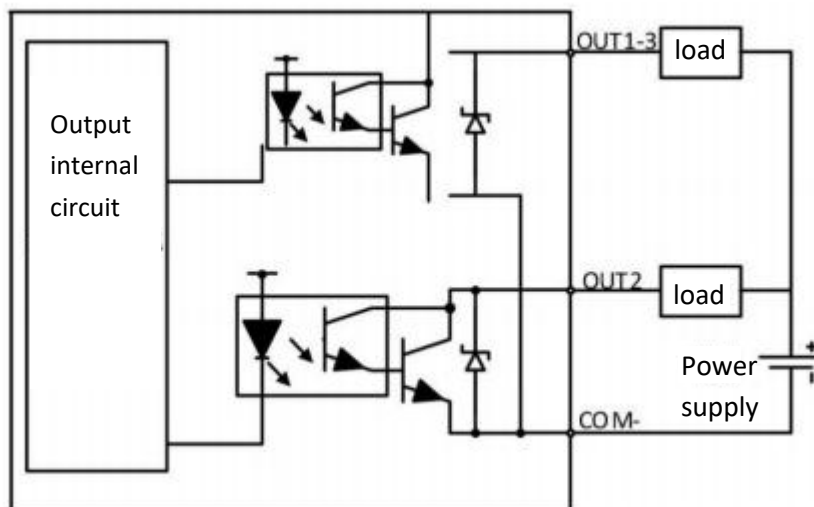

Figure 4-5 Output Connection Diagram

The sensor output ports correspond to the graphics drawn in the configuration software, as shown in Figure 4-6

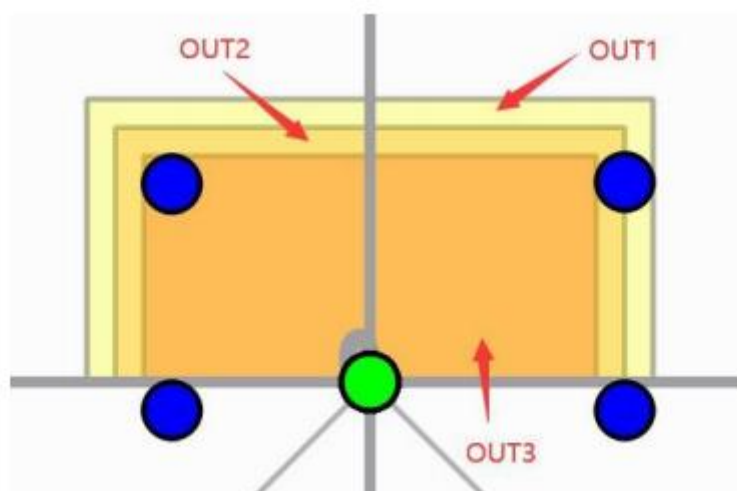

Figure 4-6 Drawing the relationship between the image and the output

Note: When the corresponding output has a drawing graph, there will be a detection output;

## 4.4 Connection example

According to the wiring when all 64 channels are fully used and all outputs are fully used, Figure 4-7 shows that the host computer passes.

NPN transistor output signal and PLC receive signal.

X0-X3 are the signal input ports of PLC;

Y0-Y5 are the signal output ports of PLC;

IN1-IN6 input current is greater than 5mA;

Out1-Out4 output current is less than 100mA;



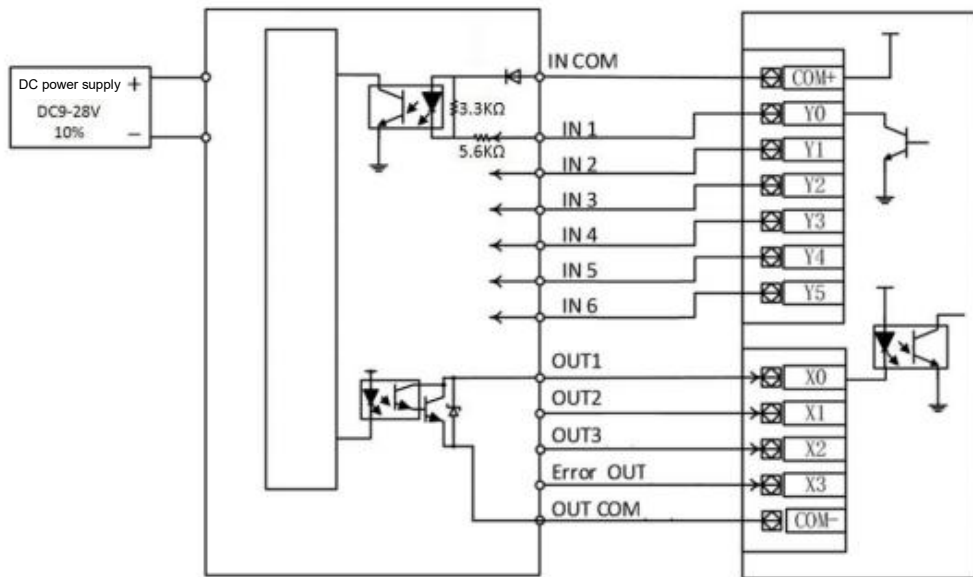

Figure 4-7 Example of connection between I3 and PLC

Note: The input and output ports cannot be short-circuited or connected to a load exceeding the specified current, otherwise the sensor will be damaged.

## 5 Software Operation Method

### 5.1 Main interface - device settings

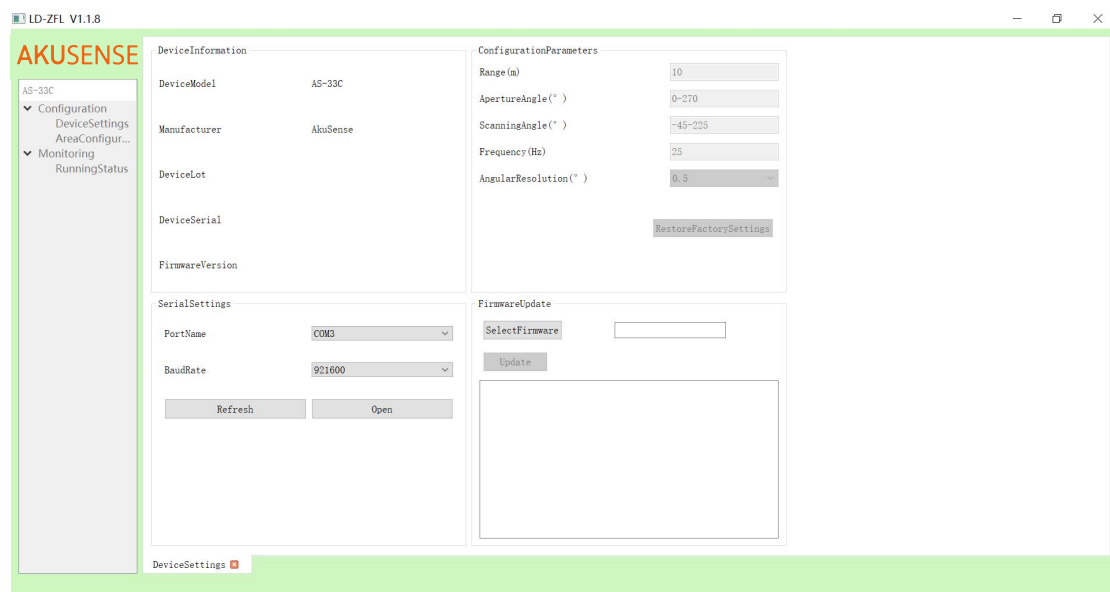

Figure 5-1 Main interface of the software - device configuration

View device information: Right-click My Computer->Management->Device Management->Ports (COM and LPT)->Find the corresponding serial port, as shown in Figure 5-2, the serial port No. is COM4

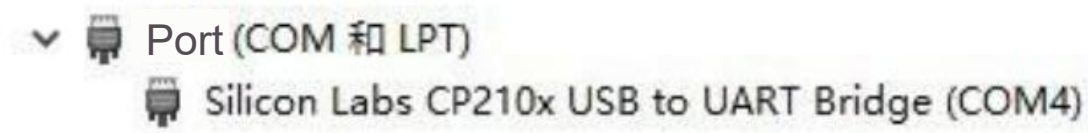

Figure 5-2 View COM port

Serial port settings: Select the corresponding COM serial port number COM4 on the main interface ->click to open . If the serial port selection is wrong, the following prompt box will pop up (Figure 5-3):

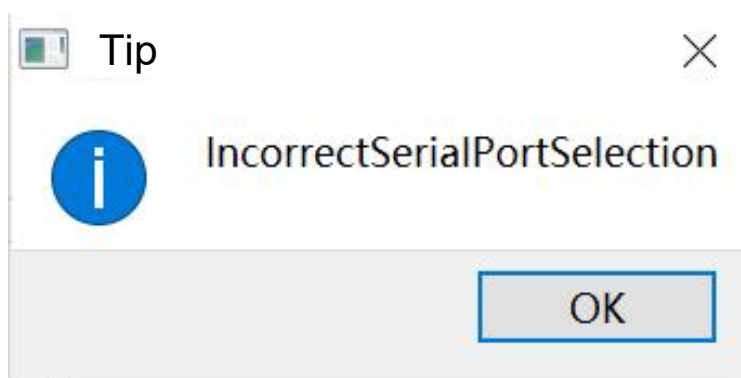

Figure 5-3 Serial port error prompt

Click OK, and re-select the correct serial port to open it. When the Lidar is connected, the software will read the area configuration information of the 64 area groups of the Lidar, and the reading progress will appear below, as shown in the figure 5-4. When the progress bar reaches 100%, it means that the software has successfully read the internal information of the Lidar, and will unlock the area monitoring configuration and running status interface.

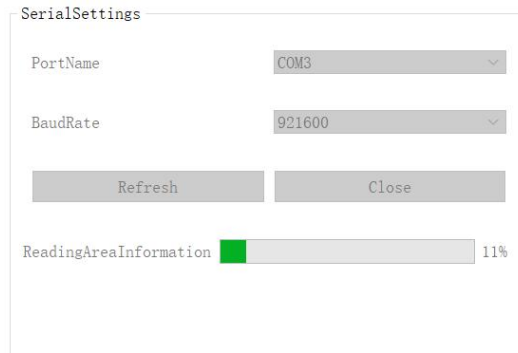

Figure 5-4 Open the serial port

After the Lidar is successfully connected, the product information bar will display the information read from the inside of the Lidar, including product model, manufacturer, serial number, batch number and firmware version. As shown in Figure 5-5.

Figure 5-4 Open the serial port After the Lidar is successfully connected, the product information bar will display the information read from the inside of the Lidar, including product model, manufacturer, serial number, batch number and firmware version. As shown in Figure 5-5.

DeviceInformation	
DeviceModel	AS-33C
Manufacturer	AkuSense
DeviceLot	C20220701
DeviceSerial	C22270054
FirmwareVersion	V1.2.0

Figure 5-5 Product Information

Running configuration parameters:

The running configuration parameters column displays the performance parameters of the Lidar, as shown in Figure 5-6, among which the Restore Factory Settings button is used to restore the factory default configuration with one key.

ConfigurationParameters

Range (m)	10
ApertureAngle(° )	0-270
ScanningAngle(° )	-45-225
Frequency (Hz)	25
AngularResolution(° )	0.5

RestoreFactorySettings

Figure 5-6 Run Configuration Parameters

Firmware update:

The firmware update column is used to update the firmware of the Lidar, as shown in Figure 5-7. The new firmware is provided by the manufacturer.

FirmwareUpdate

SelectFirmware EN/AS-33C-V1.1.3.bin

Update

```
Entering bootloader mode
Current bootloader mode
Starting Firmware Update
CurrentProgress: 0%
CurrentProgress: 1%
CurrentProgress: 2%
CurrentProgress: 4%
CurrentProgress: 5%
CurrentProgress: 6%
CurrentProgress: 8%
CurrentProgress: 9%
CurrentProgress: 11%
CurrentProgress: 12%
```

Figure 5-7 Firmware Update

## 5.2 Regional Monitoring Configuration

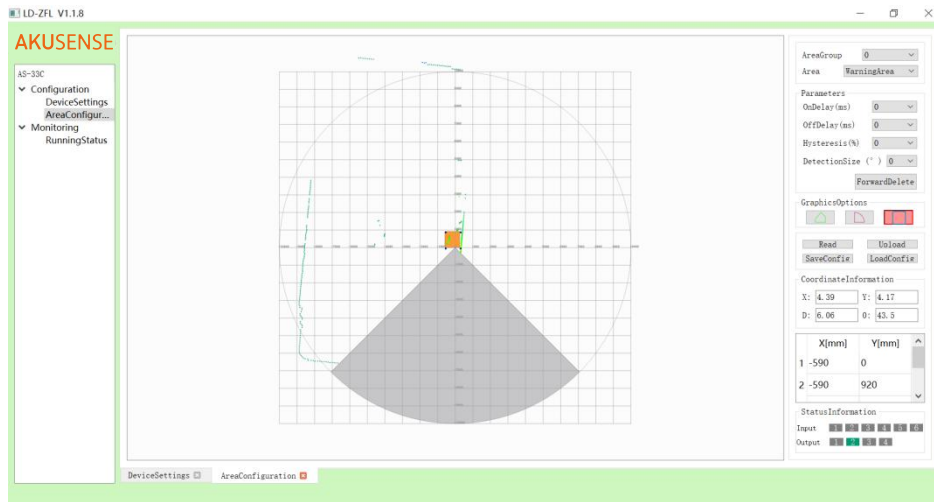

Figure 5-8 Area monitoring configuration interface

1. Area group: There are 64 areas numbered 0-63, and each area group has three area information
2. Area: The area is divided into three areas: attention area, early warning area, and alarm area.
3. Graphics options: Polygon, Sector and Rectangle.
4. Read button: read current area group information from Lidar; upload button: upload 64 area group information, upload progress bar will appear below.
5. Coordinate information: current mouse coordinates, distance, angle information.
6. Drawing coordinate point position information table.
7. Status information: The output shows the status of the input and output terminals.

### Instructions:

1. In the coordinate information table, double-click the table, modify the coordinate point, and press Enter to confirm, the corresponding point and graph of the drawing interface will be changed accordingly.
2. Click to select the drawing scene, and the mouse wheel can zoom the size of the graph. After the graph is enlarged, you can use the up, down, left, right, and arrow keys to move the view of the graph.

3. After selecting the area group, area and editing area, you can draw graphics by moving the points in the drawing scene. 4. Output terminal: Display the output status.

1. Attention area 2. Early warning area 3. Alarm area

4. Error status information; if there is an object entering the corresponding area in the edited graph, the corresponding area of the output terminal will display green, otherwise it will display gray; if the Lidar has error information, then 4 will turn green and gray if there are no errors.

5. Input terminal: Display the control state of the input.

## 5.3 Operating status

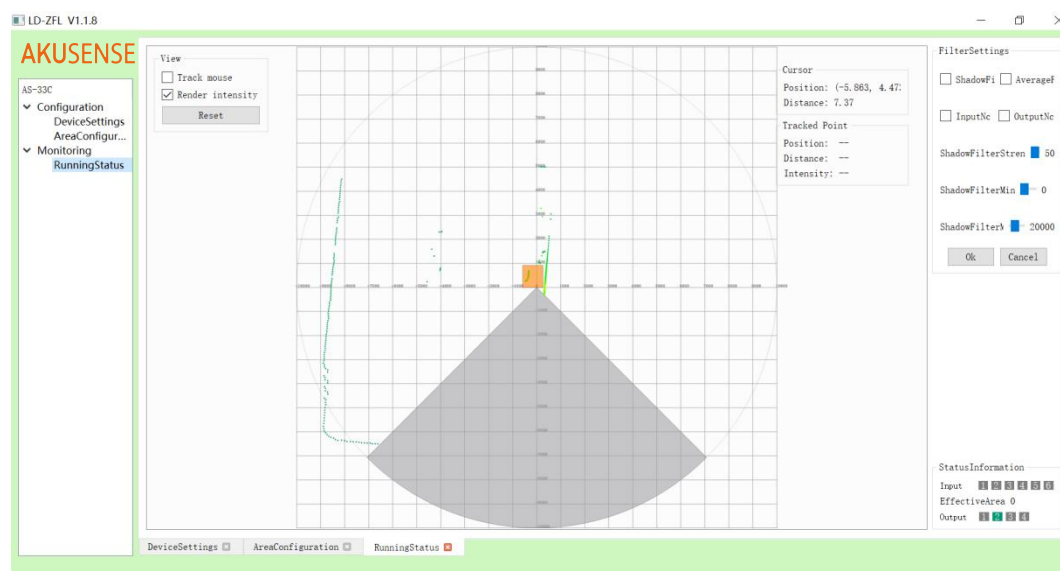

Figure 5-9 Running state interface

1. If track mouse is checked, the mouse is on the interface. If there is a point between the mouse and the origin, the point will turn red, and the coordinates, distance and intensity will be displayed.

2. Render intensity option, different intensities are marked with different colors, the redder the color, the greater the intensity, and the bluer the color, the lower the intensity.

3. Filter settings: You can set the enable, intensity and range of the trailing filter; you can set the enable of the average filter. When the average filter is enabled, the Lidar sampling rate is increased from the original 18 KHz to 54 KHz, and 3 averages are performed.

4. The input and output can be set as normally open and normally closed.

5. Status information: The output shows the status of the input and output terminals.

**Instructions:**

1. After the parameter is changed, click OK to permanently save it in the Lidar, and click cancel to restore the original setting.
2. Output terminal: Display the output status. 1. Attention area 2. Early warning area 3. Alarm area 4. Error status information; if there is an object entering the corresponding area in the edited graph, the corresponding area of the output terminal will display green, otherwise it will display gray; if the Lidar has error information, then 4 will turn green and gray if there are no errors.
3. Input terminal: Display the control state of the input.
4. Click to select the Point Cloud view, you can zoom in and out with the middle mouse button. After the graph is enlarged, you can adjust the view angle of the graph by using the up, down, left, and right arrow keys.

# 6 Specification

