

Compact Cylinder Series CQS

ø12, ø16, ø20, ø25

Ideal for machine designs with small space requirements

The "D-A9□" and "D-M9□" auto switches will not protrude from switch mounting groove.

Square body shape gives you flexibility for machine design

Auto switch mounting allows for flexible designing requirements

3 faces on ø12 & ø16, and all 4 faces including port side on ø20, ø25.

2 way basic mounting: Through-hole or both ends tapped

Basic mounting is 2 way. You can choose either through-hole or both ends tapped mounting.

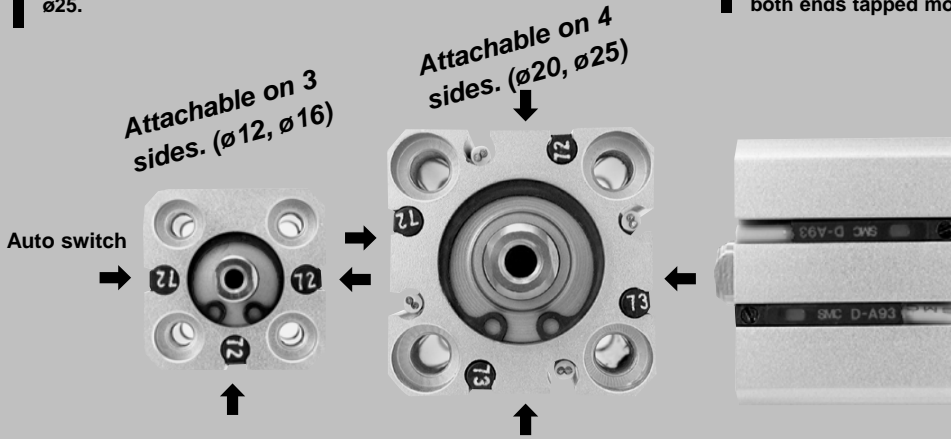

**Non-rotating piston rod model
Superior non-rotating accuracy**

Hexagonal cross sectional shape piston rod for high non-rotation accuracy.

ø12, ø16 — ±1°
ø20, ø25 — ±0.7°

Variations

	Basic model	Variations (Standard)	Applicable auto switch	Bore size (mm)	Stroke (mm)	Page
Basic	Series CQS	Single Rod	Reed switch D-A90, A90V D-A93, A93V D-A96, A96V	12, 16 20, 25	Standard stroke ø12 } 5, 10, 15, 20 ø16 } 25, 30 ø20 } 5, 10, 15, 20 ø25 } 25, 30, 35, 40 45, 50	1-372
	Series CQSW	Double Rod				
Non-rotating Rod	Series CQS	Return/Extend	Solid state switch D-M9N, M9NV D-M9P, M9PV D-M9B, M9BV D-M9NW, M9NWW D-M9PW, M9PWW D-M9BW, M9BWW	12, 16 20, 25	5, 10	1-386
	Series CQSK	Single Rod				
Anti-lateral Load	Series CQS□S	Single Rod			5, 10, 15, 20 25, 30 ø20 } 5, 10, 15, 20 ø25 } 25, 30, 35, 40 45, 50	1-400

* Non-rotating rod/Double acting double rod can be made.

*1 Standard equipment on long stroke model/anti-lateral load model
*2 Available only for standard stroke model

- Built-in magnet
- Rod end male thread
- Rubber bumper
- Foot/Flange mounting
- Double clevis mounting
- Clean Series

Compact Cylinder/Standard: Double Acting Single Rod

Series CQS

ø12, ø16, ø20, ø25

How to Order

Standard

CQS B 20 30 D

With auto switch

CDQS B 20 30 D A90 S

With auto switch (Built-in magnet)

Mounting style

B	Through-hole/Both ends tapped (Standard)
L	Foot
F	Front flange
G	Rear flange
D	Double clevis

Bore size

12	12mm
16	16mm
20	20mm
25	25mm

* In case of long stroke, use either ends tapped mounting or bracket mounting.
** Mounting brackets are shipped not assembled with the cylinder.

Number of auto switches

—	2
S	1
n	n

Auto switch

—	Without auto switch (Built-in magnet)
---	---------------------------------------

Refer to the table below for auto switch symbol.

Option

<Standard stroke>		<Long stroke>	
—	No option	C	Rubber bumper (Standard equipment for long stroke model)
C	Rubber bumper	CM	Rubber bumper & Rod end male thread
M	Rod end male thread		

* "C" and "M" can be combined.

Action

D	Double acting
---	---------------

Cylinder stroke (mm)

Bore size (mm)	Standard stroke (mm)	Long stroke (mm)
12, 16	5, 10, 15, 20, 25, 30	35, 40, 45, 50, 75, 100
20	5, 10, 15, 20, 25, 30, 35, 40, 45, 50	75, 100, 125, 150, 175, 200
25		75, 100, 125, 150, 175, 200, 250, 300



Refer to p.1-373 for intermediate strokes.

Mounting Bracket Part No.

Bore size (mm)	Foot ⁽¹⁾	Flange	Double clevis
12	CQS-L012	CQS-F012	CQS-D012
16	CQS-L016	CQS-F016	CQS-D016
20	CQS-L020	CQS-F020	CQS-D020
25	CQS-L025	CQS-F025	CQS-D025



Note 1) 2 pieces per cylinder should be ordered.
Note 2) Each package contains the following parts.
Foot or Flange style : Body mounting bolt
Double clevis style : Clevis pin, snap ring retainer, body mounting bolt.

Applicable Auto Switches

Style	Special function	Electrical entry	Indicator	Wiring (Output)	Load voltage			Auto switch model		Lead wire(m) [*]			Applicable load	
					DC	AC		Perpendicular	In-line	0.5 (—)	3 (L)	5 (Z)		
						5V	100V or less							
Reed switch	—	Grommet	No	2 wire	24V	5V	100V or less	A90V	A90	●	●	—	IC	Relay PLC
						12V	100V	A93V	A93	●	●	—		
					Yes	3 wire (Equiv. NPN)	—	5V	—	A96V	A96	●	●	—
Solid state switch	—	Grommet	Yes	3 wire (NPN)	24V	12V	—	M9NV	M9N	●	●	—	—	Relay PLC
				3 wire (PNP)				M9PV	M9P	●	●	—		
				2 wire				M9BV	M9B	●	●	—		
				3 wire (NPN)				M9NWW	M9NWW	●	●	○		
				3 wire (PNP)				M9PWV	M9PW	●	●	○		
				2 wire				M9BWW	M9BW	●	●	○		
				Water resistant (2 colour)				—	M9BA	—	●	○		

* Lead wire length 0.5m — (Example) A93
3m L (Example) A93L
5m Z (Example) M9NWW
* ○ : Manufactured upon receipt of order.

Compact Cylinder/Standard: Double Acting Single Rod **Series CQS**



Specifications

Style	Pneumatic (Non-lube)
Action	Double acting, single rod
Fluid	Air
Proof pressure	1.5MPa
Max. operating pressure	1.0MPa
Ambient & fluid temperature	Without auto switch -10°C to 70°C (No freezing) With auto switch -10°C to 60°C (No freezing)
Rubber bumper	Standard stroke: None Long stroke: Standard equipment
Rod end thread	Female
Rod end thread tolerance	JIS class 2
Stroke length tolerance	Standard stroke: $^{+1.0}_0$ Long stroke: $^{+1.4}_0$
Basic mounting	Through-hole/Both ends tapped
Operating piston speed	50 to 500 mm/s

Minimum Strokes for Auto Switch Mounting

Unit: mm

No. of auto switches	D-A9□, D-M9□WV	D-A9□V	D-M9N	D-M9 ^B _P , D-M9□W	D-M9□V	D-M9BA
2	10	10	15*	20*	5	25*
1	10*	5	15*	20*	5	25*

* Consult SMC for shorter stroke lengths than indicated in the table.

JIS symbol

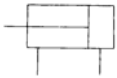

Theoretical Force

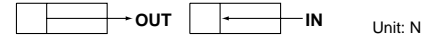

Unit: N

Bore size (mm)	Rod diameter (mm)	Operation	Piston area (mm ²)	Operating pressure (MPa)		
				0.3	0.5	0.7
12	6	IN	84.8	25	42	59
		OUT	113	34	57	79
16	8	IN	151	45	75	106
		OUT	201	60	101	141
20	10	IN	236	71	118	165
		OUT	314	94	157	220
25	12	IN	378	113	189	264
		OUT	491	147	245	344

Allowable Kinetic Energy

Unit: J

Bore size (mm)	12	16	20	25
Standard	0.022	0.038	0.055	0.09
With rubber bumper	0.043	0.075	0.11	0.18

Minimum Operating Pressure

Unit: MPa

Bore size (mm)	12	16	20	25
Min. operating pressure (MPa)	0.07	0.07	0.05	0.05

Option

Option	Availability
Rod end thread	Available for all standard models
Rubber bumper *	of double acting single rod.

* Rubber bumper is a standard equipment for long stroke models.

Intermediate Strokes

Method		Spacer is attached on standard stroke body.		Exclusive body (-XB10)	
Model no.		Refer to "How to Order" for standard model no.		Specify "-XB10" at the end of standard model number.	
Standard stroke	Method	Intermediate strokes at 1mm intervals are available by using spacers with standard stroke cylinders.		Intermediate strokes at 1mm intervals are available by using exclusive body with required stroke.	
	Stroke range	Bore size	Stroke range	Bore size	Stroke range
		12, 16	1 to 30	12, 16	6 to 30
20, 25	1 to 50	20, 25	6 to 50		
Long stroke	Method	Intermediate strokes at 5mm intervals are available by using spacers with standard stroke cylinders.		Intermediate strokes at 1mm intervals are available by using exclusive body with required stroke.	
	Stroke range	Bore size	Stroke range	Bore size	Stroke range
		12, 16	35 to 100	12, 16	31 to 100
		20	55 to 200	20	31 to 200
25	55 to 300	25	31 to 300		
Example		Model no. : CQSB25-47D CQSB25-50D with 3mm width spacer inside. B dimension is 72.5mm.		Model no. : CQSB25-47D -XB10 Makes 47stroke tube. B dimension is 69.5mm.	

Series CQS

Weight/Without Auto Switch

Unit: g

Bore (mm)	Stroke (mm)																	
	5	10	15	20	25	30	35	40	45	50	75	100	125	150	175	200	250	300
12	29	36	42	49	56	63	93	100	107	113	147	180	—	—	—	—	—	—
16	38	47	56	64	73	82	119	128	136	145	187	229	—	—	—	—	—	—
20	63	75	88	101	114	127	140	153	166	178	306	370	434	498	562	627	—	—
25	91	107	123	139	155	171	186	202	218	234	399	478	557	636	715	794	952	1110

Standard stroke model

Calculation Example) CQSD20-20DCM

- Cylinder weight: CQSB20-20D.....101g
- Option weight : Rod end male thread..... 10g
- : Rubber bumper.....2g
- : Double clevis..... 92g

Total 201g

Weight/With Auto Switch (Built-in magnet)

Unit: g

Bore (mm)	Stroke (mm)																	
	5	10	15	20	25	30	35	40	45	50	75	100	125	150	175	200	250	300
12	37	43	50	57	63	70	94	101	108	114	148	181	—	—	—	—	—	—
16	48	57	66	74	83	92	121	129	137	146	188	231	—	—	—	—	—	—
20	93	106	119	132	144	157	170	182	195	208	311	375	439	503	567	632	—	—
25	134	150	166	182	197	213	229	245	261	277	406	485	564	643	721	800	958	1116

Option Weights

Unit: g

Bore size (mm)		12	16	20	25
Rod end thread	Male thread	1.5	3	6	12
	Nut	1	2	4	8
Rubber bumper (1)		0	1	-2	-3
Foot (including bolt)		55(53)	65(61)	159(153)	181(172)
Front flange (including bolt)		58(56)	70(66)	143(137)	180(171)
Rear flange (including bolt)		56	66	137	171
Double clevis (including pin, retainer, bolt)		34	40	92	127

() : Long stroke model

Note 1) Do not add value shown in the table above to long stroke models.

Copper Free

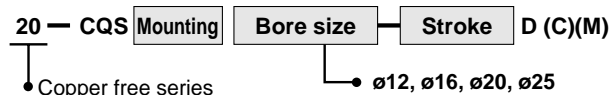

To eliminate influences of copper ions or halogen ions during CRT manufacturing processes, copper and fluorine materials are not used as component parts.

Specifications

Action	Double acting single rod
Cylinder bore size	$\phi 12, \phi 16, \phi 20, \phi 25$
Proof pressure	1.5MPa
Max. operating pressure	1.0MPa
Rubber bumper	Standard stroke: Without, Long stroke: With
Piston speed	50 to 500mm/s
Mounting	Through-hole, Both ends tapped

⚠ Precautions

⚠ Caution

Handling

- ① All loads to piston rod must be applied in axial direction only.
 - Unavoidable side loads to rod end must be less than the values in the graphs.
 - Cylinder installation requires accurate alignment.
 - Adoption of guide mechanism is strongly recommended for the case when CQS is used as stopper to prevent non-rotating piston rod from side loads.
- ② To secure a workpiece to the end of the piston rod, make sure to retract the piston rod entirely, and place a wrench on the portion of the rod that protrudes beyond the section. To tighten, take precautions to prevent the tightening torque from being applied to the non-rotating guide.

⚠ Caution

Snap Ring Installation/Removal

- ① For installation and removal, use an appropriate pair of pliers (tool for installing a C snap ring).
- ② Exercise caution even when using an appropriate pair of pliers (tool for installing a C snap ring), because of the possibility of the snap ring becoming detached from the tip of the pliers and flying away, which could injure humans or damage the peripheral equipment. After installing the snap ring, make sure that it is placed securely in the ring groove before supplying air.

Allowable Rod End Lateral Load



<Figure 1>Basic: Non-rotating rod/
Without auto switch

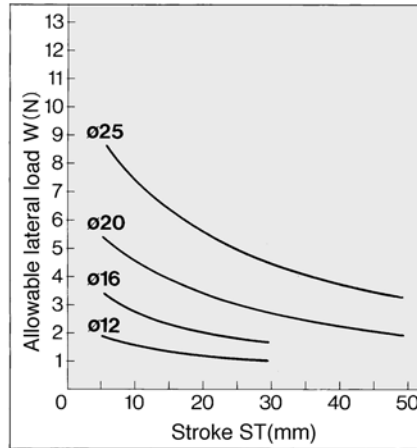

<Figure 2>Standard: Non-rotating rod/
Without auto switch

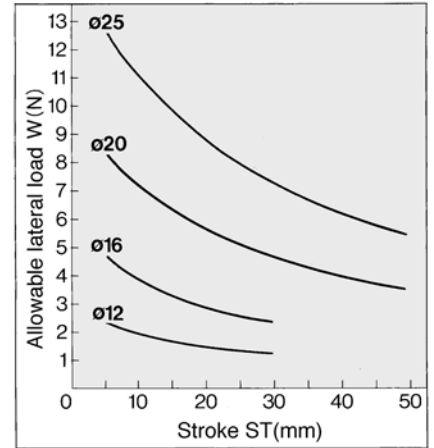

<Figure 3>Anti-lateral load/
Without auto switch

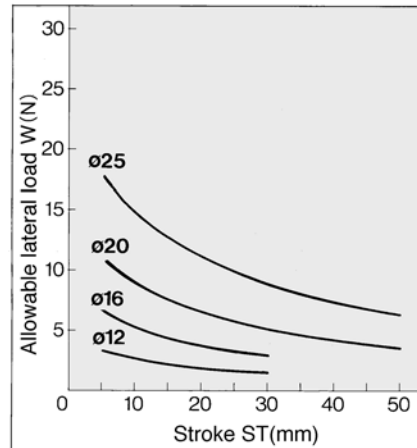

<Figure 4>Anti-lateral load/
Without auto switch

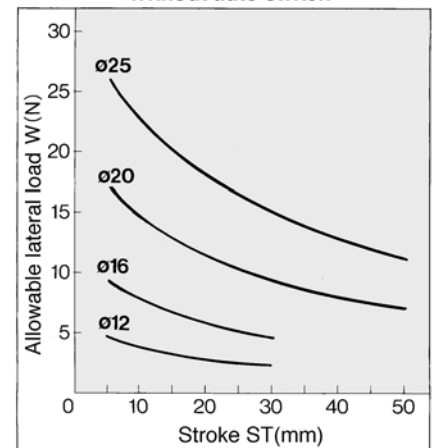

<Figure 5>Long stroke/
With & Without auto switch

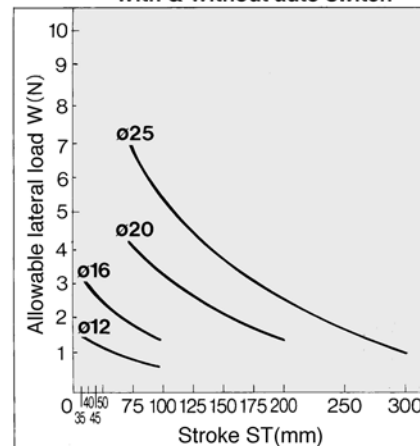

Note 1) Figure 1 to 5: Rod end female thread
 Note 2) Lateral load allowance varies depending upon rod end shape dimensions or load valve (distance to the centre of the gravity of load.) Consult SMC.

Series CQS

Construction

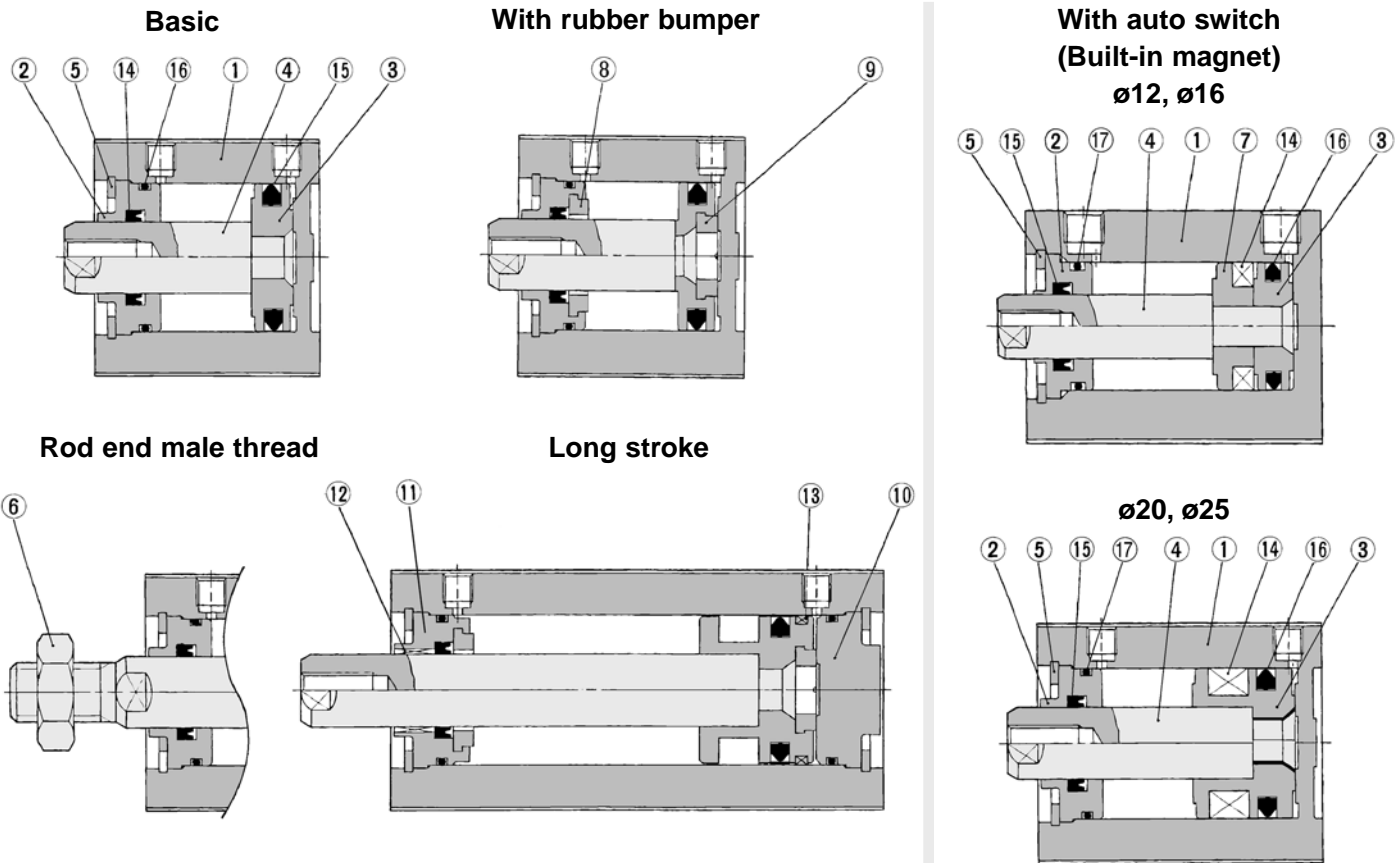

Component Parts

No.	Description	Material	Note
①	Cylinder tube	Aluminum alloy	Hard anodized
②	Collar	Aluminum bearing alloy	Anodized
③	Piston	Aluminum alloy	Chromated
④	Piston rod	Stainless steel	
⑤	Snap ring	Carbon tool steel	Phosphate coating
⑥	Rod end nut	Carbon steel	Nickel plated
⑦	Switch spacer	Aluminum alloy	Chromated
⑧	Bumper A	Urethane	
⑨	Bumper B	Urethane	
⑩	Head cover	Aluminum alloy	Anodized

Component Parts

No.	Description	Material	Note
⑪	Collar	Aluminum alloy	Anodized
⑫	Bushing	Oil impregnated sintered alloy	
⑬	Wearing	Resin	
⑭	Magnet	—	
⑮*	Rod seal	NBR	
⑯*	Piston seal	NBR	
⑰*	Tube gasket	NBR	

Replacement Parts: Seal Kits

Bore size (mm)	Kit No.	Contents
12	CQSB12-PS	Kits includes items ⑮, ⑯ and ⑰ from the table above.
16	CQSB16-PS	
20	CQSB20-PS	
25	CQSB25-PS	

* Seal kits consist of items ⑮, ⑯ and ⑰ contained in one kit, and can be ordered using the order number for each respective tube bore size.

Clean Series (Available only on standard stroke.)

□ — C(D)QSB Bore size Stroke D(M)

• SMC Clean Series

10	Relief style
11	Vacuum suction style

The rod portion of the actuator has a double seal construction, and a relief port is provided to discharge the exhaust air directly outside of the clean room. Thus, it can be used in a Class 100 clean room.

Specifications

Action	Double acting single rod
Bore size	ø12, ø16, ø20, ø25
Proof pressure	1.5MPa
Max. operating pressure	1.0MPa
Rubber bumper	None
Piping	Screw-in
Operating piston speed	50 to 500mm/s
Mounting	Through-hole/Both ends tapped
Auto switch	Attachable

Note) Contact SMC for further information.

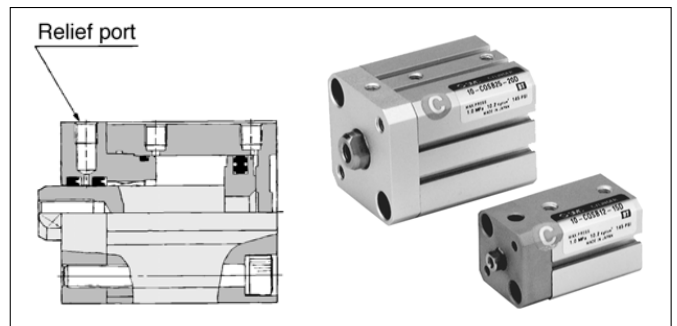

Compact Cylinder/Standard: Double Acting Single Rod **Series CQS**

Mounting Bolt for CQS

Special bolt for through-hole mounting is available as an option.

How to Order: Specify the required bolts

Example) Bolt M3 X 25ℓ 4pcs.
(Standard stroke)
Bolt M3 X 75ℓ 4pcs.
(Long stroke)

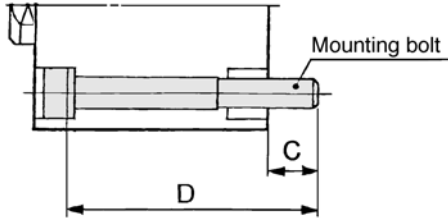

Note 1) The appropriate plain washer must be used for through-hole mounting.

Note 2) Contact SMC for details concerning the mounting bolts to be used with $\phi 12$ and $\phi 16$ that exceed 30mm strokes, or $\phi 20$ and $\phi 25$ that exceed 50mm strokes.

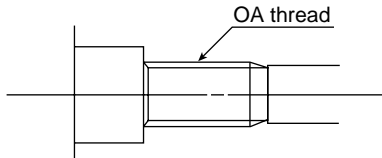

Model	C	D	Mounting bolt
CQSB12-5D	6.5	25	M3 X 25 ℓ
-10D		30	X 30 ℓ
-15D		35	X 35 ℓ
-20D		40	X 40 ℓ
-25D		45	X 45 ℓ
-30D		50	X 50 ℓ
-35DC	Secure the cylinder by using the OA screws that are provided with the cylinder tube.		
-40DC			
-45DC			
-50DC			
-75DC			
-100DC			
CQSB16-5D	6.5	25	M3 X 25 ℓ
-10D		30	X 30 ℓ
-15D		35	X 35 ℓ
-20D		40	X 40 ℓ
-25D		45	X 45 ℓ
-30D		50	X 50 ℓ
-35DC	Secure the cylinder by using the OA screws that are provided with the cylinder tube.		
-40DC			
-45DC			
-50DC			
-75DC			
-100DC			
CQSB20-5D	6.5	25	M5 X 25 ℓ
-10D		30	X 30 ℓ
-15D		35	X 35 ℓ
-20D		40	X 40 ℓ
-25D		45	X 45 ℓ
-30D		50	X 50 ℓ

Model	C	D	Mounting bolt
CQSB20-30D	6.5	50	M5 X 50 ℓ
-35D		55	X 55 ℓ
-40D		60	X 60 ℓ
-45D		65	X 65 ℓ
-50D		70	X 70 ℓ
-75DC	Secure the cylinder by using the OA screws that are provided with the cylinder tube.		
-100DC			
-125DC			
-150DC			
-175DC			
-200DC			
CQSB25-5D	8.5	30	M5 X 30 ℓ
-10D		35	X 35 ℓ
-15D		40	X 40 ℓ
-20D		45	X 45 ℓ
-25D		50	X 50 ℓ
-30D		55	X 55 ℓ
-35D		60	X 60 ℓ
-40D		65	X 65 ℓ
-45D		70	X 70 ℓ
-50D		75	X 75 ℓ
-75DC	Secure the cylinder by using the OA screws that are provided with the cylinder tube.		
-100DC			
-125DC			
-150DC			
-175DC			
-200DC			
-250DC			
-300DC			

Mounting Bolt for CDQS

Special bolt for through-hole mounting is available as option.

How to Order: Specify the required bolts

Example) Bolt M3 X 30ℓ 4pcs.
(Standard stroke)
Bolt M3 X 75ℓ 4pcs.
(Long stroke)

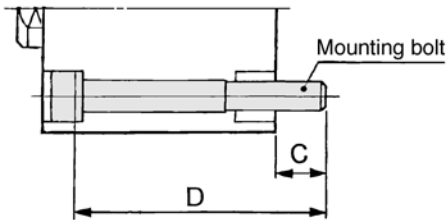

Note 1) The appropriate plain washer must be used for through-hole mounting.

Note 2) Contact SMC for details concerning the mounting bolts to be used with $\phi 12$ and $\phi 16$ that exceed 30mm strokes, or $\phi 20$ and $\phi 25$ that exceed 50mm strokes.

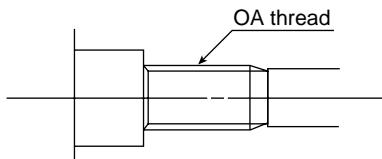

Model	C	D	Mounting bolt
CDQSB12-5D	6.5	30	M3 X 30 ℓ
-10D		35	X 35 ℓ
-15D		40	X 40 ℓ
-20D		45	X 45 ℓ
-25D		50	X 50 ℓ
-30D		55	X 55 ℓ
-35DC	Secure the cylinder by using the OA screws that are provided with the cylinder tube.		
-40DC			
-45DC			
-50DC			
-75DC			
-100DC			
CDQSB16-5D	6.5	30	M3 X 30 ℓ
-10D		35	X 35 ℓ
-15D		40	X 40 ℓ
-20D		45	X 45 ℓ
-25D		50	X 50 ℓ
-30D		55	X 55 ℓ
-35DC	Secure the cylinder by using the OA screws that are provided with the cylinder tube.		
-40DC			
-45DC			
-50DC			
-75DC			
-100DC			
CDQSB20-5D	6.5	35	M5 X 35 ℓ
-10D		40	X 40 ℓ
-15D		45	X 45 ℓ
-20D		50	X 50 ℓ
-25D		55	X 55 ℓ
-30D		60	X 60 ℓ

Model	C	D	Mounting bolt
CDQSB20-30D	6.5	60	M5 X 60 ℓ
-35D		65	X 65 ℓ
-40D		70	X 70 ℓ
-45D		75	X 75 ℓ
-50D		80	X 80 ℓ
-75DC	Secure the cylinder by using the OA screws that are provided with the cylinder tube.		
-100DC			
-125DC			
-150DC			
-175DC			
-200DC			
CDQSB25-5D	8.5	40	M5 X 40 ℓ
-10D		45	X 45 ℓ
-15D		50	X 50 ℓ
-20D		55	X 55 ℓ
-25D		60	X 60 ℓ
-30D		65	X 65 ℓ
-35D		70	X 70 ℓ
-40D		75	X 75 ℓ
-45D		80	X 80 ℓ
-50D		85	X 85 ℓ
-75DC	Secure the cylinder by using the OA screws that are provided with the cylinder tube.		
-100DC			
-125DC			
-150DC			
-175DC			
-200DC			
-250DC			
-300DC			

Accessory Bracket

Since the attached bracket of CQS is same as CQ2 series, please refer to P.1-442

- Single knuckle joint
- Double knuckle joint
- Pin for knuckle
- Rod end nut

Series CQS

Dimensions/ø12 to ø25

*Refer to p.1-408 for mounting position and height of auto switch.

Basic (Through-hole/Both ends tapped)/CQSB, CDQSB

ø12

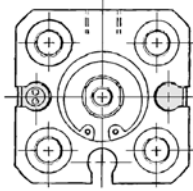

ø16

2 X 4-øOB
counter bore depth RB

H thread effective depth C

2 X 4-øOA effective depth RA ^{Note)}

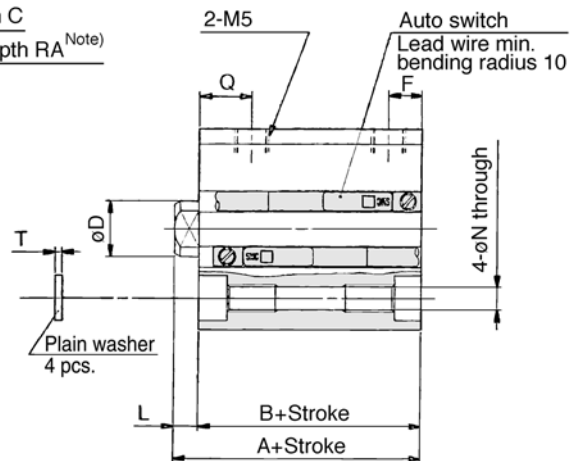
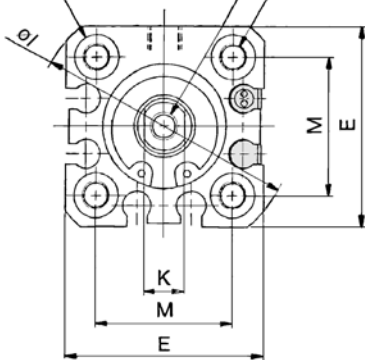

ø20,

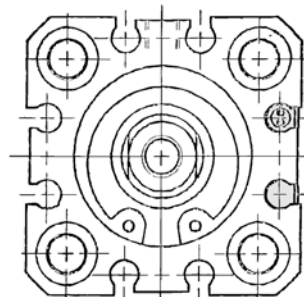

Rod end male thread

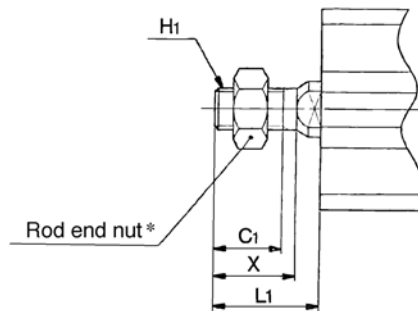

Rod end male thread ("L" is the only dimension that changes between standard stroke and long stroke.)

Bore (mm)	Standard stroke	Long stroke	C ₁	H ₁	X
	L ₁	L ₁			
12	14	24	9	M5	10.5
16	15.5	25.5	10	M6	12
20	18.5	28.5	12	M8	14
25	22.5	32.5	15	M10 X 1.25	17.5



* Length with intermediate stroke

(1) Spacer ...The dimensions will be identical to those of the nearest long stroke. Those that exceed the standard stroke will have the long stroke dimensions.

(2) Exclusive body (-X10)...Add stroke. Stroke lengths that exceed standard are long stroke dimensions.

Basic

("A", "B", "F" and "L" are different between standard stroke and long stroke.)

Bore (mm)	Standard stroke (mm)	Standard stroke								Long stroke (mm)	Long stroke																	
		Without auto switch				With auto switch					With/Without auto switch				C	D	E	H	I	K	M	N	OA	OB	Q	RA	RB	T
		A	B	F	L	A	B	F	L		A	B	F	L														
12	5 to 30	20.5	17	5	3.5	25.5	22	5	3.5	35 to 100	45.5	32	7.5	13.5	6	6	25	M3	32	5	15.5	3.5	M4	6.5	7.5	7	4	0.5
16	5 to 30	20.5	17	5	3.5	25.5	22	5	3.5	35 to 100	45.5	32	7.5	13.5	8	8	29	M4	38	6	20	3.5	M4	6.5	7.5	7	4	0.5
20	5 to 50	24	19.5	5.5	4.5	34	29.5	5.5	4.5	75 to 200	55.5	41	9	14.5	7	10	36	M5	47	8	25.5	5.4	M6	9	9	10	7	1
25	5 to 50	27.5	22.5	5.5	5	37.5	32.5	5.5	5	75 to 300	59	44	11	15	12	12	40	M6	52	10	28	5.4	M6	9	11	10	7	1

Note 1) For the following bore/stroke sizes through-hole is threaded over the entire length: Basic style ø12 and ø16; 5 stroke, ø20; 5 to 15 stroke, ø25; 5 to 10 stroke, ø20 with auto switch built-in magnet; 5 stroke.

Note 2) Rubber bumper style has the same dimensions as those indicated above.

* Refer to p.1-442 for details of the rod end nut and mounting brackets.

Compact Cylinder/Standard: Double Acting Single Rod **Series CQS**

Foot/CQSL, CDQSL

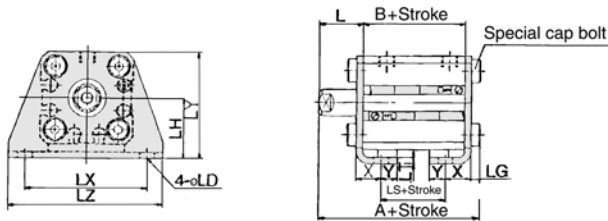

Rod end male thread

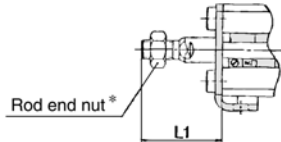

Front flange/CQSF, CDQSF

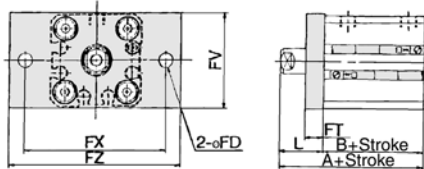

Rod end male thread

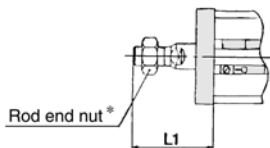

Rear flange/CQSG, CDQSG

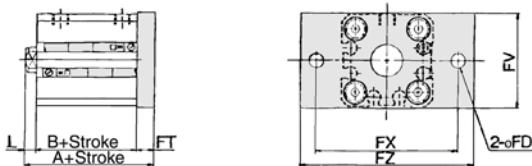

Rod end male thread

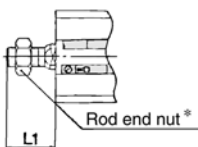

Double clevis/CQSD, CDQSD

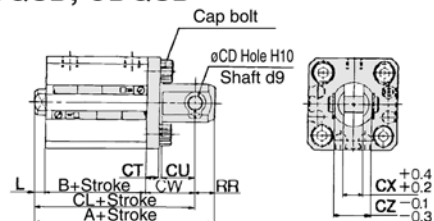

Rod end male thread

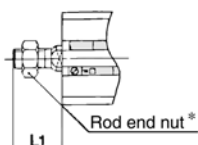

Foot

(All dimensions are common between standard stroke and long stroke except "A", "B", and "LS".)

Bore (mm)	Standard stroke (mm)	Standard stroke (mm)						Long stroke (mm)	Long stroke		
		Without auto switch			With auto switch				Without/with auto switch		
		A	B	LS	A	B	LS		A	B	LS
12	5 to 30	35.3	17	5	40.3	22	10	35 to 100	50.3	32	20
16	5 to 30	35.3	17	5	40.3	22	10	35 to 100	50.3	32	20
20	5 to 50	41.2	19.5	7.5	51.2	29.5	17.5	75 to 200	62.7	41	29
25	5 to 50	44.7	22.5	7.5	54.7	32.5	17.5	75 to 300	66.2	44	29

Bore (mm)	L	L1	LD	LG	LH	LT	LX	LY	LZ	X	Y
12	13.5	24	4.5	2.8	17	2	34	29.5	44	8	4.5
16	13.5	25.5	4.5	2.8	19	2	38	33.5	48	8	5
20	14.5	28.5	6.6	4	24	3.2	48	42	62	9.2	5.8
25	15	32.5	6.6	4	26	3.2	52	46	66	10.7	5.8

Front flange

(All dimensions are common between standard stroke and long stroke except "A" and "B".)

Bore (mm)	Standard stroke (mm)	Standard stroke (mm)				Long stroke (mm)	Long stroke	
		Without auto switch		With auto switch			Without/with auto switch	
		A	B	A	B		A	B
12	5 to 30	30.5	17	35.5	22	35 to 100	45.5	32
16	5 to 30	30.5	17	35.5	22	35 to 100	45.5	32
20	5 to 50	34	19.5	44	29.5	75 to 200	55.5	41
25	5 to 50	37.5	22.5	47.5	32.5	75 to 300	59	44

Bore (mm)	FD	FT	FV	FX	FZ	L	L1
12	4.5	5.5	25	45	55	13.5	24
16	4.5	5.5	30	45	55	13.5	25.5
20	6.6	8	39	48	60	14.5	28.5
25	6.6	8	42	52	64	15	32.5

Rear flange

(All dimensions are common between standard stroke and long stroke except "A", "B", "L" and "L1".)

Bore (mm)	Standard stroke (mm)	Standard stroke (mm)								Long stroke (mm)	Long stroke			
		Without auto switch				With auto switch					Without/with auto switch			
		A	B	L	L1	A	B	L	L1		A	B	L	L1
12	5 to 30	26	17	3.5	14	31	22	3.5	14	35 to 100	51	32	13.5	24
16	5 to 30	26	17	3.5	15.5	31	22	3.5	15.5	35 to 100	51	32	13.5	25.5
20	5 to 50	32	19.5	4.5	18.5	42	29.5	4.5	18.5	75 to 200	63.5	41	14.5	28.5
25	5 to 50	35.5	22.5	5	22.5	45.5	32.5	5	22.5	75 to 300	67	44	15	32.5

Bore (mm)	FD	FT	FV	FX	FZ
12	4.5	5.5	25	45	55
16	4.5	5.5	30	45	55
20	6.6	8	39	48	60
25	6.6	8	42	52	64

Double clevis

(All dimensions are common between standard stroke and long stroke except "A", "B", "C", "L" and "L1".)

Bore (mm)	Standard stroke (mm)	Standard stroke (mm)										Long stroke (mm)	Long stroke				
		Without auto switch					With auto switch						Without/with auto switch				
		A	B	CL	L	L1	A	B	CL	L	L1		A	B	CL	L	L1
12	5 to 30	40.5	17	34.5	3.5	14	45.5	22	39.5	3.5	14	35 to 100	65.5	32	59.5	13.5	24
16	5 to 30	41.5	17	35.5	3.5	15.5	46.5	22	40.5	3.5	15.5	35 to 100	66.5	32	60.5	13.5	25.5
20	5 to 50	51	19.5	42	4.5	18.5	61	29.5	52	4.5	18.5	75 to 200	82.5	41	73.5	14.5	28.5
25	5 to 50	57.5	22.5	47.5	5	22.5	67.5	32.5	57.5	5	22.5	75 to 300	89	44	79	15	32.5

Bore (mm)	CD	CT	CU	CW	CX	CZ	RR
12	5	4	7	14	5	10	6
16	5	4	10	15	6.5	12	6
20	8	5	12	18	8	16	9
25	10	5	14	20	10	20	10

* Refer to P.1-442 for detail of the rod end nut and mounting brackets.

Compact Cylinder/Standard: Double Acting Double Rod

Series CQSW

ø12, ø16, ø20, ø25

How to Order

Standard CQSW B 20 30 D C

With auto switch CDQSW B 20 30 D C A90 S

With auto switch (Built-in magnet)

Mounting style

B	Through-hole/Both ends tapped
L	Foot
F	Flange

Bore size

12	12mm
16	16mm
20	20mm
25	25mm

Cylinder stroke (mm)

Standard stroke

Bore (mm)	Standard stroke (mm)
12, 16	5, 10, 15, 20, 25, 30
20, 25	5, 10, 15, 20, 25, 30, 35, 40, 45, 50

Number of auto switches

—	2
S	1
n	n

Auto switch

—	Without auto switch (Built-in magnet)
---	---------------------------------------

* Refer to table below for auto switch no.

Option

—	No option
C	Rubber bumper
M	Rod end male thread

* "C" and "M" can be combined.

Action

D	Double acting
----------	---------------

Mounting Bracket Part No.

Bore size (mm)	Foot ⁽¹⁾	Flange
12	CQS-L012	CQS-F012
16	CQS-L016	CQS-F016
20	CQS-L020	CQS-F020
25	CQS-L025	CQS-F025



Note 1) 2 pieces per cylinder should be ordered.
 Note 2) Each package contains the following parts.
 Foot or Flange style : Body mounting bolt

Applicable Auto Switches

Style	Special function	Electrical entry	Indicator	Wiring (Output)	Load voltage			Auto switch model		Lead wire (m)*			Applicable load											
					DC	AC	Perpendicular	In-line	0.5 (—)	3 (L)	5 (Z)													
Reed switch	—	Grommet	No	2 wire	24V	5V	100V	A90V	A90	●	●	—	IC	Relay PLC										
						12V	100V								A93V	A93	●	●	—					
Reed switch	—	Grommet	Yes	3 wire (Equiv. NPN)	—	5V	—	A96V	A96	●	●	—	IC	—										
						—	—								—	—								
Solid state switch	—	Grommet	Yes	3 wire (NPN)	24V	12V	—	M9NV	M9N	●	●	—	—	Relay PLC										
															Diagnostic indication (2 colour)	3 wire (PNP)	M9PV	M9P	●	●	—			
																	Water resistant (2 colour)	2 wire	M9BV	M9B	●	●	—	
																			3 wire (NPN)	M9NWV	M9NW	●	●	○
																				3 wire (PNP)	M9PWV	M9PW	●	●
																			3 wire (PNP)		M9BWV	M9BW	●	●
																	—	M9BA		—	●	○	—	

* Lead wire length 0.5m — (Example) A93
 3m L (Example) A93L
 5m Z (Example) M9NWZ
 *○: Manufactured upon receipt of order.

Compact Cylinder/Standard: Double Acting Double Rod Series CQSW



JIS symbol



Precautions

Caution

Snap Ring Installation/Removal

- For installation and removal, use an appropriate pair of pliers (Tool for installing a C snap ring.)
- Exercise caution even when using an appropriate pair of pliers, because of the possibility of the snap ring becoming detached from the tip of the pliers and flying away, which could injure humans or damage the peripheral equipment. After installing the snap ring, make sure that it is placed securely in the ring groove before supplying air.

Mounting

- When removing a load, be sure to secure the wrench flats of the piston rod on the load side.
- If this is done without securing the piston rod on the load side, be aware that the coupled (screwed-in) portion of the piston rod could become loosened.

Minimum Operating Pressure Unit: MPa

Bore size(mm)	12	16	20	25
Min. operating pressure	0.07	0.07	0.05	0.05

Allowable Kinetic Energy Unit: J

Bore size(mm)	12	16	20	25
Standard	0.022	0.038	0.055	0.09
Rubber bumper	0.043	0.075	0.11	0.18

Option

Option	Availability
Rod end male thread	Available for all standard models of double acting double rod
Rubber bumper	

Calculation Example: CQSWF12-10DM

- Cylinder weight: CQSWB12-10D.....46g
- Option weight: Rod end male thread.....5g
- Front flange.....58g

Total 109g

Standard Specifications

Style	Pneumatic (Non-lube)
Action	Double acting double rod
Fluid	Air
Proof pressure	1.5MPa
Max. operating pressure	1.0MPa
Ambient and fluid temperature	Without auto switch -10°C to 70°C (No freezing) With auto switch -10°C to 60°C (No freezing)
Rubber bumper	None
Rod end thread	Female thread
Rod end thread tolerance	JIS Class 2
Tolerance of stroke length	$\begin{matrix} +1.0 \\ 0 \end{matrix}$
Mounting	Through hole/Both ends tapped
Operating piston speed	50 to 500mm/s

Minimum Strokes for Auto Switch Mounting

Unit: mm

No. of auto switches	D-A9□, D-M9□WV	D-A9□V	D-M9N	D-M9 ² , D-M9□W	D-M9□V	D-M9BA
2	10	10	15*	20*	5	25*
1	10*	5	15*	20*	5	25*

* Consult SMC for shorter strokes than indicated in the table.

Theoretical Force

Unit: N

Bore size (mm)	Rod diameter (mm)	Operation	Piston area (mm ²)	Operating pressure (MPa)		
				0.3	0.5	0.7
12	6	IN	84.8	25	42	59
		OUT				
16	8	IN	151	45	75	106
		OUT				
20	10	IN	236	71	118	165
		OUT				
25	12	IN	378	113	189	264
		OUT				

Weight/Without Auto Switch

Unit: g

Bore (mm)	Stroke (mm)									
	5	10	15	20	25	30	35	40	45	50
12	38	46	54	62	69	77	—	—	—	—
16	50	61	71	81	92	102	—	—	—	—
20	89	104	120	136	152	167	183	199	215	231
25	127	146	166	186	206	227	247	267	287	308

Weight/With Auto Switch(Built-in magnet)

Unit: g

Bore (mm)	Stroke (mm)									
	5	10	15	20	25	30	35	40	45	50
12	46	54	62	70	77	85	—	—	—	—
16	60	71	81	91	102	112	—	—	—	—
20	119	134	150	166	182	198	214	230	245	261
25	154	174	195	215	235	255	276	296	316	336

Option Weights

Unit: g

Bore size (mm)		12	16	20	25
Rod end male thread	Male thread	3	6	12	24
	Nut	2	4	8	16
Rubber bumper		0	-1	-2	-2
Foot (including bolt)		55	65	159	181
Front flange (including bolt)		58	70	143	180

Series CQSW

Construction

Basic

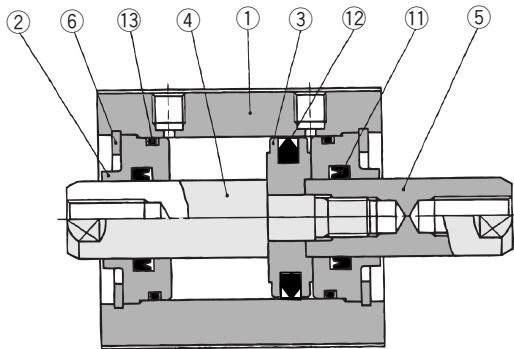

With rubber bumper

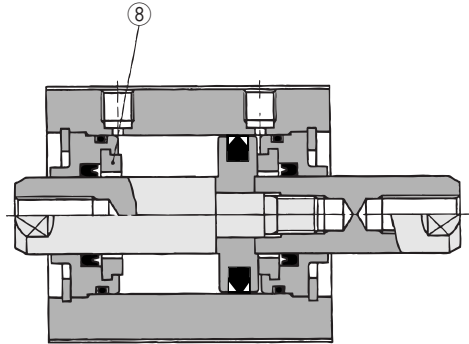

With auto switch (Built-in magnet)

ø12, ø16

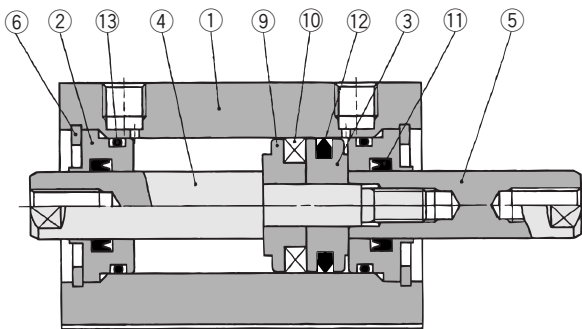

ø20, ø25

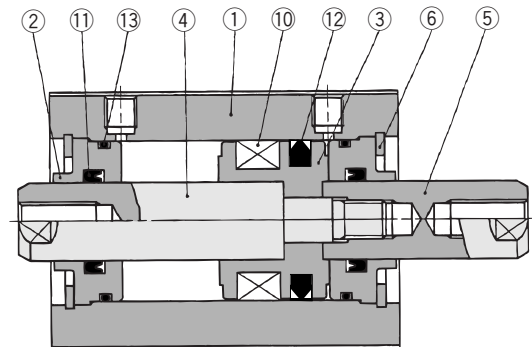

Component Parts

No.	Description	Material	Note
①	Cylinder tube	Aluminum alloy	Hard anodized
②	Collar	Aluminum bearing alloy	Anodized
③	Piston	Aluminum alloy	Chromated
④	Piston rod A	Stainless steel	
⑤	Piston rod B	Stainless steel	
⑥	Snap ring	Carbon tool steel	Phosphate coating
⑦	Rod end nut	Carbon steel	Nickel plated
⑧	Bumper	Urethane	
⑨	Switch spacer	Aluminum alloy	Chromated
⑩	Magnet	—	
⑪	Rod seal	NBR	
⑫	Piston seal	NBR	
⑬	Tube gasket	NBR	

Rod end male thread

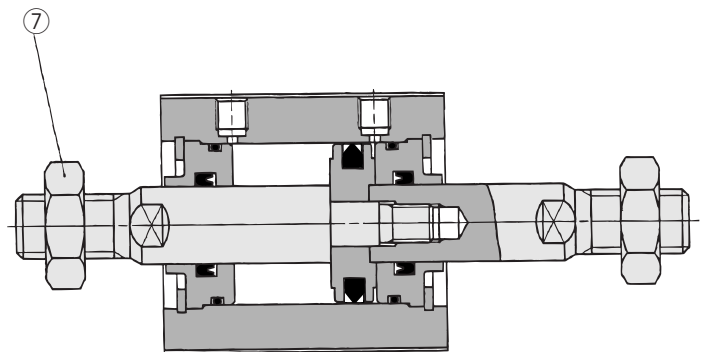

Replacement Parts : Seal Kits

Bore size (mm)	Kit No.	Contents
12	CQSWB12-PS	Kits include items ⑪, ⑫ and ⑬ from the table above.
16	CQSWB16-PS	
20	CQSWB20-PS	
25	CQSWB25-PS	

 *Seal kit consist of items ⑪, ⑫ and ⑬ contained in one kit, and can be ordered using the order number for each respective tube bore size.

Compact Cylinder/Standard: Double Acting Double Rod **Series CQSW**

Mounting Bolt for CQSW

Special long bolt for through-hole mounting is available as an option.

How to Order: Specify the required bolts.

Example) Bolt M3 X 30ℓ 4pcs.

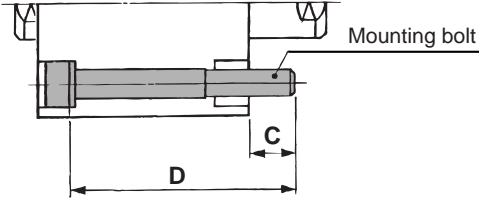

Model	C	D	Mounting bolt	Model	C	D	Mounting bolt
CQSWB12-5D	6.5	30	M3 X 30ℓ	CQSWB20-25D	10	55	M5 X 55ℓ
-10D		35	X 35ℓ	-30D		60	X 60ℓ
-15D		40	X 40ℓ	-35D		65	X 65ℓ
-20D		45	X 45ℓ	-40D		70	X 70ℓ
-25D		50	X 50ℓ	-45D		75	X 75ℓ
-30D		55	X 55ℓ	-50D		80	X 80ℓ
CQSWB16-5D	6.5	30	M3 X 30ℓ	CQSWB25-5D	7	35	M5 X 35ℓ
-10D		35	X 35ℓ	-10D		40	X 40ℓ
-15D		40	X 40ℓ	-15D		45	X 45ℓ
-20D		45	X 45ℓ	-20D		50	X 50ℓ
-25D		50	X 50ℓ	-25D		55	X 55ℓ
-30D		55	X 55ℓ	-30D		60	X 60ℓ
CQSWB20-5D	10	35	M5 X 35ℓ	-35D		65	X 65ℓ
-10D		40	X 40ℓ	-40D		70	X 70ℓ
-15D		45	X 45ℓ	-45D		75	X 75ℓ
-20D		50	X 50ℓ	-50D		80	X 80ℓ



Note) Appropriate plain washer must be used for through-hole mounting.

Mounting Bolt for CDQSW/With Auto Switch

Special long bolt for through-hole mounting is available as an option.

How to Order : Specify the required bolts.

Example) Bolt M3 X 35ℓ 4pcs.

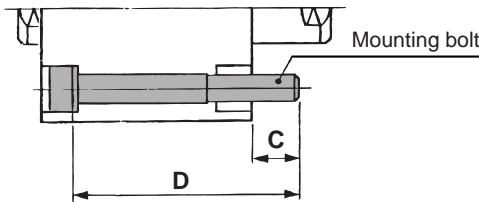

Model	C	D	Mounting bolt	Model	C	D	Mounting bolt
CDQSWB12-5D	6.5	35	M3 X 35ℓ	CDQSWB20-25D	10	65	M5 X 65ℓ
-10D		40	X 40ℓ	-30D		70	X 70ℓ
-15D		45	X 45ℓ	-35D		75	X 75ℓ
-20D		50	X 50ℓ	-40D		80	X 80ℓ
-25D		55	X 55ℓ	-45D		85	X 85ℓ
-30D		60	X 60ℓ	-50D		90	X 90ℓ
CDQSWB16-5D	6.5	35	M3 X 35ℓ	CDQSWB25-5D	7	45	M5 X 45ℓ
-10D		40	X 40ℓ	-10D		50	X 50ℓ
-15D		45	X 45ℓ	-15D		55	X 55ℓ
-20D		50	X 50ℓ	-20D		60	X 60ℓ
-25D		55	X 55ℓ	-25D		65	X 65ℓ
-30D		60	X 60ℓ	-30D		70	X 70ℓ
CDQSWB20-5D	10	45	M5 X 45ℓ	-35D		75	X 75ℓ
-10D		50	X 50ℓ	-40D		80	X 80ℓ
-15D		55	X 55ℓ	-45D		85	X 85ℓ
-20D		60	X 60ℓ	-50D		90	X 90ℓ



Note) Appropriate plain washer must be used for through-hole mounting.

Series CQSW

Dimensions/ø12 to ø25

Basic (Through-hole/Both ends tapped)/CQSWB, CDQSWB

ø12

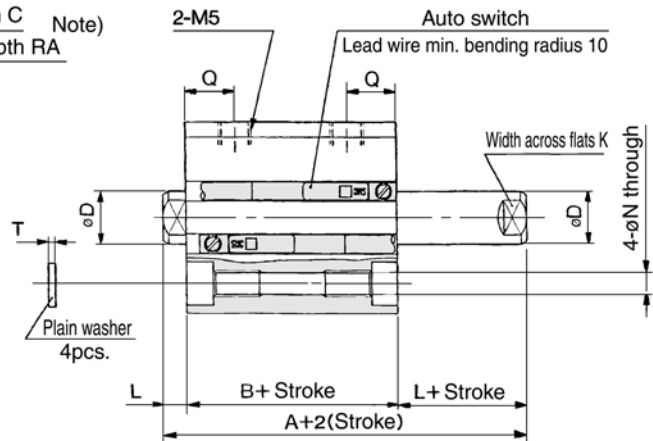
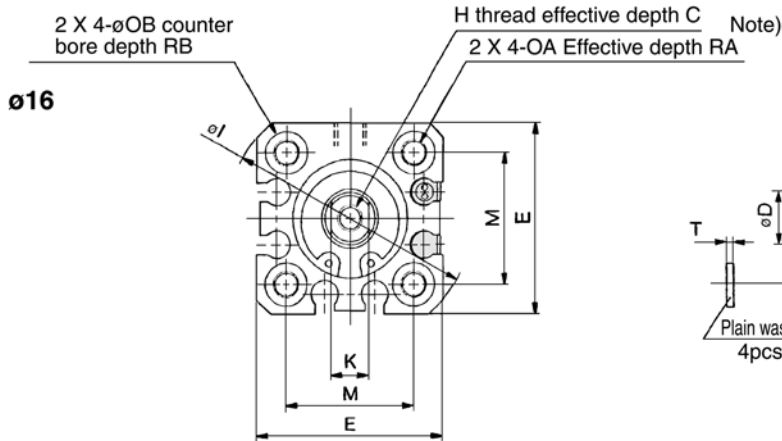
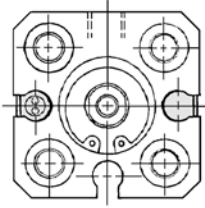

ø20, ø25

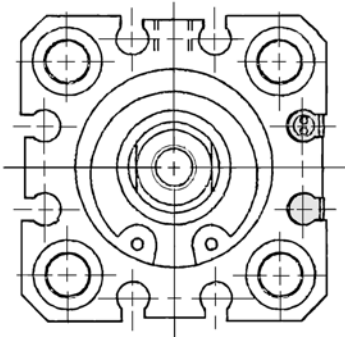

Rod end male thread

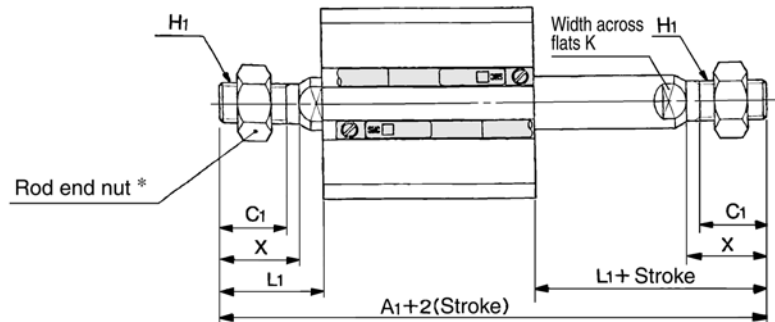

Rod end male thread (All dimensions are common except "A".)

Bore (mm)	W/o auto switch		With auto switch		C ₁	H ₁	L ₁	X
	A ₁	B ₁	A ₁	B ₁				
12	50	22	55	27	9	M5	14	10.5
16	53	22	58	27	10	M6	15.5	12
20	63	26	73	36	12	M8	18.5	14
25	74	29	84	39	15	M10 X 1.25	22.5	17.5

Basic

(All dimensions are common except "A" and "B".)

Bore (mm)	Stroke range (mm)	W/o auto switch		With auto switch		C	D	E	H	I	K	L	M	N	OA	OB	Q	RA	RB	T
		A	B	A	B															
12	5 to 30	29	22	34	27	6	6	25	M3	32	5	3.5	15.5	3.5	M4	6.5	7.5	7	4	0.5
16	5 to 30	29	22	34	27	8	8	29	M4	38	6	3.5	20	3.5	M4	6.5	7.5	7	4	0.5
20	5 to 50	35	26	45	36	7	10	36	M5	47	8	4.5	25.5	5.4	M6	9	9	10	7	1
25	5 to 50	39	29	49	39	12	12	40	M6	52	10	5	28	5.4	M6	9	11	10	7	1

Note 1) For the following bore/stroke sizes, through-hole is threaded over the entire length: Basic ø20, ø25; stroke.

Note 2) Rubber bumper style has the same dimensions as those indicated above.

* Refer to p.1-442 for detail of the rod end nut and mounting brackets.

Compact Cylinder/Standard: Double Acting Double Rod **Series CQSW**

Foot/CQSWL, CDQSWL

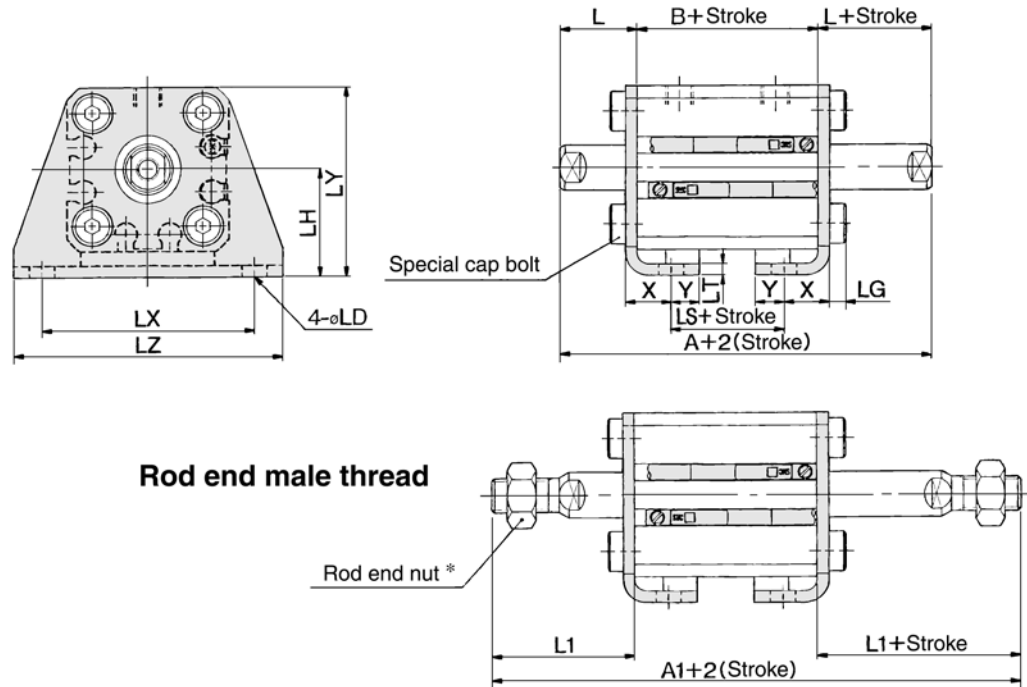

Foot

(All dimensions are common except "A", "A1", "B" and "LS".)

Bore (mm)	Stroke range (mm)	Without auto switch				With auto switch				L	L1	LD	LG	LH	LT	LX	LY	LZ	X	Y
		A	A1	B	LS	A	A1	B	LS											
12	5 to 30	49	70	22	10	54	75	27	15	13.5	24	4.5	2.8	17	2	34	29.5	44	8	4.5
16	5 to 30	49	73	22	10	54	78	27	15	13.5	25.5	4.5	2.8	19	2	38	33.5	48	8	5
20	5 to 50	55	83	26	14	65	93	36	24	14.5	28.5	6.6	4	24	3.2	48	42	62	9.2	5.8
25	5 to 50	59	94	29	14	69	104	39	24	15	32.5	6.6	4	26	3.2	52	46	66	10.7	5.8

Flange/CQSWF, CDQSWF

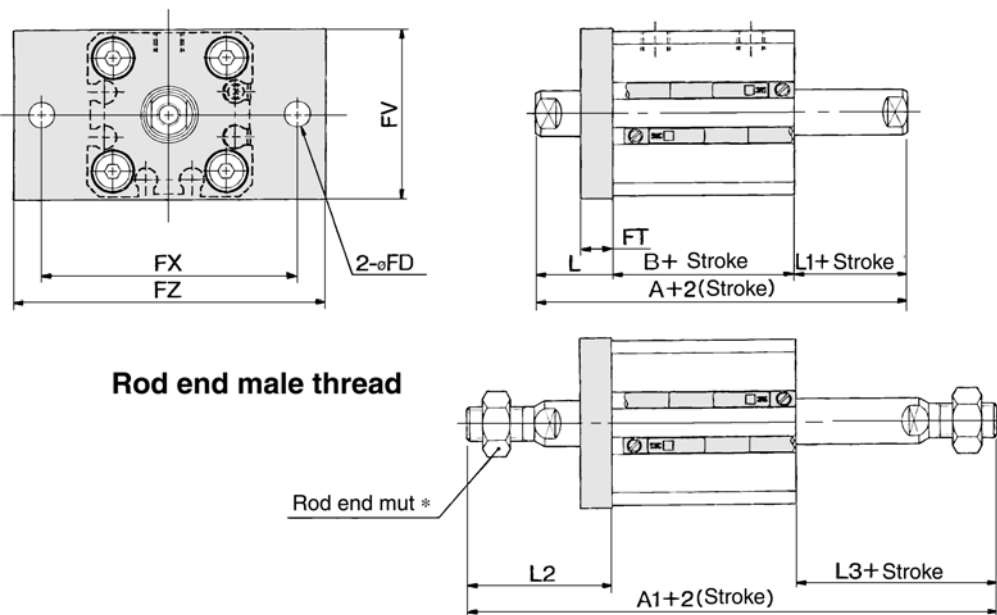

Flange

(All dimensions are common except "A", "A1" and "B".)

Bore (mm)	Stroke range (mm)	Without auto switch			With auto switch			FD	FT	FV	FX	FZ	L	L1	L2	L3
		A	A1	B	A	A1	B									
12	5 to 30	39	60	22	44	65	27	4.5	5.5	25	45	55	13.5	3.5	24	14
16	5 to 30	39	63	22	44	68	27	4.5	5.5	30	45	55	13.5	3.5	25.5	15.5
20	5 to 50	45	73	26	55	83	36	6.6	8	39	48	60	14.5	4.5	28.5	18.5
25	5 to 50	49	84	29	59	94	39	6.6	8	42	52	64	15	5	32.5	22.5

* Refer to p.1-442 for detail of the rod end nut and mounting brackets.

Compact Cylinder/Standard: Single Acting Spring Return/Extend

Series CQS

ø12, ø16, ø20, ø25

How to Order

Standard

CQS **B** **20** **10** **S**

With auto switch

CDQS **B** **20** **10** **S** **A90** **S**

With auto switch
(Built-in magnet)

Mounting style

B	Through-hole/Both ends tapped (Standard)
L	Foot
F	Front flange
G	Rear flange
D	Double clevis

* Mounting brackets are shipped not assembled with the cylinder.

Bore size

12	12mm
16	16mm
20	20mm
25	25mm

Cylinder stroke (mm)

Standard stroke

Bore size (mm)	Standard stroke (mm)
12, 16, 20, 25	5, 10

Number of auto switches

—	2
S	1
n	n

Auto switch

—	Without auto switch (Built-in magnet)
---	---------------------------------------

* Refer to table below for auto switch model No.

Option

—	Standard (Rod end female thread)
M	Rod end male thread

Action

S	Single acting spring return
T	Single acting spring extend

Mounting Bracket Part No.

Bore size (mm)	Foot ⁽¹⁾	Flange	Double clevis
12	CQS-L012	CQS-F012	CQS-D012
16	CQS-L016	CQS-F016	CQS-D016
20	CQS-L020	CQS-F020	CQS-D020
25	CQS-L025	CQS-F025	CQS-D025



- Note 1) 2 pieces per cylinder should be ordered.
 Note 2) Each package contains the following parts.
 Foot or Flange style: Body mounting bolt
 Double clevis: Clevis pin, snap ring retainer, body mounting bolt.

Applicable Auto Switches

Style	Special function	Elec-trical entry	Indicator	Wiring (Output)	Load voltage		Auto switch model		Lead wire (m)*			Applicable load	
					DC	AC	Perpendicular	In-line	0.5 (—)	3 (L)	5 (Z)		
													A90V
Reed switch	—	Grommet	No	2 wire	24V	5V	100V ≤	A90V	A90	●	●	—	IC
						12V	100V	A93V	A93	●	●	—	Relay PLC
Solid state switch	—	Grommet	Yes	3 wire (Equiv. NPN)	24V	12V	—	A96V	A96	●	●	—	IC
								M9NV	—	●	●	—	Relay PLC
								M9PV	—	●	●	—	
								M9BV	—	●	●	—	
								M9NWV	—	●	●	○	
								M9PWV	—	●	●	○	
Diagnostic indication (2 colour)	—	Grommet	Yes	3 wire (PNP)	24V	12V	—	M9BWV	—	●	●	○	
								M9BWV	—	●	●	○	

* Lead wire length 0.5m — (Example) A93
 3m L (Example) A93L
 5m Z (Example) M9NWZ

* Solid state switches marked with a "○" are manufactured upon receipt of order.

Compact Cylinder/Standard: Single Acting Spring Return/Extend Series CQS



JIS symbol

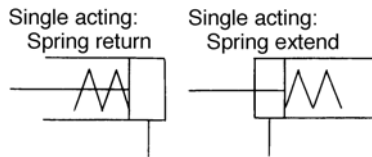

Standard Specifications

Style	Pneumatic (Non-lube)
Action	Single acting, single rod
Fluid	Air
Proof pressure	1.5MPa
Max. operating pressure	1.0MPa
Ambient and fluid temperature	Without auto switch: -10°C to 70°C (No freezing) With auto switch: -10°C to 60°C (No freezing)
Rubber bumper	None
Rod end nut	Female thread
Tolerance of rod end thread	JIS Class 2
Tolerance of stroke length	$\begin{matrix} +1.0 \\ 0 \end{matrix}$
Mounting	Through hole/Both ends tapped
Operating piston speed	50 to 500mm/s

Minimum Strokes for Auto Switch Mounting

Unit: mm

No. of auto switches	D-A9□, D-M9□WV	D-A9□V	D-M9□V
2	10	10	5
1	10 ⁽¹⁾	5	5

Note 1) Consult SMC for shorter stroke length than indicated in the table.

Theoretical Force

Unit: N

Action	Bore size (mm)	Rod diameter (mm)	Operation	Piston area (mm ²)	Operating press (MPa)			Beginning	Ending
					0.3	0.5	0.7		
Spring return	12	6	IN	—	20	43	65	14	4
			OUT	113					
	16	8	IN	—	45	86	126	15	6
			OUT	201					
	20	10	IN	—	78	141	204	15	6
			OUT	314					
	25	12	IN	—	126	224	323	21	11
			OUT	491					
Spring extend	12	6	IN	84.8	14	31	48	10	3
			OUT	—					
	16	8	IN	151	24	54	85	19	4
			OUT	—					
	20	10	IN	236	44	91	138	27	5
			OUT	—					
	25	12	IN	378	84	160	235	29	10
			OUT	—					

Caution

Snap Ring Installation/Removal

- For installation and removal, use an appropriate pair of pliers (Tool for installing a C snap ring).
- Exercise caution even when using an appropriate pair of pliers because of the possibility of the snap ring becoming detached from the tip of the pliers and flying away, which could injure humans or damage the peripheral equipment. After installing the snap ring, make sure that it is placed securely in the ring groove before supplying air.

Allowable Kinetic Energy

Unit: J

Bore size (mm)	12	16	20	25
Standard	0.022	0.038	0.055	0.09
Rubber bumper	0.043	0.075	0.11	0.18

Min. Operating Pressure

Unit: MPa

Bore size (mm)	12	16	20	25
Min. operating pressure	0.25	0.25	0.18	0.18

Option

Option	Availability
Rod end male thread	Available for all standard models of single acting single rod.

Example) CQSG16-10S

- Cylinder weight: CQSB16-10S.....48g
- : Rear flange.....66g

Total 114g

Weight/Without Auto Switch

Spring return (Spring extend) Unit: g

Bore size (mm)	Stroke (mm)	
	5	10
12	29(31)	36(37)
16	39(39)	48(47)
20	63(68)	76(79)
25	92(98)	108(113)

*(): Spring extend

Weight/With Auto Switch (Built-in magnet)

Spring return (Spring extend) Unit: g

Bore size (mm)	Stroke (mm)	
	5	10
12	37(39)	44(45)
16	49(51)	58(59)
20	94(104)	107(115)
25	130(150)	146(165)

*(): Spring extend

Option Weights

Unit: g

Bore size (mm)		12	16	20	25
Rod end male thread	Male thread	1.5	3	6	12
	Nut	1	2	4	8
Foot (including bolt)		55	65	159	181
Front flange (including bolt)		58	70	143	180
Rear flange (including bolt)		56	66	137	171
Double clevis (including pin, snap ring, bolt)		34	40	92	127

Series CQS

Construction

Single acting/Spring return

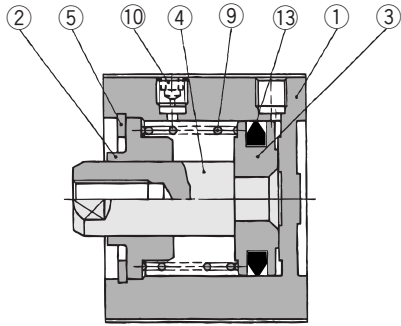

Single acting/Spring extend

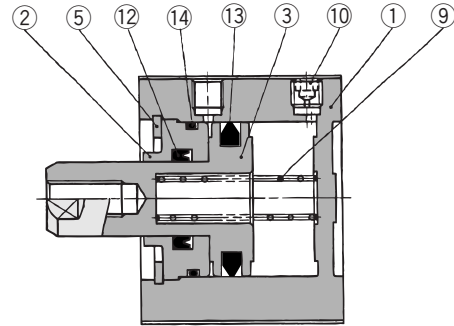

Single acting/Spring return/With auto switch (Built-in magnet)

ø12, ø16

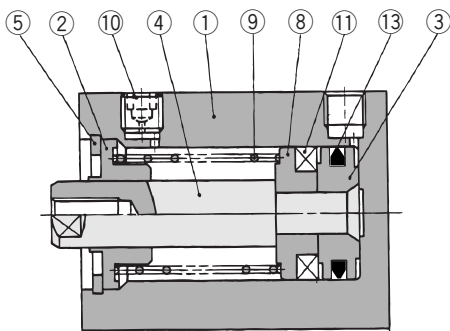

Single acting/Spring extend/With auto switch (Built-in magnet)

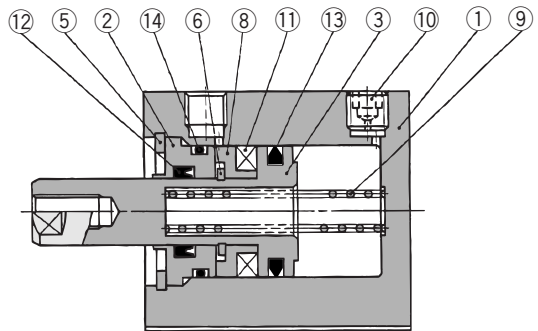

ø20, 25

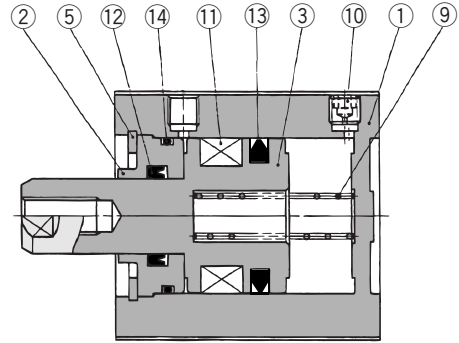
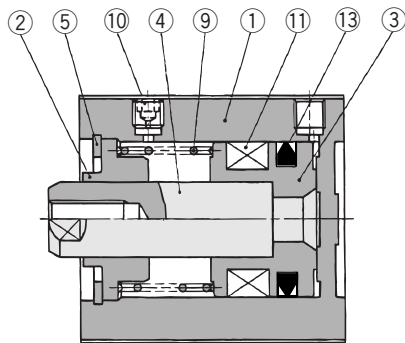

Component Parts

No.	Description	Material	Note
①	Cylinder tube	Aluminum alloy	Hard anodized
②	Collar	Aluminum bearing alloy	Anodized
③	Piston	Aluminum alloy	Spring return
		Stainless steel	Spring extend
④	Piston rod	Stainless steel	
⑤	Snap ring	Carbon tool steel	Phosphate coating
⑥	Snap ring	Carbon tool steel	Nickel plated
⑦	Rod end nut	Carbon steel	Nickel plated
⑧	Switch spacer	Aluminum alloy	Chromated
⑨	Return spring	Piano wire	Zinc chromated
⑩	Plug with fixed orifice	Alloy steel	Nickel plated
⑪	Magnet	—	
⑫*	Rod seal	NBR	
⑬*	Piston seal	NBR	
⑭*	Tube gasket	NBR	

Replacement Parts: Seal Kits

Action	Bore size (mm)	Kit No.	Contents
Single acting Spring return	12	CQSB12-S-PS	Kits include item ⑬ from the table above.
	16	CQSB16-S-PS	
	20	CQSB20-S-PS	
	25	CQSB25-S-PS	

* Seal kits consist of item ⑬ contained in one kit, and can be ordered using the kit number for each respective tube bore size.

Rod end nut

Spring return

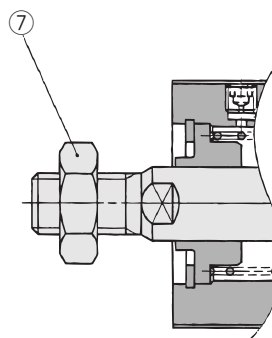

Spring extend

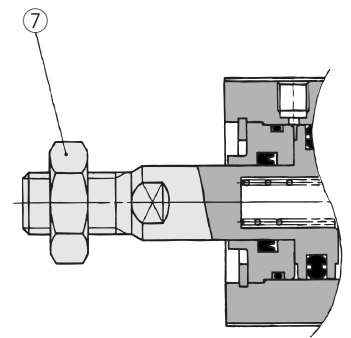

Replacement Parts: Seal Kits

Action	Bore size (mm)	Kit No.	Contents
Single acting Spring extend	12	CQSB12-T-PS	Kits include items ⑫, ⑬ and ⑭ from the table above.
	16	CQSB16-T-PS	
	20	CQSB20-T-PS	
	25	CQSB25-T-PS	

* Seal kits consist of items ⑫, ⑬ and ⑭ contained in one kit, and can be ordered using the kit number for each respective tube bore size.

Compact Cylinder/Standard: Single Acting Spring Return/Extend Series CQS

Mounting Bolt for CQS

Special long bolt for through-hole mounting is available as an option

How to Order: Specify the required bolts
Example) Bolt M3 X 25 ℓ 4pcs.

Single acting/Spring return

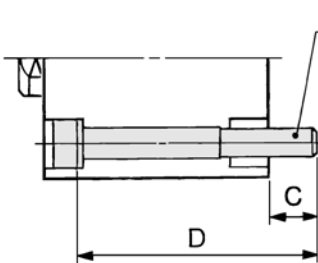

Single acting/Spring extend

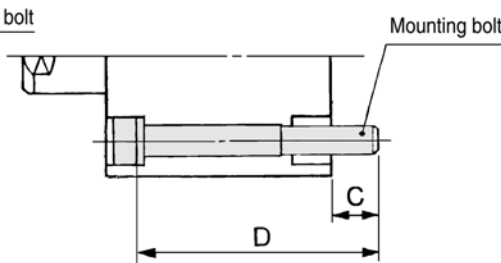

Single acting/Spring return

Model	C	D	Mounting bolt
CQSB12-5S	6.5	25	M3 X 25 ℓ
-10S		30	X 30 ℓ
CQSB16-5S	6.5	25	M3 X 25 ℓ
-10S		30	X 30 ℓ
CQSB20-5S	6.5	25	M5 X 25 ℓ
-10S		30	X 30 ℓ
CQSB25-5S	8.5	30	M5 X 30 ℓ
-10S		35	X 35 ℓ

Single acting/Spring extend

Model	C	D	Mounting bolt
CQSB12-5T	6.5	25	M3 X 25 ℓ
-10T		30	X 30 ℓ
CQSB16-5T	6.5	25	M3 X 25 ℓ
-10T		30	X 30 ℓ
CQSB20-5T	6.5	25	M5 X 25 ℓ
-10T		30	X 30 ℓ
CQSB25-5T	8.5	30	M5 X 30 ℓ
-10T		35	X 35 ℓ



Note) The appropriate plain washer must be used for through-hole mounting.

Mounting Bolt for CDQS

Special long bolt for through-hole mounting is available as an option

How to Order: Specify the required bolts
Example) Bolt M3 X 30 ℓ 4pcs.

Single acting/Spring return

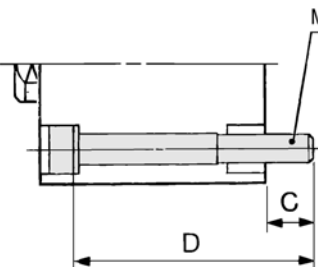

Single acting/Spring extend

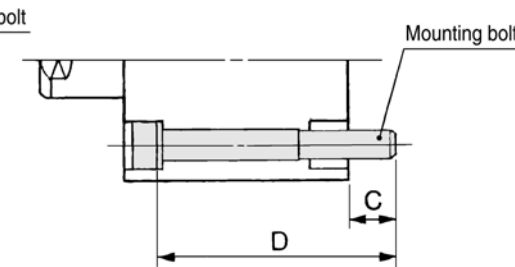

Single acting/Spring return

Model	C	D	Mounting bolt
CDQSB12-5S	6.5	30	M3 X 30 ℓ
-10S		35	X 35 ℓ
CDQSB16-5S	6.5	30	M3 X 30 ℓ
-10S		35	X 35 ℓ
CDQSB20-5S	6.5	35	M5 X 35 ℓ
-10S		40	X 40 ℓ
CDQSB25-5S	8.5	40	M5 X 40 ℓ
-10S		45	45 ℓ

Single acting/Spring extend

Model	C	D	Mounting bolt
CDQSB12-5T	6.5	30	M3 X 30 ℓ
-10T		35	X 35 ℓ
CDQSB16-5T	6.5	30	M3 X 30 ℓ
-10T		35	X 35 ℓ
CDQSB20-5T	6.5	35	M5 X 35 ℓ
-10T		40	X 40 ℓ
CDQSB25-5T	8.5	40	M5 X 40 ℓ
-10T		45	X 45 ℓ



Note) The appropriate plain washer must be used for through-hole mounting.

Series CQS

Dimensions/ø12 to ø25: Spring Return

Basic (Through-hole/Both ends tapped)/CQSB, CDQSB

ø12

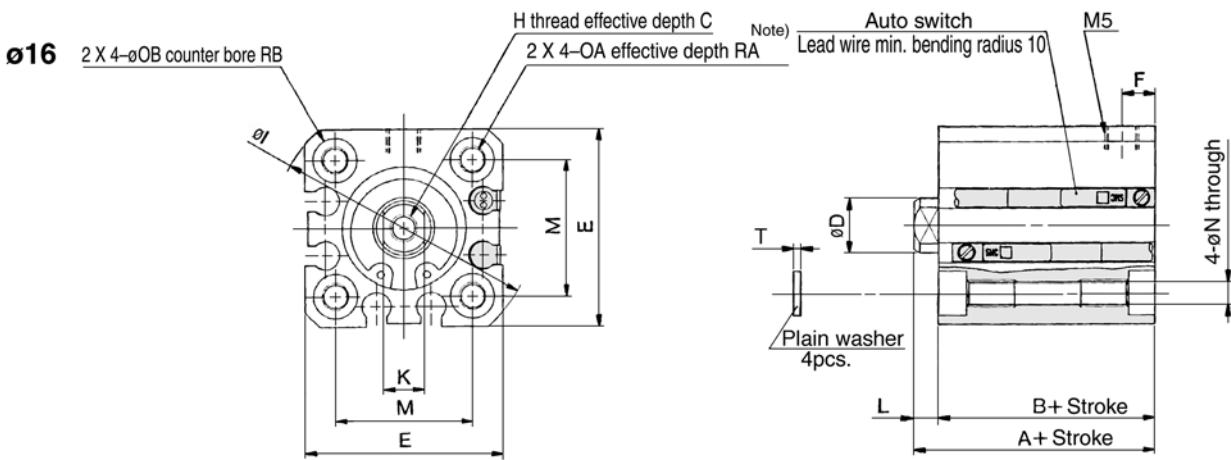
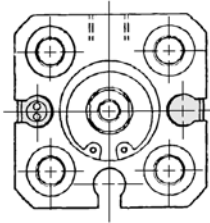

ø20, ø25

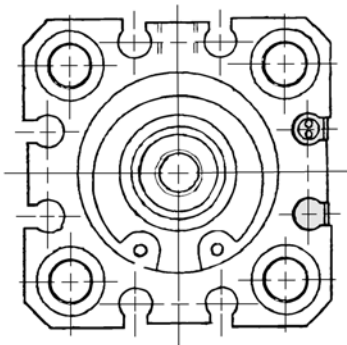

Rod end male thread

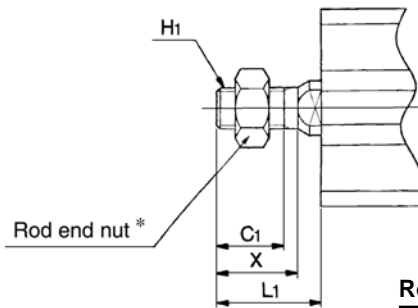

Rod end male thread

Bore (mm)	C ₁	H ₁	L ₁	X
12	9	M5	14	10.5
16	10	M6	15.5	12
20	12	M8	18.5	14
25	15	M10 X 1.25	22.5	17.5

Basic

(All dimensions are common except "A" and "B".)

Bore (mm)	Stroke range (mm)	Without auto switch				With auto switch				C	D	E	F	H	I	K	L	M	N	OA	OB	RA	RB	T
		A		B		A		B																
		5 ST	10 ST	5 ST	10 ST	5 ST	10 ST	5 ST	10 ST															
12	5, 10	25.5	30.5	22	27	30.5	35.5	27	32	6	6	25	5	M3	32	5	3.5	15.5	3.5	M4	6.5	7	4	0.5
16		25.5	30.5	22	27	30.5	35.5	27	32	8	8	29	5	M4	38	6	3.5	20	3.5	M4	6.5	7	4	0.5
20		29	34	24.5	29.5	39	44	34.5	39.5	7	10	36	5.5	M5	47	8	4.5	25.5	5.4	M6	9	10	7	1
25		32.5	37.5	27.5	32.5	42.5	47.5	37.5	42.5	12	12	40	5.5	M6	52	10	5	28	5.4	M6	9	10	7	1

Note) Basic: For the following bore/stroke sizes, through-hole is threaded over the entire length.

ø12 and ø16; 5 stroke, ø20 and ø25; 5 to 10 stroke

(With auto switch (Built-in magnet): ø20; 5 stroke

* Refer to p.1-442 for details of the rod end nut and mounting brackets.

Compact Cylinder/Standard: Single Acting Spring Return/Extend **Series CQS**

Foot/CQSL, CDQSL

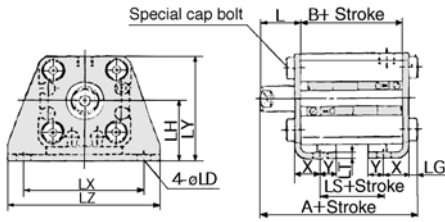

(All dimensions are common between standard stroke and long stroke except "A", "B" and "LS".)

Stroke range (mm)	W/o auto switch			With auto switch			L	L ₁	LD	LG	LH	LT	LX	LY	LZ	X	Y
	A	B	LS	A	B	LS											
10	35.3	17	5	40.3	22	10	13.5	24	4.5	2.8	17	2	34	29.5	44	8	4.5
	35.3	17	5	40.3	22	10	13.5	25.5	4.5	2.8	19	2	38	33.5	48	8	5
	41.2	19.5	7.5	51.2	29.5	17.5	14.5	28.5	6.6	4	24	3.2	48	42	62	9.2	5.8
	44.7	22.5	7.5	54.7	32.5	17.5	15	32.5	6.6	4	26	3.2	52	46	66	10.7	5.8

Rod end nut

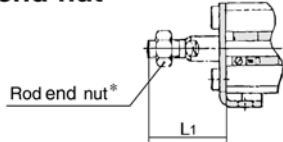

Front flange/CQSF, CDQSF

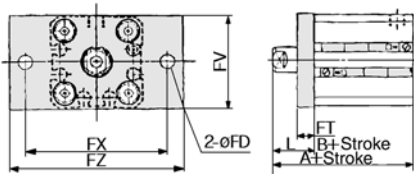

(All dimensions are common between standard stroke and long stroke except "A" and "B".)

Stroke range (mm)	W/o auto switch		With auto switch		FD	FT	FV	FX	FZ	L	L ₁
	A	B	A	B							
5, 10	30.5	17	35.5	22	4.5	5.5	25	45	55	13.5	24
	30.5	17	35.5	22	4.5	5.5	30	45	55	13.5	25.5
	34	19.5	44	29.5	6.6	8	39	48	60	14.5	28.5
	37.5	22.5	47.5	32.5	6.6	8	42	52	64	15	32.5

Rod end nut

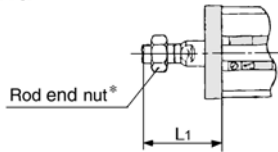

Rear flange mounting/CQSG, CDQSG

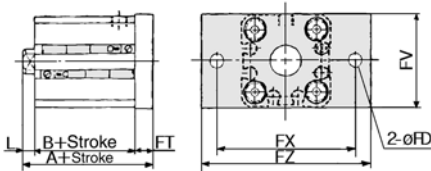

(All dimensions are common between standard stroke and long stroke except "A" and "B".)

Stroke range (mm)	W/o auto switch		With auto switch		FD	FT	FV	FX	FZ	L	L ₁
	A	B	A	B							
5, 10	26	17	31	22	4.5	5.5	25	45	55	3.5	14
	26	17	31	22	4.5	5.5	30	45	55	3.5	15.5
	32	19.5	42	29.5	6.6	8	39	48	60	4.5	18.5
	35.5	22.5	45.5	32.5	6.6	8	42	52	64	5	22.5

Rod end nut

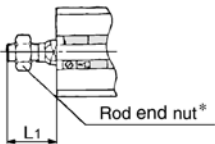

Double clevis/CQSD, CDQSD

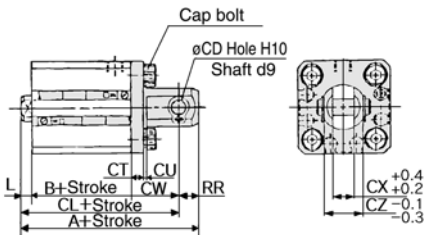

(All dimensions are common between standard stroke and long stroke except "A", "B" and "CL".)

Stroke range (mm)	W/o auto switch			With auto switch			CD	CT	CU	CW	CX	CZ	L	L ₁	RR
	A	B	CL	A	B	CL									
5, 10	40.5	17	34.5	45.5	22	39.5	5	4	7	14	5	10	3.5	14	6
	41.5	17	35.5	46.5	22	40.5	5	4	10	15	6.5	12	3.5	15.5	6
	51	19.5	42	61	29.5	52	8	5	12	18	8	16	4.5	18.5	9
	57.5	22.5	47.5	67.5	32.5	57.5	10	5	14	20	10	20	5	22.5	10

Rod end nut

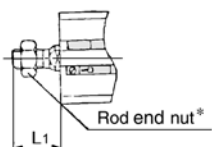

1-442 for detail of the rod end nut and mounting brackets.

Series CQS

Dimensions/ø12 to ø25: Spring Extend

Basic (Through-hole/Both ends tapped)/CQSB, CDQSB

ø12

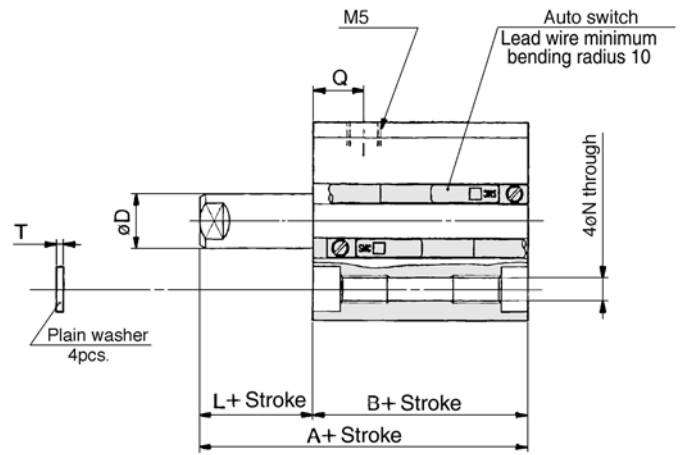
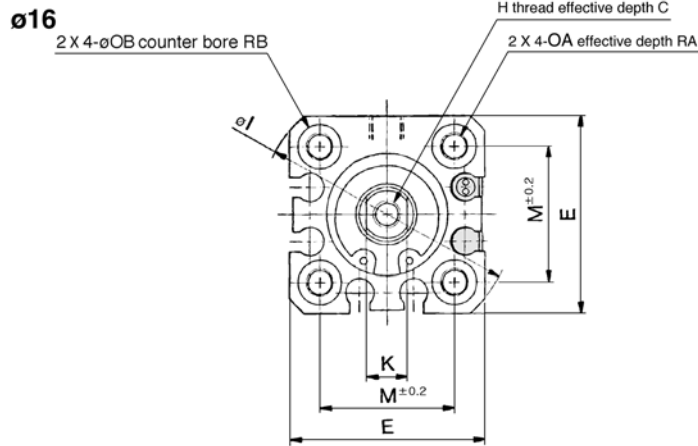
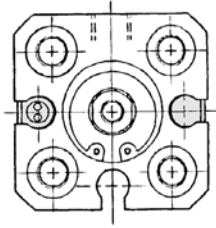

ø20, ø25

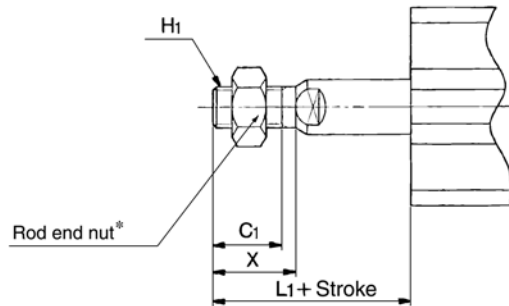
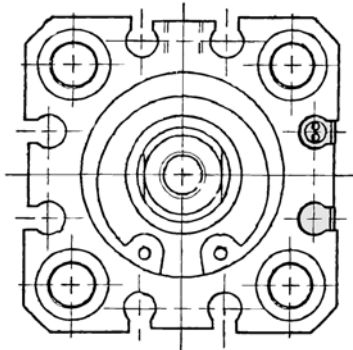

Rod end male thread

Rod end male thread

Bore (mm)	C ₁	H ₁	L ₁		X
			5 ST	10 ST	
12	9	M5	19	24	10.5
16	10	M6	20.5	25.5	12
20	12	M8	23.5	28.5	14
25	15	M10 X 1.25	27.5	32.5	17.5

Basic

(All dimensions are common between standard stroke and long stroke except "A" and "B".)

Bore (mm)	Stroke range (mm)	Without auto switch				With auto switch				C	D	E	H	I	K	L		M	N	OA	OB	Q	RA	RB	T
		A		B		A		B								5 ST	10 ST								
		5 ST	10 ST	5 ST	10 ST	5 ST	10 ST	5 ST	10 ST																
12	5, 10	30.5	40.5	22	27	35.5	45.5	27	32	6	6	25	M3	32	5	8.5	13.5	15.5	3.5	M4	6.5	7.5	7	4	0.5
		30.5	40.5	22	27	35.5	45.5	27	32	8	8	29	M4	38	6	8.5	13.5	20	3.5	M4	6.5	7.5	7	4	0.5
		34	44	24.5	29.5	44	54	34.5	39.5	7	10	36	M5	47	8	9.5	14.5	25.5	5.4	M6	9	9	10	7	1
25		37.5	47.5	27.5	32.5	47.5	57.5	37.5	42.5	12	12	40	M6	52	10	10	15	28	5.4	M6	9	11	10	7	1



Note) For the following bore/stroke sizes, through-hole is threaded over the entire length.

Basic ø12 and ø16; 5 stroke, ø20 and ø25; 5 to 10 stroke

With auto switch (Built-in magnet)/ø20; 5 stroke.

*Refer to p.1-442 for detail of the rod end nut and mounting brackets.

Compact Cylinder/Standard: Single Acting Spring Return/Extend **Series CQS**

Foot/CQSL, CDQSL

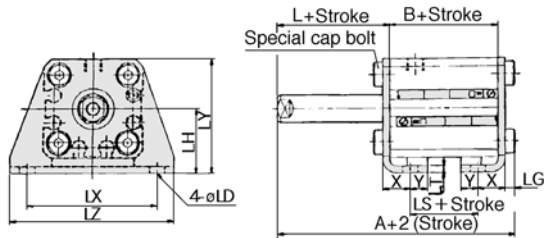

Rod end male thread

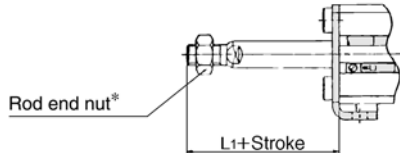

Front flange/CQSF, CDQSF

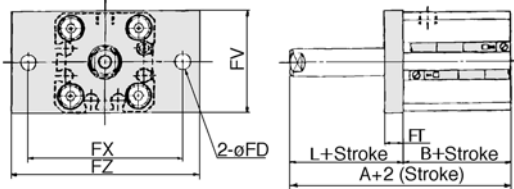

Rod end male thread

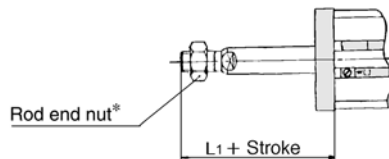

Rear flange/CQSG, CDQSG

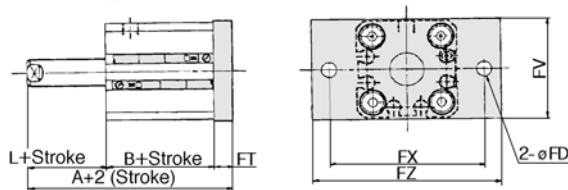

Rod end male thread

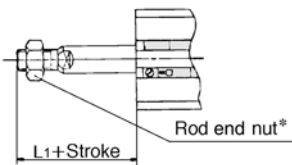

Double clevis/CQSD, CDQSD

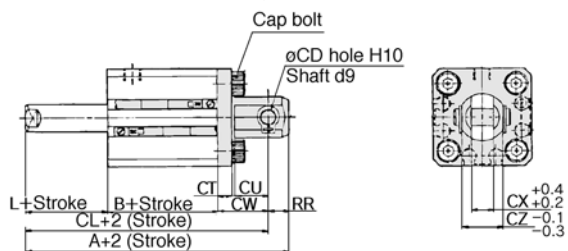

Rod end male thread

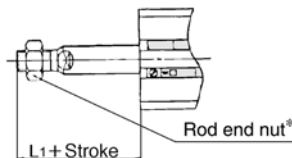

Foot

(All dimensions are common between standard stroke and long stroke except "A", "B" and "LS".)

Bore (mm)	Stroke range (mm)	Without auto switch			With auto switch			LX	LY	LZ	X	Y
		A	B	LS	A	B	LS					
12	5, 10	35.3	17	5	40.3	22	10	34	29.5	44	8	4.5
16		35.3	17	5	40.3	22	10					
20		41.2	19.5	7.5	51.2	29.5	17.5					
25		44.7	22.5	7.5	54.7	32.5	17.5					

Bore (mm)	L	L ₁	LD	LG	LH	LT	LX	LY	LZ	X	Y
12	13.5	24	4.5	2.8	17	2	34	29.5	44	8	4.5
16	13.5	25.5	4.5	2.8	19	2	38	33.5	48	8	5
20	14.5	28.5	6.6	4	24	3.2	48	42	62	9.2	5.8
25	15	32.5	6.6	4	26	3.2	52	46	66	10.7	5.8

Front flange

(All dimensions are common between standard stroke and long stroke except "A" and "B".)

Bore (mm)	Stroke range (mm)	Wo auto switch		With auto switch		FD	FT	FV	FX	FZ	L	L ₁
		A	B	A	B							
12	5, 10	30.5	17	35.5	22	4.5	5.5	25	45	55	13.5	24
16		30.5	17	35.5	22	4.5	5.5	30	45	55	13.5	25.5
20		34	19.5	44	29.5	6.6	8	39	48	60	14.5	28.5
25		37.5	22.5	47.5	32.5	6.6	8	42	52	64	15	32.5

Rear flange

(All dimensions are common between standard stroke and long stroke except "A" and "B".)

Bore (mm)	Stroke range (mm)	Wo auto switch		With auto switch		FD	FT	FV	FX	FZ	L	L ₁
		A	B	A	B							
12	5, 10	26	17	31	22	4.5	5.5	25	45	55	3.5	14
16		26	17	31	22	4.5	5.5	30	45	55	3.5	15.5
20		32	19.5	42	29.5	6.6	8	39	48	60	4.5	18.5
25		35.5	22.5	45.5	32.5	6.6	8	42	52	64	5	22.5

Double clevis

(All dimensions are common between standard stroke and long stroke except "A", "B" and "CL".)

Bore (mm)	Stroke range (mm)	Without auto switch			With auto switch			L	L ₁	RR
		A	B	CL	A	B	CL			
12	5, 10	40.5	17	34.5	45.5	22	39.5	3.5	14	6
16		41.5	17	35.5	46.5	22	40.5			
20		51	19.5	42	61	29.5	52			
25		57.5	22.5	47.5	67.5	32.5	57.5			

Bore (mm)	CD	CT	CU	CW	CX	CZ	L	L ₁	RR
12	5	4	7	14	5	10	3.5	14	6
16	5	4	10	15	6.5	12	3.5	15.5	6
20	8	5	12	18	8	16	4.5	18.5	9
25	10	5	14	20	10	20	5	22.5	10

*Refer to p.1-442 for detail of the rod end nut and mounting brackets.

Compact Cylinder/Non-rotating Rod: Double Acting Single Rod

Series CQSK

ø12, ø16, ø20, ø25

How to Order

Standard CQSK B 20 30 D

With auto switch CDQSK B 20 30 D A90 S

With auto switch (Built-in magnet)

Mounting style

B	Through-hole/Both ends tapped (Standard)
L	Foot
F	Front flange
G	Rear flange
D	Double clevis

Bore size

12	12mm
16	16mm
20	20mm
25	25mm

* Mounting brackets are shipped not assembled with the cylinder.

Number of auto switches

—	2
S	1
n	n

Auto switch

—	Without auto switch (Built-in magnet)
---	---------------------------------------

* Refer to table below for auto switch model no.

Option

—	Standard (Rod end female thread)
M	Rod end male thread

Action

D	Double acting
---	---------------

Cylinder stroke (mm)

Standard stroke

Bore (mm)	Standard stroke (mm)
12, 16	5, 10, 15, 20, 25, 30
20, 25	5, 10, 15, 20, 25, 30, 35, 40, 45, 50

Intermediate strokes at 1mm intervals are available by using spacers with standard stroke cylinders. Intermediate stroke model has the same body length as standard model whose stroke is longer than that of the intermediate model.
Example) CQSKB25-47D: CQSKB25-50D with 3mm width spacer inside.

Mounting Bracket Part No.

Bore size (mm)	Foot ⁽¹⁾	Flange	Double clevis
12	CQSK-L012	CQSK-F012	CQSK-D012
16	CQSK-L016	CQSK-F016	CQSK-D016
20	CQSK-L020	CQSK-F020	CQSK-D020
25	CQSK-L025	CQSK-F025	CQSK-D025

Note 1) 2 pieces per cylinder should be ordered.
Note 2) Each package contains the following parts.
Foot or Flange style: Body mounting bolt
Double clevis style: Clevis pin, snap ring retainer, body mounting bolt.

Double acting double rod model is now available. Consult SMC for the detail.

Applicable Auto Switch

Style	Special function	Electrical entry	Indicator	Wiring (Output)	Load voltage		Auto switch model		Lead wire (m)*			Applicable load		
					DC	AC	Perpendicular	In-line	0.5 (—)	3 (L)	5 (Z)			
														24V
Reed switch	—	Grommet	No	2 wire	24V	5V	100V or less	A90V	A90	●	●	—	IC	Relay PLC
						12V	100V	A93V	A93	●	●	—	—	
Reed switch	—	Grommet	Yes	3 wire (Equiv. NPN)	—	5V	—	A96V	A96	●	●	—	IC	—
								—	—	—	—	—	—	—
Solid state switch	—	Grommet	Yes	3 wire (NPN)	24V	12V	—	M9NV	M9N	●	●	—	—	Relay PLC
								M9PV	M9P	●	●	—	—	
								M9BV	M9B	●	●	—	—	
								M9NWV	M9NW	●	●	○	—	
								M9PWV	M9PW	●	●	○	—	
								M9BWV	M9BW	●	●	○	—	
Water resistant (2 colour)	—	—	2 wire	—	—	—	M9BA	—	●	○	—	—		

* Lead wire length 0.5m — (Example) A93
3m L (Example) A93L
5m Z (Example) M9NWZ

* Solid state switches marked with a "○" are manufactured upon receipt of order.

Compact Cylinder/Non-rotating Rod: Double Acting Single Rod **Series CQSK**

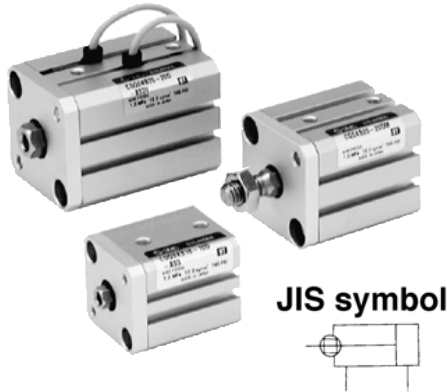

Standard Specifications

Style	Pneumatic(Non-lube)
Operating type	Double acting Single rod
Fluid	Air
Proof pressure	1.5MPa
Max. operating pressure	1.0MPa
Ambient and fluid temperature	Without auto switch -10°C to 70°C (No freezing) With auto switch -10°C to 60°C (No freezing)
Rubber bumper	None
Rod end nut	Female thread
Tolerance of rod end thread	JIS Class 2
Stroke length tolerance	$\begin{matrix} +1.0 \\ 0 \end{matrix}$
Mounting	Through-hole/Both ends tapped
Piston speed	50 to 500mm/s

Minimum Strokes for Auto Switch Mounting

Unit: mm

No. of auto switches	D-A9□, D-M9□WV	D-A9□V	D-M9N	D-M9 β , D-M9□W	D-M9□V	D-M9BA
2	10	10	15*	20*	5	25*
1	10*	5	15	20*	5	25*

* Consult SMC for shorter stroke length than indicated in the table.

Theoretical Force

Unit: N

Bore size (mm)	Rod width across flats (mm)	Action	Piston area (mm ²)	Operating pressure (MPa)		
				0.3	0.5	0.7
12	5.2	IN	90	27	45	63
		OUT	113	34	57	79
16	6.2	IN	168	50	84	117
		OUT	201	60	101	141
20	8.2	IN	256	77	128	179
		OUT	314	94	157	220
25	10.2	IN	401	120	200	281
		OUT	491	147	245	344

⚠ Caution

Snap Ring Installation/Removal

- For installation and removal, use an appropriate pair of pliers (tool for installing a C type snap ring).
- Exercise caution even when using an appropriate pair of pliers because of the possibility of the snap ring becoming detached from the tip of the pliers and flying away, which could injure humans or damage the peripheral equipment. After installing the snap ring, make sure that it is placed securely in the ring groove before supplying air.

Allowable Kinetic Energy

Unit: J

Bore size (mm)	12	16	20	25
Kinetic energy	0.022	0.038	0.055	0.09

Minimum Operating Pressure

Unit: MPa

Bore size (mm)	12	16	20	25
Min. operating pressure	0.07	0.07	0.05	0.05

Rod Non-rotating Specifications

Bore size (mm)	12	16	20	25
Rod non-rotating accuracy	$\pm 1^\circ$		$\pm 0.7^\circ$	

Option

Description	Availability
Rod end male thread	Available for all non-rotating rod models.

Calculation Example) CQSKF20-5DM

- Cylinder weight: CQSKB20-5D.....89g
- Option weight: Rod end male thread.....10g
- Front flange.....142g

Total 241g

Weight/Without Auto Switch

Unit: g

Bore size (mm)	Stroke (mm)									
	5	10	15	20	25	30	35	40	45	50
12	39	46	53	60	67	74	—	—	—	—
16	52	61	69	78	86	95	—	—	—	—
20	89	102	116	129	143	156	170	183	197	211
25	124	141	157	174	190	207	224	240	257	273

Weight/With Auto Switch (Built-in magnet)

Unit: g

Bore size (mm)	Stroke (mm)									
	5	10	15	20	25	30	35	40	45	50
12	47	54	62	69	76	83	—	—	—	—
16	63	71	80	88	97	106	—	—	—	—
20	122	136	149	163	176	190	203	217	230	244
25	168	185	201	218	235	251	268	284	301	317

Option Weights

Unit: g

Bore size (mm)		12	16	20	25
Rod end male thread	Male thread	1.5	3	6	12
	Nut	1	2	4	8
Foot (including bolt)		55	64	158	179
Front flange (including bolt)		58	69	142	178
Rear flange (including bolt)		56	66	137	171
Double clevis (including pin, snap ring, bolt)		34	40	92	127

Series CQSK

Construction

Standard

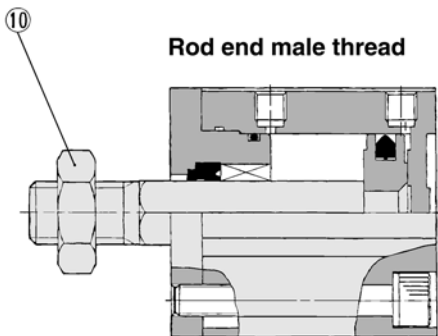
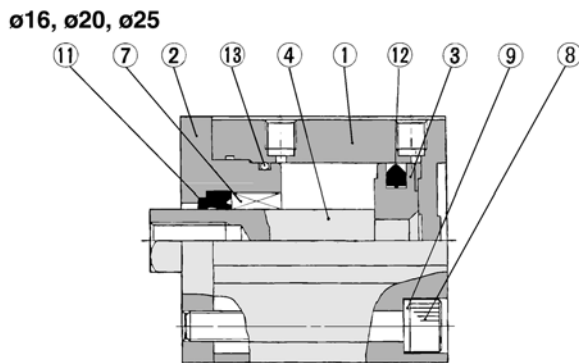
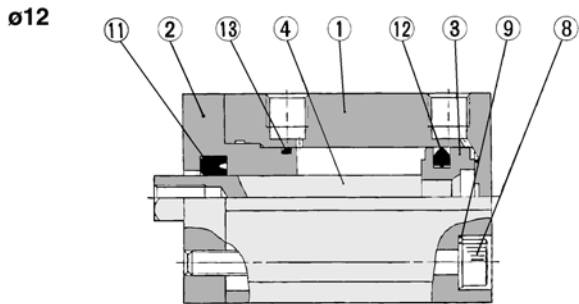

With auto switch (Built-in magnet)

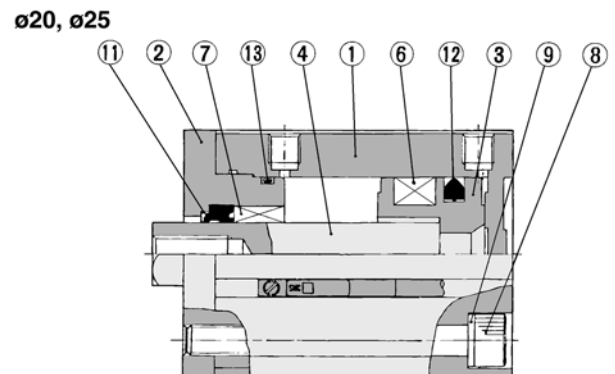
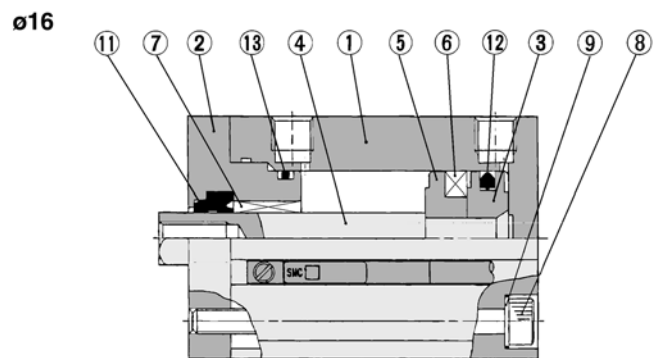
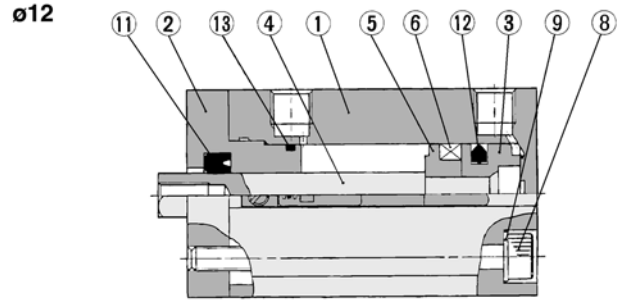

Component Parts

No.	Description	Material	Note
①	Cylinder tube	Aluminum alloy	Hard anodized
②	Rod cover	Aluminum alloy ⁽¹⁾	Anodized
③	Piston	Aluminum alloy	Chromated
④	Piston rod	Stainless steel	
⑤	Switch spacer	Aluminum alloy	Chromated
⑥	Magnet	—	
⑦	Rotating guide	Oil impregnated sintered alloy	ø16, ø20 and ø25
⑧	Hex. socket head cap screw	Alloy steel	Nickel plated
⑨	Plain washer	Rolled steel	Nickel plated
⑩	Rod end nut	Carbon steel	Nickel plated
⑪*	Rod seal	NBR	
⑫*	Piston seal	NBR	
⑬*	Tube gasket	NBR	

Note 1) ø12: Aluminum bearing alloy.

Replacement Parts: Seal Kits

Bore size (mm)	Kit No.	Contents
12	CQSKB12-PS	Kits include items ⑪, ⑫ and ⑬ from the table above.
16	CQSKB16-PS	
20	CQSKB20-PS	
25	CQSKB25-PS	

*Seal kits consist of items ⑪, ⑫ and ⑬ contained in one kit, and can be ordered using the order number for each respective tube bore size.

⚠ Precautions

⚠ Caution

- ① Any kind of operation producing rotation torque to piston rod must be considered. The non-rotating guide would be deformed and the accuracy would be compromised. See the table below for rotation torque allowance.

Allowable rotation torque Nm	ø12	ø16	ø20	ø25
	0.04	0.04	0.2	0.25

- ② Load to piston rod must always be in an axial direction.
 ③ When fixing work piece to piston rod end, completely retract the rod before applying any kind of torque. Prevent torque on the guide bushing by holding the rod stationary with a wrench. Do not apply torque directly to the rod.

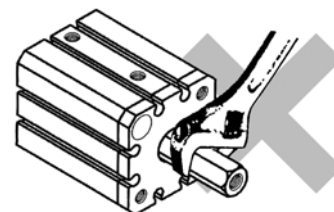

Compact Cylinder/Non-rotating Rod: Double Acting Single Rod **Series CQSK**

Mounting Bolt for CQSK

Special long bolt for through hole mounting is available as an option.

How to Order: Specify the required bolts.

Example) Bolt M3 X 30ℓ 2pcs.

Head side

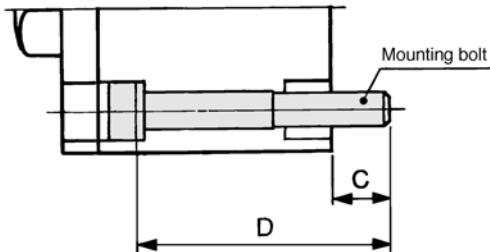

Rod side

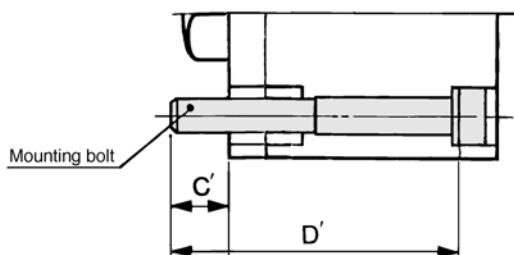

Note) The appropriate plain washer must be used for through-hole.

Model	C	D	Mounting bolt	C'	D'	Mounting bolt
CQSKB12-5D	6.5	25	M3 X 25 ℓ	6.5	30	M3 X 30 ℓ
-10D		30	X 30 ℓ		35	X 35 ℓ
-15D		35	X 35 ℓ		40	X 40 ℓ
-20D		40	X 40 ℓ		45	X 45 ℓ
-25D		45	X 45 ℓ		50	X 50 ℓ
-30D		50	X 50 ℓ		55	X 55 ℓ
CQSKB16-5D	6.5	25	M3 X 25 ℓ	6.5	30	M3 X 30 ℓ
-10D		30	X 30 ℓ		35	X 35 ℓ
-15D		35	X 35 ℓ		40	X 40 ℓ
-20D		40	X 40 ℓ		45	X 45 ℓ
-25D		45	X 45 ℓ		50	X 50 ℓ
-30D		50	X 50 ℓ		55	X 55 ℓ
CQSKB20-5D	6.5	25	M5 X 25 ℓ	6.5	30	M5 X 30 ℓ
-10D		30	X 30 ℓ		35	X 35 ℓ
-15D		35	X 35 ℓ		40	X 40 ℓ
-20D		40	X 40 ℓ		45	X 45 ℓ
-25D		45	X 45 ℓ		50	X 50 ℓ
-30D		50	X 50 ℓ		55	X 55 ℓ
-35D	55	X 55 ℓ	60	X 60 ℓ		
-40D	60	X 60 ℓ	65	X 65 ℓ		
-45D	65	X 65 ℓ	70	X 70 ℓ		
-50D	70	X 70 ℓ	75	X 75 ℓ		
CQSKB25-5D	8.5	30	M5 X 30 ℓ	8.5	35	M5 X 35 ℓ
-10D		35	X 35 ℓ		40	X 40 ℓ
-15D		40	X 40 ℓ		45	X 45 ℓ
-20D		45	X 45 ℓ		50	X 50 ℓ
-25D		50	X 50 ℓ		55	X 55 ℓ
-30D		55	X 55 ℓ		60	X 60 ℓ
-35D		60	X 60 ℓ		65	X 65 ℓ
-40D		65	X 65 ℓ		70	X 70 ℓ
-45D		70	X 70 ℓ		75	X 75 ℓ
-50D		75	X 75 ℓ		80	X 80 ℓ

Mounting Bolt for CDQSK

Special long bolt for through hole mounting is available as an option.

How to Order: Specify the required bolts.

Example) Bolt M3 X 35ℓ 2pcs.

Head side

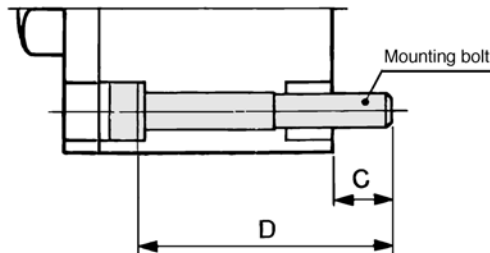

Rod side

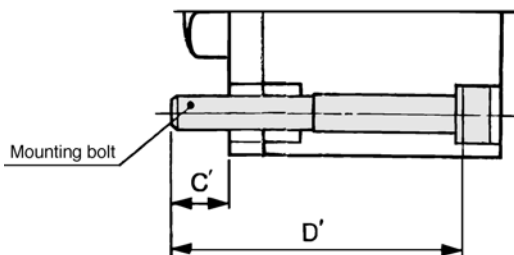

Note) The appropriate plain washer must be used for through-hole.

Model	C	D	Mounting bolt	C'	D'	Mounting bolt
CDQSKB12-5D	6.5	30	M3 X 30 ℓ	6.5	35	M3 X 35 ℓ
-10D		35	X 35 ℓ		40	X 40 ℓ
-15D		40	X 40 ℓ		45	X 45 ℓ
-20D		45	X 45 ℓ		50	X 50 ℓ
-25D		50	X 50 ℓ		55	X 55 ℓ
-30D		55	X 55 ℓ		60	X 60 ℓ
CDQSKB16-5D	6.5	30	M3 X 30 ℓ	6.5	35	M3 X 35 ℓ
-10D		35	X 35 ℓ		40	X 40 ℓ
-15D		40	X 40 ℓ		45	X 45 ℓ
-20D		45	X 45 ℓ		50	X 50 ℓ
-25D		50	X 50 ℓ		55	X 55 ℓ
-30D		55	X 55 ℓ		60	X 60 ℓ
CDQSKB20-5D	6.5	35	M5 X 35 ℓ	6.5	40	M5 X 40 ℓ
-10D		40	X 40 ℓ		45	X 45 ℓ
-15D		45	X 45 ℓ		50	X 50 ℓ
-20D		50	X 50 ℓ		55	X 55 ℓ
-25D		55	X 55 ℓ		60	X 60 ℓ
-30D		60	X 60 ℓ		65	X 65 ℓ
-35D	65	X 65 ℓ	70	X 70 ℓ		
-40D	70	X 70 ℓ	75	X 75 ℓ		
-45D	75	X 75 ℓ	80	X 80 ℓ		
-50D	80	X 80 ℓ	85	X 85 ℓ		
CDQSKB25-5D	8.5	40	M5 X 40 ℓ	8.5	45	M5 X 45 ℓ
-10D		45	X 45 ℓ		50	X 50 ℓ
-15D		50	X 50 ℓ		55	X 55 ℓ
-20D		55	X 55 ℓ		60	X 60 ℓ
-25D		60	X 60 ℓ		65	X 65 ℓ
-30D		65	X 65 ℓ		70	X 70 ℓ
-35D		70	X 70 ℓ		75	X 75 ℓ
-40D		75	X 75 ℓ		80	X 80 ℓ
-45D		80	X 80 ℓ		85	X 85 ℓ
-50D		85	X 85 ℓ		90	X 90 ℓ

Series CQSK

Dimensions/ø12 to ø25



*Refer to P.1-408 for mounting position and height of auto switch.

Basic (Through-hole/Both ends tapped)/CQSK, CDQSK

ø12

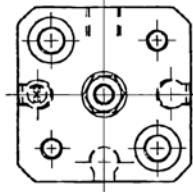

ø16

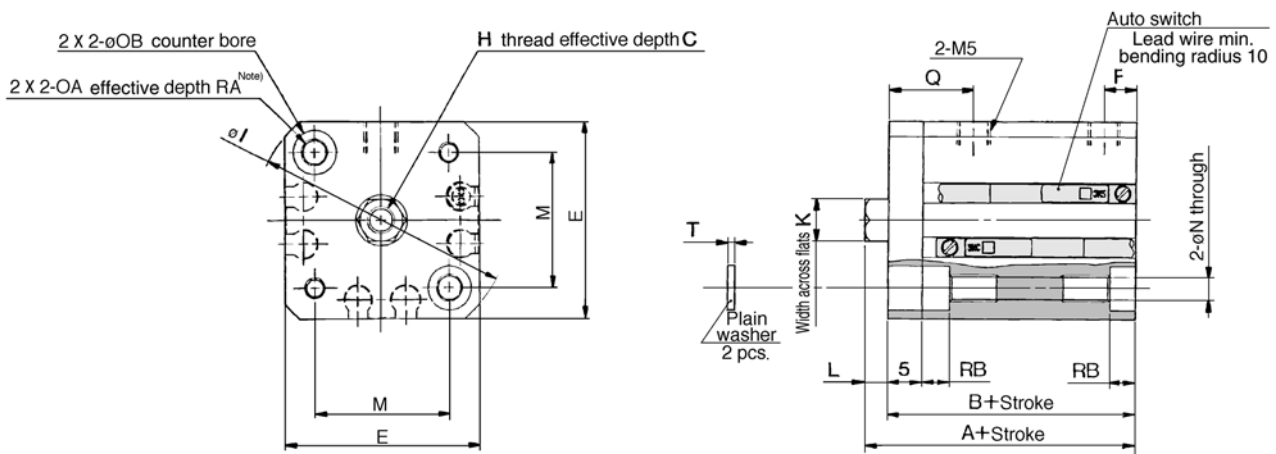

ø20, ø25

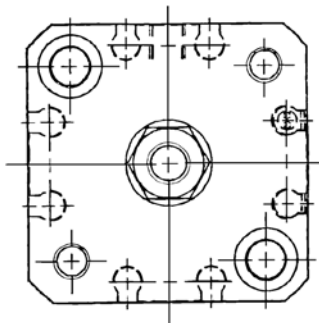

Rod end male thread

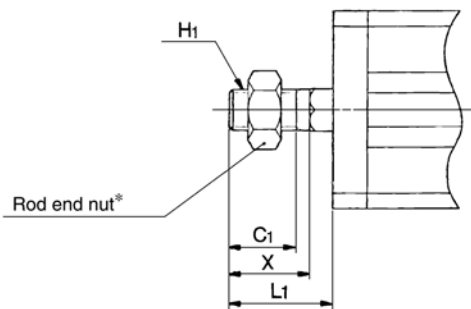

			L1	X
			14	10.5
			15.5	12
20	12	M8	18.5	14
25	15	M10 X 1.25	22.5	17.5

Basic

(All dimension are common except "A" and "B").

Bore (mm)	Stroke range (mm)	W/o auto switch		With auto switch		C	E	F	H	I	K	L	M	N	OA	OB	Q	RA	RB	T
		A	B	A	B															
12	5 to 30	25.5	22	30.5	27	6	25	5	M3	32	5.2	3.5	15.5	3.5	M4	6.5	12.5	7	4	0.5
16	5 to 30	25.5	22	30.5	27	8	29	5	M4	38	6.2	3.5	20	3.5	M4	6.5	12.5	7	4	0.5
20	5 to 50	29	24.5	39	34.5	7	36	5.5	M5	47	8.2	4.5	25.5	5.4	M6	9	14	10	7	1
25	5 to 50	32.5	27.5	42.5	37.5	12	40	5.5	M6	52	10.2	5	28	5.4	M6	9	16	10	7	1

Note) For the following bore/stroke sizes, through hole is threaded over the entire length.

Basic: ø12 and ø16; 5 stroke, ø20; 5 to 15 stroke, ø25; 5 and 10 stroke.

Note) With auto switch (Built-in magnet): ø20; 5 stroke

*Refer to p.1-442 for detail of the rod end nut and mounting brackets.

Compact Cylinder/Non-rotating Rod: Double Acting Single Rod **Series CQSK**

Foot/CQSKL, CDQSKL

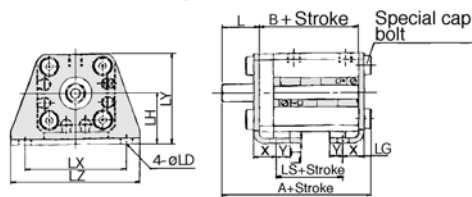

(All dimensions are common between standard stroke and long stroke except "A", "B" and "LS".)

No auto switch		With auto switch			L	L ₁	LD	LG	LH	LT	LX	LY	LZ	X	Y
B	LS	A	B	LS											
22	10	45.3	27	15	13.5	24	4.5	2.8	17	2	34	29.5	44	8	4.5
22	10	45.3	27	15	13.5	25.5	4.5	2.8	19	2	38	33.5	48	8	5
4.5	12.5	56.2	34.5	22.5	14.5	28.5	6.6	4	24	3.2	48	42	62	9.2	5.8
7.5	12.5	59.7	37.5	22.5	15	32.5	6.6	4	26	3.2	52	46	66	10.7	5.8

Rod end nut

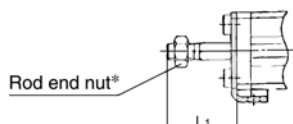

Front flange/CQSKF, CDQSKF

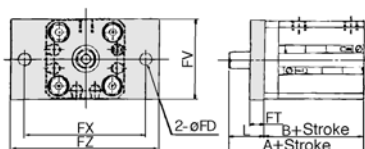

(All dimensions are common between standard stroke and long stroke except "A" and "B".)

No auto switch		With auto switch			FD	FT	FV	FX	FZ	L	L ₁
B	A	B									
5	22	40.5	27	4.5	5.5	25	45	55	13.5	24	
5	22	40.5	27	4.5	5.5	30	45	55	13.5	25.5	
9	24.5	49	34.5	6.6	8	39	48	60	14.5	28.5	
5	27.5	52.5	37.5	6.6	8	42	52	64	15	32.5	

Rod end nut

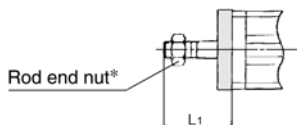

Rear flange/CQSKG, CDQSKG

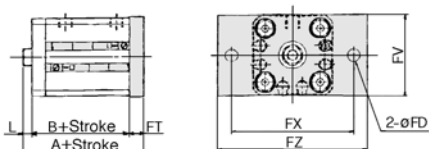

(All dimensions are common between standard stroke and long stroke except "A", and "B".)

No auto switch		With auto switch			FD	FT	FV	FX	FZ	L	L ₁
B	A	B									
1	22	36	27	4.5	5.5	25	45	55	3.5	14	
1	22	36	27	4.5	5.5	30	45	55	3.5	15.5	
7	24.5	47	34.5	6.6	8	39	48	60	4.5	18.5	
5	27.5	50.5	37.5	6.6	8	42	52	64	5	22.5	

Rod end nut

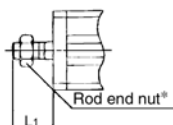

Double clevis/CQSKD, CDQSKD

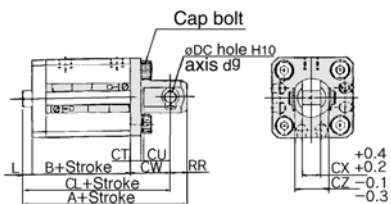

(All dimensions are common between standard stroke and long stroke except "A", "B" and "CL".)

No auto switch		With auto switch			CD	CT	CU	CW	CX	CZ	L	L ₁	RR	
B	CL	A	B	CL										
5	22	39.5	50.5	27	44.5	5	4	7	14	5	10	3.5	14	6
5	22	40.5	51.5	27	45.5	5	4	10	15	6.5	12	3.5	15.5	6
5	24.5	47	66	34.5	57	8	5	12	18	8	16	4.5	18.5	9
5	27.5	52.5	72.5	37.5	62.5	10	5	14	20	10	20	5	22.5	10

the rod end nut and mounting brackets.

Rod end nut

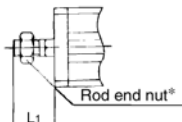

Compact Cylinder/Anti-lateral Load

Series CQS□S

ø12, ø16, ø20, ø25

How to Order

Standard CQS B S 20-30 D C

With auto switch CDQS B S 20-30 D C A90 S

With auto switch
(Built-in magnet)

Mounting style

B	Through-hole/Both ends tapped (Standard)
L	Foot
F	Front flange
G	Rear flange
D	Double clevis

Style

S	Anti-lateral load
---	-------------------

Bore size

12	12mm
16	16mm
20	20mm
25	25mm

Cylinder stroke (mm)

Option

C	Rod end female thread with rubber bumper
CM	Rod end male thread with rubber bumper

Auto switch

—	Without auto switch (Built-in magnet)
---	---------------------------------------

* Refer to table below for auto switch model no.

Number of auto switches

—	2
S	1
n	n

Action

D	Double acting
---	---------------

Standard stroke

Bore (mm)	Standard stroke (mm)
12, 16	5, 10, 15, 20, 25, 30
20, 25	5, 10, 15, 20, 25, 30, 35, 40, 45, 50

Intermediate strokes at 1mm intervals are available by using spacers with standard stroke cylinders. Intermediate stroke model has the same body length as standard model whose stroke is longer than that of the intermediate model.
Example) CQSBS25-47DC: CQSBS25-50DC with 3mm width spacer inside.

Mounting Bracket Part No.

Bore size (mm)	Foot ⁽¹⁾	Flange	Double clevis
12	CQS-L012	CQS-F012	CQS-D012
16	CQS-L016	CQS-F016	CQS-D016
20	CQS-L020	CQS-F020	CQS-D020
25	CQS-L025	CQS-F025	CQS-D025

Note 1) 2 pieces per cylinder should be ordered.
Note 2) Each package contains the following parts.
Foot or Flange style: Body mounting bolt
Double clevis style: Clevis pin, snap ring retainer, body mounting bolt

Applicable Auto Switches

Style	Special function	Electrical entry	Indicator	Wiring (Output)	Load voltage			Auto switch model		Lead wire(m)*			Applicable load	
					DC		AC	Perpendicular	In-line	0.5 (-)	3 (L)	5 (Z)		
					24V	5V 12V 100V or less	100V	A90V	A90	●	●	—		IC
Reed switch	—	Grommet	No	2 wire	24V	5V 12V 100V or less	100V	A93V	A93	●	●	—	—	Relay PLC
								A96V	A96	●	●	—	IC	
Solid state switch	—	Grommet	Yes	3 wire (NPN)	24V	12V	—	M9NV	M9N	●	●	—	Relay PLC	
				3 wire (PNP)				M9PV	M9P	●	●	—		
				2 wire				M9BV	M9B	●	●	—		
				3 wire (NPN)				M9NWV	M9NW	●	●	○		—
				3 wire (PNP)				M9PWV	M9PW	●	●	○		—
				2 wire				M9BWV	M9BW	●	●	○		—
				Water resistant (2 colour indication)				—	M9BA	—	●	○		—

* Lead wire length 0.5m — (Example) A93
3m L (Example) A93L
5m Z (Example) M9NWZ
* Solid state switches marked with a "○" are manufactured upon receipt of order.

Compact Cylinder/Anti-lateral Load Series CQS□S



Standard Specifications

Style	Pneumatic(Non-lube)
Action	Double acting Single rod
Fluid	Air
Proof pressure	1.5MPa
Max. operating pressure	1.0MPa
Ambient and fluid temperature	Without auto switch -10°C to 70°C (No freezing) With auto switch -10°C to 60°C (No freezing)
Rubber bumper	Standard equipment
Rod end thread	Female thread
Tolerance of rod end thread	JIS Class 2
Allowable tolerance of stroke length	$\begin{matrix} +1.0 \\ 0 \end{matrix}$
Mounting	Through-hole/Both ends tapped
Piston speed	50 to 500mm/s

Minimum Strokes for Auto Switch Mounting

Unit: mm

No. of auto switches	D-A9□, D-M9□WV	D-A9□V	D-M9N	D-M9 ^B , D-M9□W	D-M9□V	D-M9BA
2	10	10	15*	20*	5	25*
1	10*	5	15*	20*	5	25*

*Consult SMC for shorter stroke length than indicated in the table.

JIS symbol

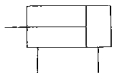

Theoretical Force

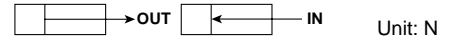

Unit: N

Bore size (mm)	Rod diameter (mm)	Action	Piston area (mm ²)	Operating pressure (MPa)		
				0.3	0.5	0.7
12	6	IN	84.8	25	42	59
		OUT	113	34	57	79
16	8	IN	151	45	75	106
		OUT	201	60	101	141
20	10	IN	236	71	118	165
		OUT	314	94	157	220
25	12	IN	378	113	189	264
		OUT	491	147	245	344

Allowable Kinetic Energy

Unit: J

Bore size (mm)	12	16	20	25
Kinetic energy	0.043	0.075	0.11	0.18

Minimum Operating Pressure

Unit: MPa

Bore size (mm)	12	16	20	25
Min. operating pressure	0.07	0.07	0.05	0.05

Option

Description	Application
Rod end male thread	Available for double acting single rod models.

Calculation Example: CQSDS20-20DCM

•Cylinder weight: CQSBS20-20DC..... 114g
•Option weight : Rod end male thread..... 10g
: Double clevis 92g

Total 216g

Weight/Without Auto Switch

Unit: g

Bore size (mm)	Stroke (mm)									
	5	10	15	20	25	30	35	40	45	50
12	37	43	50	57	63	70	-	-	-	-
16	49	57	66	74	83	92	-	-	-	-
20	75	88	101	114	127	140	153	165	178	191
25	109	125	140	156	172	188	204	220	236	252

Weight/With Auto Switch (Built-in magnet)

Unit: g

Bore size (mm)	Stroke (mm)									
	5	10	15	20	25	30	35	40	45	50
12	45	51	58	65	71	78	-	-	-	-
16	59	67	76	85	94	103	-	-	-	-
20	106	119	132	145	157	170	183	195	208	221
25	151	167	183	199	215	231	246	262	278	294

Option Weights

Unit: g

Bore size (mm)		12	16	20	25
Rod end male thread	Male thread	1.5	3	6	12
	Nut	1	2	4	8
Foot (including bolt)		55	65	159	181
Front flange (including bolt)		58	70	143	180
Rear flange (including bolt)		56	66	137	171
Double clevis (including pin, snap ring, bolt)		34	40	92	127

Series CQS□S

Construction

Basic

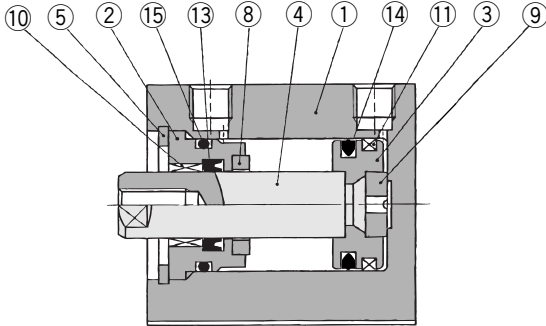

Rod end male thread

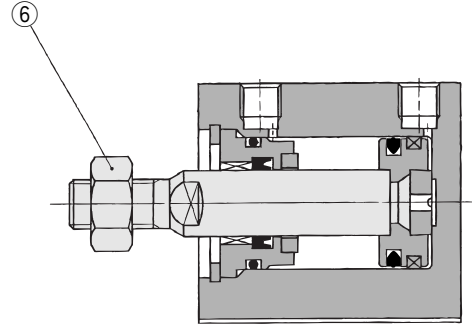

With auto switch (Built-in magnet)

ø12, ø16

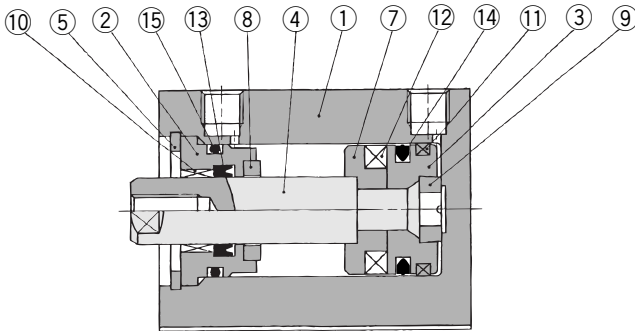

ø20, ø25

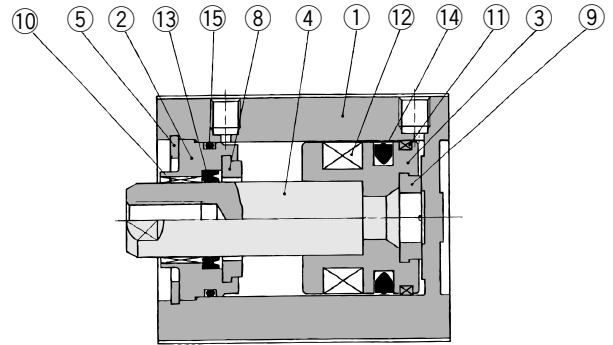

Components Parts

No.	Description	Material	Note
①	Cylinder tube	Aluminum alloy	Hard anodized
②	Collar	Aluminum alloy	Anodized
③	Piston	Aluminum alloy	Chromated
④	Piston rod	Stainless steel	
⑤	Snap ring	Carbon tool steel	Phosphate coating
⑥	Rod end nut	Carbon steel	Nickel plated
⑦	Awitch spacer	Aluminum alloy	Chromated
⑧	Bumper A	Urethane	
⑨	Bumper B	Urethane	
⑩	Bushing	Oil impregnated sintered alloy	
⑪	Wearing	Resin	
⑫	Magnet	—	
⑬*	Rod seal	NBR	
⑭*	Piston seal	NBR	
⑮*	Tube gasket	NBR	

Replacement Parts: Seal Kits

Bore size (mm)	Kit No.	Contents
12	CQSB12-PS	Kits include items ⑬, ⑭ and ⑮ from the table above.
16	CQSB16-PS	
20	CQSB20-PS	
25	CQSB25-PS	

*Seal kits consist of items ⑬, ⑭ and ⑮ contained in one kit, and can be ordered using the order number for each respective tube bore size.

Mounting Bolt for CQSBS

Special long bolt for through hole mounting is available as an option.

How to Order: Specify the required bolts.
Example) Bolt M3 X 30ℓ 4pcs.

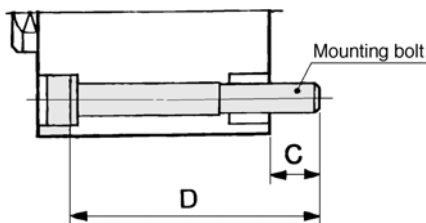

Model	C	D	Mounting bolt
CQSBS12 - 5DC	6.5	30	M3 X 30ℓ
- 10DC		35	X 35ℓ
- 15DC		40	X 40ℓ
- 20DC		45	X 45ℓ
- 25DC		50	X 50ℓ
- 30DC		55	X 55ℓ
CQSBS16 - 5DC	6.5	30	M3 X 30ℓ
- 10DC		35	X 35ℓ
- 15DC		40	X 40ℓ
- 20DC		45	X 45ℓ
- 25DC		50	X 50ℓ
- 30DC		55	X 55ℓ
CQSBS20 - 5DC	6.5	30	M5 X 30ℓ
- 10DC		35	X 35ℓ
- 15DC		40	X 40ℓ
- 20DC		45	X 45ℓ
- 25DC		50	X 50ℓ

Model	C	D	Mounting bolt
CQSBS20 - 25DC	6.5	50	M5 X 50ℓ
- 30DC		55	X 55ℓ
- 35DC		60	X 60ℓ
- 40DC		65	X 65ℓ
- 45DC		70	X 70ℓ
- 50DC		75	X 75ℓ
CQSBS25 - 5DC	8.5	35	M5 X 35ℓ
- 10DC		40	X 40ℓ
- 15DC		45	X 45ℓ
- 20DC		50	X 50ℓ
- 25DC		55	X 55ℓ
- 30DC		60	X 60ℓ
- 35DC		65	X 65ℓ
- 40DC		70	X 70ℓ
- 45DC		75	X 75ℓ
- 50DC		80	X 80ℓ



Note) The appropriate plain washer must be used for through-hole.

Mounting Bolt for CDQSBS/With Auto Switch

Special long bolt for through hole mounting is available as an option.

How to Order: Specify the required bolts.
Example) Bolt M3 X 35ℓ 4pcs.

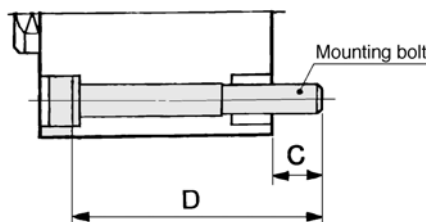

Model	C	D	Mounting bolt
CDQSBS12 - 5DC	6.5	35	M3 X 35ℓ
- 10DC		40	X 40ℓ
- 15DC		45	X 45ℓ
- 20DC		50	X 50ℓ
- 25DC		55	X 55ℓ
- 30DC		60	X 60ℓ
CDQSBS16 - 5DC	6.5	35	M3 X 35ℓ
- 10DC		40	X 40ℓ
- 15DC		45	X 45ℓ
- 20DC		50	X 50ℓ
- 25DC		55	X 55ℓ
- 30DC		60	X 60ℓ
CDQSBS20 - 5DC	6.5	40	M5 X 40ℓ
- 10DC		45	X 45ℓ
- 15DC		50	X 50ℓ
- 20DC		55	X 55ℓ
- 25DC		60	X 60ℓ

Model	C	D	Mounting bolt
CDQSBS20 - 25DC	6.5	60	M5 X 60ℓ
- 30DC		65	X 65ℓ
- 35DC		70	X 70ℓ
- 40DC		75	X 75ℓ
- 45DC		80	X 80ℓ
- 50DC		85	X 85ℓ
CDQSBS25 - 5DC	8.5	45	M5 X 45ℓ
- 10DC		50	X 50ℓ
- 15DC		55	X 55ℓ
- 20DC		60	X 60ℓ
- 25DC		65	X 65ℓ
- 30DC		70	X 70ℓ
- 35DC		75	X 75ℓ
- 40DC		80	X 80ℓ
- 45DC		85	X 85ℓ
- 50DC		90	X 90ℓ



Note) The appropriate plain washer must be used for through-hole.

Rod End Allowable Lateral Load

- All loads to piston rod must be applied in axial direction only.
- Unavoidable side loads to rod end must be less than the values in the figures.
- Cylinder installation requires accurate alignment.
- Adoption of guide mechanism is strongly recommended for the case when CQS is used as stopper to prevent non-rotating piston rod from side forces.

Note 1) Right figure: Rod end female thread.

Note 2) Lateral load allowance varies depending upon rod end shape dimensions or load value (distance to the centre of the gravity of load.) Consult SMC.



Without auto switch

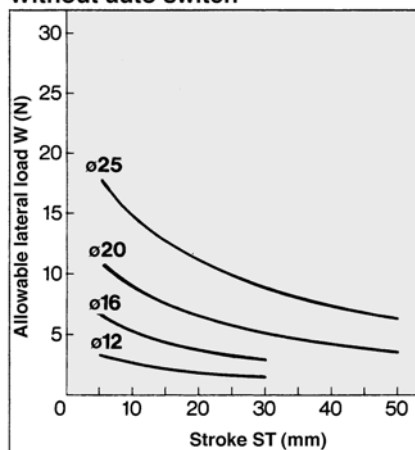

With auto switch

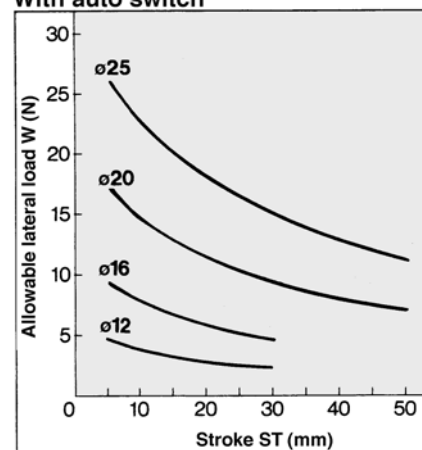

Series CQS□S

Dimensions/ø12 to ø25

Basic (Through-hole/Both ends tapped)/CQSBS, CDQSBS

ø12

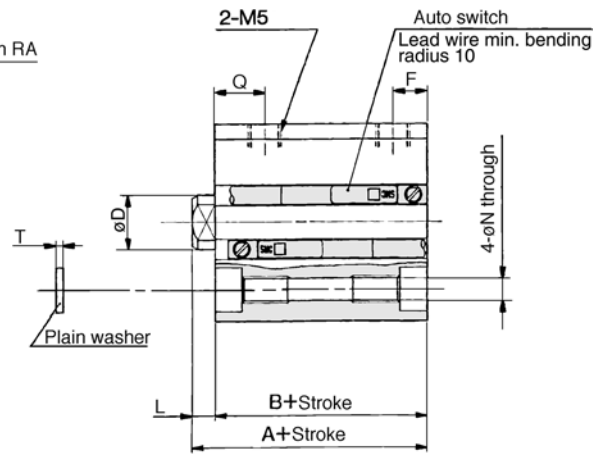
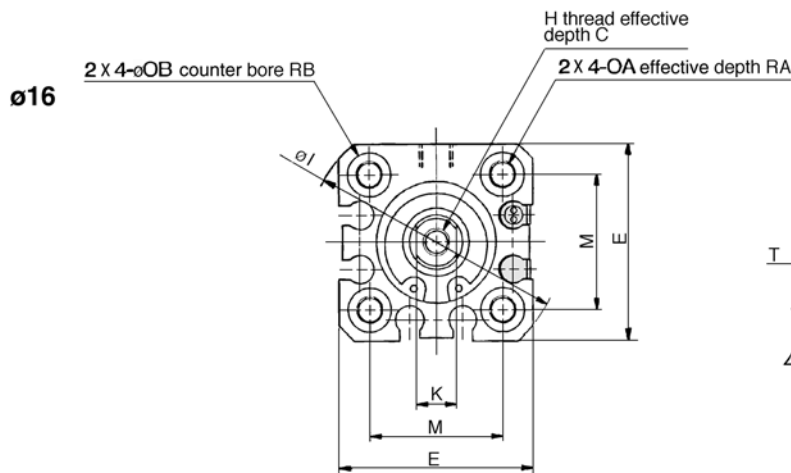
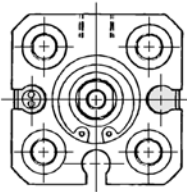

ø20, ø25

Rod end male thread

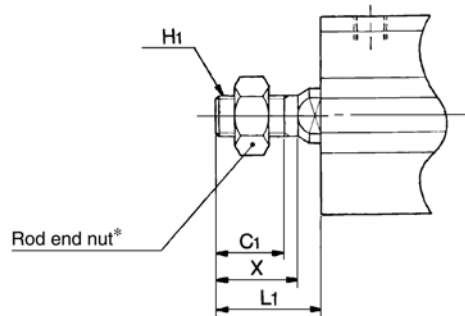
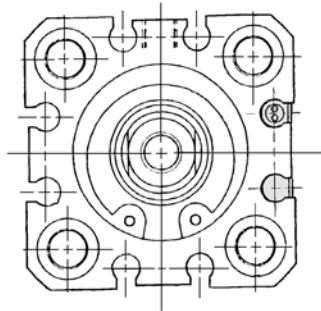

Bore (mm)	C ₁	H ₁	L ₁	X
12	9	M5	14	10.5
16	10	M6	15.5	12
20	12	M8	18.5	14
25	15	M10 X 1.25	22.5	17.5

Basic

(All dimensions are common between standard stroke and long stroke except "A" and "B".)

Bore (mm)	Stroke range (mm)	W/o auto switch		With auto switch		C	D	E	F	H	I	K	L	M	N	OA	OB	Q	RA	RB	T
		A	B	A	B																
12	5 to 30	25.5	22	30.5	27	6	6	25	5	M3	32	5	3.5	15.5	3.5	M4	6.5	7.5	7	4	0.5
16	5 to 30	25.5	22	30.5	27	8	8	29	5	M4	38	6	3.5	20	3.5	M4	6.5	7.5	7	4	0.5
20	5 to 50	29	24.5	39	34.5	7	10	36	5.5	M5	47	8	4.5	25.5	5.4	M6	9	9	10	7	1
25	5 to 50	32.5	27.5	42.5	37.5	12	12	40	5.5	M6	52	10	5	28	5.4	M6	9	11	10	7	1

Note) For the following bore/stroke sizes, through-hole is threaded over the entire length.

ø20; 5 to 10 stroke, ø25; 5 stroke

*Refer to p.1-442 for details of the rod end nut and mounting brackets.

Compact Cylinder/Anti-lateral Load Series CQS□S

Foot/CQSLS, CQDLS

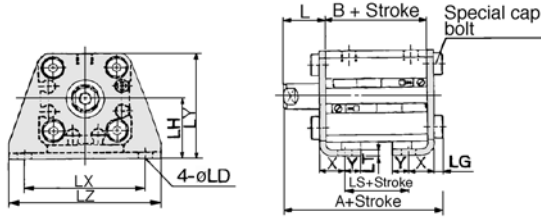

Rod end male thread

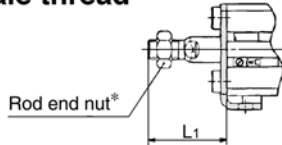

Front flange/CQSFS, CDQSFS

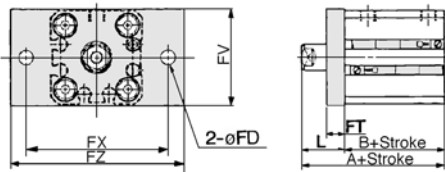

Rod end male thread

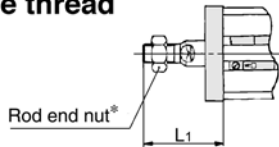

Rear flange/CQSGS, CDQSGS

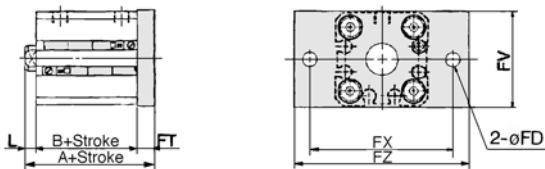

Rod end male thread

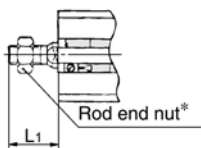

Double clevis/CQSDS, CDQSDS

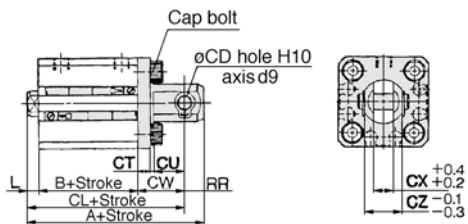

Rod end male thread

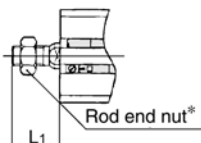

Foot

(All dimensions are common between standard stroke and long stroke except "A", "B" and "LS".)

Bore (mm)	Stroke range (mm)	Without auto switch			With auto switch		
		A	B	LS	A	B	LS
12	5 to 30	40.3	22	10	45.3	27	15
16	5 to 30	40.3	22	10	45.3	27	15
20	5 to 50	46.2	24.5	12.5	56.2	34.5	22.5
25	5 to 50	49.7	27.5	12.5	59.7	37.5	22.5

Bore (mm)	L	L ₁	LD	LG	LH	LT	LX	LY	LZ	X	Y
12	13.5	24	4.5	2.8	17	2	34	29.5	44	8	4.5
16	13.5	25.5	4.5	2.8	19	2	38	33.5	48	8	5
20	14.5	28.5	6.6	4	24	3.2	48	42	62	9.2	5.8
25	15	32.5	6.6	4	26	3.2	52	46	66	10.7	5.8

Front flange

(All dimensions are common between standard stroke and long stroke except "A" and "B".)

Bore (mm)	Stroke range (mm)	Without auto switch		With auto switch	
		A	B	A	B
12	5 to 30	35.5	22	40.5	27
16	5 to 30	35.5	22	40.5	27
20	5 to 50	39	24.5	49	34.5
25	5 to 50	42.5	27.5	52.5	37.5

Bore (mm)	FD	FT	FV	FX	FZ	L	L ₁
12	4.5	5.5	25	45	55	13.5	24
16	4.5	5.5	30	45	55	13.5	25.5
20	6.6	8	39	48	60	14.5	28.5
25	6.6	8	42	52	64	15	32.5

Rear flange

(All dimensions are common between standard stroke and long stroke except "A" and "B".)

Bore (mm)	Stroke range (mm)	Without auto switch		With auto switch	
		A	B	A	B
12	5 to 30	31	22	36	27
16	5 to 30	31	22	36	27
20	5 to 50	37	24.5	47	34.5
25	5 to 50	40.5	27.5	50.5	37.5

Bore (mm)	FD	FT	FV	FX	FZ	L	L ₁
12	4.5	5.5	25	45	55	3.5	14
16	4.5	5.5	30	45	55	3.5	15.5
20	6.6	8	39	48	60	4.5	18.5
25	6.6	8	42	52	64	5	22.5

Double clevis

(All dimensions are common between standard stroke and long stroke except "A", "B" and "CL".)

Bore (mm)	Stroke range (mm)	Without auto switch			With auto switch		
		A	B	CL	A	B	CL
12	5 to 30	45.5	22	39.5	50.5	27	44.5
16	5 to 30	46.5	22	40.5	51.5	27	45.5
20	5 to 50	56	24.5	47	66	34.5	57
25	5 to 50	62.5	27.5	52.5	72.5	37.5	62.5

Bore (mm)	CD	CT	CU	CW	CX	CZ	L	L ₁	RR
12	5	4	7	14	5	10	3.5	14	6
16	5	4	10	15	6.5	12	3.5	15.5	6
20	8	5	12	18	8	16	4.5	18.5	9
25	10	5	14	20	10	20	5	22.5	10

*Refer to p.1-442 detail of the rod end nut and mounting brackets.

Series CQS Auto Switch Specifications

Refer to p.6-15 of details of auto switch.



Applicable auto switch

Applicable bore size	Auto switch model		Electrical entry	
ø12, ø16 ø20, ø25	Reed switch	D-A90	Grommet	2 wire, In-line
		D-A93		3 wire, In-line
		D-A96		2 wire, Perpendicular
		D-A90V		3 wire, Perpendicular
		D-A93V		3 wire, NPN, In-line
		D-A96V		3 wire, PNP, In-line
	Solid state switch	D-M9N	Grommet	2 wire, In-line
		D-M9P		3 wire, NPN, In-line (2 colour)
		D-M9B		3 wire, PNP, In-line (2 colour)
		D-M9NW		2 wire, In-line(2 colour)
		D-M9PW		3 wire, NPN, Perpendicular
		D-M9BW		3 wire, Water resistant
		D-M9NV		2 wire, Perpendicular
		D-M9PV		3 wire, NPN, Perpendicular(2 colour)
		D-M9BV		3 wire, Water resistant(2 colour)
		D-M9NWV		2 wire, Perpendicular(2 colour)
		D-M9PWV		3 wire, Water resistant(2 colour)
		D-M9BWV		2 wire, Perpendicular(2 colour)
		D-M9BAL		2 wire, In-line(2 colour), Water resistant

⚠ Precautions

- If the cylinder is used in an application in which a magnetic material is placed in close contact around the cylinder as shown in the diagram on the right (including cases in which even one of the sides is in close contact) the operation of auto switches could become unstable. Therefore, check with SMC for this type of application.

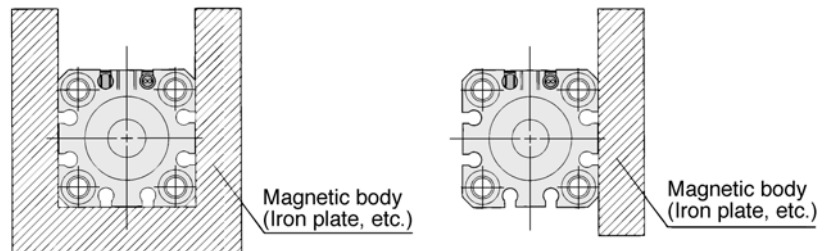

Series CQS

Auto Switch Mounting Position and Mounting Height

(Double acting single rod, Single acting single rod/spring return, spring extend, Long stroke, Anti-lateral load, Double acting double rod)

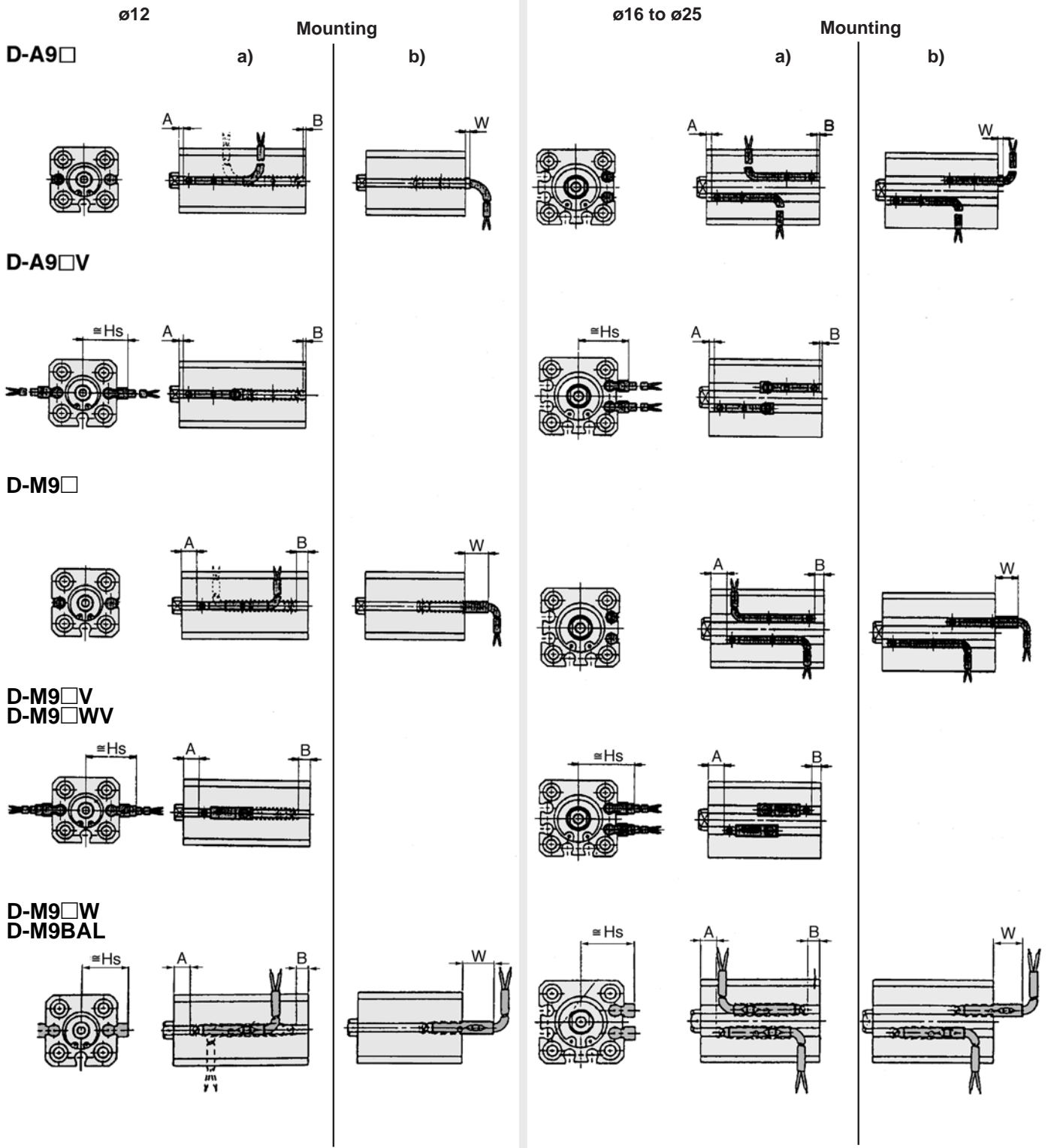

Auto Switch Mounting Position and Mounting Height

Auto switch model No.	D-A9□				D-A9□V			D-M9N/D-M9B D-M9P/D-M9□W			D-M9□V/D-M9□WV		
Symbol	A	B	W	A	B	Hs	A	B	W	A	B	W	
Double acting: single rod, Single acting: single rod/spring return, spring extend													
Bore size (mm)	12	1.5 (2.5)	0	1.5[4] (2.5[5])	1.5 (2.5)	0	17	5.5	4.5	5.5	5.5 (6.5)	4.5 (3.5)	19
	16	2	0	2[4.5]	2	0	19	6	4	6	6	4	21
	20	6	3.5	-1.5[1]	6	3.5	22.5	10	7.5	2.5	10	7.5	24.5
	25	7	5.5	-3.5[-1]	7	5.5	24.5	11	9.5	0.5	11	9.5	26.5
Long stroke													
Bore size (mm)	12	5	7	-5[-2.5]	5	7	17	9	11	-1	9	11	19.5
	16	5.5	6	-4.5[-2]	5.5	6	19	9.5	10.5	-0.5	9.5	10.5	21.5
	20	9	11.5	-10[-7.5]	9	11.5	22.5	13	16	-6	13	16	25
	25	10	13.5	-12[-9.5]	10	13.5	24.5	14	18	-8	14	18	27
Anti-lateral load													
Bore size (mm)	12	6	0.5	1[3.5]	6	0.5	17	10	5	5	10	5	19.5
	16	5.5	1	0.5[3]	5.5	1	19	9.5	5.5	4.5	9.5	5.5	21.5
	20	9	5	-3.5[-1]	9	5	22.5	13	9.5	0.5	13	9.5	25
	25	10	7	-5.5[-3]	10	7	24.5	14	11.5	-1.5	14	11.5	27
Double acting: double rod													
Bore size (mm)	12	1.5	5.5	3.5[6]	1.5	5.5	17	5.5	9.5	0.5	5.5	9.5	19.5
	16	2	5	3[5.5]	2	5	19	6	9	1	6	9	21.5
	20	6	10	8[10.5]	6	10	22.5	10	14	-4	10	14	25
	25	7	12	10[12.5]	7	12	24.5	11	16	-6	11	16	27

Auto switch model No.	D-M9BAL				
Symbol	A	B	W	Hs	
Double acting: single rod, Single acting: single rod/spring return, spring extend					
Bore size (mm)	12	4.5	3.5	14.5	16.5
	16	5	3	15	18.5
	20	9	6.5	11.5	22
	25	10	8.5	9.5	24
Long stroke					
Bore size (mm)	12	8	10	8	16.5
	16	8.5	9.5	8.5	18.5
	20	12	15	3	22
	25	13	17	1	24
Anti-lateral load					
Bore size (mm)	12	9	4	14	16.5
	16	8.5	4.5	13.5	18.5
	20	12	8.5	9.5	22
	25	13	10.5	7.5	24
Double acting: double rod					
Bore size (mm)	12	4.5	8.5	9.5	16.5
	16	5	8	10	18.5
	20	9	13	5	22
	25	10	15	3	24



Note 1) The product is shipped out of the factory in installation state "a)". To change the electrical entry direction of the switch on the head, refer to installation state "b)".

Note 2) In the W column in the table, if the indicated dimension is a negative number, the auto switch must be installed inward from the end of the cylinder body.

Note 3) The D-M9N, M9B, M9P, M9□W, and M9BAL cannot be installed on the single acting: single rod style.

Series CQS

Auto Switch Mounting Position and Mounting Height (Non-rotating rod)

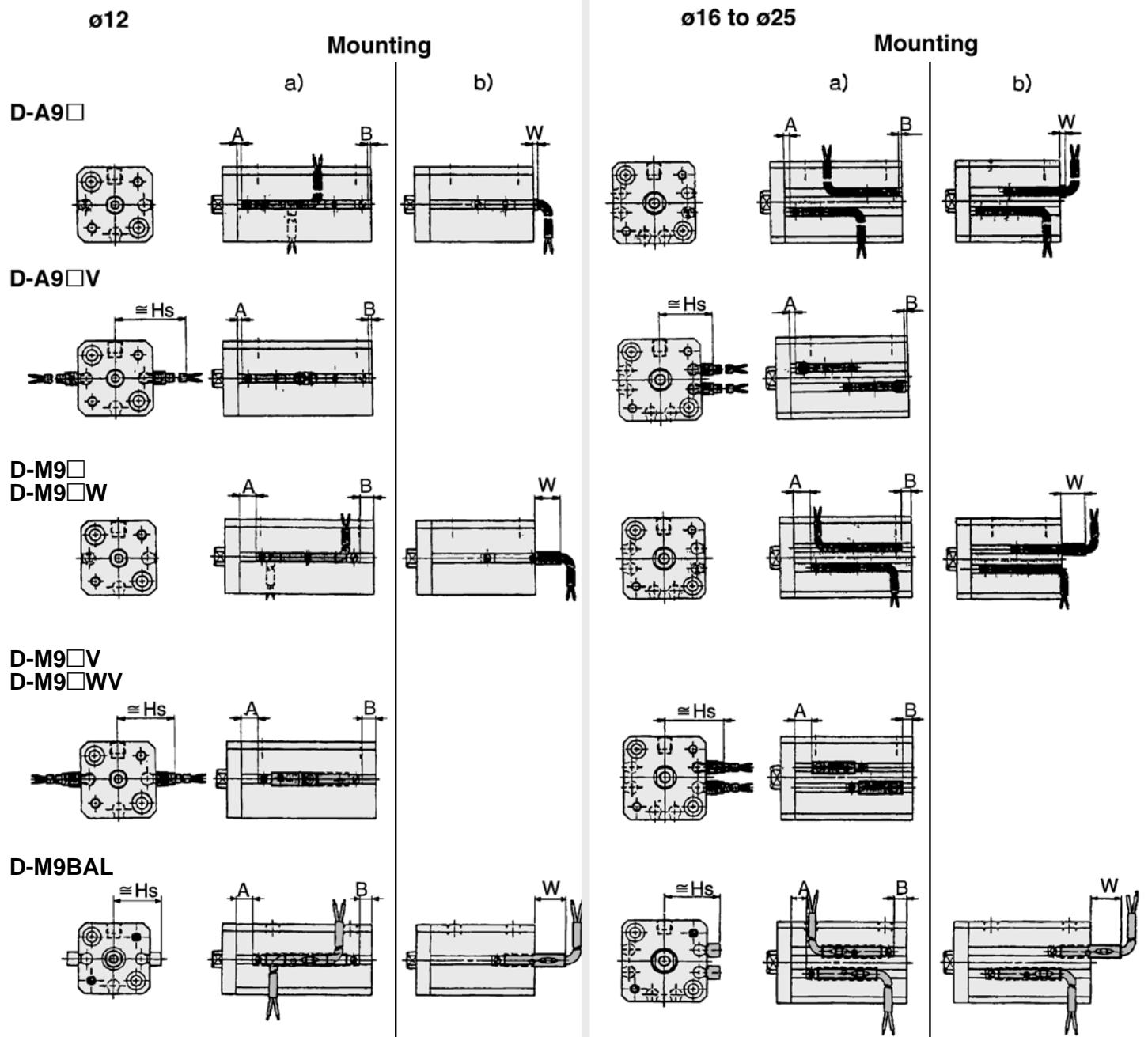

Auto switch model	D-A9□			D-A9□V			D-M9N/D-M9B D-M9P/D-M9□W			D-M9□V/D-M9□WV			
Symbol	A	B	W	A	B	Hs	A	B	W	A	B	W	
Bore size (mm)	12	1.5	0	1.5(4)	1.5	0	17	5.5	4.5	5.5	5.5	4.5	19
	16	2	0	2(4.5)	2	0	19	6	4	6	6	4	21
	20	6	3.5	-1.5(1)	6	3.5	22.5	10	7.5	2.5	10	7.5	24.5
	25	7	5.5	-3.5(-1)	7	5.5	24.5	11	9.5	0.5	11	9.5	26.5

Auto switch model	D-M9BAL				
Symbol	A	B	W	Hs	
Bore size (mm)	12	4.5	3.5	14.5	16.5
	16	5	3	15	18.5
	20	9	6.5	11.5	22
	25	10	8.5	9.5	24

Note 1) The product is shipped out of the factory in installation state "a)".
To change the electrical entry direction of the switch on the head, refer to installation state "b)".