

未注公差/General tolerances(mm)											0.1/10		
0	>3	>5	>10	>18	>30	>50	>80	>120	>180	>250		>315	>400
±0.12	±0.18	±0.22	±0.26	±0.31	±0.37	±0.57	±0.80	±0.93	±1.05	±1.15	±1.60	±2.20	±2.50

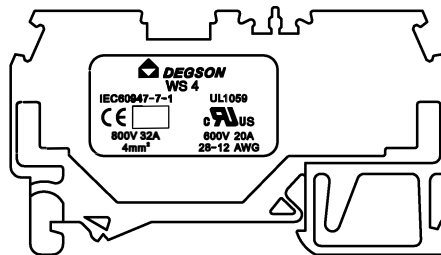
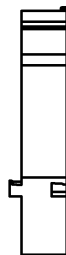
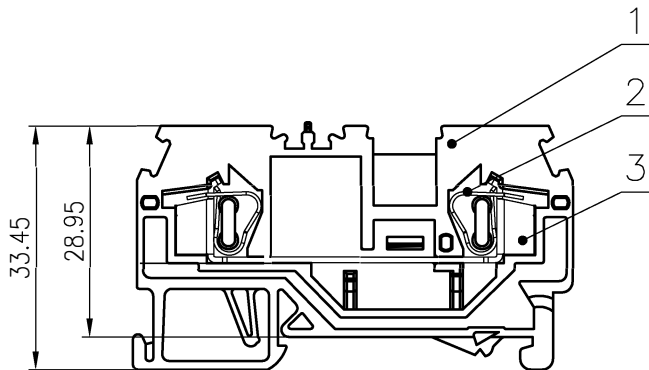
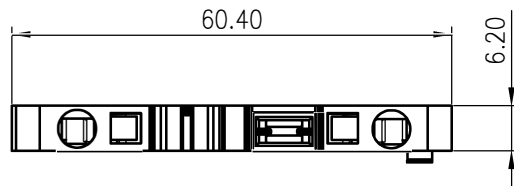

UL 标准/UL Standard:	B	C	D
额定电压/电流/Rated Voltage(V)/Current(A)	600/20	600/20	600/5
IEC 标准/IEC Standard:			
过压类别/Overvoltage Category/污染等级/Pollution Degree	III/3	/	/
额定电压/电流/Rated Voltage(V)/Current(A)	800/32	/	/
额定脉冲电压(KV)/Rate Impulse Voltage(KV)	8.0		
线径范围(硬线和软线)/Wire Range(rigid and flexible)(mm ² /AWG)	0.2~4/28~12		
间距/Pitch(mm)	6.20		
剥线长度/Stripping length(mm)	13-14		
使用温度范围/Operating temperature(°C)	-40~+105		
符合RoHS环保要求/Conform to RoHS	Yes		
标准颜色编号/Standard color number: PANTONE / RAL	/		

ITEM	NAME OF PART	MATERIAL	NOTES
3	Current carrier	Copper	Sn Plated
2	Spring	Stainless steel	
1	Housing	PA66	UL94V-0

REV	ECN	DESCRIPTION	DRFT	DATE

MATERIAL: /	SURFACE: /		
MAT NO.: /	宁波高松电子有限公司 NINGBO DEGSON ELECTRICAL CO., LTD		
STATUS: /			
APPD: Li GL 2020.04.04	NAME: WS4-01P-1Y-00A(H)		
CHKD: Mao J 2020.04.04	DRAWING NO.: WS4-C01		
DRFT: Wang LX 2020.04.04	REV	T3	
SIZE: A4	TYPE: CUSTOMER DRAWING	SCALE: 1:1	SHEET 1/1