

- NOTES:**
1. Rating:300V 10A;
  2. Insulation Withstands Voltage:  
AC2000V/MIN;
  3. Insulation Resistance:  
500MΩ or more at DC500V
  4. Using Temperature Range:  
-40°C/+105°C;
  5. Screw Torque Vlaue:0.4N.m;
  6. Suitable Electric Wire: 16-26AWG .
  7. "★" is critical dimension to be controlled.

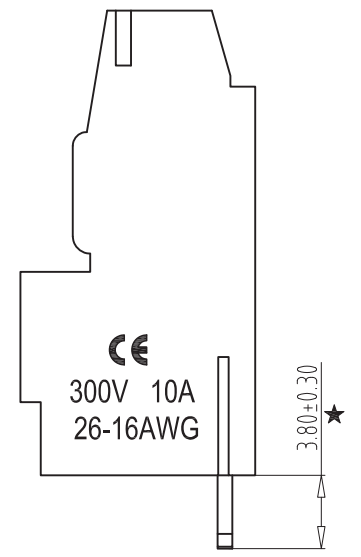
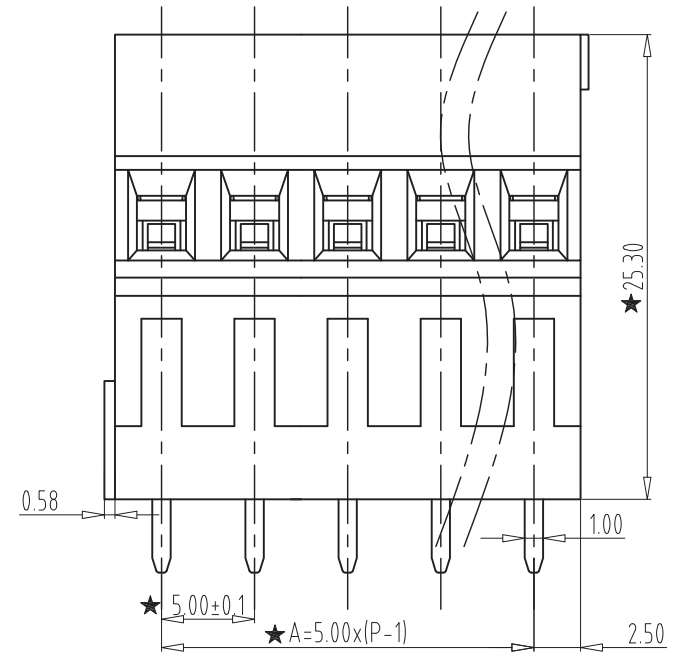
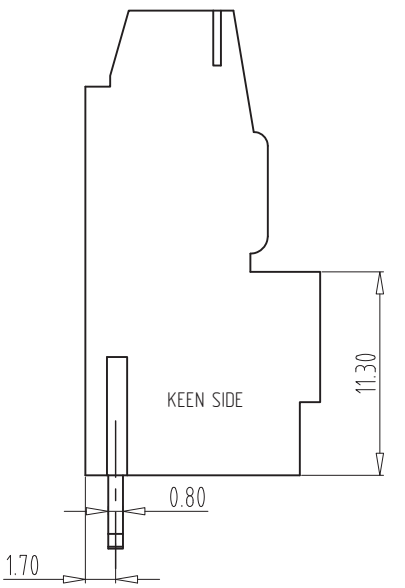

Total Pitch Tolerances in mm										Nominal dimension range in mm										⊥	≡	—	//							
over 0	over 30	over 53	over 70	over 90	over 115	over 150	over 250	over 350	over 500	over 0	over 30	over 53	over 70	over 90	over 115	over 150	over 200	over 250	over 320	over 0	over 10	all	over 0	over 100	over 150	over 150				
±0.18	±0.25	±0.30	±0.35	±0.40	±0.45	±0.60	±0.70	±0.85	±0.20	±0.25	±0.30	±0.35	±0.44	±0.55	±0.70	±0.80	±0.90	0.2	0.3	0.3	0.2	0.3	0.5							

ITEM	NAME OF PART	NO. OF PART	Q'TY	MATERIAL	NOTE
DWG.	SK	DATE	SIZE	A4 UNITS mm	SHEET/OF
CHK.		DATE	SCALE		
APP.		DATE		NAME KSE-128H-5.0-XX	
KEEN SIDE ELECTRONICS					