

BOM LIST			
ITEM	PART NAME	Q'ty	NOTES
1	PLASTIC HOOD	2	ABS
2.1	LONG BOLT	2	#4-40
2.2	SHORT BOLT	2	#4-40
3	NUT	2	M3
4	LONG SCREW	2	M3
5	SMALL WASHER	2	M3
6	SHORT SCREW	2	M3
7.1	METAL WASHER	2	M3
7.2	PLASTIC-1 WASHER	2	ABS
7.3	PLASTIC-2 WASHER	2	ABS

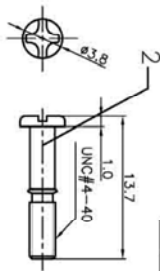

Short BOLT

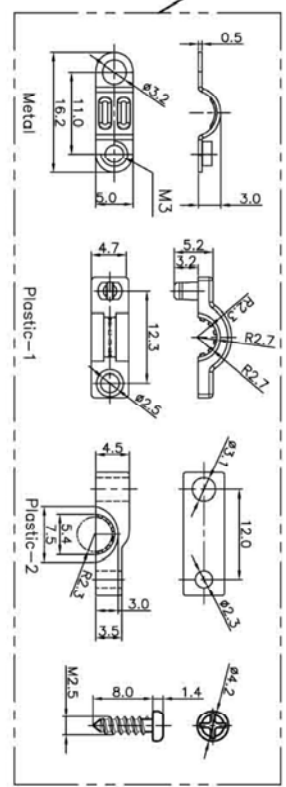
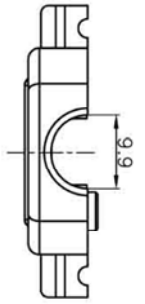
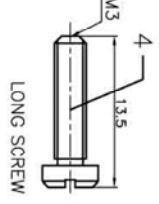

LONG SCREW

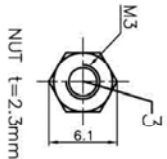

NUT t=2.3mm

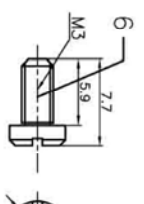

SHORT SCREW

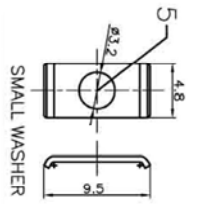

SMALL WASHER

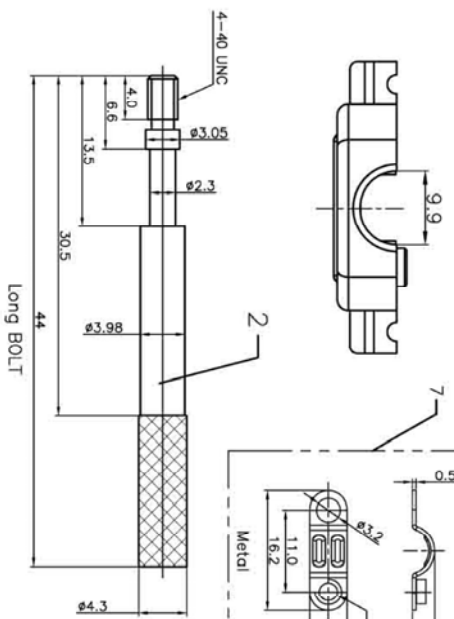

Long BOLT

DNT-15C LONG SCREW
DN-15C SHORT SCREW

ITEM	NAME OF PART	NO. OF PART	Q'TY	MATERIAL	NOTE
DWG	ZX	DATE	SIZE	A4	SHEET/OF 1/1
CHK	DATE	SCALE		mm	
APP.	DATE				
NAME			D-SUB 15pin Hood		
DWGNO.					