

LCD MODULE

MODULE NO. :

KSEGB12864XXX-02 SERIES**Customer:**

Approved by:

Approved by	Checked by	Prepared by

RECORDS OF REVISION

Part Number	Revision	Revision Content	Revised on
KSEGB12864XXX-02	1.0	First issue	Oct. 15th, 2022

CONTENTS

1. MODULE CLASSIFICATION INFORMATION 3

2. FUNCTIONS & FEATURES 4

3. MODULE ARTWORK4

4. EXTERNAL DIMENSIONS 5

5. BLOCK DIAGRAM 6

6. PIN ASSIGNMENT 6

7. BACKLIGHT ELECTRICAL/OPTICAL SPECIFICATIONS 7

8. ABSOLUTE MAXIMUM RATINGS7

9. ELECTRICAL CHARACTERISTICS 7

10. COMMAND DEFINITIONS 9

11. OPTICAL CHARACTERISTICS 11

12. MODULE ACCEPT QUALITY LEVEL (AQL) 13

13. RELIABILITY TEST 13

14. INSPECTION SPECIFICATION14

15. LCD MODULES HANDLING PRECAUTIONS17

16. OTHERS 17

1. MODULE CLASSIFICATION INFORMATION

KSE G B 12864 - XXX - 02 - X

① ② ③ ④ ⑤ ⑥ ⑦ ⑧ ⑨

- ① KSE: KEEN SIDE electronics
- ② C: Character Type, G: Graphic Type
- ③ B: COB, G: COG
- ④ Display Font: 128 * 64
- ⑤ LCD Mode: B→ STN-Blue Negative F→ FSTN Positive
 G→ STN Gray Positive Y→ STN Yellow Green Positive

- ⑥ Backlight Type: N→ Without backlight A→ Amber LED backlight
 B→ Blue LED backlight G→ Green LED backlight

 R→ Red LED backlight W→ Withe LED backlight

 Y→ Yellow-Green LED backlight

- ⑦ LCD Polarizer Type/Temperature range/View direction :
 D→ Transflective, W.T, 12:00 E→ Transmissive, W.T, 6:00
 P→ Reflective, W. T, 6:00 Q→ Transmissive, W.T, 12:00
 Z→ Transflective, W.T, 6:00

- ⑧ Model serials no. :

- ⑨ Special Code: V : Built in negative voltage& Temperature Compensation

2. FUNCTIONS & FEATURES

- KSEGB12864XXX-02 SERIES TYPE:
- Driving Scheme : 1/64Duty, 1/9 Bias
- Power Supply for logic : 5.0V
- Display Content : 128*64 Dots
- V_{LCD} : 9.0V
- Operation temperature : -20°C to +70°C
- Storage temperature : -30°C to +80°C

3. MODULE ARTWORK

- Module Size : 93.00(L)*70.00 (W)*12.50(H)mm
- Viewing Area : 72.00(L)mm*39.00 (W)mm
- Active Area : 66.52(L)mm*33.24(W)mm
- Dot Pitch : 0.52 (W)mm*0.52 (H)mm
- Dot Size : 0.48(W)mm*0.48 (H)mm
- Dot Gap : 0.04 mm

4. EXTERNAL DIMENSIONS

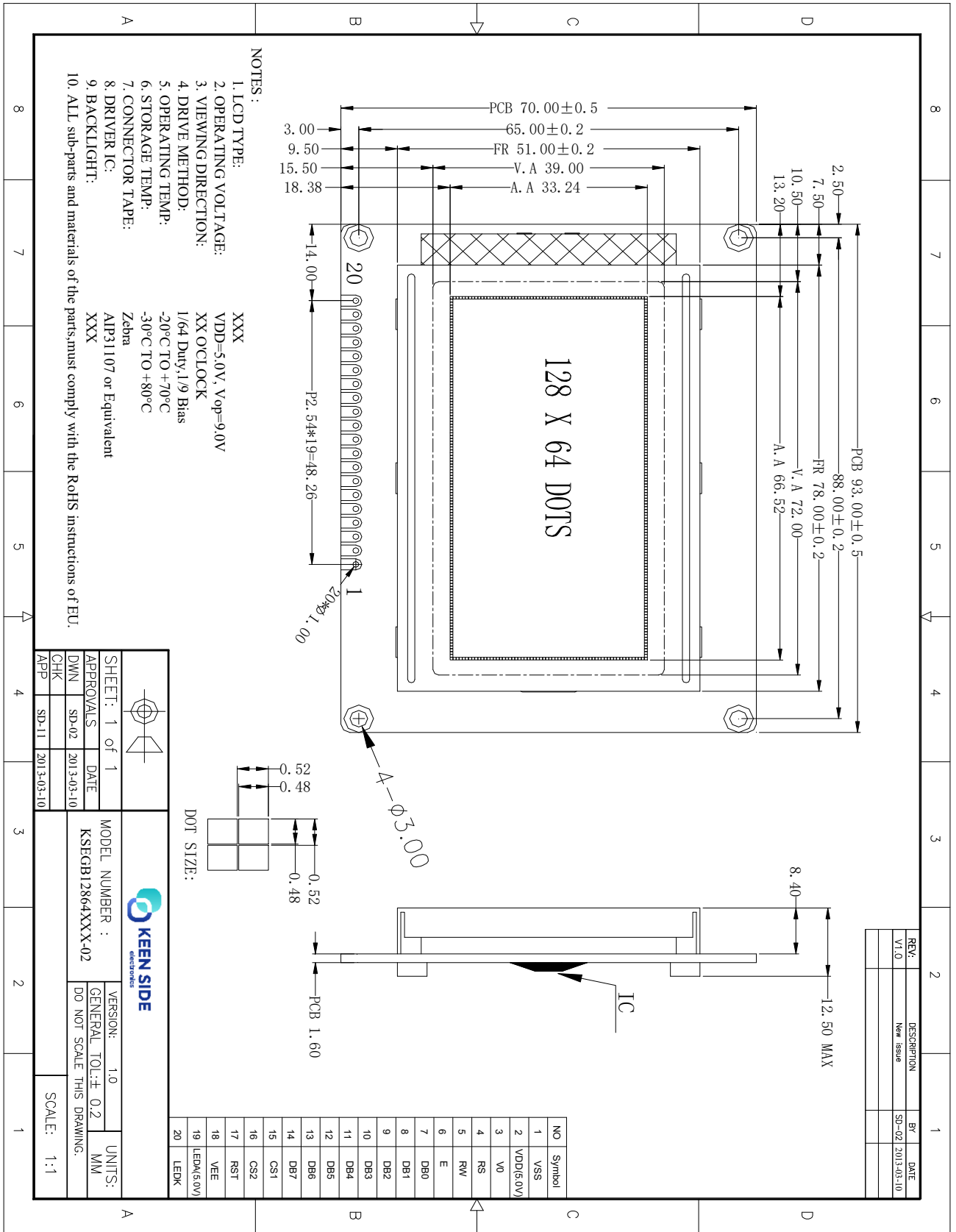

REV.	DESCRIPTION	BY	DATE
V1.0	New Issue	SP-02	2013-03-10

SHEET: 1 of 1		MODEL NUMBER: KSEGB12864XXX-02	
APPROVALS	DATE	VERSION: 1.0	UNITS: MM
DWN	2013-03-10	GENERAL TOL: ± 0.2	
CHK		DO NOT SCALE THIS DRAWING.	
APP	SD-11 2013-03-10	SCALE: 1:1	

5. BLOCK DIAGRAM

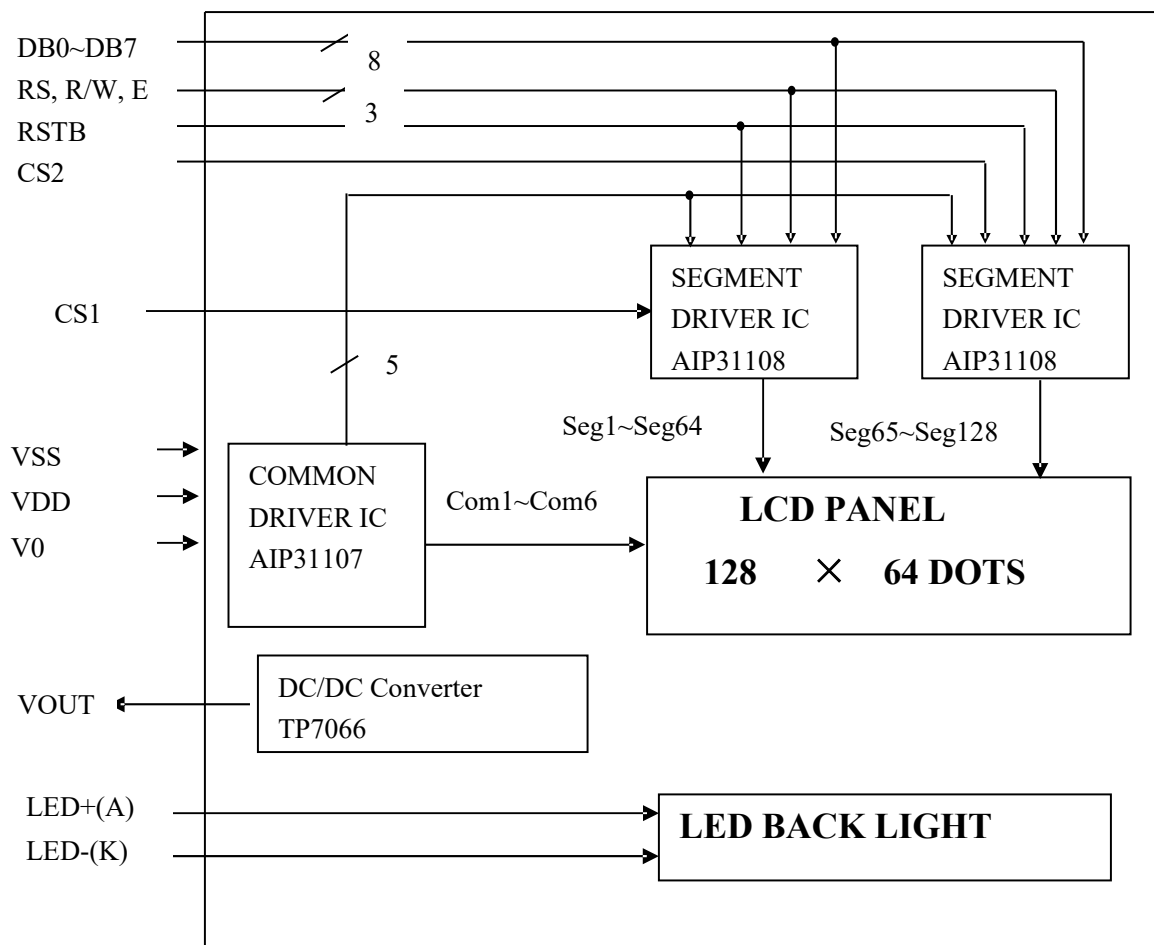

6. PIN ASSIGNMENT

Pin No.	Symbol	Function
1	VSS	Ground
2	VDD	Power supply voltage for logic
3	V0	Input voltage for LCD
4	RS	Register select RS = 0...Instruction register RS = 1...Data register
5	R/W	Read /Write R/W = 1...Read R/W = 0...Write
6	E	Chip enable signal
7	DB0	Data bit 0
8	DB1	Data bit 1
9	DB2	Data bit 2
10	DB3	Data bit 3
11	DB4	Data bit 4
12	DB5	Data bit 5
13	DB6	Data bit 6
14	DB7	Data bit 7
15	CS1	Chip select signal for SBN0064(1)
16	CS2	Chip select signal for SBN0064(2)
17	RST	Reset signal
18	VEE	Output voltage for LCD,-9.0V
19	LED + (A)	Anode of LED backlight
20	LED - (K)	Cathode of LED backlight

7. BACKLIGHT ELECTRICAL/OPTICAL SPECIFICATIONS

Item	Symbol	MIN.	TYP.	MAX.	Unit	Conditions
Forward Voltage	Vf	4.8	5.0	5.2	V	If =15*4mA
Forward Current	If		60		mA	
Power Dissipation	Pd		0.30		W	If =15*4mA
Reverse Voltage	VR			5.0	V	
Reverse Current	IR			0.4	mA	
Luminous Intensity	Lv	100			cd/m ²	If =15*4mA
Luminous Uniformity	Δ Lv	70			%	If = 15*4mA
Emission Wavelength	x	0.27		0.30		If=15*4mA, Ta=25°C
	y	0.27		0.30		
Backlight Color	White					

8. ABSOLUTE MAXIMUM RATINGS

Item	Symbol	Standard value	Unit
Supply voltage for logic	V _{DD}	-0.3~+7.0	V
Supply voltage	V ₀	V _{DD} -19.0~V _{DD} +0.3	V
Driver supply voltage	V _{DD} -V ₀	V ₀ -0.3~V _{DD} +0.3	V
Operating temperature	Topr	-20~+70	°C
Storage temperature	Tstg	-25~+75	°C

9. ELECTRICAL CHARACTERISTICS

1). DC Characteristics

Item	Symbol	Standard Value			Test Condition	Unit
		MIN	TYP	MAX		
Supply voltage for logic	V _{DD}	4.8	5.0	5.2	-----	V
Supply current for logic	I _{DD}	----	2.7	5	-----	mA
operating Voltage for LCD	V _{DD} -V ₀	10.8	11.0	11.2	-20°C	V
		8.8	9.0	9.2	25°C	
		8.0	8.2	8.4	70°C	
Input voltage “H” level	V _{IH}	0.7V _{DD}	---	V _{DD}	---	V
Input voltage “L” level	V _{IL}	0	---	0.3V _{DD}	---	V

2). AC Characteristics

Characteristic	Symbol	Min	Typ	Max	Unit
E Cycle	t_C	1000	-	-	ns
E Rise	t_R	-	-	25	ns
E Fall	t_F	-	-	25	ns
E High Level Width	t_{WH}	450	-	-	ns
E-Low Level Width	t_{WL}	450	-	-	ns
Address Set-Up Time	t_{ASU}	140	-	-	ns
Address Hold Time	t_{AH}	10	-	-	ns
Data Delay Time	t_D	-	-	320	ns
Data Set-Up Time	t_{DSU}	200	-	-	ns
Data Hold Time (Write)	t_{DHW}	10	-	-	ns
Data Hold Time (Read)	t_{DHR}	20	-	-	ns

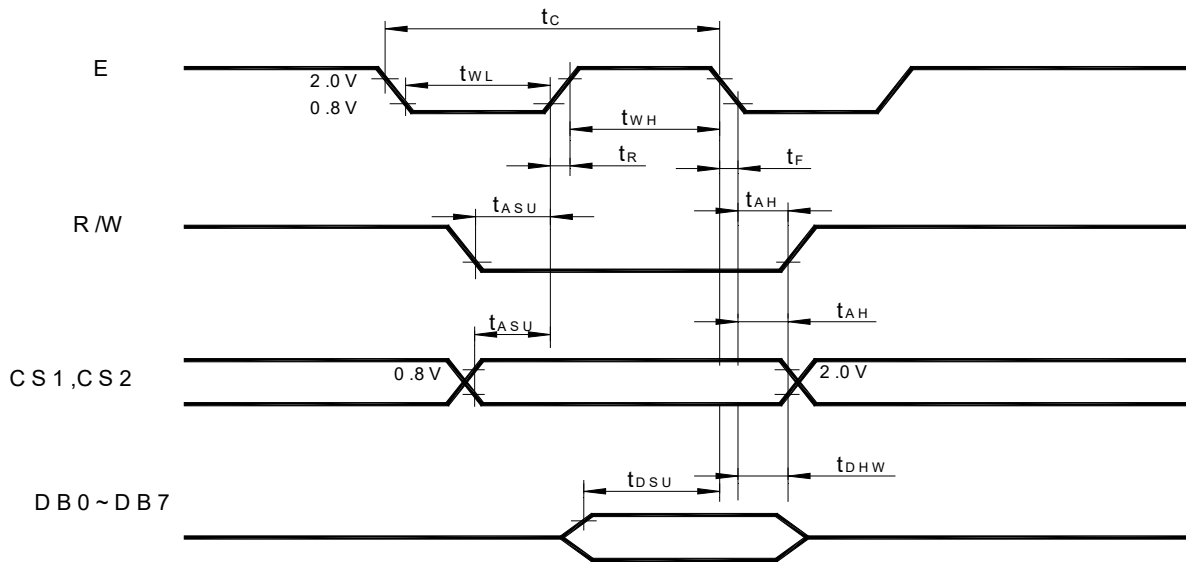
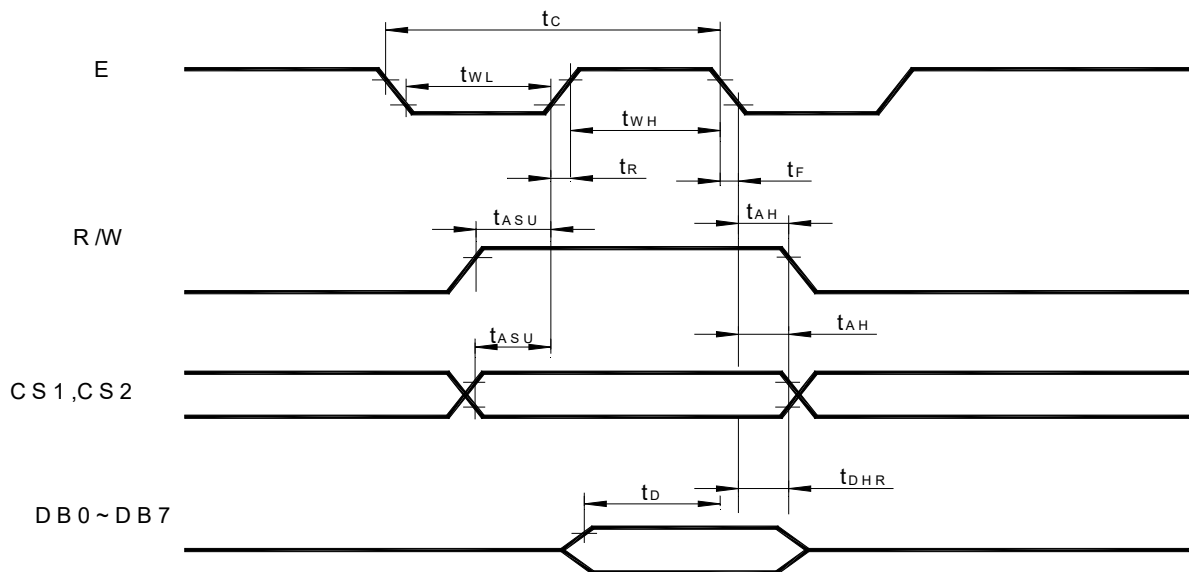

Figure 5.0 MPU write timing



10. COMMAND DEFINITIONS

The display control instructions the internal state of the SBN0064. Instruction is received from MPU to AIP31070 for the display control. The following table shows various instructions.

Instruction	RS	R/W	DB7	DB6	DB5	DB4	DB3	DB2	DB1	DB0	Function	
Display ON/OFF	L	L	L	L	H	H		H	H	L/H	Controls the display on or off. Internal status and display RAM data is not affected. L: OFF, H: ON	
Set Address (Y address)	L	L	L	H	Y address (0~63)						Sets the Y address in the Y address counter.	
Set Page (X address)	L	L	H	L	H	H	H	Page (0~7)			Sets the X address At the X address counter	
Display Start line (Z address)	L	L	H	H	Display start line (0~63)						Indicates the display data RAM displayed at the top of the screen.	
Status Read	L	H	B U S Y	L	O N / O F F	R E S E T	L	L	L	L	Read status BUSY L: Ready H: In operation On/Off L: display ON H: Display OFF RESET L: Normal H: Reset	
Write Display Data	H	L	Write Date									Writes data (DB0:7) into display data RAM . After writing instruction, Y address is increased by 1 automatically.
Read Display data	H	H	Read Date									Reads data (DB0:7) From display data RAM to the data bus.

10-1. Display On/Off

RS	R/W	DB7	DB6	DB5	DB4	DB3	DB2	DB1	DB0
0	0	0	0	1	1	1	1	1	D0

The display data appears when D is 1 and disappears when D is 0.

Though the data is not on the screen with D=0, it remains display data RAM.

Therefore, you can make it appear by changing D=0 into D=1.

10-2. Set Address (Y Address)

RS	R/W	DB7	DB6	DB5	DB4	DB3	DB2	DB1	DB0
0	0	0	1	AC5	AC4	AC3	AC2	AC1	AC0

Y address (AC0~AC5) of the display data RAM is set in the Y address counter.

An address is set by instruction and increased by 1 automatically by read or write operations of display data.

10-3. Set Page (X Address)

RS	R/W	DB7	DB6	DB5	DB4	DB3	DB2	DB1	DB0
0	0	1	0	1	1	1	AC2	AC1	AC0

X address (AC0~AC2) of the display data RAM is set in the X address register.

Writing or reading to or from MPU is executed in this specified page until the next page is set.

10-4. Display Start Line (Z Address)

RS	R/W	DB7	DB6	DB5	DB4	DB3	DB2	DB1	DB0
0	0	1	1	AC5	AC4	AC3	AC2	AC1	AC0

Z address (AC0~AC5) of the display data RAM is set in the display start line register and display at the top of the screen.

When the display duty cycle is 1/64 or others (1/32~1/64), the data of total line number of LCD screen, from the line

specified by display start line instruction, is displayed.

10-5. Status Read

RS	R/W	DB7	DB6	DB5	DB4	DB3	DB2	DB1	DB0
0	0	BUSY	0	ON/OFF	RESET	0	0	0	0

■ **BUSY**

When BUSY is 1, the Chip is executing internal operation and no instructions are accepted.

When BUSY is 0, the Chip is ready to accept any instructions.

■ **ON/OFF**

When ON/OFF is 1, the display is on.

When ON/OFF is 0, the display is off.

■ **RESET**

When RESET is 1, the system is being initialized.

In this condition is 0, no instructions except status read can be accepted.

When RESET is 0, initialized has finished and the system is in the usual operation condition

10-6. Write Display data

R/W	DB7	DB6	DB5	DB4	DB3	DB2	DB1	DB0
1	D7	D6	D5	D4	D3	D2	D1	D0

Writes data (D0~D7) into the display data RAM.

After writing instruction, Y addressed is increased 1 automatically.

10-7. Read Display data

R/W	DB7	DB6	DB5	DB4	DB3	DB2	DB1	DB0
1	D7	D6	D5	D4	D3	D2	D1	D0

Reads data (D0~D7) from the display data RAM.

After reading instruction, Y addressed is increased 1 automatically.

11. OPTICAL CHARACTERISTICS

11.1 Definition of Viewing Angle

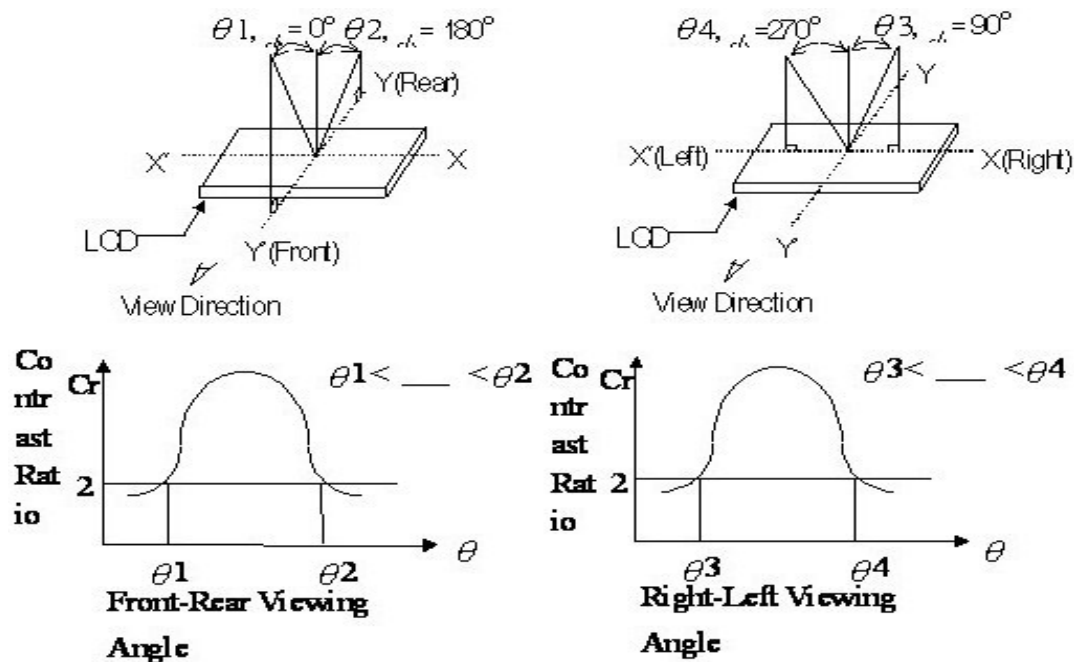

11.2 Definition of Contrast

$$\text{RATIO}$$

$$\text{C.R} = \frac{\text{Brightness of nonselected segment (E2)}}{\text{Brightness of selected segment}}$$

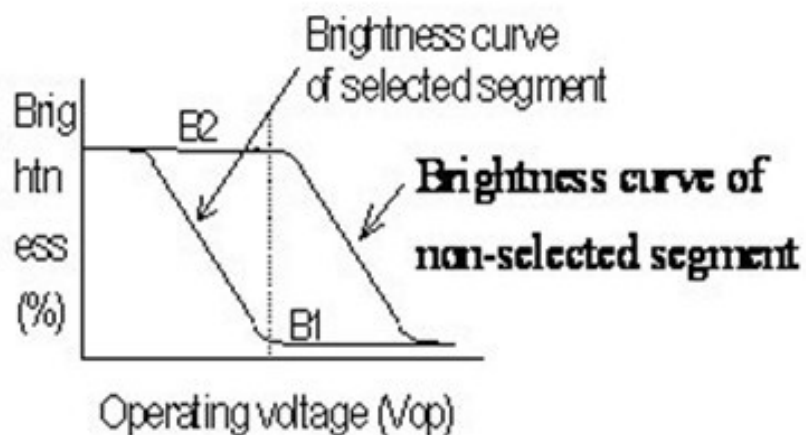

11.3 Definition of Response

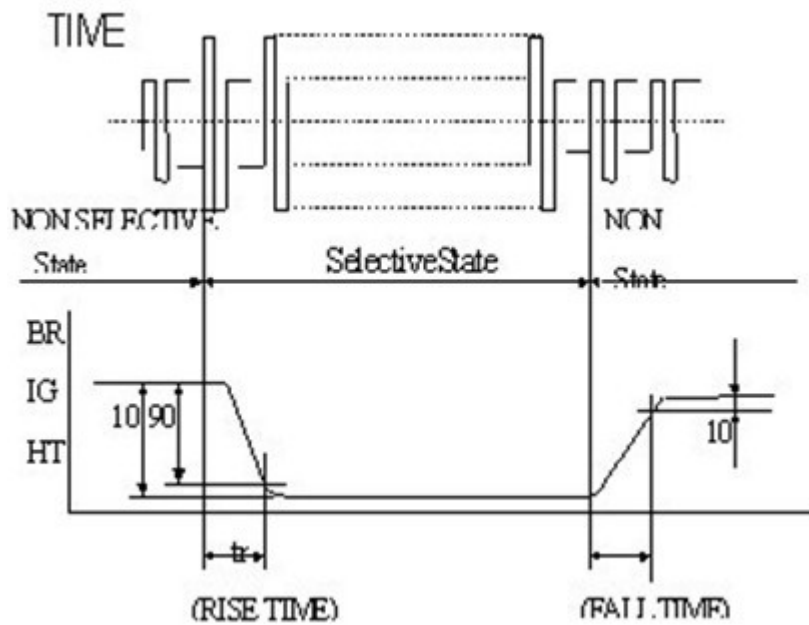

11.4 Measuring Instruments For Elector-optical Characteristics

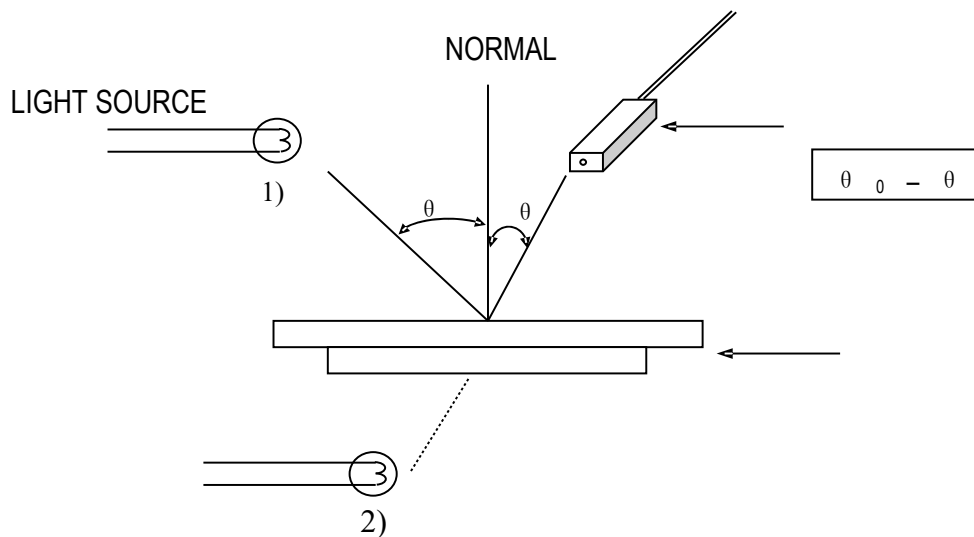

*** Note:**

- 1) Light source position for measuring the reflective type of LCD panel;
- 2) Light source position for measuring the transfective / transmissive types of LCD panel.

12. MODULE ACCEPT QUALITY LEVEL (AQL)

12.1 AQL Standard Value: Critical Defect =0.1, Major Defect=0.65; Minor Defect =2.5.

12.2 Inspection Standard: MIL-STD-105E Table Normal Inspection Single Sampling Level II

13. RELIABILITY TEST

Operating life time: Longer than 75,000 hours

(at room temperature without direct irradiation of sunlight)

Reliability characteristics shall meet following requirements.

No.	Test Item	Content of Test	Test Condition
1	High Temperature Storage	Endurance test applying the high temperature for a long time storage	+80°C 96H
2	Low Temperature Storage	Endurance test applying the low temperature for a long time storage	-30°C 96H
3	High Temperature Operation	Endurance test applying the electric stress (voltage & current) and the thermal stress to the element for a long time	+70°C 96H
4	Low Temperature Operation	Endurance test applying the electric stress under low temperature for a long time	-20°C 96H
5	High Temperature/ Humidity Storage	Endurance test applying the high temperature and humidity storage for a long time	40°C 90%RH 96H
6	Temperature Cycle	Endurance test applying the low and high temperature cycle -20°C \longleftrightarrow 25°C \longleftrightarrow 70°C \longleftrightarrow 25°C 30min 5min 30min 5min \longleftarrow 1 cycle \longrightarrow	-20°C/70°C 5 cycles
7	Vibration Test (Package State)	Endurance test applying the vibration during transportation	10Hz - 55Hz, 50m/s, 15min
8	Shock Test (Package State)	Endurance test applying the shock during transportation	Half-sinewave, 100m/s, 11ms
9	Atmospheric Pressure Test	Endurance test applying the atmospheric pressure during transportation by air	40 kPa 16 H

14. Inspection specification

14.1 Visual Inspection

- 1) Inspect under 2x20W or 40W fluorescent lamp (approximately 3000 lux) leaving 25 to 30 cm between the module and the lamp and 30 cm between the module and the eye (measuring position).
- 2) Appearance is inspected at the best contrast voltage (best contrast is adjusted considering clearness and crosstalk on screen).
- 3) Inspect the module at 45° right and left, top and bottom.
- 4) Use the optimum viewing angle during the contrast inspection.

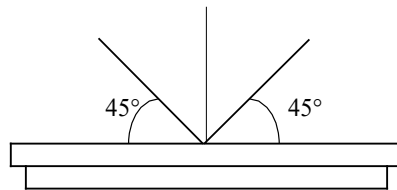

14.2 Standard of Appearance Inspection

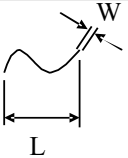
No.	Item	Criteria																					
1	Black spot White spot Dust	Round type: as per following drawing $\Phi = (X+Y)/2$ 																					
		<table border="1"> <thead> <tr> <th colspan="3">Acceptable quantity</th> </tr> <tr> <th>Size</th> <th>Zone A</th> <th>Zone B</th> </tr> </thead> <tbody> <tr> <td>$\Phi < 0.1$</td> <td>Any number</td> <td rowspan="4">Any number</td> </tr> <tr> <td>$0.1 < \Phi < 0.2$</td> <td>2</td> </tr> <tr> <td>$0.2 < \Phi < 0.25$</td> <td>1</td> </tr> <tr> <td>$0.25 < \Phi$</td> <td>0</td> </tr> </tbody> </table>	Acceptable quantity			Size	Zone A	Zone B	$\Phi < 0.1$	Any number	Any number	$0.1 < \Phi < 0.2$	2	$0.2 < \Phi < 0.25$	1	$0.25 < \Phi$	0						
Acceptable quantity																							
Size	Zone A	Zone B																					
$\Phi < 0.1$	Any number	Any number																					
$0.1 < \Phi < 0.2$	2																						
$0.2 < \Phi < 0.25$	1																						
$0.25 < \Phi$	0																						
		Line type: as per following drawing <table border="1"> <thead> <tr> <th colspan="4">Acceptable quantity</th> </tr> <tr> <th>Length</th> <th>Width</th> <th>Zone A</th> <th>Zone B</th> </tr> </thead> <tbody> <tr> <td>—</td> <td>$W \leq 0.02$</td> <td>Any number</td> <td rowspan="4">Any number</td> </tr> <tr> <td>$L \leq 3.0$</td> <td>$0.02 < W \leq 0.03$</td> <td>2</td> </tr> <tr> <td>$L \leq 2.5$</td> <td>$0.03 < W \leq 0.05$</td> <td>2</td> </tr> <tr> <td>—</td> <td>$0.05 < W$</td> <td>As round type</td> </tr> </tbody> </table> 	Acceptable quantity				Length	Width	Zone A	Zone B	—	$W \leq 0.02$	Any number	Any number	$L \leq 3.0$	$0.02 < W \leq 0.03$	2	$L \leq 2.5$	$0.03 < W \leq 0.05$	2	—	$0.05 < W$	As round type
Acceptable quantity																							
Length	Width	Zone A	Zone B																				
—	$W \leq 0.02$	Any number	Any number																				
$L \leq 3.0$	$0.02 < W \leq 0.03$	2																					
$L \leq 2.5$	$0.03 < W \leq 0.05$	2																					
—	$0.05 < W$	As round type																					
		Total acceptable quantity: 3																					
2	Polariser scratch	Scratch on protective film is permitted Scratch on polariser: same as No. 1																					
3	Polariser bubble	$\Phi = (X+Y)/2$																					

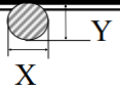
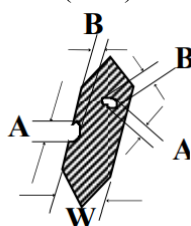
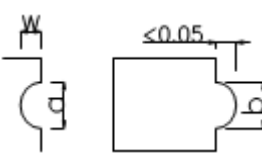
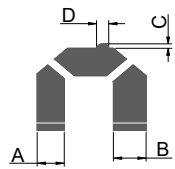
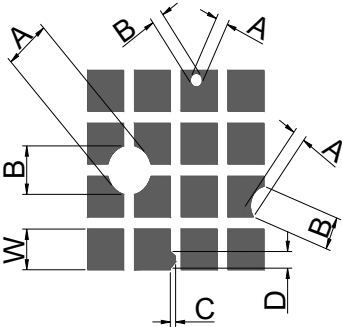
		 <table border="1" data-bbox="766 190 1428 459"> <thead> <tr> <th colspan="3">Acceptable quantity</th> </tr> <tr> <th>Size</th> <th>Zone A</th> <th>Zone B</th> </tr> </thead> <tbody> <tr> <td>$\Phi < 0.2$</td> <td>Any number</td> <td rowspan="4">Any number</td> </tr> <tr> <td>$0.2 < \Phi < 0.5$</td> <td>2</td> </tr> <tr> <td>$0.5 < \Phi < 1.0$</td> <td>1</td> </tr> <tr> <td>$1.0 < \Phi$</td> <td>0</td> </tr> </tbody> </table> <p>Total acceptable quantity: 3</p>	Acceptable quantity			Size	Zone A	Zone B	$\Phi < 0.2$	Any number	Any number	$0.2 < \Phi < 0.5$	2	$0.5 < \Phi < 1.0$	1	$1.0 < \Phi$	0																					
Acceptable quantity																																						
Size	Zone A	Zone B																																				
$\Phi < 0.2$	Any number	Any number																																				
$0.2 < \Phi < 0.5$	2																																					
$0.5 < \Phi < 1.0$	1																																					
$1.0 < \Phi$	0																																					
4	Segment deformation	<p>4.1 Pin hole on segmented display W: segment width $\Phi = (A+B)/2$</p>  <table border="1" data-bbox="837 627 1428 952"> <thead> <tr> <th colspan="2">Acceptable quantity</th> </tr> <tr> <th>Width</th> <th>Quantity</th> </tr> </thead> <tbody> <tr> <td>$W \leq 0.4$</td> <td>$\Phi \leq 0.2$ and $\Phi \leq 1/2W$</td> </tr> <tr> <td>$W > 0.4$</td> <td>$\Phi \leq 0.25$ and $\Phi \leq 1/3W$</td> </tr> </tbody> </table> <p>Total acceptable quantity: 1 defect per segment Pin holes with Φ under 0.10 mm are acceptable</p> <p>4.2 Pin hole on dot matrix display</p>  <table border="1" data-bbox="981 1019 1428 1232"> <thead> <tr> <th colspan="2">Acceptable quantity</th> </tr> <tr> <th>Size</th> <th>Quantity</th> </tr> </thead> <tbody> <tr> <td>$a, b < 0.1$</td> <td>Any number</td> </tr> <tr> <td>$(a+b)/2 \leq 0.1$</td> <td>Any number</td> </tr> <tr> <td>$0.5 < \Phi < 1.0$</td> <td>3</td> </tr> </tbody> </table> <p>Total acceptable quantity: 7</p> <p>4.3 Segments / dots with different width</p>  <table border="1" data-bbox="981 1377 1340 1489"> <thead> <tr> <th colspan="2">Acceptable</th> </tr> </thead> <tbody> <tr> <td>$a \geq b$</td> <td>$a/b \leq 4/3$</td> </tr> <tr> <td>$a < b$</td> <td>$a/b > 4/3$</td> </tr> </tbody> </table> <p>4.4 Alignment layer defect $\Phi = (A+B)/2$</p>  <table border="1" data-bbox="989 1680 1428 1993"> <thead> <tr> <th colspan="2">Acceptable quantity</th> </tr> <tr> <th>Size</th> <th>Quantity</th> </tr> </thead> <tbody> <tr> <td>$\Phi \leq 0.4$</td> <td>Any number</td> </tr> <tr> <td>$0.4 < \Phi \leq 1.0$</td> <td>5</td> </tr> <tr> <td>$1.0 < \Phi \leq 1.5$</td> <td>3</td> </tr> <tr> <td>$1.5 < \Phi \leq 2.0$</td> <td>2</td> </tr> </tbody> </table> <p>Total acceptable quantity: 7</p>	Acceptable quantity		Width	Quantity	$W \leq 0.4$	$\Phi \leq 0.2$ and $\Phi \leq 1/2W$	$W > 0.4$	$\Phi \leq 0.25$ and $\Phi \leq 1/3W$	Acceptable quantity		Size	Quantity	$a, b < 0.1$	Any number	$(a+b)/2 \leq 0.1$	Any number	$0.5 < \Phi < 1.0$	3	Acceptable		$a \geq b$	$a/b \leq 4/3$	$a < b$	$a/b > 4/3$	Acceptable quantity		Size	Quantity	$\Phi \leq 0.4$	Any number	$0.4 < \Phi \leq 1.0$	5	$1.0 < \Phi \leq 1.5$	3	$1.5 < \Phi \leq 2.0$	2
Acceptable quantity																																						
Width	Quantity																																					
$W \leq 0.4$	$\Phi \leq 0.2$ and $\Phi \leq 1/2W$																																					
$W > 0.4$	$\Phi \leq 0.25$ and $\Phi \leq 1/3W$																																					
Acceptable quantity																																						
Size	Quantity																																					
$a, b < 0.1$	Any number																																					
$(a+b)/2 \leq 0.1$	Any number																																					
$0.5 < \Phi < 1.0$	3																																					
Acceptable																																						
$a \geq b$	$a/b \leq 4/3$																																					
$a < b$	$a/b > 4/3$																																					
Acceptable quantity																																						
Size	Quantity																																					
$\Phi \leq 0.4$	Any number																																					
$0.4 < \Phi \leq 1.0$	5																																					
$1.0 < \Phi \leq 1.5$	3																																					
$1.5 < \Phi \leq 2.0$	2																																					
5	Colour uniformity	Level of sample for approval set as limit sample																																				

6	Backlight	The backlight colour should correspond to the product specification Flashing and or unlit backlight is not allowed Dust larger than 0.25 mm is not allowed																
7	COB	Exposed wire bond pad is not allowed Insufficient covering with resin is not allowed (wire bond line exposed) Dust or bubble on the resin are not allowed																
8	PCB	No unmelted solder paste should be present on PCB Cold solder joints, missing solder connections, or oxidation are not allowed No residue or solder balls on PCB are allowed Short circuits on components are not allowed																
9	Tray particles	<table border="1"> <thead> <tr> <th colspan="3">Acceptable quantity</th> </tr> <tr> <th></th> <th>Size</th> <th>Quantity</th> </tr> </thead> <tbody> <tr> <td rowspan="2">On tray</td> <td>$\Phi < 0.2$</td> <td>Any number</td> </tr> <tr> <td>$\Phi > 0.25$</td> <td>4</td> </tr> <tr> <td rowspan="2">On display</td> <td>$\Phi \geq 0.25$</td> <td>2</td> </tr> <tr> <td>L = 3</td> <td>1</td> </tr> </tbody> </table>	Acceptable quantity				Size	Quantity	On tray	$\Phi < 0.2$	Any number	$\Phi > 0.25$	4	On display	$\Phi \geq 0.25$	2	L = 3	1
Acceptable quantity																		
	Size	Quantity																
On tray	$\Phi < 0.2$	Any number																
	$\Phi > 0.25$	4																
On display	$\Phi \geq 0.25$	2																
	L = 3	1																

15. LCD MODULES HANDLING PRECAUTIONS

- Please remove the protection foil of polarizer before using.
- The display panel is made of glass. Do not subject it to a mechanical shock by dropping it from a high place, etc.
- If the display panel is damaged and the liquid crystal substance inside it leaks out, do not get any in your mouth. If the substance come into contact with your skin or clothes promptly wash it off using soap and water.
- Do not apply excessive force to the display surface or the adjoining areas since this may cause the color tone to vary.
- The polarizer covering the display surface of the LCD module is soft and easily scratched. Handle this polarize carefully.
- To prevent destruction of the elements by static electricity, be careful to maintain an optimum work environment.
 - Be sure to ground the body when handling the LCD module.
 - Tools required for assembly, such as soldering irons, must be properly grounded.
 - To reduce the amount of static electricity generated, do not conduct assembly and other work under dry conditions.
 - The LCD module is coated with a film to protect the display surface. Exercise care when peeling off this protective film since static electricity may be generated.
- Storage precautions
When storing the LCD modules, avoid exposure to direct sunlight or to the light of fluorescent lamps. Keep the modules in bags designed to prevent static electricity charging under low temperature / normal humidity conditions (avoid high temperature / high humidity and low temperatures below 0°C). Whenever possible, the LCD modules should be stored in the same conditions in which they were shipped from our company.

16. OTHERS

- Liquid crystals solidify at low temperature (below the storage temperature range) leading to defective orientation of liquid crystal or the generation of air bubbles (black or white). Air bubbles may also be generated if the module is subjected to a strong shock at a low temperature.
- If the LCD modules have been operating for a long time showing the same display patterns may remain on the screen as ghost images and a slight contrast irregularity may also appear. Abnormal operating status can be resumed to be normal condition by suspending use for some time. It should be noted that this phenomena does not adversely affect performance reliability.
- To minimize the performance degradation of the LCD modules resulting from caused by static electricity, etc. exercise care to avoid holding the following sections when handling the modules:
 - Exposed area of the printed circuit board
 - Terminal electrode sections