

**LCD MODULE**

MODULE NO. :

**KSEGB12864XXX-05-SERIES****Customer:**

Approved by:

Approved by	Checked by	Prepared by



**CONTENTS**

**1. MODULE CLASSIFICATION INFORMATION ..... 2**

**2. FUNCTIONS & FEATURES ..... 3**

**3. MODULE ARTWORK .....3**

**4. EXTERNAL DIMENSIONS ..... 4**

**5. BLOCK DIAGRAM ..... 5**

**6. PIN ASSIGNMENT ..... 5**

**7. BACKLIGHT ELECTRICAL/OPTICAL SPECIFICATIONS ..... 6**

**8. ABSOLUTE MAXIMUM RATINGS .....6**

**9. ELECTRICAL CHARACTERISTICS ..... 6**

**10. COMMAND DEFINITIONS ..... 9**

**11. OPTICAL CHARACTERISTICS ..... 10**

**12. MODULE ACCEPT QUALITY LEVEL (AQL) .....12**

**13. RELIABILITY TEST ..... 12**

**14. INSPECTION SPECIFICATION .....13**

**15. LCD MODULES HANDLING PRECAUTIONS .....16**

**16. OTHERS ..... 16**

**1. MODULE CLASSIFICATION INFORMATION****KSE G B 12864 - XXX - 05 - V**

①      ②      ③      ④                      ⑤ ⑥ ⑦      ⑧      ⑨

① KSE: KEEN SIDE electronics

② C: Character Type, G: Graphic Type

③ B: COB, G: COG

④ Display Font: 128 \* 64

⑤ LCD Mode:      B→ STN-Blue Negative      F→ FSTN Positive  
                            G→ STN Gray Positive      Y→ STN Yellow Green Positive⑥ Backlight Type: N→ Without backlight      A→ Amber LED backlight  
                            B→ Blue LED backlight      G→ Green LED backlight  
                            R→ Red LED backlight      W→ Withe LED backlight  
                            Y→ Yellow-Green LED backlight⑦ LCD Polarizer Type/Temperature range/View direction :  
                            D→ Transflective, W.T, 12:00      E→ Transmissive, W.T, 6:00  
                            P→ Reflective, W. T, 6:00      Q→ Transmissive, W.T, 12:00  
                            Z→ Transflective, W.T, 6:00

⑧ Model serials no. :

⑨ Special Code: V : Built in negative voltage&amp; Temperature Compensation

**2. FUNCTIONS & FEATURES**

- KSEGB12864XXX-05 SERIES TYPE:
- Viewing Direction : 6 O'clock or 12 O'clock
- Driving Scheme : 1/64Duty, 1/9 Bias
- Power Supply for logic : 5.0V
- Backlight Color : X X X
- Display Content : 128\*64 Dots
- $V_{LCD}$  : 9.0V
- Operation temperature : -20°C to +70°C
- Storage temperature : -30°C to +80°C

**3. MODULE ARTWORK**

- Module Size : 78.0(L)\*70.0 (W)\*12.5(H)mm
- Viewing Area : 62.0(L)mm\*44.0 (W)mm
- Active Area : 56.28(L)mm\*38.36(W)mm
- Dot Pitch : 0.44 (W)mm\*0.60 (H)mm
- Dot Size : 0.4 (W)mm\*0.56(H)mm
- Dot Gap : 0.05 mm

4. EXTERNAL DIMENSIONS

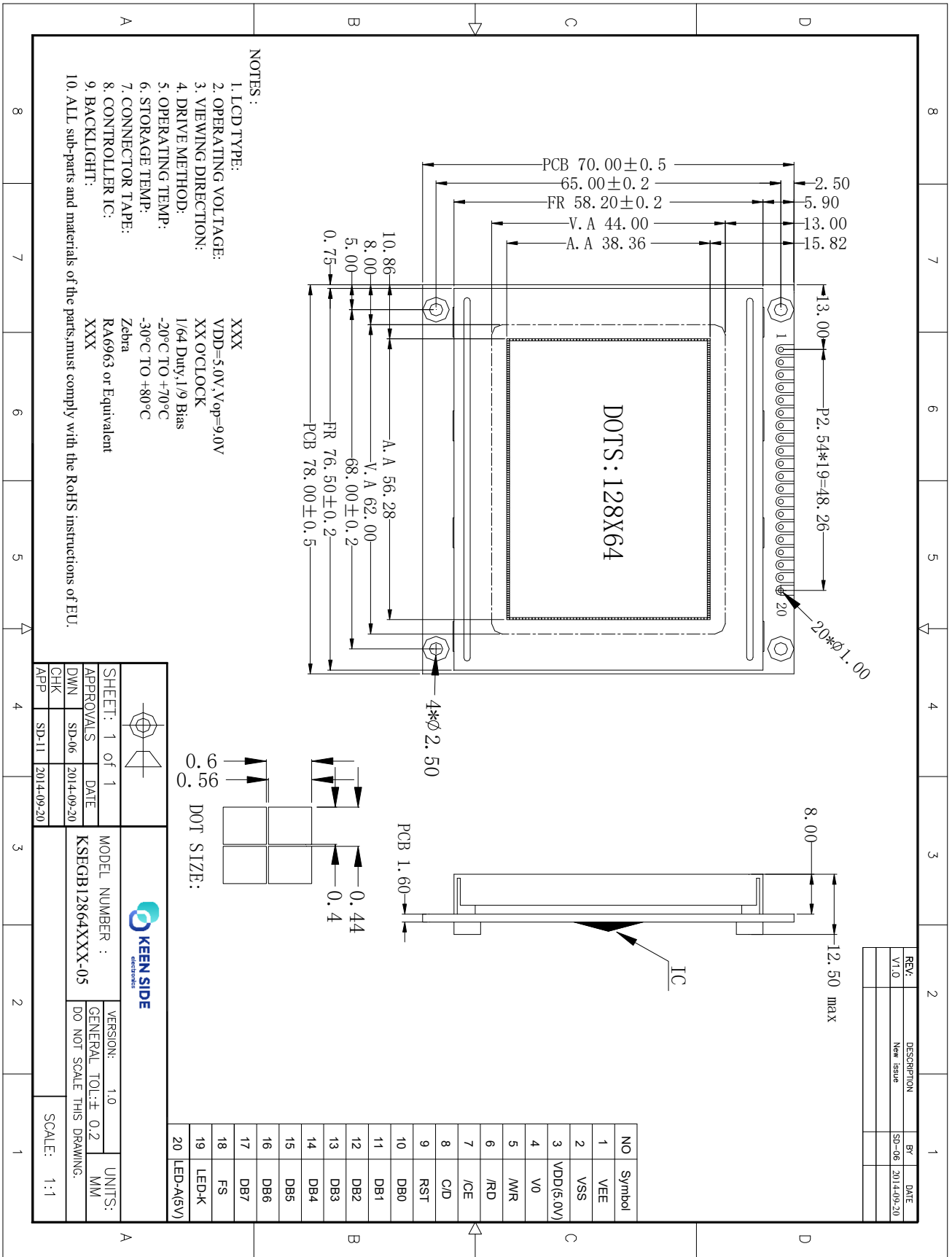

**5. BLOCK DIAGRAM**

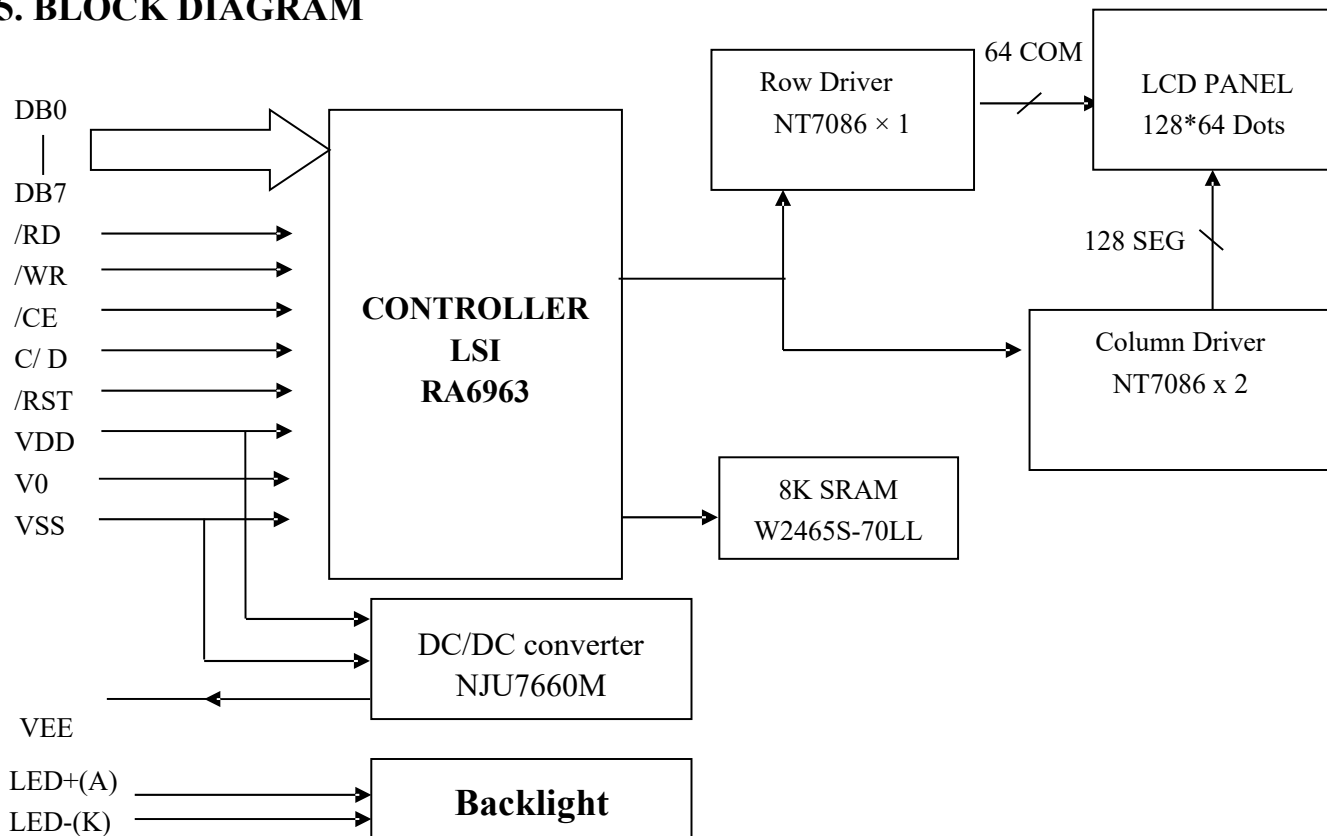

**6. PIN ASSIGNMENT**

NO.	SYMBOL	FUNCTION
1	V E E	Ground (0V)
2	VSS	Ground (0V)
3	VDD	Power Supply(+5V)
4	V0	Power Supply for LCD Drive
5	/WR	Data write. Write data to controller T6963C when “L”
6	/RD	Data read. Read data from controller T6963C when “L”
7	/CE	Chip enable of controller when “L”
8	C/ D	Command/Data read/write. “H” for command read/write and “L” for data read/write
9	/RST	Controller reset when “L”
10	DB0	Data input/output(LSB)
11	DB1	Data input/output
12	DB2	Data input/output
13	DB3	Data input/output
14	DB4	Data input/output
15	DB5	Data input/output
16	DB6	Data input/output
17	DB7	Data input/output(MSB)
18	FS	Font select. “H” for 6x8 font & “L” for 8x8 font
19	LED-(K)	Cathode of LED backlight
20	LED+(A)	Anode of LED backlight (5.0V)

## 7. BACKLIGHT ELECTRICAL/OPTICAL SPECIFICATIONS

ITEM	SYMBOL	MIN.	TYP.	MAX.	UNIT	CONDITIONS
Forward Voltage	V <sub>f</sub>	4.8	5.0	5.2	V	I <sub>f</sub> = 15x4 mA
Reverse Current	I <sub>r</sub>			100	μA	V <sub>r</sub> =5.0 V
Dominant wave length	X	0.28		0.30		I <sub>f</sub> = 15x4 mA
	Y	0.28		0.30	-	
Spectral Line Half width	Δ λ		--		nm	I <sub>f</sub> = 15x4 mA
Luminous	L <sub>v</sub>	70	80		cd/m <sup>2</sup>	I <sub>f</sub> = 15x4 mA

## 8. ABSOLUTE MAXIMUM RATINGS

PARAMETER	SYMBOL	RATING	UNIT
Supply Voltage (Logic)	V <sub>DD</sub>	-0.3 to 7.0	V
Input voltage	V <sub>IN</sub>	-0.3 to V <sub>DD</sub> +0.3	V
Operating Temperature	T <sub>opr</sub>	-20 to +70	°C
Storage Temperature	T <sub>stg</sub>	-25 to +75	°C

## 9. ELECTRICAL CHARACTERISTICS

### 1). DC Characteristics

Parameter	Symbol	Conditions	Min.	Typ.	Max.	Units
Supply Voltage (Logic)	V <sub>DD</sub> -V <sub>SS</sub>	-	4.5	5.0	5.5	V
High Level Input Voltage	V <sub>IH</sub>	V <sub>DD</sub> =5.0V±10%	V <sub>DD</sub> -2.2	-	V <sub>DD</sub>	V
Low Level Input Voltage	V <sub>IL</sub>	V <sub>DD</sub> =5.0V±10%	0	-	0.8	V
High Level Output Voltage	V <sub>OH</sub>	I <sub>OH</sub> =0.75mA	V <sub>DD</sub> -0.3	-	V <sub>DD</sub>	V
Low Level Output Voltage	V <sub>OL</sub>	I <sub>OL</sub> =0.75mA	0	-	0.3	V
Current Consumption(Operating)	I <sub>DD(1)</sub>	V <sub>DD</sub> =5.0V f <sub>OSC</sub> = 3.0 MHz	-	3.3	6.0	mA

### 2). AC Characteristics

Parameter	Symbol	Min.	Max.	Units
C/D Setup Time	t <sub>CDS</sub>	100	-	ns
C/D Hold Time	t <sub>CDH</sub>	10	-	ns
CE, RD, WR Pulse Width	t <sub>CE</sub> , t <sub>RD</sub> , t <sub>WR</sub>	80	-	ns
Data Setup Time	t <sub>DS</sub>	80	-	ns
Data Hold Time	t <sub>DH</sub>	40	-	ns
Access Time	t <sub>ACC</sub>	-	150	ns
Output Hold Time	t <sub>OH</sub>	10	50	ns



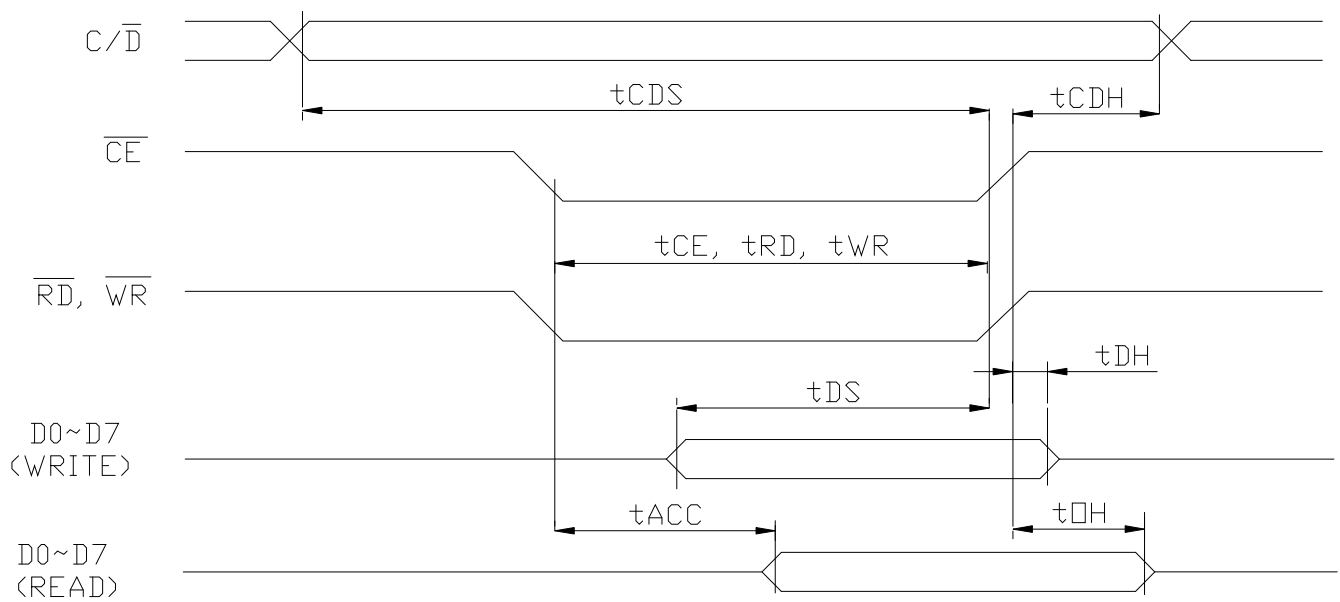

**3). Power Supply ON/OFF Sequence**

● ON Sequence

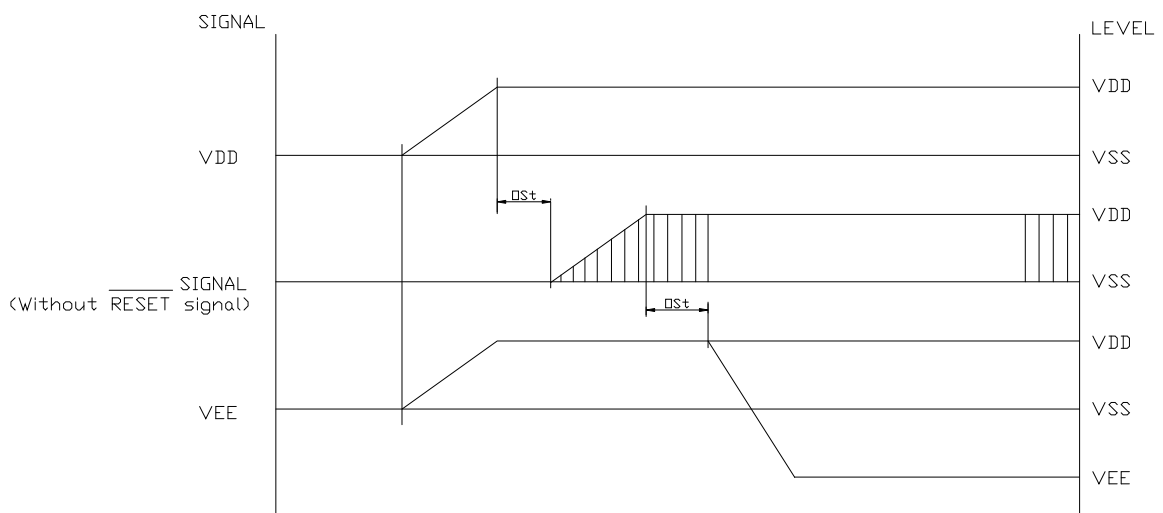

● **OFF Sequence**

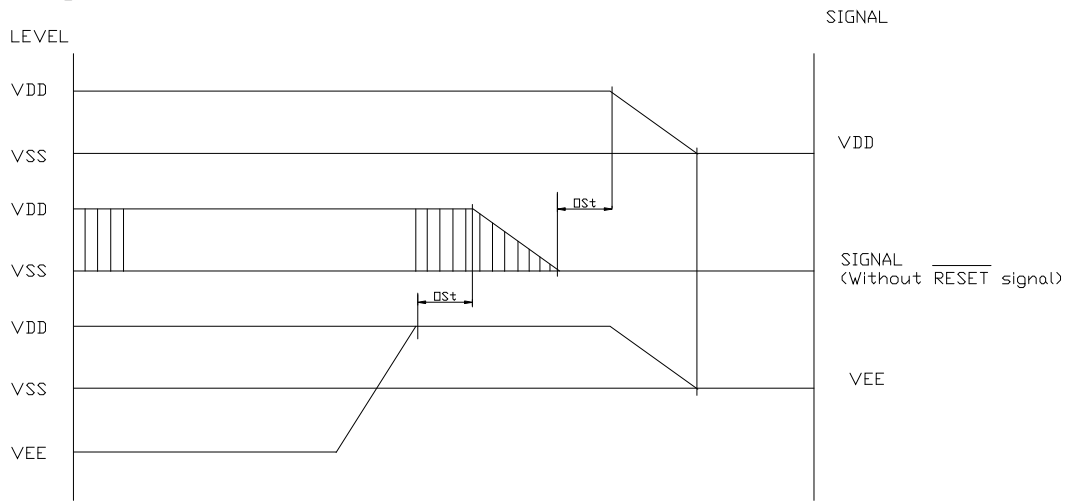

● **Reset Sequence**

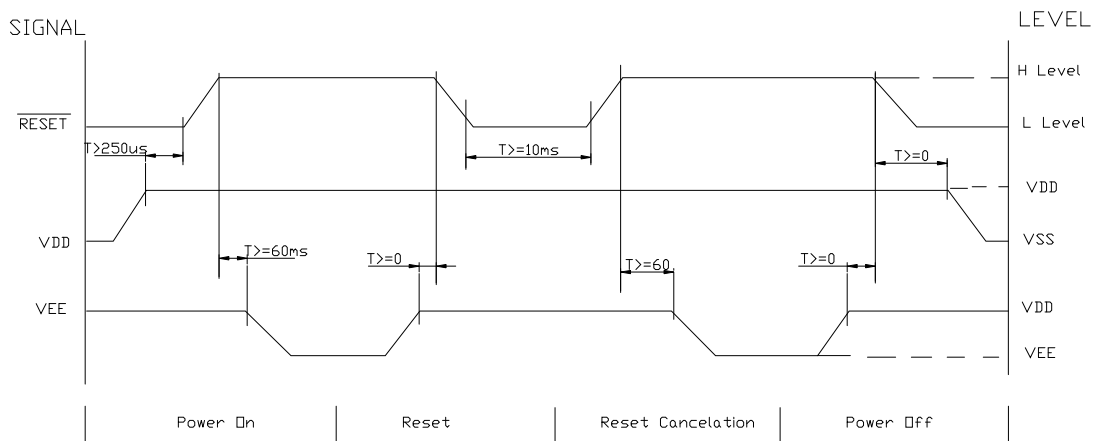

Please maintain the above sequence when turning on and off the power supply of the module.

If VEE is supplied to the module while internal alternate signal for LCD driving (M) is unstable or RESET is active, DC component will be supplied to the LCD panel. This may cause damage to the LCD module.

**10. COMMAND DEFINITIONS**

Command	Code	D1	D2	Function
REGISTERS SETTING	00100001 00100010 00100100	X address Data Low address	Y address 00H High address	Set Cursor Pointer Set Offset Register Set Address Pointer
SET CONTROL WORD	01000000 01000001 01000010 01000011	Low address Columns Low address Columns	High address 00H High address 00H	Set Text Home Address Set Text Area Set Graphic Home Address Set Graphic Area
MODE SET	1000X000 1000X001 1000X011 1000X100 10000XXX 10001XXX	— — — — — —	— — — — — —	OR mode EXOR mode AND mode Text Attribute mode Internal CG ROM mode External CG RAM mode
DISPLAY MODE	10010000 1001XX10 1001XX11 100101XX 100110XX 100111XX	— — — — — —	— — — — — —	Display off Cursor on, blink off Cursor on, blink on Text on, graphic off Text off, graphic on Text on, graphic on
CURSOR PATTERN SELECT	10100000 10100001 10100010 10100011 10100100 10100101 10100110 10100111	— — — — — — — —	— — — — — — — —	1-line cursor 2-line cursor 3-line cursor 4-line cursor 5-line cursor 6-line cursor 7-line cursor 8-line cursor
DATA AUTO READ / WRITE	10110000 10110001 10110010	— — —	— — —	Set Data Auto Write Set Data Auto Read Auto Reset
DATA READ / WRITE	11000000 11000001 11000010 11000011 11000100 11000101	Data — Data — Data —	— — — — — —	Data Write and Increment ADP Data Read and Increment ADP Data Write and Decrement ADP Data Read and Decrement ADP Data Write and Nonvariable ADP Data Read and Nonvariable ADP
SCREEN PEEK	11100000	—	—	Screen Peek
SCREEN COPY	11101000			Screen Copy

## 11. OPTICAL CHARACTERISTICS

### 11.1 Definition of Viewing Angle

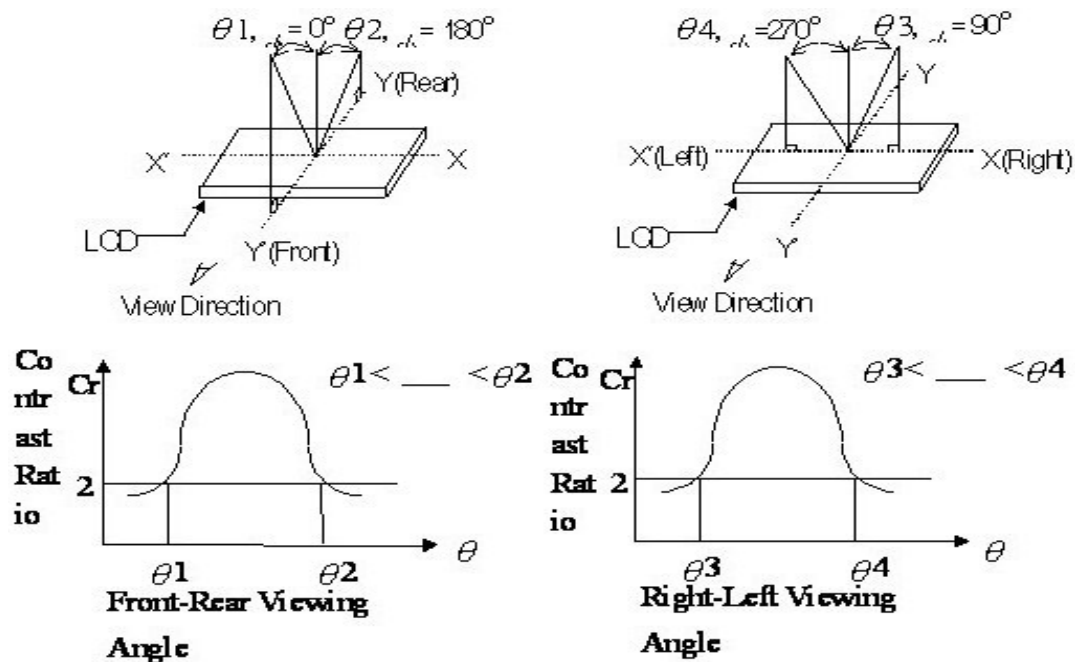

### 11.2 Definition of Contrast

$$\text{C.R} = \frac{\text{Brightness of nonselected segment (E2)}}{\text{Brightness of selected segment}}$$

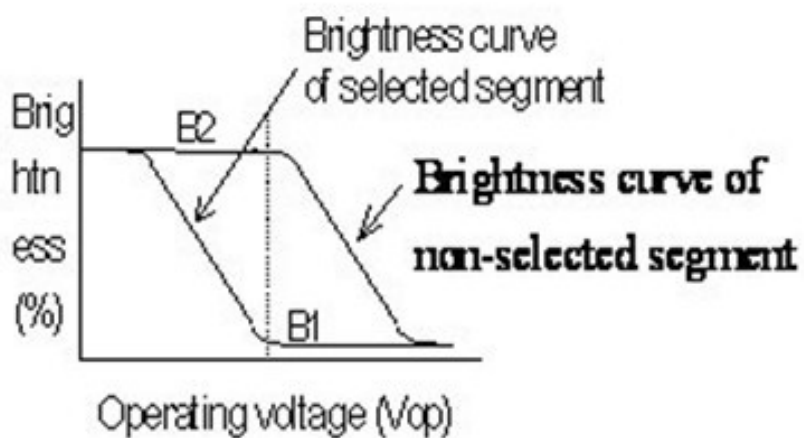

**11.3 Definition of Response**

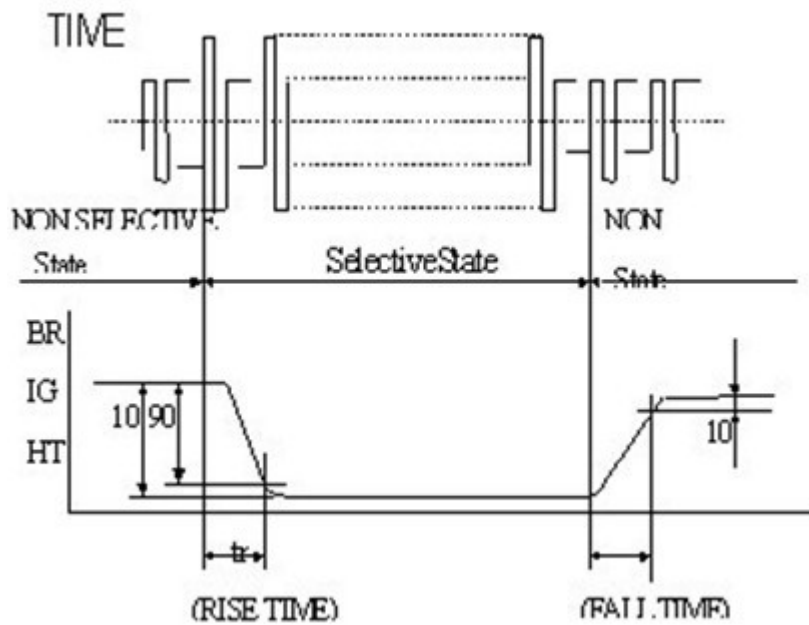

**11.4 Measuring Instruments For Elector-optical Characteristics**

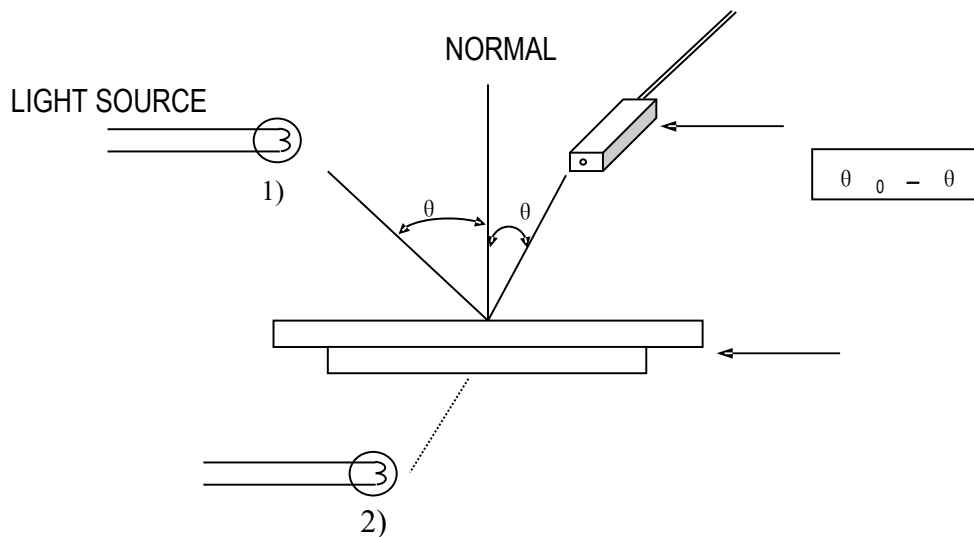

**\* Note:**

- 1) Light source position for measuring the reflective type of LCD panel;
- 2) Light source position for measuring the transfective / transmissive types of LCD panel.

**12. MODULE ACCEPT QUALITY LEVEL (AQL)**

12.1 AQL Standard Value: Critical Defect =0.1, Major Defect=0.65; Minor Defect =2.5.

12.2 Inspection Standard: MIL-STD-105E Table Normal Inspection Single Sampling Level II

**13. RELIABILITY TEST**

Operating life time: Longer than 75,000 hours

(at room temperature without direct irradiation of sunlight)

Reliability characteristics shall meet following requirements.

No.	Test Item	Content of Test	Test Condition
1	High Temperature Storage	Endurance test applying the high temperature for a long time storage	+80°C 96H
2	Low Temperature Storage	Endurance test applying the low temperature for a long time storage	-30°C 96H
3	High Temperature Operation	Endurance test applying the electric stress (voltage & current) and the thermal stress to the element for a long time	+70°C 96H
4	Low Temperature Operation	Endurance test applying the electric stress under low temperature for a long time	-20°C 96H
5	High Temperature/ Humidity Storage	Endurance test applying the high temperature and humidity storage for a long time	40°C 90%RH 96H
6	Temperature Cycle	Endurance test applying the low and high temperature cycle $  \begin{array}{ccccccc}  -20^{\circ}\text{C} & \longleftrightarrow & 25^{\circ}\text{C} & \longleftrightarrow & 70^{\circ}\text{C} & \longleftrightarrow & 25^{\circ}\text{C} \\  30\text{min} & & 5\text{min} & & 30\text{min} & & 5\text{min} \\  \longleftarrow & & & & & & \longrightarrow \\  & & & & & & \text{1 cycle}  \end{array}  $	-20°C/70°C 5 cycles
7	Vibration Test (Package State)	Endurance test applying the vibration during transportation	10Hz - 55Hz, 50m/s, 15min
8	Shock Test (Package State)	Endurance test applying the shock during transportation	Half-sinewave, 100m/s, 11ms
9	Atmospheric Pressure Test	Endurance test applying the atmospheric pressure during transportation by air	40 kPa 16 H

**14. Inspection specification**

**14.1 Visual Inspection**

- 1) Inspect under 2x20W or 40W fluorescent lamp (approximately 3000 lux) leaving 25 to 30 cm between the module and the lamp and 30 cm between the module and the eye (measuring position).
- 2) Appearance is inspected at the best contrast voltage (best contrast is adjusted considering clearness and crosstalk on screen).
- 3) Inspect the module at 45° right and left, top and bottom.
- 4) Use the optimum viewing angle during the contrast inspection.

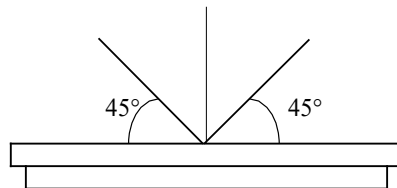

**14.2 Standard of Appearance Inspection**

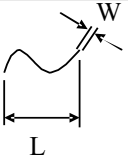
No.	Item	Criteria																			
1	Black spot White spot Dust	Round type: as per following drawing $\Phi = (X+Y)/2$  <table border="1" style="margin-left: 20px;"> <thead> <tr> <th colspan="3">Acceptable quantity</th> </tr> <tr> <th>Size</th> <th>Zone A</th> <th>Zone B</th> </tr> </thead> <tbody> <tr> <td><math>\Phi &lt; 0.1</math></td> <td>Any number</td> <td rowspan="4">Any number</td> </tr> <tr> <td><math>0.1 &lt; \Phi &lt; 0.2</math></td> <td>2</td> </tr> <tr> <td><math>0.2 &lt; \Phi &lt; 0.25</math></td> <td>1</td> </tr> <tr> <td><math>0.25 &lt; \Phi</math></td> <td>0</td> </tr> </tbody> </table>	Acceptable quantity			Size	Zone A	Zone B	$\Phi < 0.1$	Any number	Any number	$0.1 < \Phi < 0.2$	2	$0.2 < \Phi < 0.25$	1	$0.25 < \Phi$	0				
		Acceptable quantity																			
Size	Zone A	Zone B																			
$\Phi < 0.1$	Any number	Any number																			
$0.1 < \Phi < 0.2$	2																				
$0.2 < \Phi < 0.25$	1																				
$0.25 < \Phi$	0																				
Line type: as per following drawing <table border="1" style="margin-left: 20px;"> <thead> <tr> <th colspan="4">Acceptable quantity</th> </tr> <tr> <th>Length</th> <th>Width</th> <th>Zone A</th> <th>Zone B</th> </tr> </thead> <tbody> <tr> <td>—</td> <td><math>W \leq 0.02</math></td> <td>Any number</td> <td rowspan="4">Any number</td> </tr> <tr> <td><math>L \leq 3.0</math></td> <td><math>0.02 &lt; W \leq 0.03</math></td> <td>2</td> </tr> <tr> <td><math>L \leq 2.5</math></td> <td><math>0.03 &lt; W \leq 0.05</math></td> <td>2</td> </tr> <tr> <td>—</td> <td><math>0.05 &lt; W</math></td> <td>As round type</td> </tr> </tbody> </table>  <p style="margin-left: 20px;">Total acceptable quantity: 3</p>	Acceptable quantity				Length	Width	Zone A	Zone B	—	$W \leq 0.02$	Any number	Any number	$L \leq 3.0$	$0.02 < W \leq 0.03$	2	$L \leq 2.5$	$0.03 < W \leq 0.05$	2	—	$0.05 < W$	As round type
Acceptable quantity																					
Length	Width	Zone A	Zone B																		
—	$W \leq 0.02$	Any number	Any number																		
$L \leq 3.0$	$0.02 < W \leq 0.03$	2																			
$L \leq 2.5$	$0.03 < W \leq 0.05$	2																			
—	$0.05 < W$	As round type																			
2	Polariser scratch	Scratch on protective film is permitted Scratch on polariser: same as No. 1																			
3	Polariser bubble	$\Phi = (X+Y)/2$																			

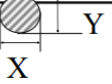
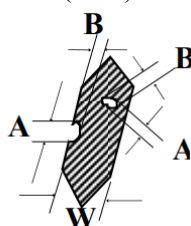
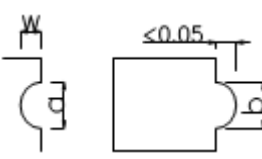
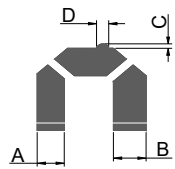
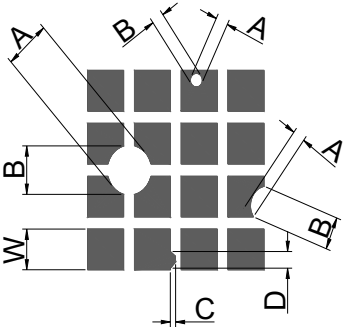
		 <table border="1" data-bbox="766 197 1428 459"> <thead> <tr> <th colspan="3">Acceptable quantity</th> </tr> <tr> <th>Size</th> <th>Zone A</th> <th>Zone B</th> </tr> </thead> <tbody> <tr> <td><math>\Phi &lt; 0.2</math></td> <td>Any number</td> <td rowspan="4">Any number</td> </tr> <tr> <td><math>0.2 &lt; \Phi &lt; 0.5</math></td> <td>2</td> </tr> <tr> <td><math>0.5 &lt; \Phi &lt; 1.0</math></td> <td>1</td> </tr> <tr> <td><math>1.0 &lt; \Phi</math></td> <td>0</td> </tr> </tbody> </table> <p>Total acceptable quantity: 3</p>	Acceptable quantity			Size	Zone A	Zone B	$\Phi < 0.2$	Any number	Any number	$0.2 < \Phi < 0.5$	2	$0.5 < \Phi < 1.0$	1	$1.0 < \Phi$	0																					
Acceptable quantity																																						
Size	Zone A	Zone B																																				
$\Phi < 0.2$	Any number	Any number																																				
$0.2 < \Phi < 0.5$	2																																					
$0.5 < \Phi < 1.0$	1																																					
$1.0 < \Phi$	0																																					
4	Segment deformation	<p>4.1 Pin hole on segmented display  W: segment width  <math>\Phi = (A+B)/2</math></p>  <table border="1" data-bbox="837 627 1428 952"> <thead> <tr> <th colspan="2">Acceptable quantity</th> </tr> <tr> <th>Width</th> <th>Quantity</th> </tr> </thead> <tbody> <tr> <td><math>W \leq 0.4</math></td> <td><math>\Phi \leq 0.2</math> and <math>\Phi \leq 1/2W</math></td> </tr> <tr> <td><math>W &gt; 0.4</math></td> <td><math>\Phi \leq 0.25</math> and <math>\Phi \leq 1/3W</math></td> </tr> </tbody> </table> <p>Total acceptable quantity: 1 defect per segment  Pin holes with <math>\Phi</math> under 0.10 mm are acceptable</p> <p>4.2 Pin hole on dot matrix display</p>  <table border="1" data-bbox="981 1019 1428 1232"> <thead> <tr> <th colspan="2">Acceptable quantity</th> </tr> <tr> <th>Size</th> <th>Quantity</th> </tr> </thead> <tbody> <tr> <td><math>a, b &lt; 0.1</math></td> <td>Any number</td> </tr> <tr> <td><math>(a+b)/2 \leq 0.1</math></td> <td>Any number</td> </tr> <tr> <td><math>0.5 &lt; \Phi &lt; 1.0</math></td> <td>3</td> </tr> </tbody> </table> <p>Total acceptable quantity: 7</p> <p>4.3 Segments / dots with different width</p>  <table border="1" data-bbox="981 1377 1340 1489"> <thead> <tr> <th colspan="2">Acceptable</th> </tr> </thead> <tbody> <tr> <td><math>a \geq b</math></td> <td><math>a/b \leq 4/3</math></td> </tr> <tr> <td><math>a &lt; b</math></td> <td><math>a/b &gt; 4/3</math></td> </tr> </tbody> </table> <p>4.4 Alignment layer defect  <math>\Phi = (A+B)/2</math></p>  <table border="1" data-bbox="989 1680 1428 1993"> <thead> <tr> <th colspan="2">Acceptable quantity</th> </tr> <tr> <th>Size</th> <th>Quantity</th> </tr> </thead> <tbody> <tr> <td><math>\Phi \leq 0.4</math></td> <td>Any number</td> </tr> <tr> <td><math>0.4 &lt; \Phi \leq 1.0</math></td> <td>5</td> </tr> <tr> <td><math>1.0 &lt; \Phi \leq 1.5</math></td> <td>3</td> </tr> <tr> <td><math>1.5 &lt; \Phi \leq 2.0</math></td> <td>2</td> </tr> </tbody> </table> <p>Total acceptable quantity: 7</p>	Acceptable quantity		Width	Quantity	$W \leq 0.4$	$\Phi \leq 0.2$ and $\Phi \leq 1/2W$	$W > 0.4$	$\Phi \leq 0.25$ and $\Phi \leq 1/3W$	Acceptable quantity		Size	Quantity	$a, b < 0.1$	Any number	$(a+b)/2 \leq 0.1$	Any number	$0.5 < \Phi < 1.0$	3	Acceptable		$a \geq b$	$a/b \leq 4/3$	$a < b$	$a/b > 4/3$	Acceptable quantity		Size	Quantity	$\Phi \leq 0.4$	Any number	$0.4 < \Phi \leq 1.0$	5	$1.0 < \Phi \leq 1.5$	3	$1.5 < \Phi \leq 2.0$	2
Acceptable quantity																																						
Width	Quantity																																					
$W \leq 0.4$	$\Phi \leq 0.2$ and $\Phi \leq 1/2W$																																					
$W > 0.4$	$\Phi \leq 0.25$ and $\Phi \leq 1/3W$																																					
Acceptable quantity																																						
Size	Quantity																																					
$a, b < 0.1$	Any number																																					
$(a+b)/2 \leq 0.1$	Any number																																					
$0.5 < \Phi < 1.0$	3																																					
Acceptable																																						
$a \geq b$	$a/b \leq 4/3$																																					
$a < b$	$a/b > 4/3$																																					
Acceptable quantity																																						
Size	Quantity																																					
$\Phi \leq 0.4$	Any number																																					
$0.4 < \Phi \leq 1.0$	5																																					
$1.0 < \Phi \leq 1.5$	3																																					
$1.5 < \Phi \leq 2.0$	2																																					
5	Colour	Level of sample for approval set as limit sample																																				



uniformity				
6	Backlight	The backlight colour should correspond to the product specification Flashing and or unlit backlight is not allowed Dust larger than 0.25 mm is not allowed		
7	COB	Exposed wire bond pad is not allowed Insufficient covering with resin is not allowed (wire bond line exposed) Dust or bubble on the resin are not allowed		
8	PCB	No unmelted solder paste should be present on PCB Cold solder joints, missing solder connections, or oxidation are not allowed No residue or solder balls on PCB are allowed Short circuits on components are not allowed		
9	Tray particles	Acceptable quantity		
			Size	Quantity
		On tray	$\Phi < 0.2$	Any number
			$\Phi > 0.25$	4
On display	$\Phi \geq 0.25$	2		
	L = 3	1		

**15. LCD MODULES HANDLING PRECAUTIONS**

- Please remove the protection foil of polarizer before using.
- The display panel is made of glass. Do not subject it to a mechanical shock by dropping it from a high place, etc.
- If the display panel is damaged and the liquid crystal substance inside it leaks out, do not get any in your mouth. If the substance come into contact with your skin or clothes promptly wash it off using soap and water.
- Do not apply excessive force to the display surface or the adjoining areas since this may cause the color tone to vary.
- The polarizer covering the display surface of the LCD module is soft and easily scratched. Handle this polarize carefully.
- To prevent destruction of the elements by static electricity, be careful to maintain an optimum work environment.
  - Be sure to ground the body when handling the LCD module.
  - Tools required for assembly, such as soldering irons, must be properly grounded.
  - To reduce the amount of static electricity generated, do not conduct assembly and other work under dry conditions.
  - The LCD module is coated with a film to protect the display surface. Exercise care when peeling off this protective film since static electricity may be generated.
- Storage precautions  
When storing the LCD modules, avoid exposure to direct sunlight or to the light of fluorescent lamps. Keep the modules in bags designed to prevent static electricity charging under low temperature / normal humidity conditions (avoid high temperature / high humidity and low temperatures below 0°C). Whenever possible, the LCD modules should be stored in the same conditions in which they were shipped from our company.

**16. OTHERS**

- Liquid crystals solidify at low temperature (below the storage temperature range) leading to defective orientation of liquid crystal or the generation of air bubbles (black or white). Air bubbles may also be generated if the module is subjected to a strong shock at a low temperature.
- If the LCD modules have been operating for a long time showing the same display patterns may remain on the screen as ghost images and a slight contrast irregularity may also appear. Abnormal operating status can be resumed to be normal condition by suspending use for some time. It should be noted that this phenomena does not adversely affect performance reliability.
- To minimize the performance degradation of the LCD modules resulting from caused by static electricity, etc. exercise care to avoid holding the following sections when handling the modules:
  - Exposed area of the printed circuit board
  - Terminal electrode sections