

NOTES:

1. ALL PARTS TO BE BULK PACKED
2. CONTACTS ARE INSTALLED INTO CONNECTOR.

ASS'Y P/N	NO. OF CONTACT	CABLE O.D.
18282-2PG-311	2 POS.	.09-.14 [2.3-3.5mm]
18282-2PG-315		.15-.17 [3.8-4.3mm]
18282-2PG-318		.18-.20 [4.6-5.1mm]
18282-3PG-311	3 POS.	.09-.14 [2.3-3.5mm]
18282-3PG-315		.15-.17 [3.8-4.3mm]
18282-3PG-318		.18-.20 [4.6-5.1mm]

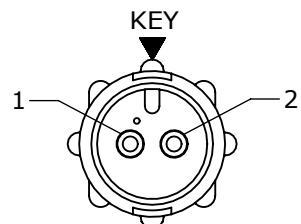

**FACE VIEW**  
18282-2PG-3XX

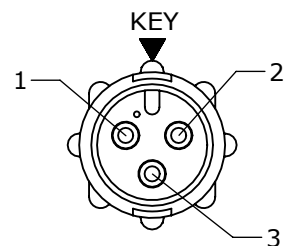

**FACE VIEW**  
18282-3PG-3XX

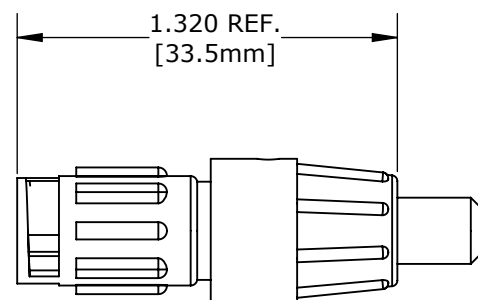
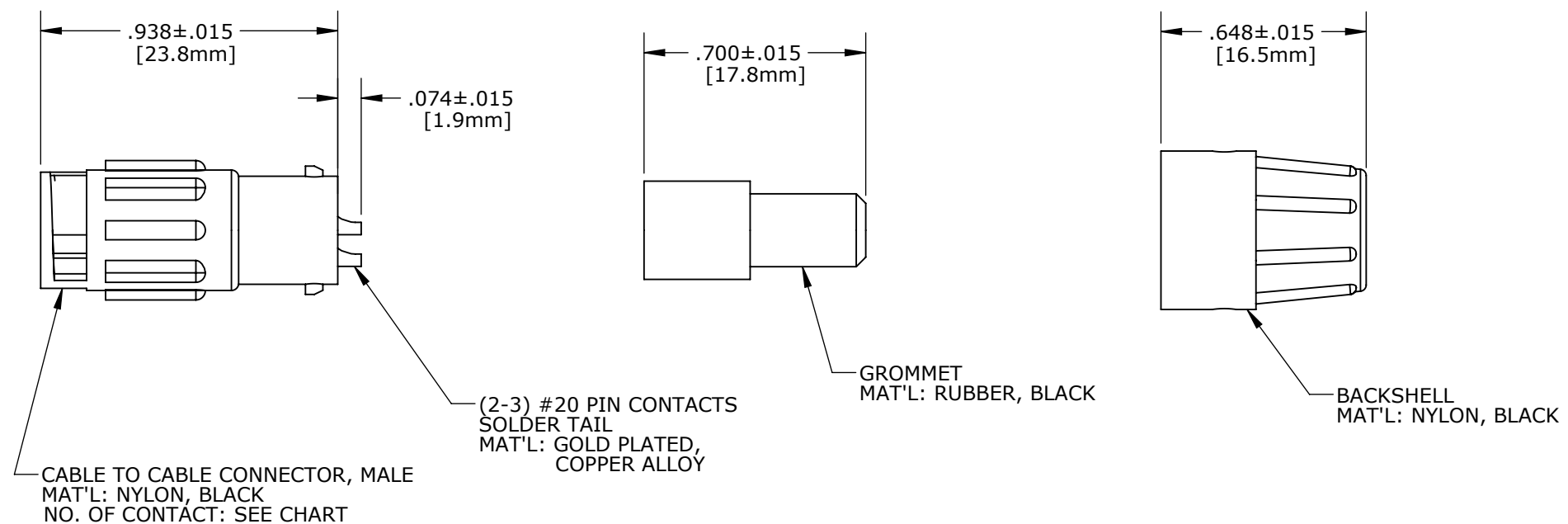

**SHOWN ASSEMBLED KIT**  
FOR CUSTOMER REFERENCE ONLY

DIMENSIONS IN BRACKET [ ] ARE METRIC.

**CUSTOMER APPROVAL**

THIS DOCUMENT CONTAINS CONFIDENTIAL INFORMATION PROPRIETARY TO CONXALL CORPORATION. ANY REPRODUCTION, DISCLOSURE, OR USE OF THIS DOCUMENT /INFORMATION IS EXPRESSLY PROHIBITED UNLESS AUTHORIZED IN WRITING BY CONXALL CORPORATION.

APPROVED BY: \_\_\_\_\_  
DATE: \_\_\_\_\_

**RoHS COMPLIANT**

A	AN	11-08-11	DRAWING CREATED PER DOR 11-E149SL	
REV.	INIT.	DATE	DESCRIPTION	
	AN	11-07-11	ALL INFORMATION ILLUSTRATED IS THE PROPERTY OF CONXALL CORPORATION. UNAUTHORIZED DUPLICATION OR DISTRIBUTION OF THIS DOCUMENT IS PROHIBITED.	
ALL UNITS ARE IN FEET, INCHES, FRACTION OF INCHES AND DECIMALS. UNLESS OTHERWISE SPECIFIED TOLERANCES: 3 PLACE DECIMALS ±.010 ANGLES ±1° FRACTIONS ±1/16 - CRITICAL CHARACTERISTIC FLAG PER SPEC. XXXX			ORG. DRAWN BY: AN DATE: 11-07-11 CHECKED BY: APPROVED BY:	 601 E. WILDWOOD VILLA PARK, IL 60181 TITLE: CABLE TO CABLE CONN. ASS'Y (2-3) #20 PIN CONTACTS, SOLDER MINI-CON-X CUSTOMER: STANDARD PRODUCT
SCALE	SIZE	SHEET		
NTS	B	1 OF 1		
FILE:	DIRECTORY:	PART NUMBER:	REV	
18282-XPG-3XX	SLW	18282-XPG-3XX	A	

# Mouser Electronics

Authorized Distributor

Click to View Pricing, Inventory, Delivery & Lifecycle Information:

[Switchcraft:](#)

[18282-3PG-318](#)