

San Ace 92 9HV type

High Static Pressure Fan

Features

High Static Pressure and High Airflow

This fan delivers a maximum static pressure of 280 Pa, and a maximum airflow of 3.35 m³/min.*

Compared with the current model,** the maximum static pressure has increased by 2.7 times and maximum airflow has increased by 1.5 times.

High Energy Efficiency and Low Noise

The PWM control function enables the control of fan speed, contributing to lowering noise and improving energy efficiency of devices.

* For model no.: 9HV0912P4G001, 9HV0924P4G001

** Current model: San Ace 92 9GA type 92 x 92 x 25 mm DC Fan (model no.: 9GA0912P4J03, 9GA0924P4J03).



Image depicts product without ribs.

92x92x25 mm

Specifications

The models listed below **have ribs and pulse sensors with PWM control function**. For models without ribs, append "1" to the end of model numbers.

Model no.	Rated voltage [V]	Operating voltage range [V]	PWM duty cycle* [%]	Rated current [A]	Rated input [W]	Rated speed [min ⁻¹]	Max. airflow [m ³ /min] [CFM]	Max. static pressure [Pa] [inchH ₂ O]	SPL [dB(A)]	Operating temperature [°C]	Expected life [h]
9HV0912P4G001	12	10.2 to 13.8	100	1.23	14.76	7350	3.35 118	280 1.12	56	-20 to +70	40000/60°C (70000/40°C)
			20	0.12	1.44	2200	1.0 35.3	25 0.1	26		
9HV0912P4H001			100	0.71	8.52	6050	2.75 97.1	190 0.76	52		
			20	0.07	0.84	1700	0.77 27.2	15 0.06	20		
9HV0924P4G001	24	20.4 to 27.6	100	0.61	14.64	7350	3.35 118	280 1.12	56		
			20	0.06	1.44	2200	1.0 35.3	25 0.1	26		
9HV0924P4H001			100	0.38	9.12	6050	2.75 97.1	190 0.76	52		
			20	0.05	1.2	1700	0.77 27.2	15 0.06	20		

* PWM frequency: 25 kHz. Fan does not rotate when PWM duty cycle is 0%.

Models with the following sensor specifications are also available as options: **Without sensor** **Lock sensor**

Common Specifications

- Material Frame: Plastic (Flammability: UL 94V-0), Impeller: Plastic (Flammability: UL 94V-1)
- Expected life Refer to specifications
(L10 life: 90% survival rate for continuous operation in free air at 60°C, rated voltage)
Expected life at 40°C is for reference only.
- Motor protection system Current blocking function and reverse polarity protection
- Dielectric strength 50/60 Hz, 500 VAC, for 1 minute (between lead wire conductors and frame)
- Insulation resistance 10 MΩ or more with a 500 VDC megger (between lead wire conductors and frame)
- Sound pressure level (SPL) At 1 m away from the air inlet
- Operating temperature Refer to specifications (Non-condensing)
- Storage temperature -30 to +70°C (Non-condensing)
- Lead wire ⊕ Red ⊖ Black **Sensor** Yellow **Control** Brown
- Mass 150 g

Airflow - Static Pressure Characteristics

• PWM duty cycle

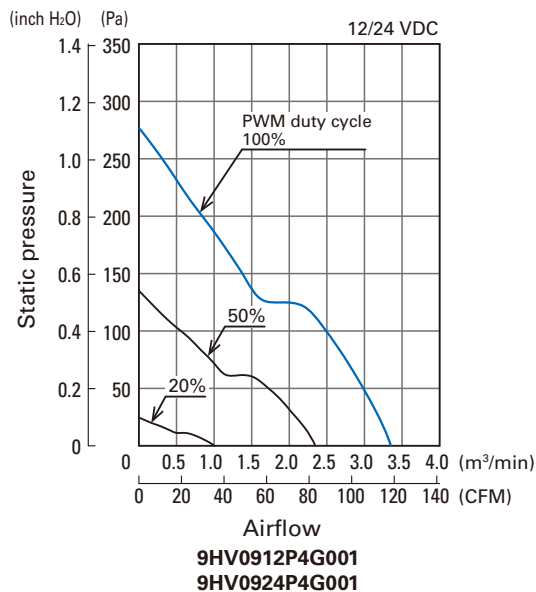

• Operating voltage range

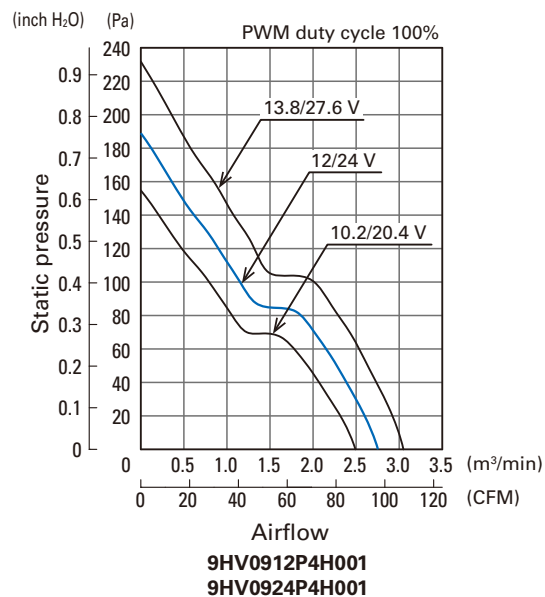
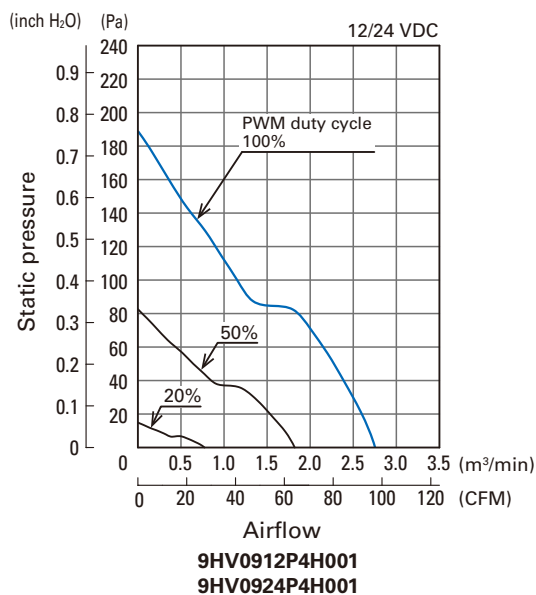
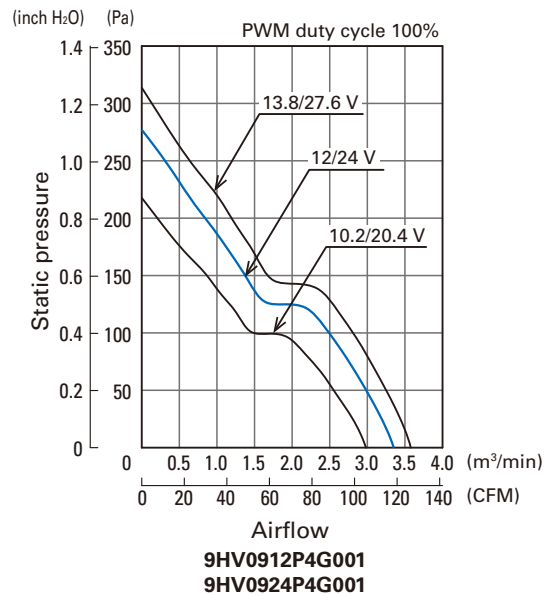

PWM Duty - Speed Characteristics Example

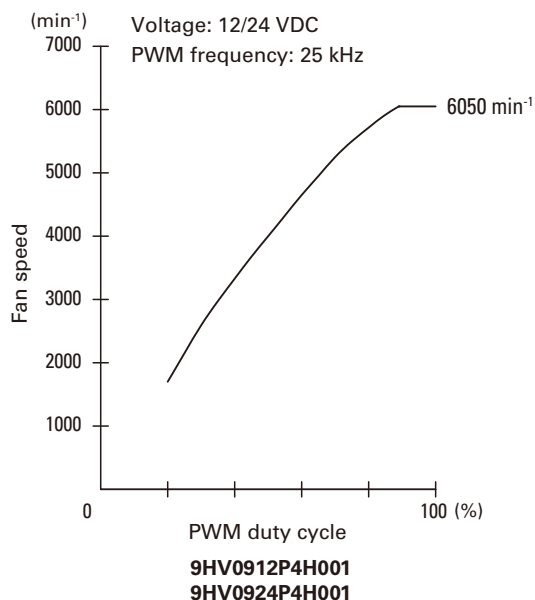
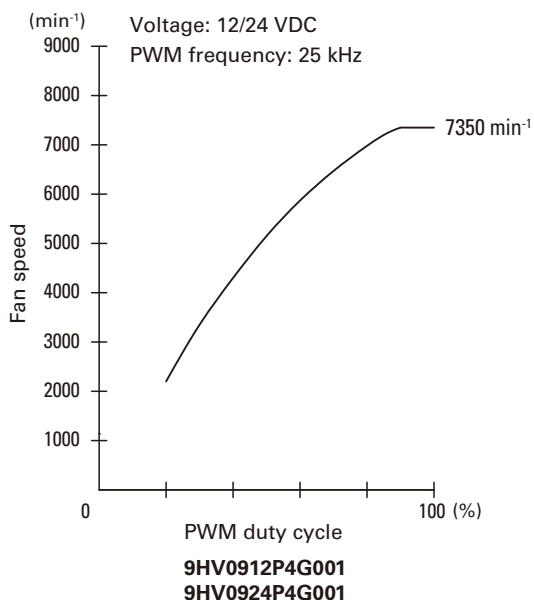

PWM Input Signal Example

Input signal waveform

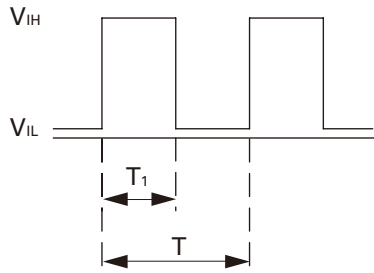

$V_{IH} = 4.75 \text{ to } 5.25 \text{ V}$ $V_{IL} = 0 \text{ to } 0.4 \text{ V}$
 PWM duty cycle (%) = $\frac{T_1}{T} \times 100$ PWM frequency 25 (kHz) = $\frac{1}{T}$
 Current source (I_{source}) = 1 mA max. (when control voltage is 0 V)
 Current sink (I_{sink}) = 1 mA max. (when control voltage is 5.25 V)
 Control terminal voltage = 5.25 V max. (when control terminal is open)

When the control terminal is open,
 fan speed is the same as when PWM duty cycle is 100%.
 Either TTL input, open collector or open drain can be used for
 PWM control input signal.

Example of Connection Schematic

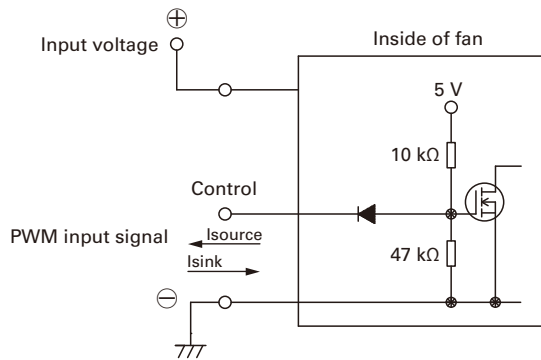

Specifications for Pulse Sensors

Output circuit: Open collector

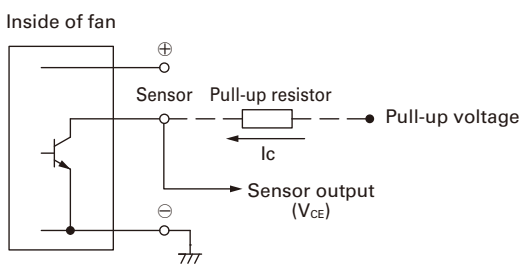

Rated voltage 12 V fan
 $V_{CE} = +13.8 \text{ V max.}$
 $I_c = 5 \text{ mA max. [} V_{OL} = V_{CE} \text{ (SAT)} = 0.6 \text{ V max.]}$

Rated voltage 24 V fan
 $V_{CE} = +27.6 \text{ V max.}$
 $I_c = 5 \text{ mA max. [} V_{OL} = V_{CE} \text{ (SAT)} = 0.6 \text{ V max.]}$

Output waveform (Need pull-up resistor)

In case of steady running

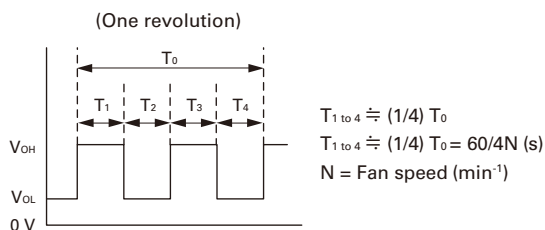

Dimensions (unit: mm)

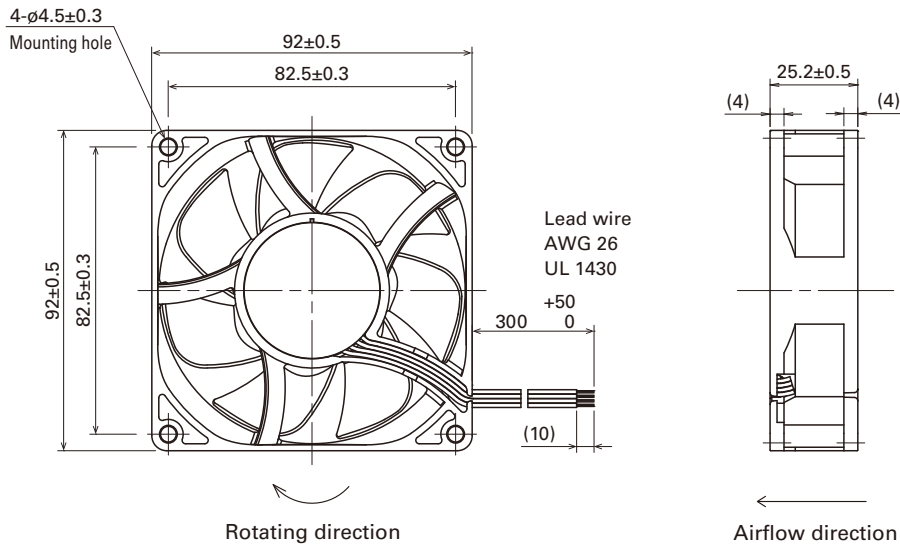

Reference Dimensions of Mounting Holes and Vent Opening (unit: mm)

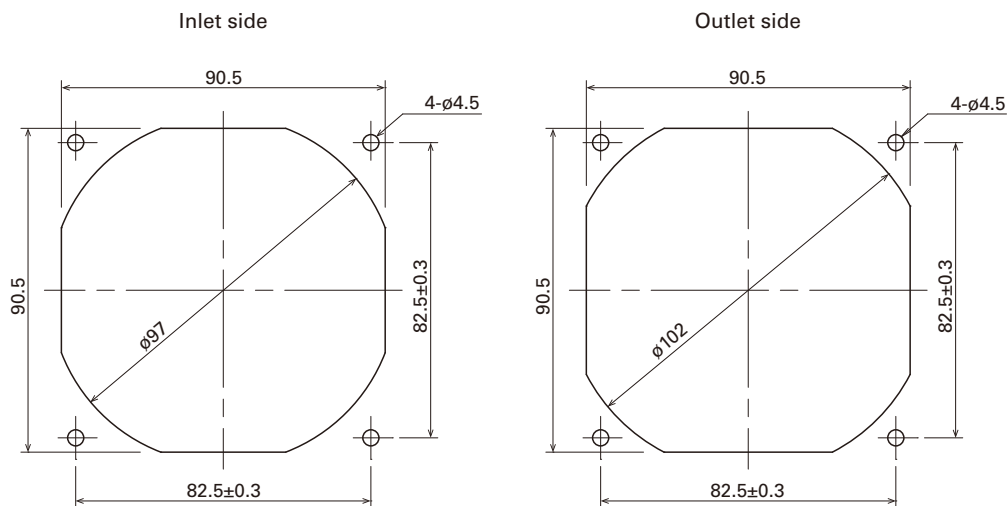

Notice

- Please read the "Safety Precautions" on our website before using the product.
- The products shown in this catalog are subject to Japanese Export Control Law. Diversion contrary to the law of exporting country is prohibited.
- For protecting fan bearings against electrolytic corrosion near strong electromagnetic noise sources, we provide effective countermeasures such as Electrolytic Corrosion Proof Fans and EMC guards. Contact us for details.

SANYO DENKI CO., LTD. 3-33-1 Minami-Otsuka, Toshima-ku, Tokyo 170-8451, Japan TEL: +81 3 5927 1020

<https://www.sanyodenki.com>

The names of companies and/or their products specified in this catalog are the trade names, and/or trademarks and/or registered trademarks of such respective companies.

"San Ace" is a trademark of SANYO DENKI CO.,LTD.

Specifications are subject to change without notice.

CATALOG No. C1100B001 '20.3