



SILICON BRIDGE RECTIFIERS

4.0A GLASS PASSIVATED BRIDGE RECTIFIER

FEATURES :

- * High current capability
- * High surge current capability
- * High reliability
- * Low reverse current
- * Low forward voltage drop
- * Ideal for printed circuit board

MECHANICAL DATA :

- * Case : Molded plastic
- * Epoxy : UL94V-O rate flame retardant
- * Terminals : Plated lead solderable per MIL-STD-202, Method 208 guaranteed
- * Polarity : Polarity symbols marked on case
- * Mounting position : Any
- * Weight : 5.15 grams

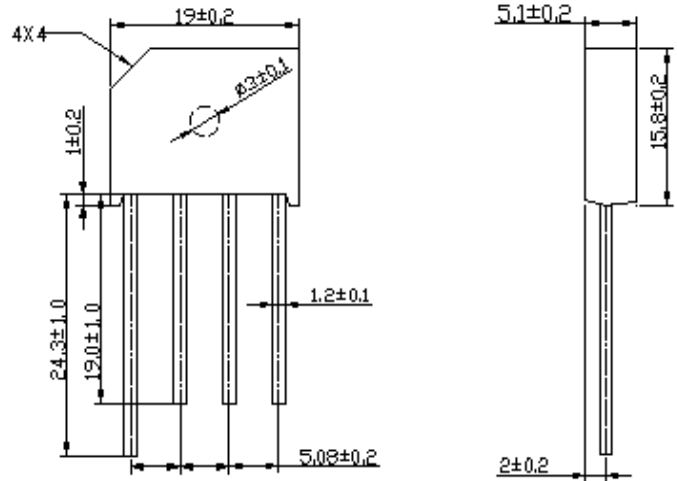

Dimensions in inches and (millimeters)

MAXIMUM RATINGS AND ELECTRICAL CHARACTERISTICS

Rating at 25 °C ambient temperature unless otherwise specified.

Single phase, half wave, 60 Hz, resistive or inductive load.

For capacitive load, derate current by 20%.

RATING	SYMBOL Marking	RS401 KBL400	RS402 KBL401	RS403 KBL402	RS404 KBL404	RS405 KBL406	RS406 KBL408	RS407 KBL410	UNIT
Maximum Recurrent Peak Reverse Voltage	V _{RRM}	50	100	200	400	600	800	1000	Volts
Maximum RMS Voltage	V _{RMS}	35	70	140	280	420	560	700	Volts
Maximum DC Blocking Voltage	V _{DC}	50	100	200	400	600	800	1000	Volts
Maximum Average Forward Current T _c =50°C	I _{F(AV)}	4.0							Amps.
Peak Forward Surge Current Single half sine wave Superimposed on rated load (JEDEC Method)	I _{FSM}	200							Amps.
Rating for fusing (t < 8.3 ms.)	I ² t	166							A ² S
Maximum Forward Voltage per Diode at I _F = 4 Amps.	V _F	1.1							Volts
Maximum DC Reverse Current at Rated DC Blocking Voltage	I _R	10							μA
		1.0							mA
Typical Thermal Resistance (Note 1)	R _{θJA}	10							°C/W
Operating Junction Temperature Range	T _J	- 50 to + 150							°C
Storage Temperature Range	T _{STG}	- 50 to + 150							°C



FIG.1 - DERATING CURVE FOR OUTPUT RECTIFIED CURRENT

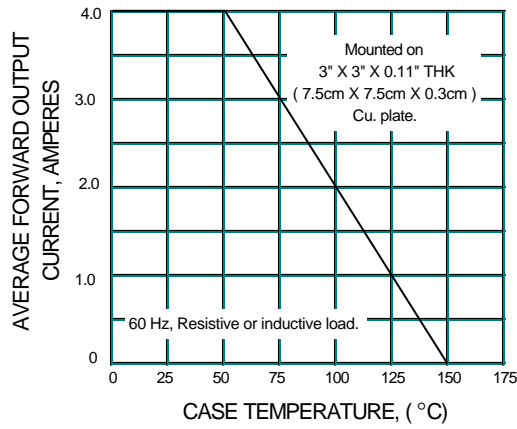

FIG.2 - MAXIMUM NON-REPETITIVE PEAK FORWARD SURGE CURRENT

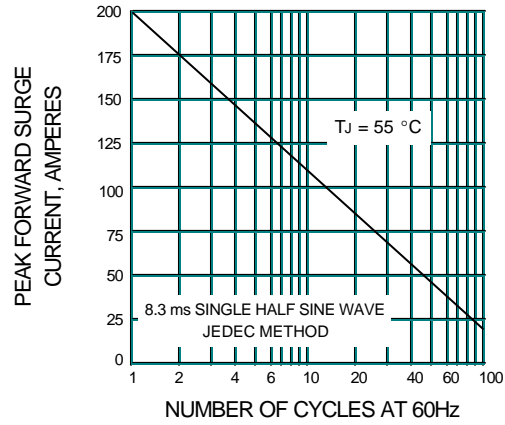

FIG.3 - TYPICAL FORWARD CHARACTERISTICS PER DIODE

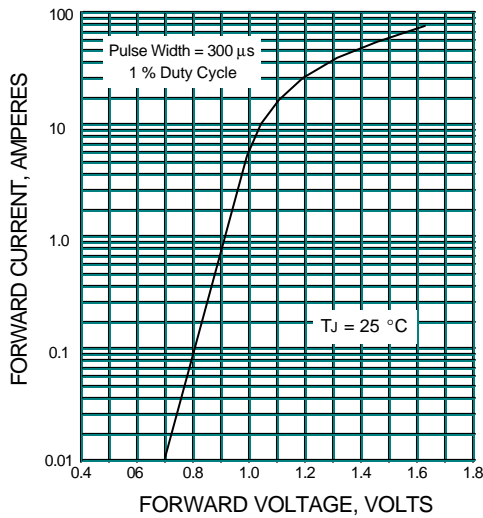

FIG.4 - TYPICAL REVERSE CHARACTERISTICS

