

REVISIONS			
REV.	DESCRIPTION	DATE	APPROVED
A	INITIAL RELEASE	10/14/13	D.N.

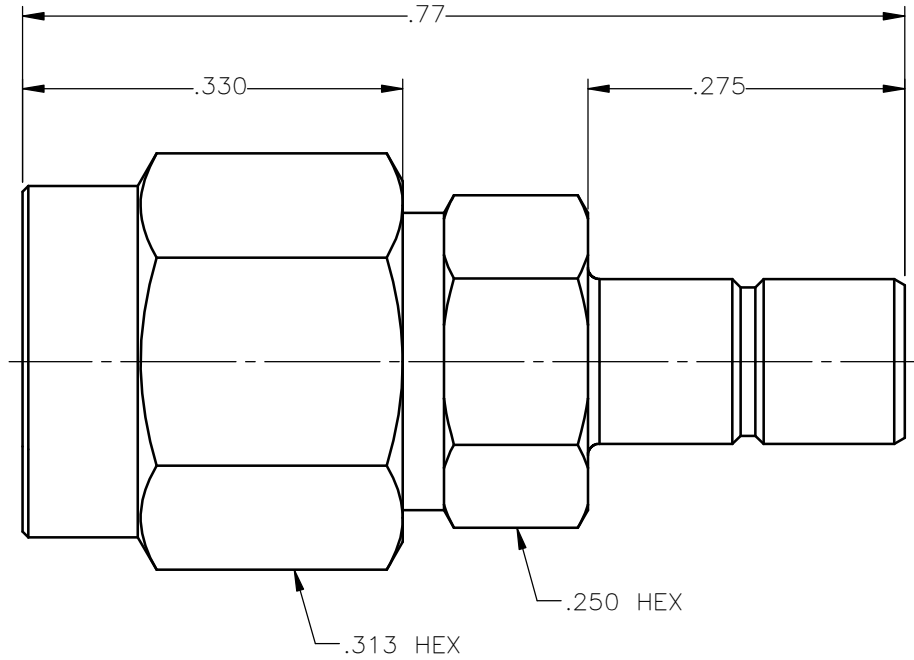



NOTES:

MATERIALS:

1. BODY & COUPLING NUT = STAINLESS STEEL PER ASTM A582, ALLOY 303, CONDITION "A".
2. INSULATOR = VIRGIN WHITE TEFLON PER ASTM D1710, GRADE 1, TYPE I, CLASS "B".
3. CONTACT & RETAINING RING = BERYLLIUM COPPER PER ASTM B196, ALLOY C17300, TEMPER TD04.
4. GASKET = SILICONE RUBBER PER ZZ-R-765, CLASS 2B, GRADE 65-75.

FINISHES:

1. BODY & COUPLING NUT = PASSIVATE PER QQ-P-35, TYPE VI.
2. CONTACT = GOLD PLATE PER MIL-G-45204, TYPE II, CLASS 1, GRADE C, OVER .00010 TO .00020 STRESS FREE SULFAMATE NICKEL PER QQ-N-290.

UNLESS OTHERWISE SPECIFIED DIMENSIONS ARE IN INCHES TOLERANCES ON	DWN:	DATE	 Property of Radiall This document cannot be reproduced or communicated to a third party without prior written permission of RADIALL.			
	D.N.	10/14/13				
DECIMAL	ANGLE	CHKD:	DATE	SMA PLUG TO SMB MALE JACK		
		J.S.	10/14/13			
		APVD:	DATE			
		J.M.	10/14/13			
REFERENCE:	MATERIALS & FINISHES:		SIZE	FSCM NO.	DWG NO.	REV
ORIGINATED: D.N. DATE: 10/14/13	SEE NOTES		A	19505	5928-9503-000	A
			SCALE 6:1	THIRD ANGLE PROJECTION		SHEET 1 OF 1

5928-9503-000

Mouser Electronics

Authorized Distributor

Click to View Pricing, Inventory, Delivery & Lifecycle Information:

Radial:

[5928-9503-000](#)