

BEST CONTACTS FOR YOUR SUCCESS



Telegärtner

KARL GÄRTNER GMBH

NETWORKING COMPONENTS

COAXIAL CONNECTORS

CABLE ASSEMBLIES

PRECISION TURNED PARTS

PLASTIC INJECTION MOULD PARTS

INDUSTRIAL ELECTRONICS

**Better
all-round.**



DataVoice

Circular connectors STX M12x1 IP67

Connector series for industrial applications

STX M12x1 IP67 connector series

With the STX M12x1 IP67 connector series, Telegärtner offers solutions for the demand of the industry for consistent cabling of industrial communication networks in accordance with IEC 61918 which prescribes M12x1 circular connectors in 4- and 8-pole versions as a plug interface.

The series contains M12x1 D- and X-coded connectors which are suitable for connecting to both solid conductors and stranded wire cables as well as offering 360° shield contacting.

Another part of the STX M12x1 IP67 connector series are printed circuit board bulkhead sockets with housings for front or back mounting.

The range is rounded off by pre-assembled connecting cables for the device connection between machines/terminating equipments or machine/terminating equipment to the control cabinet.

Designed for transmitting maximum data rates in industrial applications



As 4-pole, D-coded compact connectors in Cat.5e, the M12 from Telegärtner can transmit data rates up to 100 Mbit/s in the PROFINET environment. X-coded in Cat.6_A, the 8-pole version can transmit data rates up to 10 Gbit/s according to CDV IEC 61076-2-109. The high bandwidth is ensured by separating the four pairs transmission technically by a cross shield (X-coding). Additionally a power supply to connected terminating equipments is possible.

The STX M12x1 connector series can be used for applications such as security and video surveillance (CCTV), passenger information systems (PIS), production systems or production monitoring with high-resolution cameras. Users can connect X-ray machines for baggage inspection at airports, for example, encapsulated and safe from manipulation with the M12 circular connector. But the M12 is also a real trump card in railway vehicles: It helps to distribute the increasing data volume reliably and to transmit the data to all connected systems and devices in the train, for example, to cameras or switches.



Renewable energy



Transport



Industrial applications

STX M12x1 Bulkhead Sockets X-coded IP67

An important part of the STX M12x1 connector series are the bulkhead sockets in Cat.6A. They are available with housings for front or back mounting as well as versions without housings with

a fourfold shield connection to the printed circuit board and feature versatile mounting possibilities.

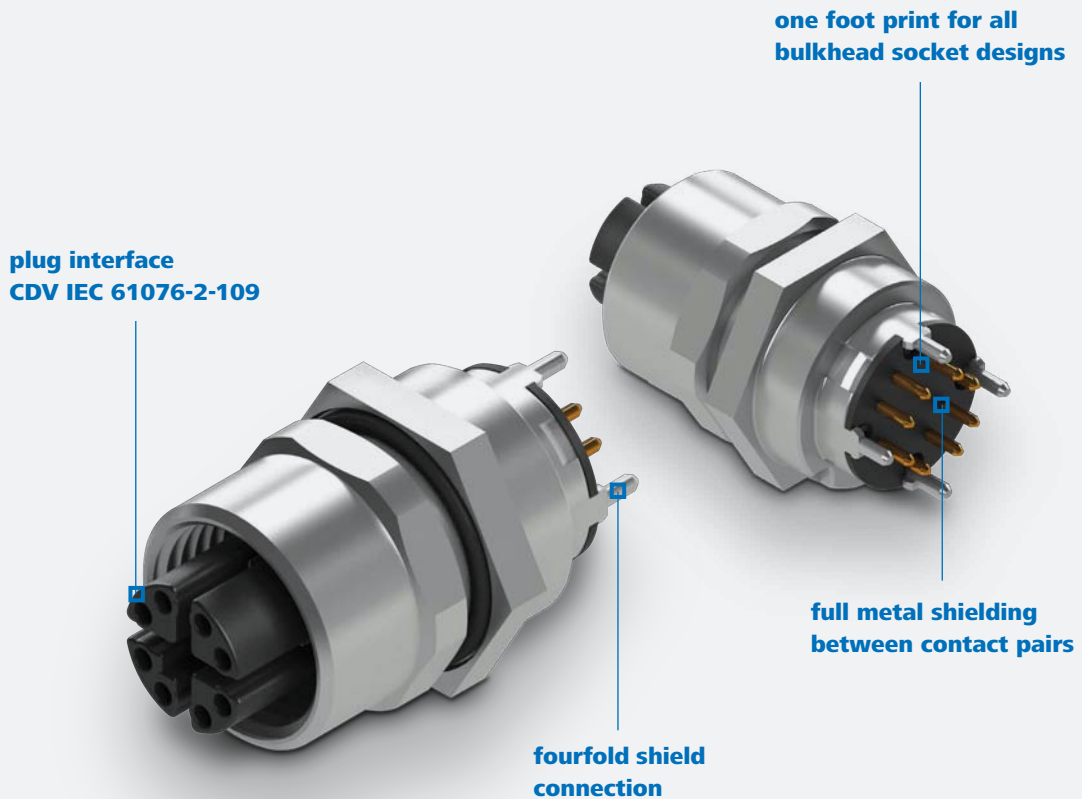

STX M12x1 Bulkhead Socket X-coded

Mechanical Characteristics

Connectors	CDV IEC 61076-2-109
Insertion force	≤ 30 N
Durability (mating cycles)	≥ 100
Material: housing	zinc diecast nickel plated / brass nickel plated
Material: contact body	PA
Material: contacts	CuSn
Material: contact finish	Au
Material: gaskets	FKM; NBR

Environmental Requirements

Shock	50 g
Protection against particulate ingress	IP6X
Protection against water / immersion	IPX7
Ambient temperature	-40° C to +85° C

Electrical Characteristics

Contact resistance	≤ 5 mΩ
Insulation resistance	≥ 100 mΩ
Voltage proof: contact-contact	≥ 500 V, DC
Voltage proof: contact-shield	≥ 500 V, DC
PoE+ acc to IEEE 802.3at	Adequate for Power over Ethernet+

Transmission Characteristics

10 Gigabit Ethernet acc. to IEEE 802.3an	Adequate for 10 Gigabit Ethernet
Category 6A	ISO/IEC 11801; DIN EN 50173-1
Class EA	ISO/IEC 11801; DIN EN 50173-1

STX M12x1 Cable Plug X-coded IP67

The basic structure of the new Telegärtner connector with X-coding corresponds to M12 system in world-wide use that has found its way into applications in many different branches with extreme conditions thanks to its compact design and industrial compatibility. The extremely robust M12x1 connector in Cat.6_A from the STX

programme can be fitted on site without any special tools. This assembly-friendly connector also features very good shield contacting and covers a wide range of wire diameters (0.9 – 1.6 mm) and cable diameters (5.5 – 9 mm).

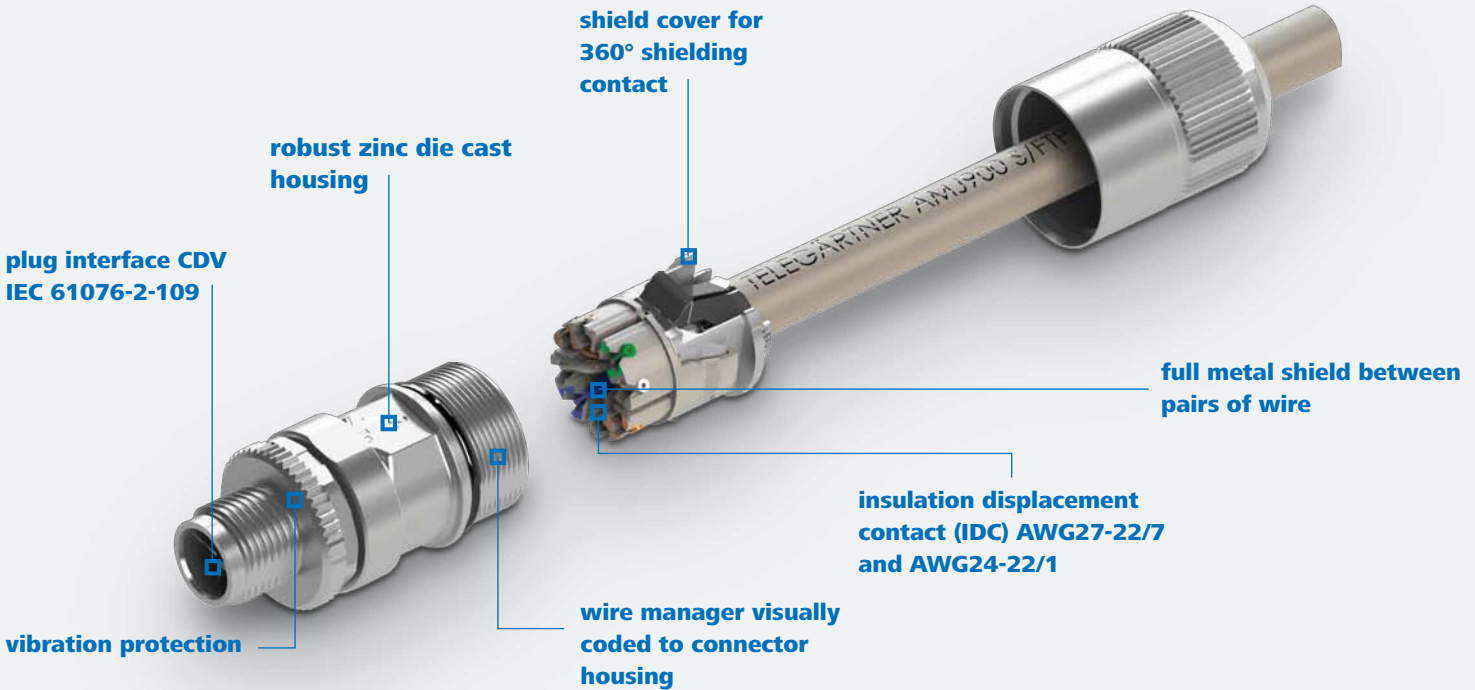

STX M12x1 Cable Plug X-coded

Mechanical Characteristics

Connectors	CDV IEC 61076-2-109
Insertion force	≤ 30 N
Durability (mating cycles)	≥ 100
Material: housing	zinc diecast nickel plated / brass nickel-plated
Material: wire pair presorting	PA UL94 V0
Material: shield	German silver
Material: pressure screw	brass nickel-plated
Material: contacts	brass
Material: contact finish	Au over Ni
Wire diameter	0.9 - 1.6 mm
Cu-Conductor diameter: stranded	0.46 - 0.76 mm (AWG27 - 22/7)
Cu-Conductor diameter: solid	0.51 - 0.64 mm (AWG24 - 22/1)
Cable diameter	5.5 - 9.0 mm

Environmental Requirements

Shock	50 g
Protection against particulate ingress	IP6X
Protection against water / immersion	IPX7
Ambient temperature	-40° C to +85° C

Electrical Characteristics

Contact resistance	≤ 10 mΩ
Insulation resistance	≥ 100 mΩ
Voltage proof: contact-contact	≥ 500 V, DC
Voltage proof: contact-shield	≥ 500 V, DC
PoE+ acc to IEEE 802.3at	Adequate for Power over Ethernet+

Transmission Characteristics

10 Gigabit Ethernet acc. to IEEE 802.3an	Adequate for 10 Gigabit Ethernet
Category 6 _A	ISO/IEC 11801; DIN EN 50173-1
Class E _A	ISO/IEC 11801; DIN EN 50173-1

STX M12x1 Connecting Cable X-coded

For the connection between machines or other terminating equipments as well as connection of the machine or terminating equipment to the control cabinet, Telegärtner also offers pre-

assembled connecting cables in Cat.6A. The connecting cables M12x1 with x-coding have an S/FTP 4x2xAWG26/7 PUR structure and are suitable for an increased temperature range of -40° C to + 85° C.



STX M12 Connecting Cable X-coded

	Connecting Cable S/FTP Cat.7 PUR
Mechanical Characteristics	
Durability (mating cycles) M12	≥ 100
Durability (mating cycles) RJ45	≥ 750
Cable structure	LI02YSC11Y PUR 4x2xAWG 26/7 PiMF
Stranded wire	AWG26 (7 x 0.16 mm)
Wire insulation	Foam PE, Ø 1.04 mm
Pair shielding	Al-foil, outside conducting
Overall shielding	tin plated copper braid
Outer jacket	Ø 6.2 ±0.2 mm
Colour	RAL 6018
Thermal and Climatic Characteristics	
UL	E344985
flame-retardant test	IEC 60332-1
Operating temperature in °C	-40° C to 85° C

The technical data for the connectors can be extracted from the table on the left.

Assembly of the STX M12x1 connector X-coded

Thanks to an intelligent wire management and a simple screw connection system, the individual components of the STX M12x1 cable plug can be assembled quickly and easily on site completely without the use of special tools.

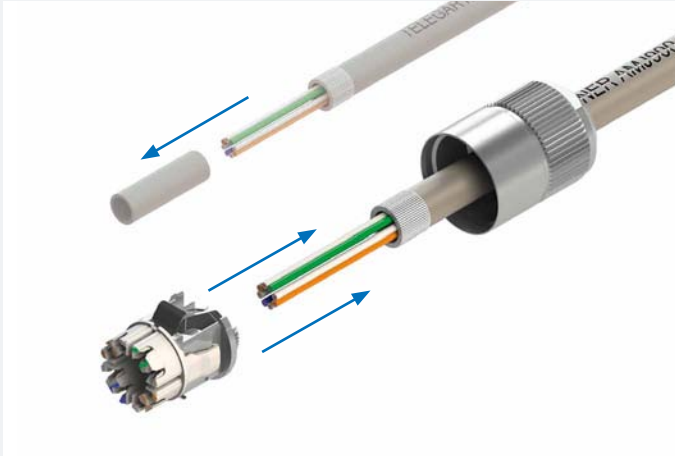

Step 1: Prepare cables

- Slide over cable gland and seal at least 40 mm
- Remove outer jacket, fold braid shield backwards
- Pre-sort pairs of wire

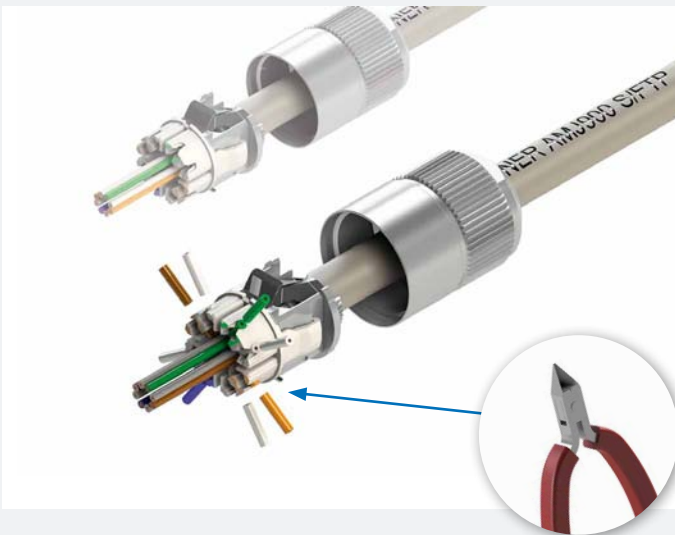

Step 2: Insert cables

- Insert pairs of wire into the wire manager, actuate the shield spring
- Untwist pairs of wire, insert the individual wires into the wire manager and cut off protruding wire flush



Step 3: Screw on connector

- Insert wire manager into plug body (pay attention to position)
- Tighten the cable gland with an open-ended wrench
- Use an additional seal for cable diameters between 5.5 and 7.5 mm

Versatile mounting possibilities

Front or back mounting: Telegärtner always offers component manufacturers the right solution for integration into their products.

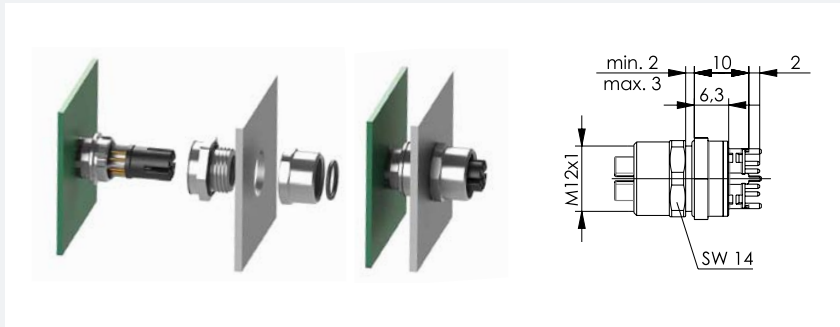

Back mounting:

- M12 bulkhead socket
- X-coded
- 2 piece design
- distance from PCB to housing 10 mm

Order no.: J80120A0120

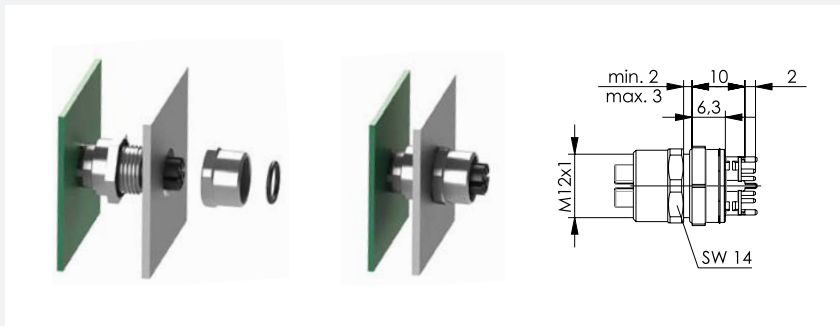

Back mounting:

- M12 bulkhead socket
- X-coded
- 1 piece design
- distance from PCB to housing 10 mm

Order no.: J80020A0120

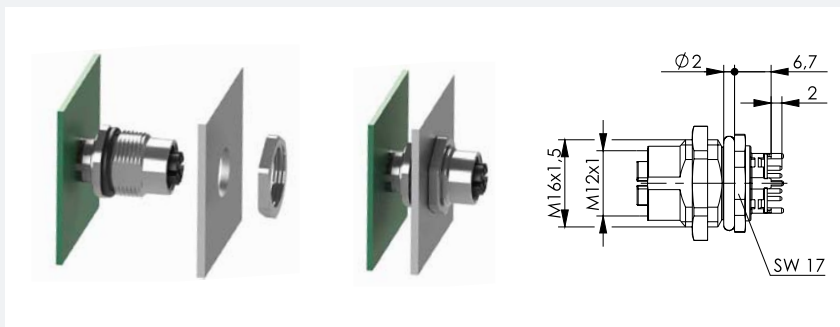

Back mounting:

- M12 bulkhead socket
- X-coded
- 1 piece design
- distance from PCB to housing 6.7 mm

Order no.: J80020A0121

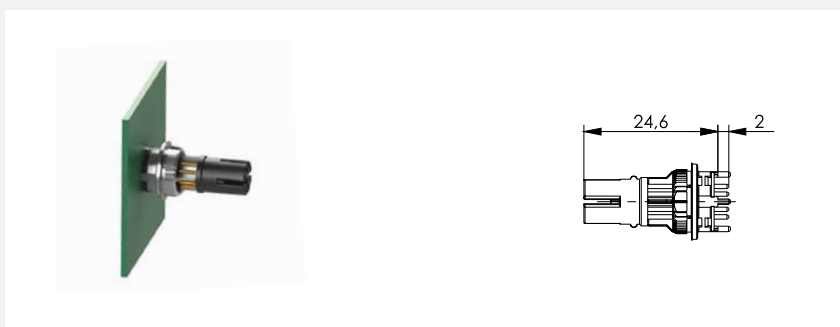

Back mounting:

- M12 bulkhead socket
- X-coded
- without housing
- distance from PCB customer-specific

Order no.: J80220A0120

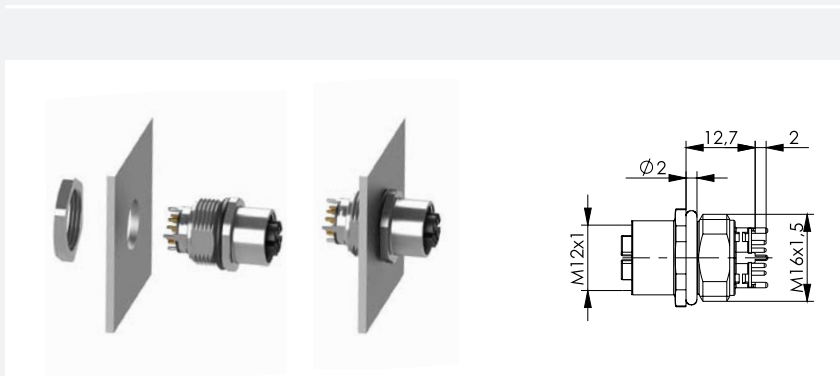

Front mounting:

- M12 bulkhead socket
- X-coded
- 1 piece design
- distance from from PCB to housing 12.7 mm

Order no.: J80020A0122

Order Information:

Product	Order no.	Description	Coding
M12x1 Cable Plug	J80026A0200	STX M12x1 CP D-cod. Cat.5 4 pole, D-coded, straight, plug set, 360° shielding, screw termination, length of connector: 70 mm, field assembly	D-coded
M12x1 Bulkhead Socket	J80120A0220	STX M12x1 BS D-cod. Cat.5 4 pole, D-coded, straight, 2 pc. single design, screen connection single, solder connection THR, gap to PCB 10 mm, back mounting	
	J80020A0221	STX M12x1 BS D-cod. Cat.5 4 pole, D-coded, straight, 1 pc. design, screen connection quad, solder connection THR, gap to PCB 5.7 mm, back mounting	
	J80020A0222	STX M12x1 BS D-cod. Cat.5 4 pole, D-coded, straight, 1 pc. design, screen connection 360°, solder connection THR, gap to PCB 11 mm, front mounting	
	J80220A0220	STX M12x1 BS D-cod. Cat.5 4 pole, D-coded, straight, without housing, screen connection single, solder connection THR, back mounting	
M12x1 Cable Plug	J80026A0100	STX M12x1 CP X-cod. Cat.6 _A 8 pole, X-coded, straight, plug set, 360° shielding, IDC, plug length: 59 mm, field assembly	X-coded
M12x1 Bulkhead Socket	J80020A0120	STX M12x1 BS X-cod. Cat.6 _A 8 pole, X-coded, straight, 1 pc. (J80020A0120) resp. 2 pc. (J80120A0120) design, screen connection quad, solder connection THR, gap to PCB 10 mm, back mounting	
	J80120A0120		
	J80020A0121	STX M12x1 BS X-cod. Cat.6 _A 8 pole, X-coded, straight, 1 pc. design, screen connection quad, solder connection THR, gap to PCB 6,7 mm, back mounting	
	J80020A0122	STX M12x1 BS X-cod. Cat.6 _A 8 pole, X-coded, straight, 1 pc. design, screen connection quad, solder connection THR, gap to PCB 12,7 mm, front mounting	
J80220A0120	STX M12x1 BS X-cod. Cat.6 _A 8 pole, X-coded, straight, without housing, screen connection quad, solder connection THR, gap to PCB customized, back mounting		
M12x1 Coupler	J80029A0100	STX M12x1-M12x1 CO X-cod. Cat.6 _A mating face 1: 8 pole, X-coded, straight; mating face 2: 2 pole, X-coded, straight; Cat.6 _A	X-coded
	J80629A0100	STX M12x1-M12x1 CO X-cod. Cat.6 _A mating face 1: 8 pole, X-coded, straight; mating face 2: 2 pole, X-coded, angled; Cat.6 _A	
	J80029A0200	STX M12x1-RJ45 CO X-cod. Cat.6 _A mating face 1: 8 pole, X-coded, straight; mating face 2: RJ45, straight; Cat.6 _A	
	J80629A0200	STX M12x1-RJ45 CO X-cod. Cat.6 _A mating face 1: 8 pole, X-coded, straight; mating face 2: RJ45, angled; Cat.6 _A	
M12x1 Accessories	H80030A0008	STX M12x1 plug protective cap with wrist strap	for D- and X-coded
	H80030A0009	STX M12x1 socket protective cap	
	H80030A0010	STX M12x1 socket protective cap with wrist strap	

Connecting Cables:



M12x1 D-coded	2x M12x1 Cable Plug black overmoulded IP67 Cable: SF/UTP, 2x2xAWG22/7, Cat.5, PUR, Outer Jacket green	M12x1 Cable Plug black overmoulded IP67 to RJ45 Plug Crimp IP20 Cable: SF/UTP, 2x2xAWG22/7, Cat.5, PUR, Outer Jacket green	M12x1 Cable Plug black overmoulded IP67 to free cable end Cable: SF/UTP, 2x2xAWG22/7, Cat.5, PUR, Outer Jacket green
Length 0.5 m	L80210A0000	L80310A0000	L83610A0000
Length 1.0 m	L80210A0001	L80310A0001	L83610A0001
Length 2.0 m	L80211A0000	L80311A0000	L83611A0000
Length 3.0 m	L80212A0000	L80312A0000	L83612A0000
Length 5.0 m	L80213A0000	L80313A0000	L83613A0000
Length 7.5 m	L80214A0000		L83614A0000
Length 10.0 m	L80215A0000		L83615A0000



M12x1 X-coded	2x M12x1 Cable Plug black overmoulded IP67 Cable: S/FTP, 4x2xAWG26/7, Cat.7, PUR, Colour Outer jacket green	M12x1 Cable Plug black overmoulded IP67 to RJ45 Plug Crimp IP20 Cable: S/FTP, 4x2xAWG26/7, Cat.7, PUR, Colour Outer jacket green	M12x1 Cable Plug black overmoulded IP67 to free cable end Cable: S/FTP, 4x2xAWG26/7, Cat.7, PUR, Colour Outer Jacket green
Length 0.5 m	L80000A0000	L80100A0000	L83500A0000
Length 1.0 m	L80000A0001	L80100A0001	L83500A0001
Length 2.0 m	L80001A0000	L80101A0000	L83501A0000
Length 3.0 m	L80002A0000	L80102A0000	L83502A0000
Length 5.0 m	L80003A0000	L80103A0000	L83503A0000
Length 7.5 m	L80004A0000	L80104A0000	L83504A0000
Length 10.0 m	L80005A0000	L80105A0000	L83505A0000



M12x1 X-coded	M12x1 Cable Plug black overmoulded IP67 to M12x1 Cable Socket black overmoulded IP67 Cable: S/FTP, 4x2xAWG26/7, Cat.7, PUR, Colour Outer Jacket green	M12x1 Cable Socket IP20 to RJ45 Plug Crimp IP20 Cable: S/FTP, 4x2xAWG26/7, Cat.7, PUR, Colour Outer Jacket green	M12x1 Cable Socket black overmoulded IP67 to free cable end Cable: S/FTP, 4x2xAWG26/7, Cat.7, PUR, Colour Outer Jacket green
Length 0.5 m	L82000A0000	L82100A0000	L84500A0000
Length 1.0 m	L82000A0001	L82100A0001	L84500A0001
Length 2.0 m	L82001A0000	L82101A0000	L84501A0000
Length 3.0 m	L82002A0000	L82102A0000	L84502A0000
Length 5.0 m	L82003A0000	L82103A0000	L84503A0000
Length 7.5 m	L82004A0000		L84504A0000
Length 10.0 m	L82005A0000		L84505A0000

Other industrial cabling components from the STX programme



In factory, machine or plant cabling: With the industrial connectors of Variant 1, Variant 4, Variant 5 and Variant 14 from the STX platform and industrial connectors of Variant 6, Telegärtner offers you top class, standard-compliant Industrial Ethernet solutions.

More information about our STX programme is available
from your dealer or under
www.telegaertner.com/stx

Telegärtner
Karl Gärtner GmbH

Lerchenstr. 35
D-71144 Steinenbronn

Tel.: +49 (0) 71 57/1 25-100
Fax: +49 (0) 71 57/1 25-120

Email: info@telegaertner.com
Web: www.telegaertner.com

Your distributor: