

PRODUCT NUMBER
76745-YXX-XXLF

ROHS COMPATIBLE, SEE NOTE 8
TOTAL NB OF POS (04 TO 72 POS)
OPTION LETTER, SEE NOTE 6
PIN STYLE

- 1 = 0.76µm GOLD/GXT,
- 3 = 2µm MIN MATTE TIN FULL PLATED
- 5 / 8 = 0.38µm GOLD/GXT

1.27µm Ni MIN UNDERPLATING

G = 0.76µm GOLD/GXT IN ZONE "A", 2µm MATTE TIN IN ZONE "B"
ALL OVER 1.27µm Ni MIN

NOTES:

1. HOUSING MAT'L : HIGH TEMPERATURE THERMOPLASTIC: UL94V-0 COLOR: BLACK.
2. PIN MATERIAL : PHOSPHOR BRONZE.
3. 12N MIN RETENTION IN EITHER DIRECTION.
4. TO DETERMINE DIMENSIONS :
N = NUMBER OF POSITIONS PER ROW
EXAMPLE : 8 POS PER ROW, N x 2.54 = 20.32mm
5. FOR STANDARD SELECTIVE GOLD PLATED PRODUCTS SEE DRAWINGS 54112 & 54122.
6. OPTION LETTER :
- = STANDARD PACKAGING IN POLYBAG
V = POLYBAGS PACKAGING FOR CUSTOMER DEDICATED PART
B = TUBE WITH PICK UP CAP AS AVAILABLE
7. RETENTION IS APPLIED TO TWO ADJACENT PINS AT EACH END OF THE PRODUCT SEE SCHEMA 1 OMIT FROM PRODUCT NUMBER IF THIS FEATURE IS NOT APPLICABLE
8. ROHS COMPATIBLE PRODUCT SPECIFICATIONS

a - PLATING:

- "LF" MEANS THE PRODUCT IS LEAD-FREE,
2µm MINIMUM MATTE TIN OVER 1.27µm
MINIMUM NICKEL UNDERPLATE.

b - MANUFACTURING PROCESS COMPATIBILITY

- THE HOUSING WILL WITHSTAND EXPOSURE TO
260°C ±5°C SOLDER BATH TEMPERATURE FOR
WITH A 1.6mm MIN THICK CIRCUIT BOARD.

c - LABELING:

- MEETS PACKAGING SPECS AS PER GS-14-920
- LEGAL STATEMENT: SEE GS-47-0004

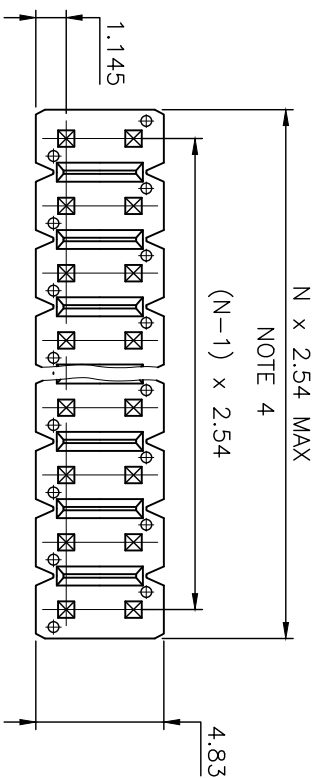

SCHEMA 1
TWO RETENTION PIN AT EACH
END OF THE PRODUCT

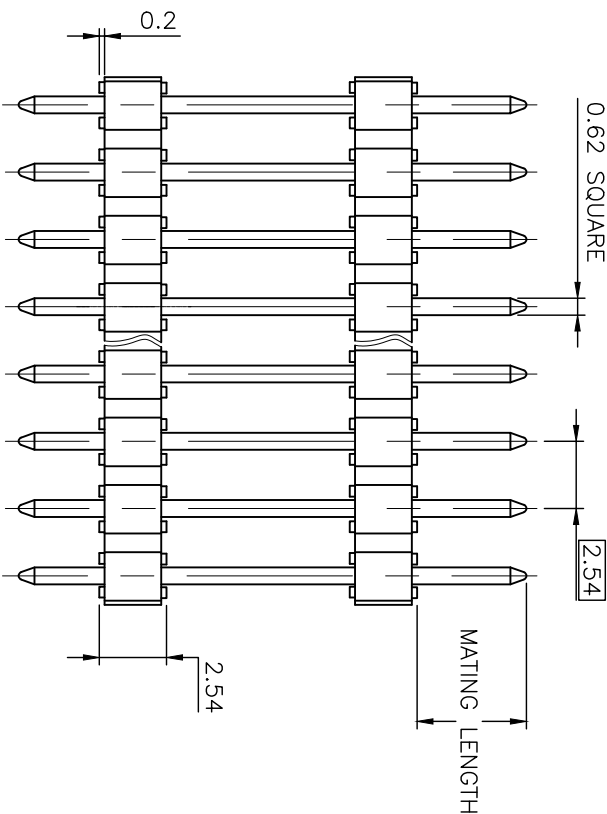
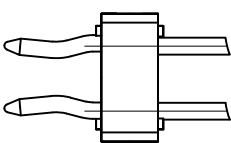

OAL (OVERALL LENGTH)
REF

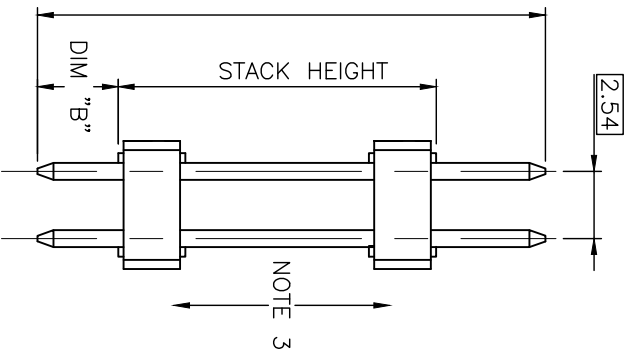

2.54±0.08
NON-ACCUM TYP

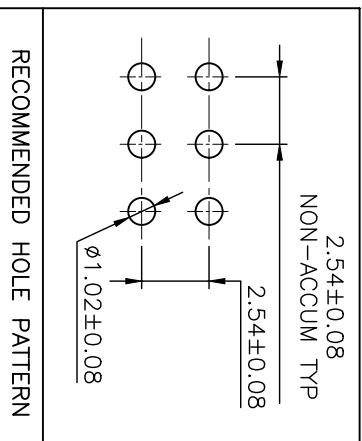

mat'l. code		surface	tolerance	projection	product family
SEE NOTES		ISO 1302	ISO 406 ISO 1001		BSTIK
ltr	ecn no	dr	date	tolerances unless otherwise specified	
FF	B-19782	AMA	14.12.18	xx ±0.3	
FG	B-20322	AMA	15.01.27	angles linear xxx ±0.13	
FH	F-22479	BVE	15.11.12	xxx ±0.05	
FK	F-28617	DDE	17.11.27	NIZZI P 94.05.05	
FL	F-37603	DDE	20.07.08	engf COMPAGNON J 95.12.05	
Sheet index	revision	FL	CD	F	A
1	2	3	4		
title		scale 5:1		drawing	
HEADER STR,DR		mm		76745	
DOUBLE BODY		mm		CUSTOMER	
sheet 1 of 4		size		A3	
drawing		type		CUSTOMER	

