

SECTION A-A

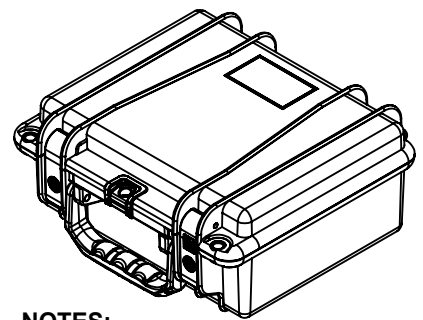

- NOTES:**
- 1) Max. usable inside dimensions are: 9.25" X 7.10" X 4.10"
 - 2) With Metal Lock Latches p/n SE300ML and Plastic Lock Latches p/n SE300PL are optional.
 - 3) Weight empty/Foam: 2.45/2.65 lb.
Buoyancy: 10 lb.
Weight Capacity: 30 lb.

7351 Top Panel for 300

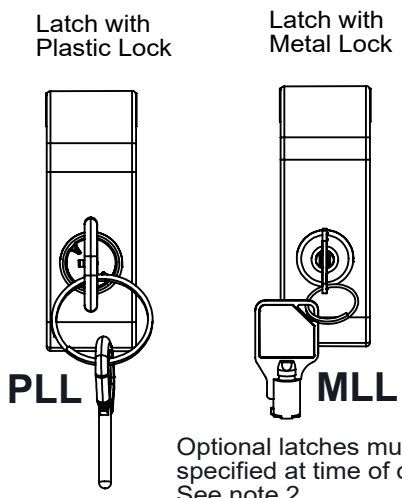
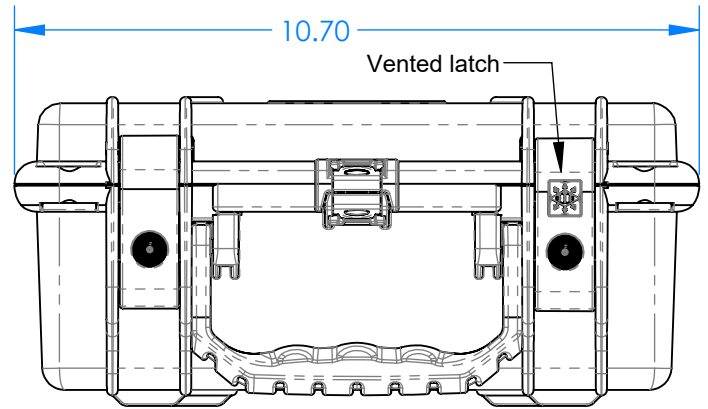
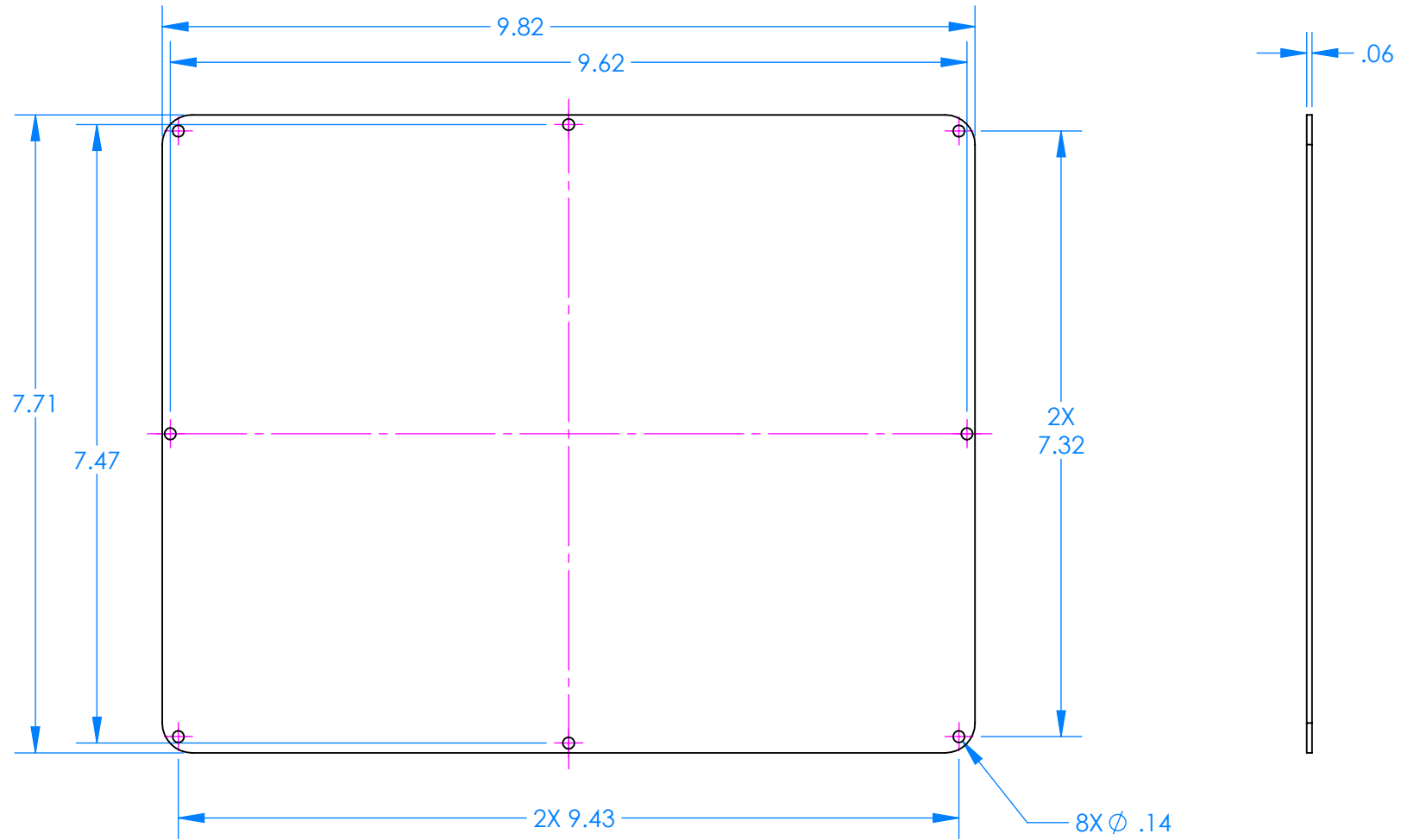

7352 Bottom Panel for 300

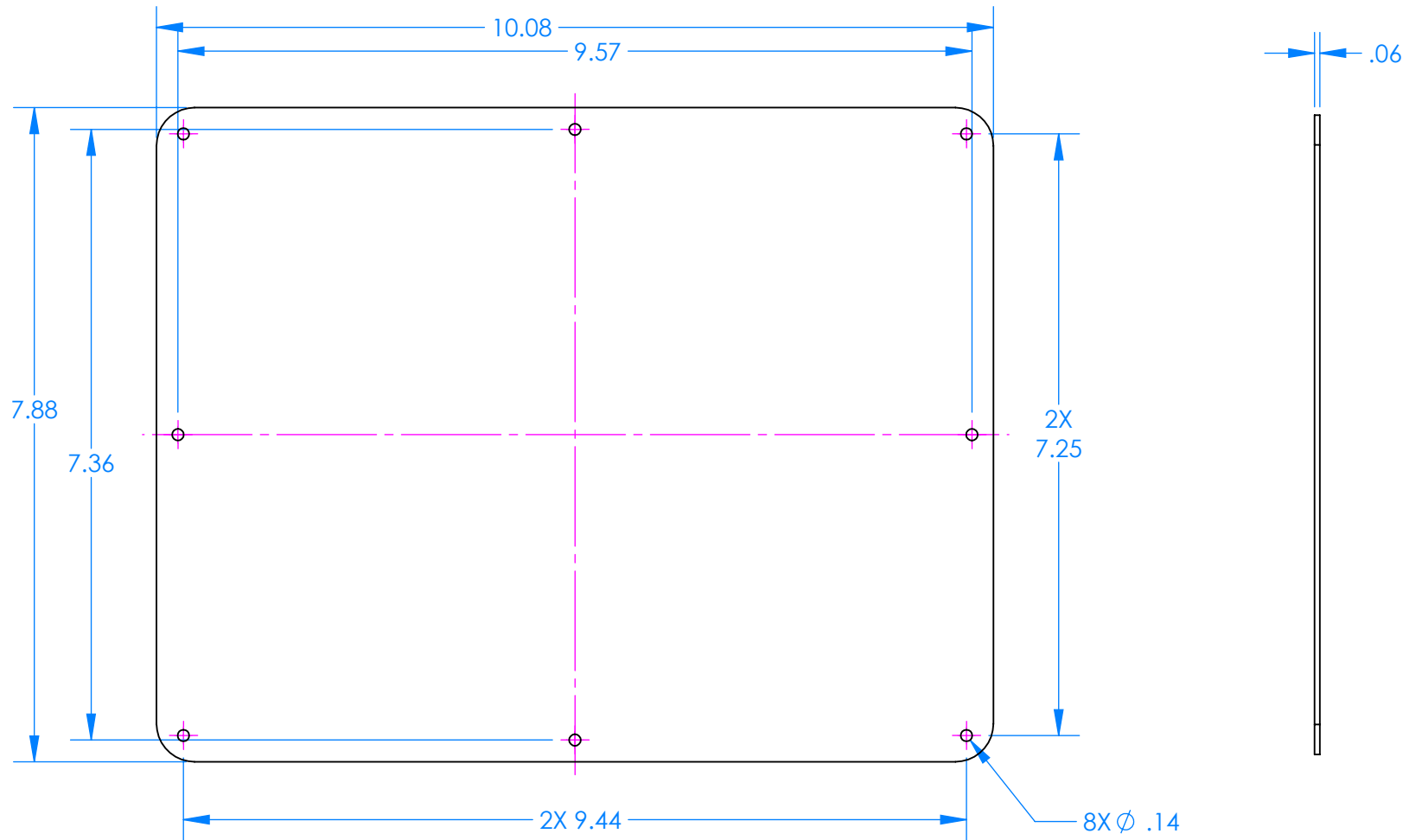

Mouser Electronics

Authorized Distributor

Click to View Pricing, Inventory, Delivery & Lifecycle Information:

[SERPAC:](#)

[SE-300,BK](#)