



Filterless 25W Class F Mono Audio Amplifier

General Description

The LPA2110A is a 25W, class F mono audio amplifier integrated Class AB/D optional mode. It is capable of delivering 25watts of continuous average power to a 4Ω BTL load with less than 10% distortion (THD) from a 14.5V DC power supply. It offers low THD+N, allowing it to achieve high-quality Power Supply sound reproduction. The LPA2110A device is fully protected against faults with short-circuit protection and thermal protection as well as over-voltage and DC protection. Faults are reported back to the processor to prevent devices form being damaged during overload conditions.

Order Information

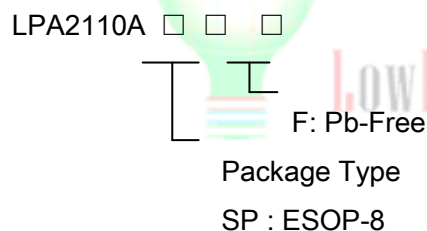

Applications

- ✧ Mini-Micro Component, Speaker Bar, Docks
- ✧ After-Market Automotive
- ✧ Consumer Audio Applications, CRT TV
- ✧ Portable Bluetooth Speaker
- ✧ Square Speaker

Features

- ◆ Wide voltage range: 4V~15.5V
- ◆ 550KHz fixed frequency switching for amplifier
- ◆ 25W Output at 10% THD with a 4Ω Load and 14.5V VDD for amplifier
- ◆ 15W Output at 1% THD with a 4Ω Load and 12V VDD for amplifier
- ◆ Integrated Self-Protection Circuits Including Over-Voltage, Under-Voltage, Over-Temperature, DC-Detect, and Short Circuit
- ◆ High Efficient Class-D Operation: >86%
- ◆ Filterless, Low Quiescent Current and Low EMI
- ◆ Pb-Free Package

Marking Information

Device	Marking	Package	Shipping
LPA2110ASPF	LPS LPA2110A YWX	ESOP-8	4K/REEL

Y: Y is year code. W: W is week code. X: X is series number.

Typical Application Circuit

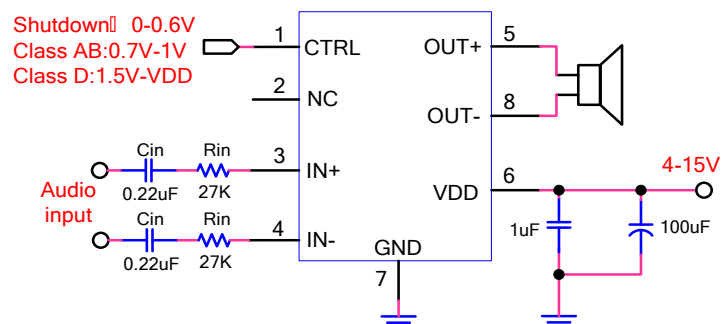



Pin Configuration(TOP View)

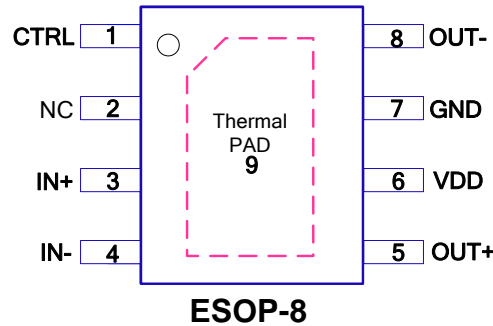

Functional Pin Description

Pin Num.	Pin Name	Description
1	CTRL	Shutdown and Class AB, Class D control. Shutdown:0-0.6V; Class AB:0.7-1V; Class D:1.5V-VDD.
2	NC	No connection.
3	IN+	Positive input of amplifier.
4	IN-	Negative input of amplifier.
5	OUT+	Positive output of signal.
6	VDD	Voltage supply pin.
7	GND	Ground.
8	OUT-	Negative output of signal.
9	Thermal PAD	Power Ground.

Absolute Maximum Ratings ^{Note 1}

- ◇ Supply Voltage to GND ----- -0.3V to 18V
- ◇ Other Pin to GND ----- -0.3V to 9V
- ◇ Maximum Junction Temperature ----- 155°C
- ◇ Operating Ambient Temperature Range (Ta) ----- -40°C to 85°C
- ◇ Maximum Soldering Temperature (at leads, 10 sec) ----- 260°C

Note 1. Stresses beyond those listed under “Absolute Maximum Ratings” may cause permanent damage to the device. These are stress ratings only, and functional operation of the device at these or any other conditions beyond those indicated in the operational sections of the specifications is not implied. Exposure to absolute maximum rating conditions for extended periods may affect device reliability.

Thermal Information

- ◇ Maximum Power Dissipation (ESOP-8, PD,TA=25°C) ----- 1.9W
- ◇ Thermal Resistance (ESOP-8, JA) ----- 65°C/W

ESD Susceptibility

- ◇ HBM(Human Body Mode) ----- 2KV
- ◇ MM(Machine Mode) ----- 200V

**Electrical Characteristics**(T_A = 25°C, VDD = 12V, R_L = 4 Ω, unless otherwise noted)

Parameter	Symbol	Test Conditions	Min	Typ	Max	Units
Supply power	VDD		4		15.5	V
Output power	P _O	THD+N=10%, f=1KHz, R _L =4Ω	VDD=15V	29		W
			VDD=12V	19		
		THD+N=10%, f=1KHz, R _L =8Ω	VDD=15V	16		
			VDD=12V	10		
		THD+N=1%, f=1KHz, R _L =4Ω	VDD=15V	24		
			VDD=12V	15		
		THD+N=1%, f=1KHz, R _L =8Ω	VDD=15V	13		
			VDD=12V	8.5		
Power supply ripple rejection	PSRR	INPUT ac-grounded with C _{IN} =0.47uF, VDD=12V	f=100HZ	-70		dB
			f=1KHz	-73		
Signal-to-noise ratio	SNR	VDD=12V, P _{OUT} =12W, R _L =4Ω	f=1KHz	95		dB
Output integrated noise	V _n	22 Hz to 20kHz, A-weighted filter, THD=1%, R _L =4 Ω		130		μV
Efficency	η	R _L =4Ω, P _O =10W	f=1KHz	86		%
Quiescent current	I _Q	VDD=12V	No load	25		mA
Shutdown current	I _{SD}	VDD=12V, V _{SD} =0		12		uA
Shutdown voltage	V _{CTRL_SD}	VDD=12V	0		0.6	V
Class AB voltage	V _{CTRL_AB}	VDD=12V	0.7		1	
Class D voltage	V _{CTRL_D}	VDD=12V	1.5			
Offset output voltage	V _{OS}	VDD=12V, V _{SD} =0V		6		mV
f _{osc} Oscillator frequency	f _{sw}			550		KHz
start-up time	T _{on}	SD from low to high		180		ms
Thermal shutdown	OTP	Threshold		155		°C
Thermal shutdown Hysteresis	OTPH	Hysteresis		135		



Test setup for graphs

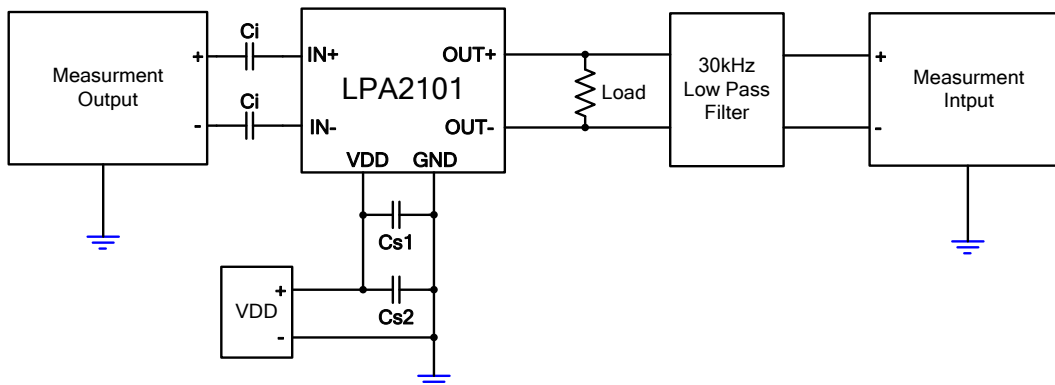

1. Ci was shorted for any common-mode input voltage measurement. All other measurements were taken with Ci = 1μF (unless otherwise noted).
2. Cs1 = 0.1 μF is placed very close to the device. The optional Cs2 = 10 μF is used for datasheet graphs.
3. The 30 kHz low-pass filter is required even if the analyzer has an internal low-pass filter. An RC low-pass filter (1 kΩ, 4700pF) is used on each output for the data sheet graphs.

Typical Operating Characteristic For Amplifier

PO VS THD

Audio Precision

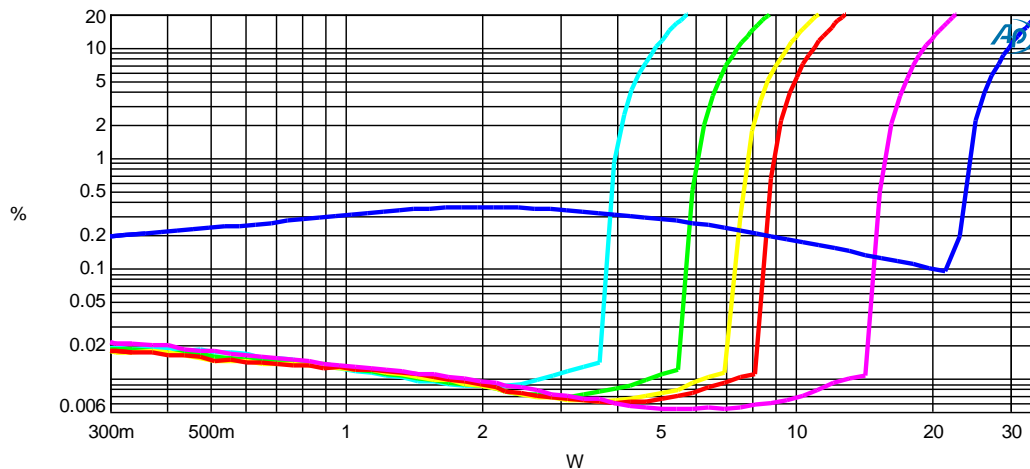

Sweep	Trace	Color	Line Style	Thick	Data	Axis	Comment
1	1	Cyan	Solid	3	Analyzer.THD+N Ratio A	Left	VDD=6V,RL=4ohm
2	1	Green	Solid	3	Analyzer.THD+N Ratio A	Left	VDD=7.4V,RL=4ohm
3	1	Yellow	Solid	3	Analyzer.THD+N Ratio A	Left	VDD=8.4V,RL=4ohm
4	1	Red	Solid	3	Analyzer.THD+N Ratio A	Left	VDD=9V,RL=4ohm
5	1	Magenta	Solid	3	Analyzer.THD+N Ratio A	Left	VDD=12V,RL=4ohm
6	1	Blue	Solid	3	Analyzer.THD+N Ratio A	Left	VDD=15V,RL=4ohm

PO VS THD@4ohm.ats2



Audio Precision

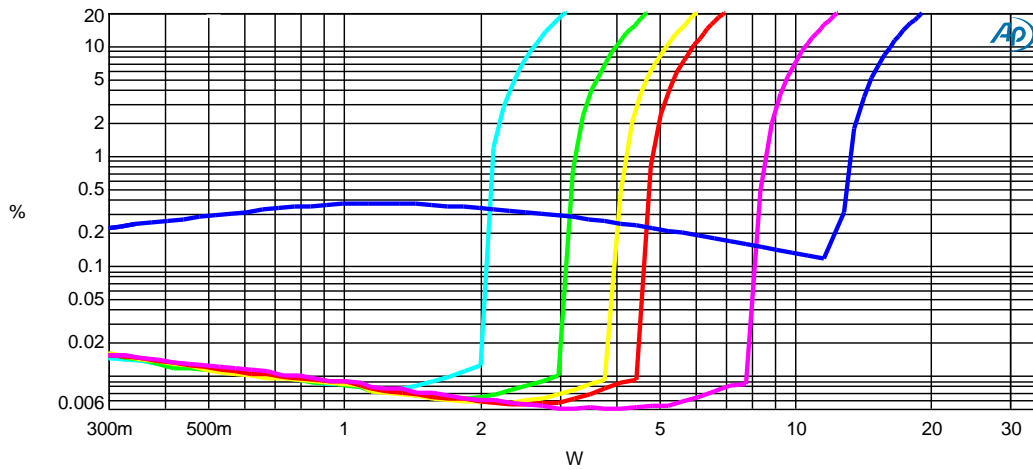

Sweep	Trace	Color	Line Style	Thick	Data	Axis	Comment
1	1	Cyan	Solid	3	Analyzer.TH D+N Ratio A	Left	VDD=6V,RL=8ohm
2	1	Green	Solid	3	Analyzer.TH D+N Ratio A	Left	VDD=7.4V,RL=8ohm
3	1	Yellow	Solid	3	Analyzer.TH D+N Ratio A	Left	VDD=8.4V,RL=8ohm
4	1	Red	Solid	3	Analyzer.TH D+N Ratio A	Left	VDD=9V,RL=8ohm
5	1	Magenta	Solid	3	Analyzer.TH D+N Ratio A	Left	VDD=12V,RL=8ohm
6	1	Blue	Solid	3	Analyzer.TH D+N Ratio A	Left	VDD=15V,RL=8ohm

PO VS THD@8ohm.ats2

Frequency response Audio Precision

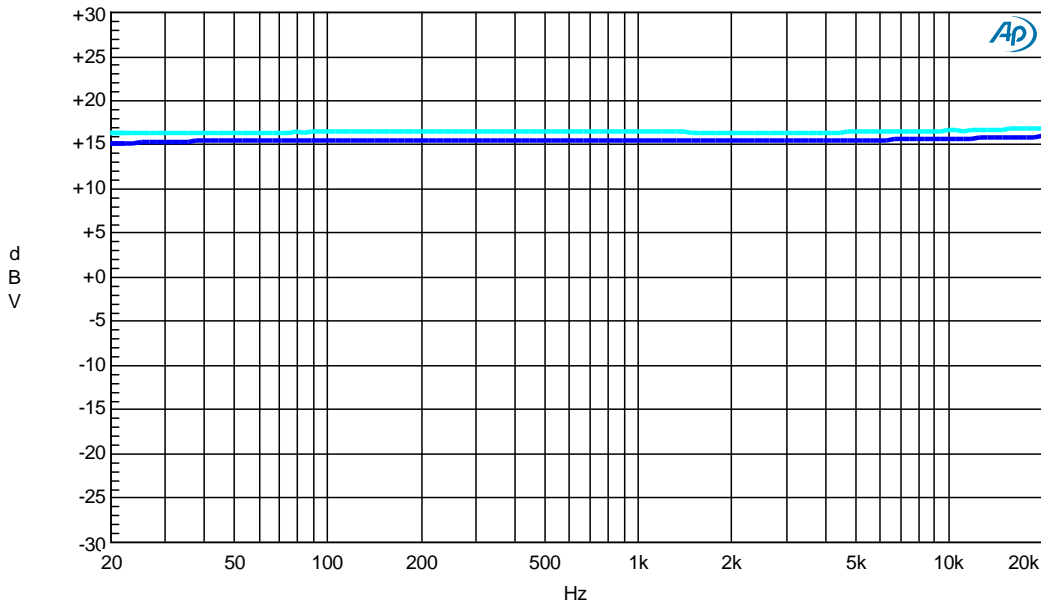

Sweep	Trace	Color	Line Style	Thick	Data	Axis	Comment
5	1	Blue	Solid	3	Analyzer.Level A	Left	VDD=9V,RL=4ohm,Class D,THD=1%
6	1	Cyan	Solid	3	Analyzer.Level A	Left	VDD=9V,RL=4ohm,Class D,THD=10%



Applications Information

Maximum Gain

The LPA2110A has two internal amplifier stages. The first stage's gain is externally configurable, while the second stage's is internally fixed. The closed-loop gain of the first stage is set by selecting the ratio of R_f to R_i while the second stage's gain is fixed at 2x. The output of amplifier 1 serves as the input to amplifier 2, thus the two amplifiers produce signals identical in magnitude, but different in phase by 180°. Consequently, the differential gain for the IC is

$$A_v = 20 \cdot \log [2 \cdot R_f / (R_i + 6)]$$

Class AB: $R_f = 100 \text{ k}\Omega \pm 10\%$

Class D: $R_f = 250 \text{ k}\Omega \pm 10\%$

Shutdown operation

In order to reduce power consumption while not in use, the LPA2110A contains shutdown circuitry to turn off the amplifier's bias circuitry. This shutdown feature turns the amplifier off when logic low is applied to the SD pin.

Power supply decoupling

Power supply leads. For higher frequency transients, spikes, or digital hash on the line, a good low equivalent-series-resistance (ESR) ceramic capacitor, typically 1.0µF, works best, placing it as close as possible to the device VDD terminal. For filtering lower-frequency noise signals, a large capacitor of 20µF (ceramic) and a capacitor of 220µF (electrolytic) are recommended, placing them near the audio power amplifier.

Short Circuit Protection (SCP)

The LPA2110A has short circuit protection circuitry on the outputs to prevent damage to the device when output-to-output or output-to-GND short occurs. When a short circuit is detected on the outputs, the outputs are disabled immediately. If the short was removed, the device activates again.

Input Capacitor (Ci)

C_i for signal input. Large input capacitors are both expensive and space hungry for portable designs. Clearly, a certain sized capacitor is needed to couple in low frequencies without severe attenuation. But in many cases the speakers used in portable systems, whether internal or external, have little ability to reproduce signals below 100Hz to 150Hz. In the typical application, an input capacitor C_i is required to allow the amplifier to bias the input signal to the proper dc level for optimum operation. Thus, using a large input capacitor may not increase actual system performance. In this case, input capacitor (C_i) and input resistance (R_i) of the amplifier form a high-pass filter with the corner frequency determined by equation below,

$$f_c = \frac{1}{2\pi R_i C_i}$$

Over Temperature Protection

Thermal protection on the LPA2110A prevents the device from damage when the internal die temperature exceeds 155°C. There is a $\pm 15^\circ\text{C}$ tolerance on this trip point from device to device.



Once the die temperature exceeds the thermal set point, the device outputs are disabled. This is not a latched fault. The thermal fault is cleared once the temperature of the die is reduced by 20°C. This large hysteresis will prevent motor boating sound well and the device begins normal operation at this point without external system intervention.

How to reduce EMI

A simple solution is to put an additional capacitor at power supply terminal for power line. The traces from amplifier to speakers should design as short as we can. The LPA2110A has been tested with a simple ferrite bead filter for a variety of applications. The LPA2110A EVM passes FCC class-B specifications under these conditions using twisted speaker wires. The size and type of ferrite bead can be selected to meet application requirements. Also, the filter capacitor can be increased if necessary with some impact on efficiency. There may be a few circuit instances where it is necessary to add a complete LC reconstruction filter. These circumstances might occur if there are nearby circuits which are sensitive to noise. In these cases a classic second order Butterworth filter similar to

those shown in the figures below can be used.

Some systems have little power supply decoupling from the AC line but are also subject to line conducted interference (LCI) regulations. These include systems powered by "wall warts" and "power bricks." In these cases, LC reconstruction filters can be the lowest cost means to pass LCI tests. Common mode chokes using low frequency ferrite material can also be effective at preventing line conducted interference.

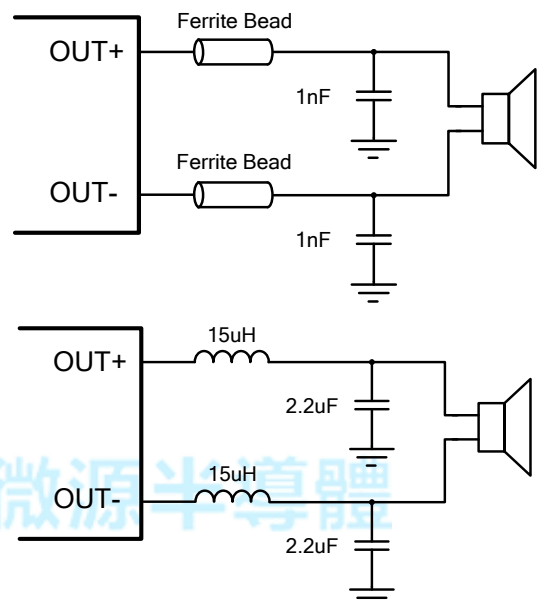



PCB Layout notices

- 1, In the path of the power supply, plus a 1uF and a 10uF to ground high-frequency filter capacitor. These caps can be connected to the thermal pad directly for an excellent ground connection. Consider adding a small, good quality low ESR ceramic capacitor may achieve better sound effects.
- 2, Large (470 μ F or greater) bulk power supply decoupling capacitors should be placed near the LPA2110A on the VDD supplies. Local, high-frequency bypass capacitors should be placed as close to the VDD pins as possible.
- 3, The power line, ground line and filter capacitor and bypass capacitors as close to the chip's pins, remember not to put the capacitor on the back of the board, through tiny holes through the jumper even over. Keep the current loop from each of the outputs through the ferrite bead and the small filter cap and back to GND as small and tight as possible. The size of this current loop determines its effectiveness as an antenna.
- 4, Power, ground, and a large current line must try to be wide enough, if you want to add vias, the number of through-holes must be at least 6. The thermal pad must be soldered to the PCB for proper thermal performance and optimal reliability.
- 5, GND and VDD should be put independently, high-power signals to avoid interference.
- 6, If you want to pursue as large as the effect of power, a large selection of speakers or sound chamber with low resistance (such as 3.6 Ω) speakers, or added to improve the supply voltage.
- 7, Including the line between large current cell and chip, the inductor should be as close and short as possible to chip for a high performance. Adding a coil to this pin would be helpful for EMI certification. If there is a high standards needed in LPA2110A application, we could add a coil and capacitor between chip and speaker constituting a LC filter which coil would be 100MHz, 600 Ω and its DCI beyond 4A placing as close as possible to chip, the capacitor should be 1nF connecting the GND.
- 8, The position under the amplifier chip on the board must be added vents and large areas of exposed copper and tin to enhance heat dissipation.
- 9, In case of fixed gain and meeting demand, it should make C_{IN} small as possible as we can because it constitute a high through filter with R_{in} which cutoff frequency is $1/2 \cdot 3.414 \cdot C_{in} \cdot R_{in}$. A high capacitance cap could make POP worse.



PCB LAYOUT

TOP VIEW:

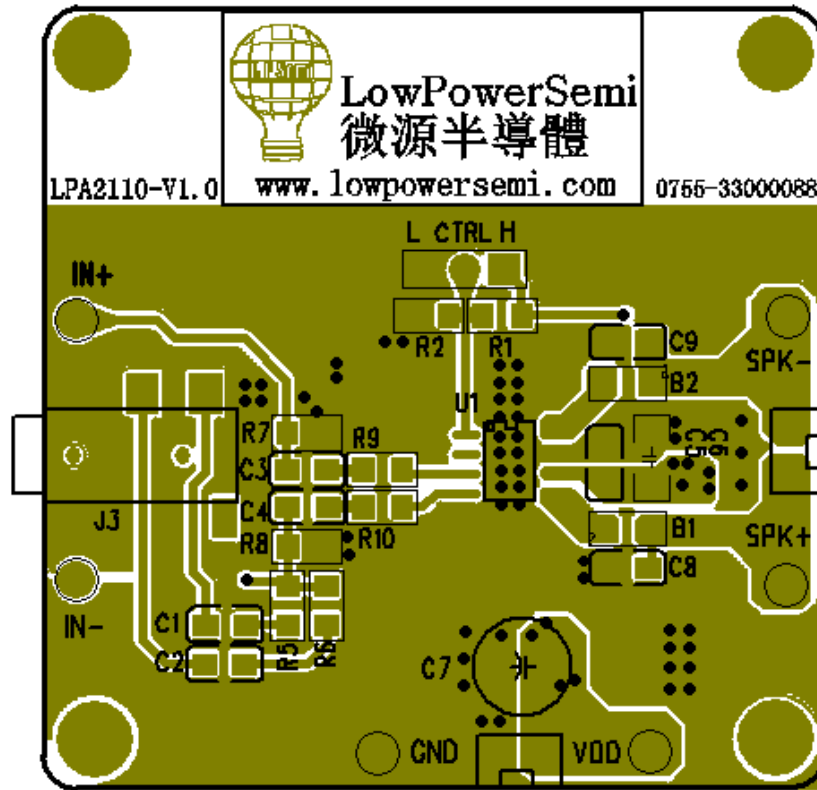

BOTTOM VIEW:

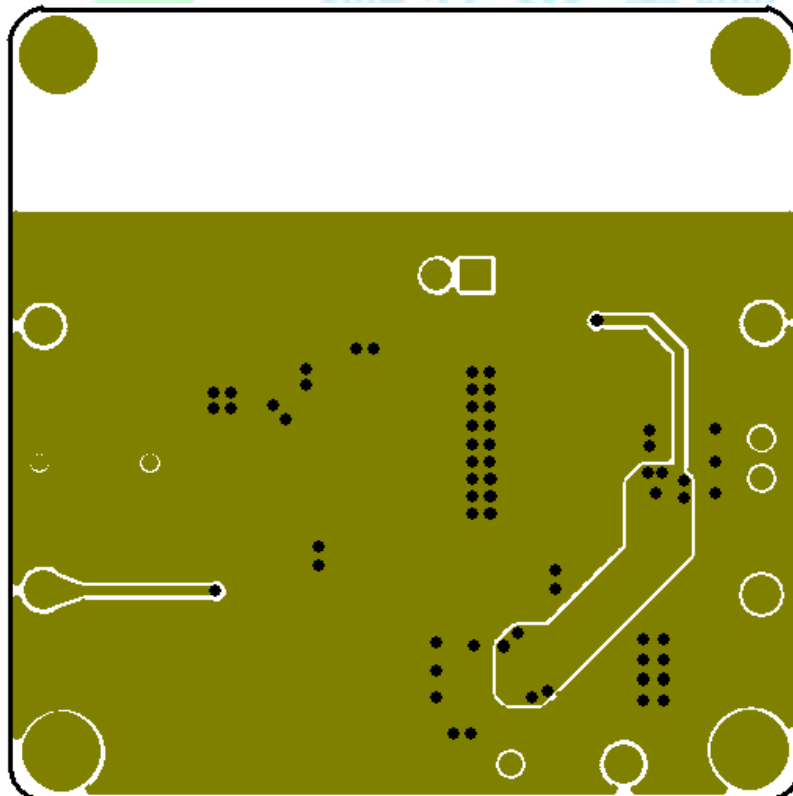



Packaging Information

ESOP-8

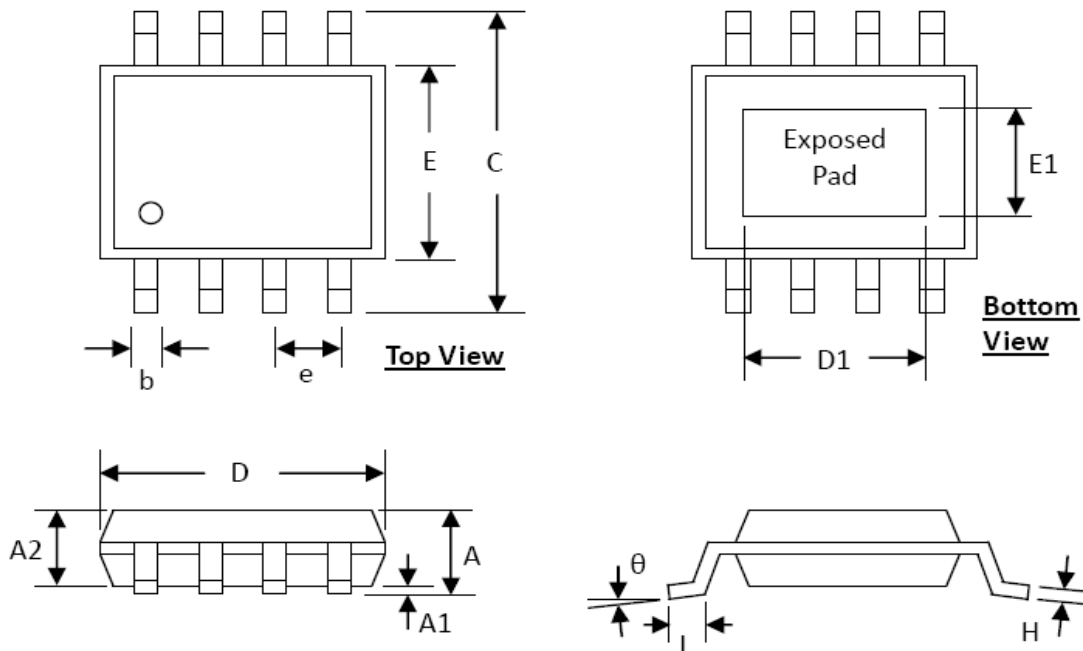

SYMBOLS	DIMENSION (MM)		DIMENSION (INCH)	
	MIN	MAX	MIN	MAX
A	1.30	1.70	0.051	0.067
A1	0.00	0.15	0.000	0.006
A2	1.25	1.52	0.049	0.060
b	0.33	0.51	0.013	0.020
C	5.80	6.20	0.228	0.244
D	4.80	5.00	0.189	0.197
D1	3.15	3.45	0.124	0.136
E	3.80	4.00	0.150	0.157
E1	2.26	2.56	0.089	0.101
e	1.27 BSC		0.050 BSC	
H	0.19	0.25	0.0075	0.0098
L	0.41	1.27	0.016	0.050
θ	0°	8°	0°	8°