

High Efficiency, Low Quiescent, 2A Buck-Boost Converter

General Description

The RT6158A converter is a high efficiency single inductor converter which can operate with wide input voltage 2.5V to 5V such as battery which is higher or lower than the output voltage and it can supply the load current up to 2A. The maximum peak current in the switches is limited to a typical value of 4.5A. Feedback loop is internally compensated for both Buck and Boost operation and it provides seamless transition between Buck and Boost modes and optimal transient response. The Buck-Boost operates at 2MHz typical switching frequency in full synchronous operation.

The RT6158A operates in Pulse Frequency Modulation (PFM) mode for increasing efficiency. The PFM mode can be disabled, forcing the RT6158A to operate at a fixed switching frequency operation at 2MHz. The RT6158A can also be synchronized with external frequency at MODE pin from 2.2MHz to 2.6MHz. The RT6158A output voltage is programmable using an external resistor divider; the output voltage range is from 2.1V to 5.2V.

Applications

- Cellular Telephones
- Wifi Module
- Tablet PC
- Portable Instrument

Features

- **Input Voltage Range : 2.5V to 5V**
- **Adjustable Output Voltage : 2.1V to 5.2V by External Divided Resistors**
- **Up to 2A Maximum Load Capability for $V_{IN} = 3V$, $V_{OUT} = 3.5V$**
- **Up to 96% Efficiency ($V_{IN} = 4.2V$, $V_{OUT} = 3.5V$, $I_{LOAD} = 0.5A$)**
- **OCP, OVP, OTP, UVLO and SCP Function**
- **2MHz Switching Frequency**
- **5 μ A Non-Switching Low Quiescent Current**
- **Forced PWM and Automatic PFM/PWM Mode Selection**
- **Output Fast Discharge Function**
- **Automatic / Seamless Step Up and Step Down Mode Transitions**
- **25-Ball WL-CSP Package**

Ordering Information

RT6158A □
 Package Type
 WSC : WL-CSP-25B 2.07x2.33 (BSC)

Note :

Richtek products are :

- ▶ RoHS compliant and compatible with the current requirements of IPC/JEDEC J-STD-020.
- ▶ Suitable for use in SnPb or Pb-free soldering processes.

Simplified Application Circuit

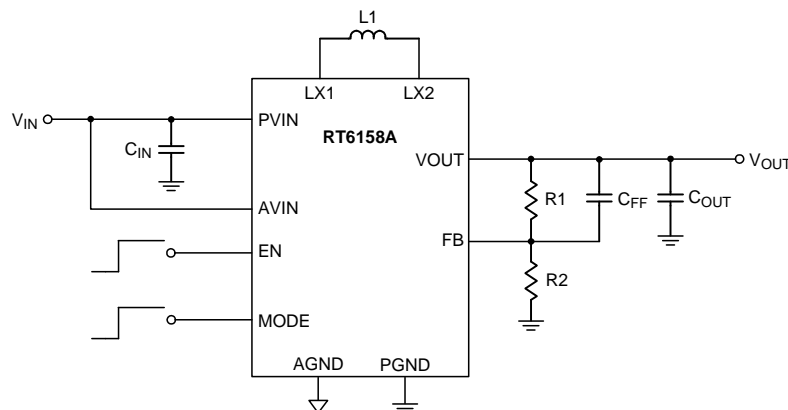

Marking Information

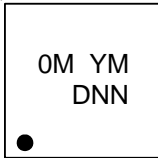

0M : Product Code
YMDNN : Date Code

Pin Configuration

(TOP VIEW)

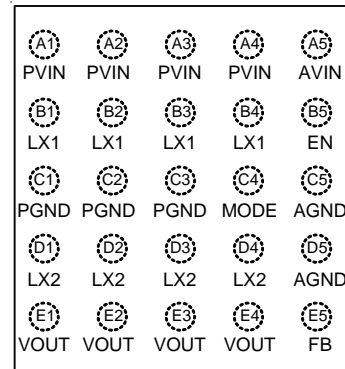

WL-CSP-25B 2.07x2.33 (BSC)

Functional Pin Description

Pin No.	Pin Name	Pin Function
A1, A2, A3, A4	PVIN	Power input supply. The input voltage range is from 2.5V to 5V after soft-start is finished. Connect input capacitors between this pin and PGND with a wide PCB trace.
A5	AVIN	Analog input supply. AVIN Connect to PVIN.
B1, B2, B3, B4	LX1	Switching node 1. Connect to inductor.
B5	EN	Chip enable. This input must not be left floating and must be terminated.
C1, C2, C3	PGND	Power ground. Connect to this pin with the shortest path for power transmission to reduce parasitic component effect.
C4	MODE	High for PFM mode, low for FCCM mode. This pin also can be used to synchronize switching frequency with 2.2MHz to 2.6MHz. This input must not be left floating and must be terminated.
C5, D5	AGND	Analog ground. This is the signal reference ground for the IC.
D1, D2, D3, D4	LX2	Switching node 2. Connect to inductor.
E1, E2, E3, E4	VOUT	Output voltage pin. PCB trace length from VOUT to the output filter capacitor should be as short and wide as possible.
E5	FB	Output voltage feedback. The typical value of the voltage at the FB pin is 800mV.

Functional Block Diagram

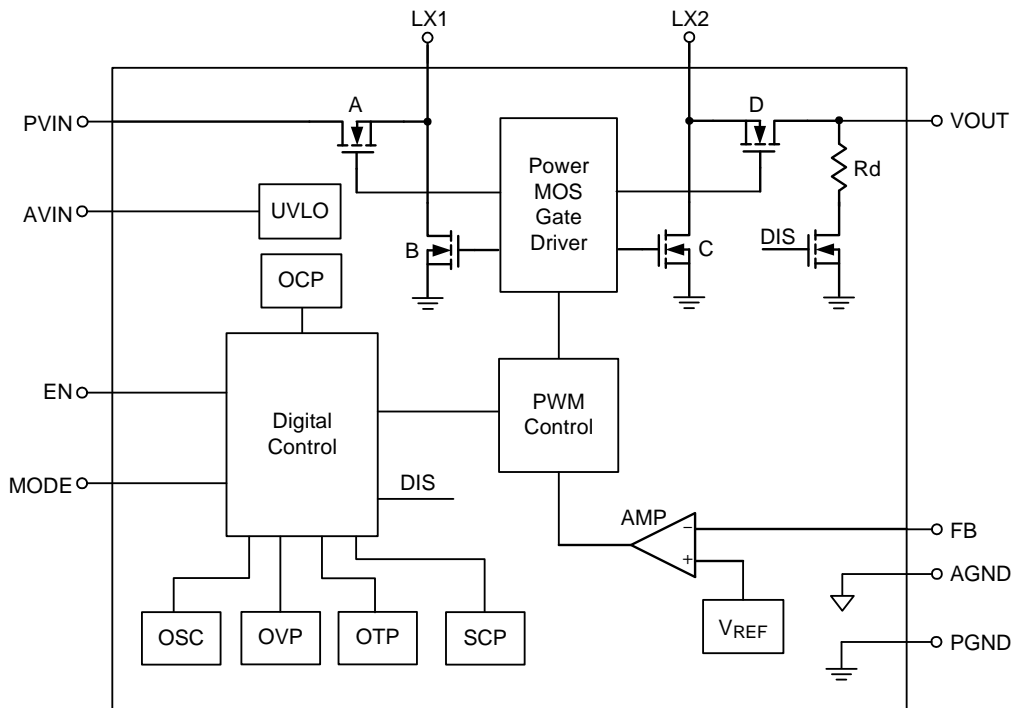

Operation

The RT6158A is a synchronous current mode constant on/off time (CMCOT) switching Buck-Boost converter designed to an adjustable output voltage with an input supply that can be above, equal, or under the output voltage. The inductor current is regulated by a fast current regulator which is controlled by a voltage control loop. The voltage error amplifier gets its feedback input from the FB pin. The output voltage of the RT6158A is

adjustable, and can be set by the external divided resistor. When V_{IN} is greater than V_{OUT} , the device operates in Buck mode. When V_{IN} is lower than V_{OUT} , the device operates in Boost mode. When V_{IN} is close to V_{OUT} , the RT6158A automatically enters Buck or Boost mode. In that case, the converter will maintain the regulation for output voltage and keep a minimum current ripple in the inductor to guarantee good performance.

Absolute Maximum Ratings (Note 1)

- Input Voltage, PVIN, AVIN ----- -0.3V to 6V
- Output Voltage, VOUT ----- -0.3V to 6V
- Switch Node Voltage, LX1, LX2 ----- -0.3V to 6V
 < 20ns ----- -3V to 8.5V
- Other I/O Pins Voltage (EN, MODE, FB) ----- -0.3V to 6V
- Power Dissipation, P_D @ T_A = 25°C
 WL-CSP-25B 2.07x2.33 (BSC) ----- 2.8W
- Package Thermal Resistance (Note 2)
 WL-CSP-25B 2.07x2.33 (BSC), θ_{JA} ----- 35.7°C/W
- Lead Temperature (Soldering, 10 sec.) ----- 260°C
- Junction Temperature ----- 150°C
- Storage Temperature Range ----- -65°C to 150°C
- ESD Susceptibility (Note 3)
 HBM (Human Body Model) ----- 2kV

Recommended Operating Conditions (Note 4)

- Input Voltage, PVIN, AVIN ----- 2.5V to 5V
- Output Voltage, VOUT ----- 2.1V to 5.2V
- Output Current, IOUT ----- 0A to 2A
- Junction Temperature Range ----- -40°C to 125°C
- Ambient Temperature Range ----- -40°C to 85°C

Electrical Characteristics

(V_{IN} = 3.6V, V_{OUT} = 3.5V, C_{IN} = 10μF x 2, C_{OUT} = 10μF x 4, L = 1μH, T_A = 25°C, unless otherwise specified)

Parameter	Symbol	Test Conditions	Min	Typ	Max	Unit
Input Voltage Range	V _{IN}	PVIN and AVIN	2.5	--	5	V
Logic Input High Threshold	V _{IH}		1.2	--	--	V
Logic Input Low Threshold	V _{IL}		--	--	0.4	V
Under-Voltage Lockout	V _{UVLO}	Rising	2.05	2.15	2.25	V
Under-Voltage Lockout Hysteresis	V _{UVLO_H}		0.02	0.1	0.25	V
Shutdown Current	I _{SHDN}	V _{IN} = 3.5V, EN = L	--	--	1	μA
Input Quiescent Current	I _{QVIN}	Non-switching. V _{IN} = 4.2V, V _{OUT} = 3.5V, EN = VIN, Mode = VIN	2	5	8	μA
Switching Quiescent Current	I _{QSW}	I _{LOAD} = 0A. V _{IN} = 4.2V, V _{OUT} = 3.5V, EN = VIN, Mode = VIN	5	8	11	μA
Switching Frequency	f _{SWCOT}	MODE = H, V _{IN} - V _{OUT} > 1V	1	2	2.6	MHz
Switching Frequency	f _{SWCCM}	MODE = L	1.3	2	2.8	MHz
Synchronous Switching Frequency Range	f _{SWSYNC}	MODE = square wave, 10% < duty < 90%	2.2	--	2.6	MHz

Parameter	Symbol	Test Conditions	Min	Typ	Max	Unit
Soft-Start Time	t _{SS_EN}	Time from EN goes H to 90% V _{OUT} starts ramp up	0.3	1	2	ms
	t _{SS}	V _{IN} = 4V, V _{OUT} = 3.5V, I _{LOAD} = 200mA	0.3	1	2	
	t _{SS}	V _{IN} = 2.5V, V _{OUT} = 3.5V, I _{LOAD} = 200mA	0.6	2	4	
Minimum off Time	t _{OFF_MIN}		15	40	65	ns
Minimum on Time	t _{ON_MIN}		25	40	80	ns
FB Voltage		CCM operation	0.792	0.8	0.808	V
High Side Switch On-Resistance	R _{DS_ON_A, D}	V _{OUT} = 5V	12	20	30	mΩ
Low Side Switch On-Resistance	R _{DS_ON_B, C}	V _{OUT} = 5V	12	20	30	mΩ
Output Over-Voltage Protection	V _{OVP}		5.3	5.6	5.9	V
Load Current Threshold, PFM to PWM	I _{TH_PWM}	V _{IN} = 3.6V, V _{OUT} = 3.3V	--	200	--	mA
Load Current Threshold, PWM to PFM	I _{TH_PFM}	V _{IN} = 3.6V, V _{OUT} = 3.3V	--	200	--	mA
FAULT Time	t _{FAULT}		15	40	70	ms
Thermal Shutdown	T _{OTP}	(Note 5)	--	160	--	°C
Over-Temperature Protection Hysteresis	T _{OTP_HYS}	(Note 5)	--	20	--	°C
Inductor Peak Current Limit	I _{CL}		4.3	4.5	5	A
Line Regulation		V _{IN} = 2.5V to 5V, V _{OUT} = 3.5V, CCM, I _{LOAD} = 1.5A	-2	0.6	2	%
Load Regulation		V _{IN} = 2.5V to 5V, V _{OUT} = 3.5V, CCM operation, I _{LOAD} < 2A	-2	0.6	2	%
Line Transient	V _{OUTp-to-p}	V _{IN} = 3V to 3.6V at 10μs, V _{OUT} = 3.5V, I _{LOAD} = 1A	--	100	200	mV
Load Transient		V _{IN} = 3.4V, V _{OUT} = 3.5V, I _{LOAD} = 0.5A to 1A at 1μs	--	250	400	mV

Note 1. Stresses beyond those listed under “Absolute Maximum Ratings” may cause permanent damage to the device. These are stress ratings only, and functional operation of the device at these or any other conditions beyond those indicated in the operational sections of the specifications is not implied. Exposure to absolute maximum rating conditions may affect device reliability.

Note 2. θ_{JA} is measured under natural convection (still air) at T_A = 25°C with the component mounted on a high effective-thermal-conductivity four-layer test board on a JEDEC 51-7 thermal measurement standard.

Note 3. Devices are ESD sensitive. Handling precaution is recommended.

Note 4. The device is not guaranteed to function outside its operating conditions.

Note 5. T_{OTP} and T_{OTP_HYS} are guaranteed by design.

Typical Application Circuit

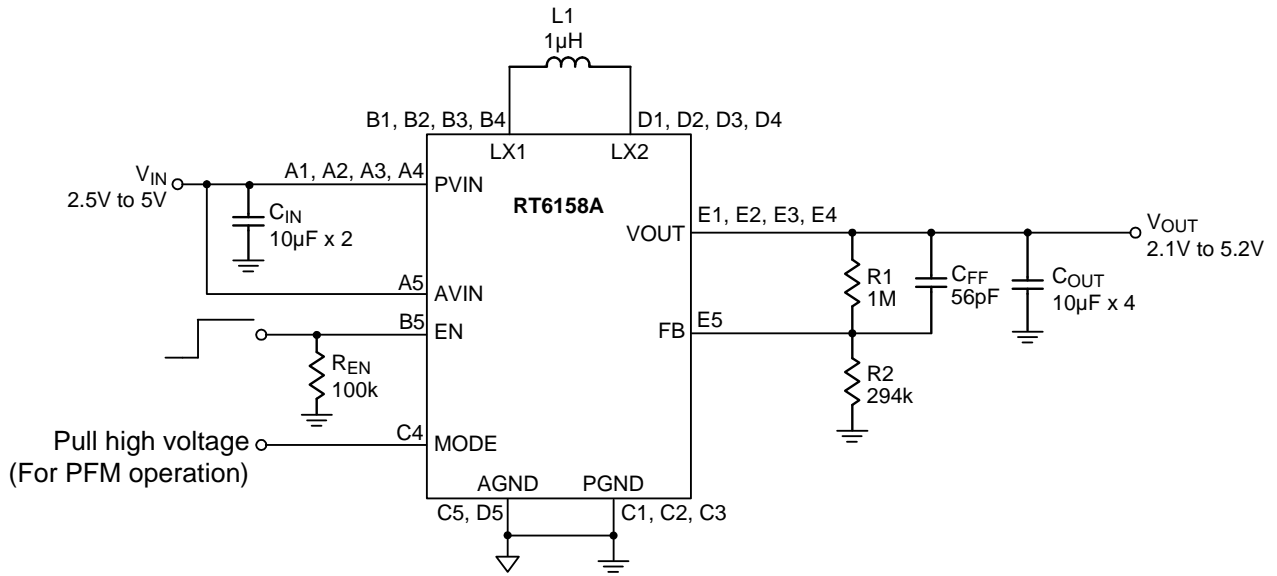

Below are recommended components information

Reference	Part Number	Description	Package	Manufacturer
C _{IN}	GRJ155R60J106ME11D	10µF/6.3V//X5R	0402	MuRata
C _{OUT}	GRJ155R60J106ME11D	10µF/6.3V//X5R	0402	MuRata
C _{FF}	GRM0335C1H560JA01D	56pF/50V/NPO	0201	MuRata
L1	DFE252010F-1R0M = P02	1µH, ±20%	2.5x2x1mm	MuRata

R1	C _{FF}	Application Condition
100kΩ	560pF to 680pF	Load Transient Performance for wifi application requirement (Load condition 50mA to 450mA with slew rate 400mA/µs) Load = 0A to 2A, the system stability
	56pF to 680pF	Load = 0A to 2A, the system stability

Typical Operation Characteristics

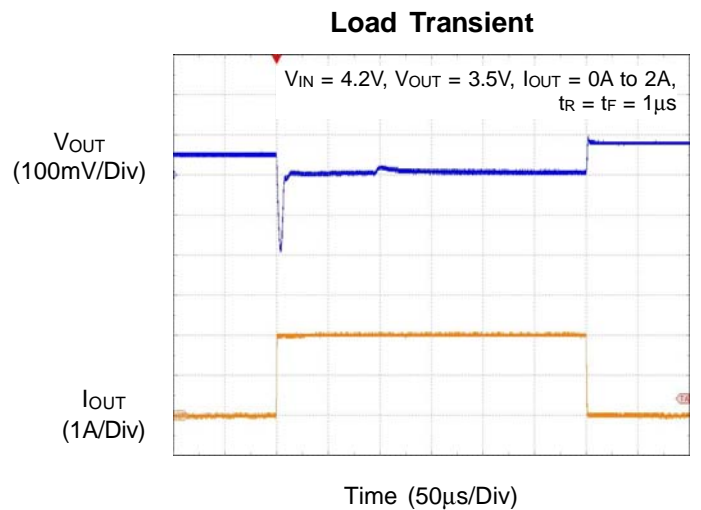
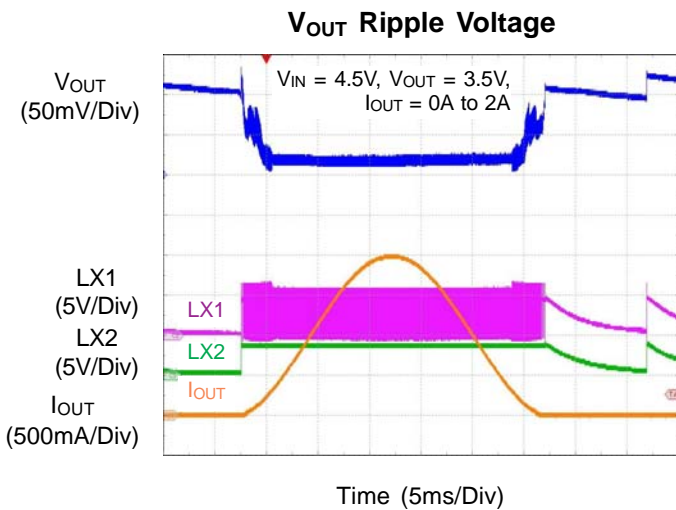
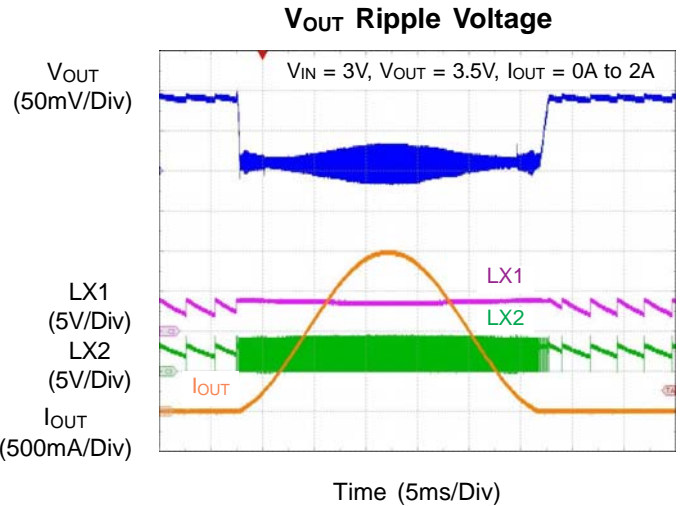
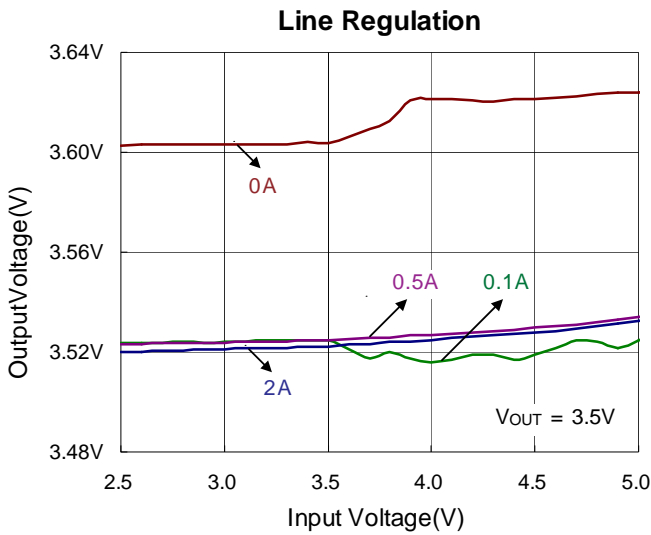
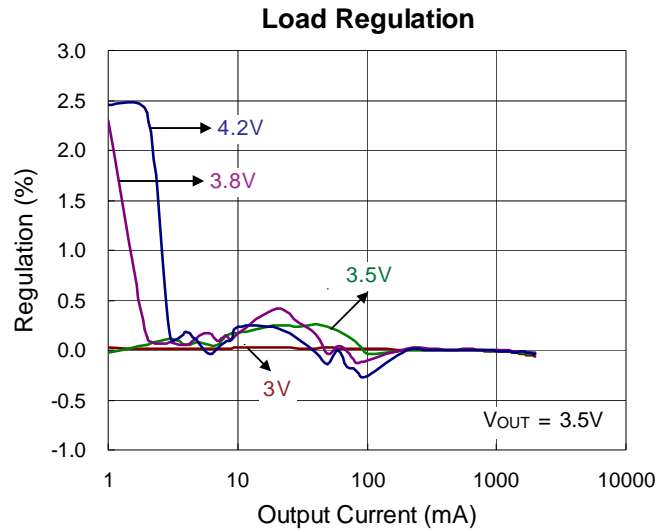
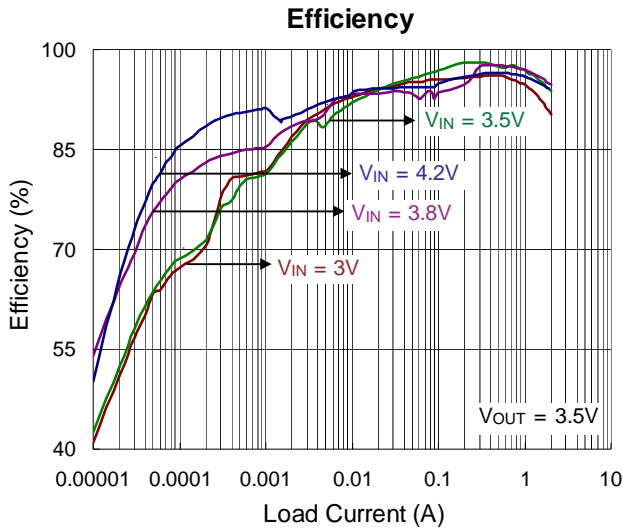

Line Transient

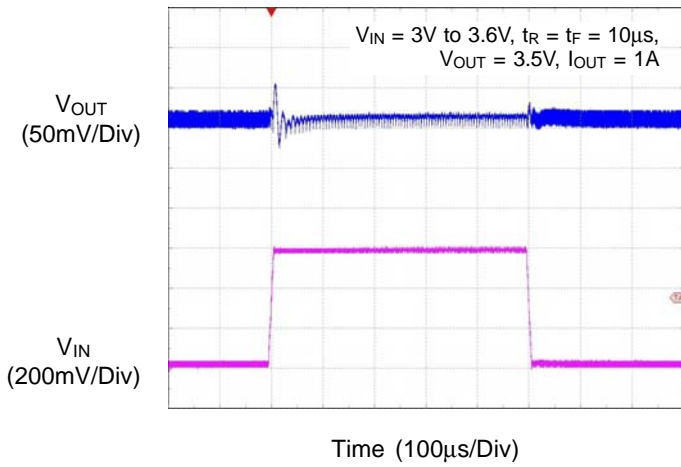

Shutdown Current

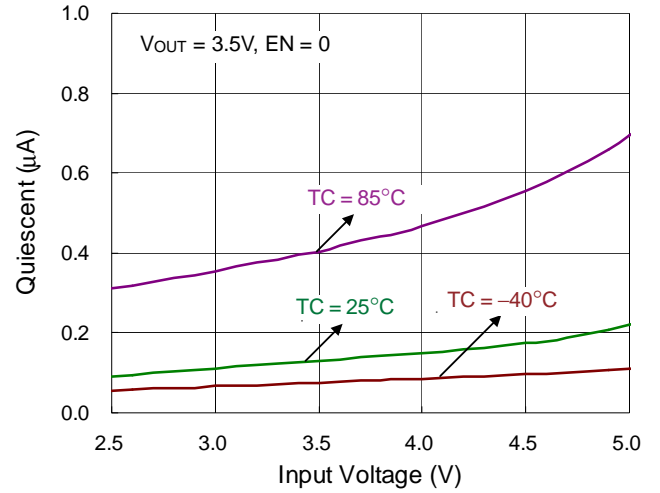

Switching Quiescent Current

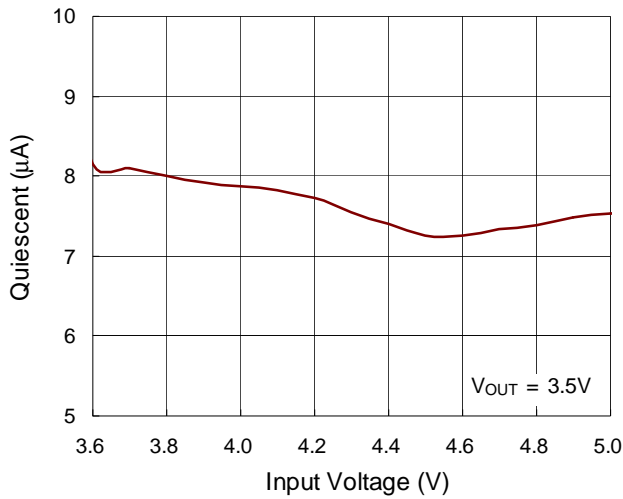

Maximum Output Current vs. Input Voltage

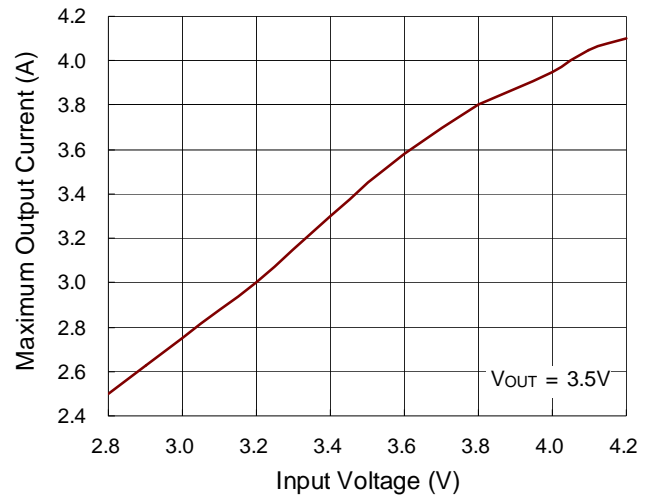

Power On

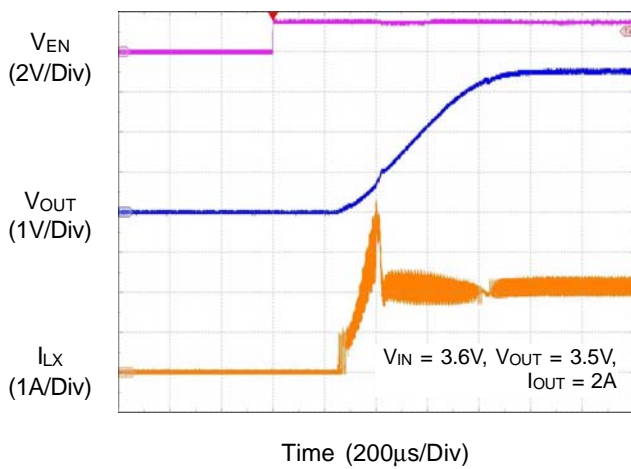

Power Off

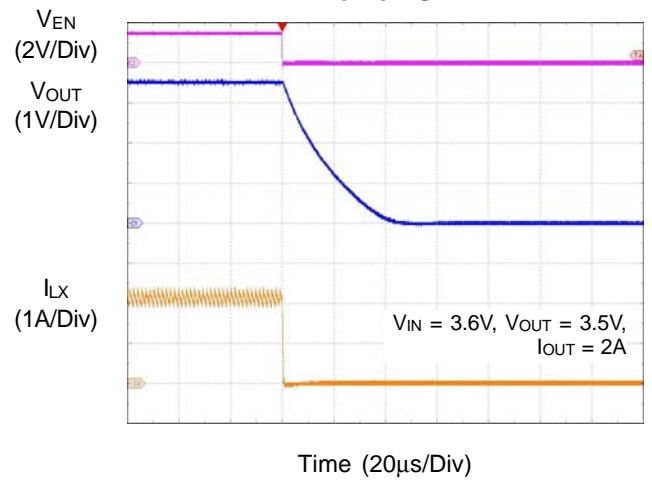

Application Information

The RT6158A Buck-Boost DC-DC converter can operate with wide input voltage such as battery which is higher or lower than the output voltage and it can supply the load current up to 2A. The maximum peak current in the switches is limited to a typical value of 4.5A. The typical operating input voltage is from 2.5V and 5V. The RT6158A output voltage can be set from 2.1V to 5.2V by changing the external divided resistor on the FB pin. The converter feedback loop is internally compensated for both Buck and Boost operation and it provides seamless transition between Buck and Boost modes operation.

Enable

The device can be enabled or by the EN pin. When the EN pin is higher than the threshold of logic high, the device starts operation with soft-start. Once the EN pin is set at low, the device will be shut down. In shutdown mode, the converter stops switching, internal control circuitry is turned off, and the chip enters a low quiescent state for power consumption. The EN pin must not be left floating and must be terminated.

Output Voltage Setting

The RT6158A output voltage can be set from 2.1V to 5.2V by changing the external divided resistor on the FB pin. The resistor divider must be connected between VOUT, FB and GND. The typical value of the voltage at the FB pin is 800mV. For decrease the leakage current on FB pin, it is recommended to keep the resistor R2 with large value. For example, it can be R1 = 1MΩ and R2 = 294kΩ for V_{OUT} = 3.5V application, the following Equation is as below :

$$R1 = R2 \times \left(\frac{V_{OUT}}{V_{FB}} - 1 \right)$$

Dynamic Voltage Scaling Control

The RT6158A output voltage is adjustable via external divided resistors. If there are different output voltages to be switched (DVS) for application during IC operation (EN = H), the maximum output voltage needs to be selected as the 1st setting for start-up.

For example :

$$V_{OUT1} = 3.3V, V_{OUT2} = 5V, V_{OUT3} = 3.8V$$

The maximum output voltage V_{OUT2} needs to be selected as the 1st start-up setting.

MODE states and Synchronization

The MODE pin can be used to select different operation modes. When MODE is set high, it means the RT6158A will operate at PFM mode for used to improve efficiency. At this point the converter operates with reduced switching frequency and with a minimum quiescent current to maintain high efficiency. When the load increases, the device will automatically switch to PWM mode. The PFM mode can be disabled by programming the MODE pin low. Connecting a clock signal at MODE pin can force the RT6158A switching frequency to synchronize to the connected clock frequency. The MODE pin input supports standard logic thresholds and the frequency range is between 2.2MHz to 2.6MHz. The MODE pin must not be left floating and must be terminated.

Under-Voltage Lockout

The under-voltage lockout circuit prevents the device from operating incorrectly at low input voltages. It prevents the converter from turning on the power switches under undefined conditions and prevents the battery from deep discharge. VIN voltage must be greater than 2.15V to enable the converter. During operation, if VIN voltage drops below 2.05V, the converter is disabled until the supply exceeds the UVLO rising threshold. The RT6158A automatically restarts if the input voltage recovers to the input voltage UVLO high level.

Short Circuit Protection

When the output is shorted to ground, the inductor current decays very slowly rate during a single switching cycle. A current runaway detector is used to monitor inductor current. As current increasing beyond the control of current loop, switching cycles will be skipped to prevent current runaway form occurring.

Protection Type	Threshold Refer to Electrical Spec.	Protection Method	Shut Down Delay Time	Reset Method
OCP	$I_L > 4.5A$	Turn on B, D MOS	CL will trigger right away.	$I_L < 4.5A$
UVLO	$V_{IN} < 2.05V$	Shutdown	100 μ s	$V_{IN} > 2.15V$
OTP	TEMP > 160°C	Shutdown	No delay	OTP Hysteresis = 20°C
Output OVP	$V_{OUT} > 5.6V$	Stop switching	No delay	$V_{OUT} < 5.3V$
SCP	$V_{OUT} < 1.2V$	f _{sw} become 1/4	No delay	After FAULT 40ms

Over-Temperature Protection

The device has a built-in temperature sensor which monitors the internal junction temperature. If the temperature exceeds the OTP threshold, the device stops operating and enters shutdown mode. As soon as the IC temperature decreases below the threshold with a hysteresis, it starts operating again.

Over-Voltage Protection

When the V_{OUT} pin is floating, the device will trigger the over-voltage protection to avoid the output voltage exceeding critical values for device. In case it reaches the OVP threshold, the device will regulate the output voltage to this value.

Inductor Selection

The recommended power inductor is 1 μ H with over 4.5A saturation current rating. In applications, it needs to select an inductor with the low DCR for good performance and efficiency.

Input and Output Capacitor Selection

The input and output capacitors should be ceramic X5R type with low ESL and ESR. The recommended input capacitor value is 2 x 10 μ F. The recommended output capacitor value is 4 x 10 μ F.

The output capacitor selection determines the output voltage ripple and transient response. It is recommended to use ceramic capacitors placed as close as possible to the V_{OUT} and GND pins of the IC. If, for any reason, the application requires the use of large capacitors which cannot be placed close to the IC, using a small ceramic capacitor in parallel to the large one is recommended. This small capacitor should be placed as close as possible to the V_{OUT} and GND pins of the IC.

If the RT6158A operates in Buck mode, the worst-case voltage ripple occurs at the highest input voltage. When the Buck-boost operates in Boost mode, the worst-case voltage ripple occurs at the lowest input voltage. A capacitor with a value in the range of the calculated minimum should be used. This is required to maintain control loop stability. There are no additional requirements regarding minimum ESR. Low ESR capacitors should be used to minimize output voltage ripple. Larger capacitors will cause lower output voltage ripple as well as lower output voltage drop during load transients.

Thermal Considerations

The junction temperature should never exceed the absolute maximum junction temperature T_{J(MAX)}, listed under Absolute Maximum Ratings, to avoid permanent damage to the device. The maximum allowable power dissipation depends on the thermal resistance of the IC package, the PCB layout, the rate of surrounding airflow, and the difference between the junction and ambient temperatures. The maximum power dissipation can be calculated using the following formula :

$$P_{D(MAX)} = (T_{J(MAX)} - T_A) / \theta_{JA}$$

where T_{J(MAX)} is the maximum junction temperature, T_A is the ambient temperature, and θ_{JA} is the junction-to-ambient thermal resistance.

For continuous operation, the maximum operating junction temperature indicated under Recommended Operating Conditions is 125°C. The junction-to-ambient thermal resistance, θ_{JA} , is highly package dependent. For a WL-CSP-25B 2.07x2.33 (BSC) package, the thermal resistance, θ_{JA} , is 35.7°C/W on a standard JEDEC 51-7 high effective-thermal-conductivity four-layer test board.

The maximum power dissipation at $T_A = 25^\circ\text{C}$ can be calculated as below :

$$P_{D(\text{MAX})} = (125^\circ\text{C} - 25^\circ\text{C}) / (35.7^\circ\text{C}/\text{W}) = 2.8\text{W for a WL-CSP-25B } 2.07 \times 2.33 \text{ (BSC) package.}$$

The maximum power dissipation depends on the operating ambient temperature for the fixed $T_{J(\text{MAX})}$ and the thermal resistance, θ_{JA} . The derating curves in Figure 1 allows the designer to see the effect of rising ambient temperature on the maximum power dissipation.

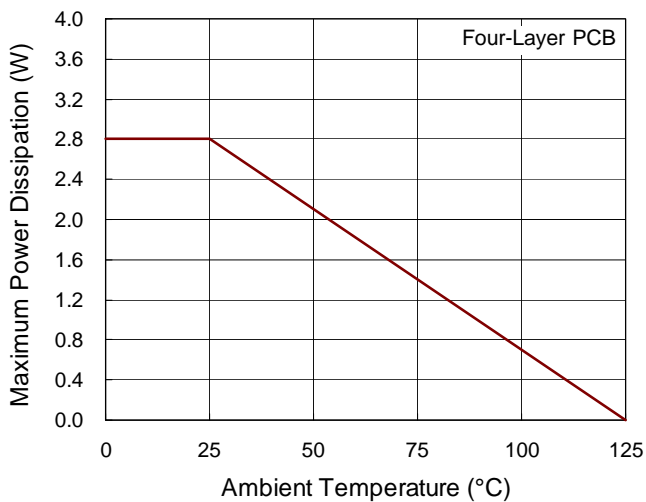

Figure 1. Derating Curve of Maximum Power Dissipation

Layout Considerations

Some PCB layout guidelines for optimal performance of the RT6158A list as following. Following figure shows the real PCB layout considerations and it is based on the real component size whose unit is millimeter (mm).

- ▶ The input capacitor should be placed as closed as possible to PVIN pin for good filtering.
- ▶ The high current path should be made as short and wide as possible.
- ▶ The inductor should be placed as close to LX1 and LX2 pin for reducing EMI.
- ▶ The output capacitor should be placed as closed as PGND pin to ground plane to reduce noise coupling.

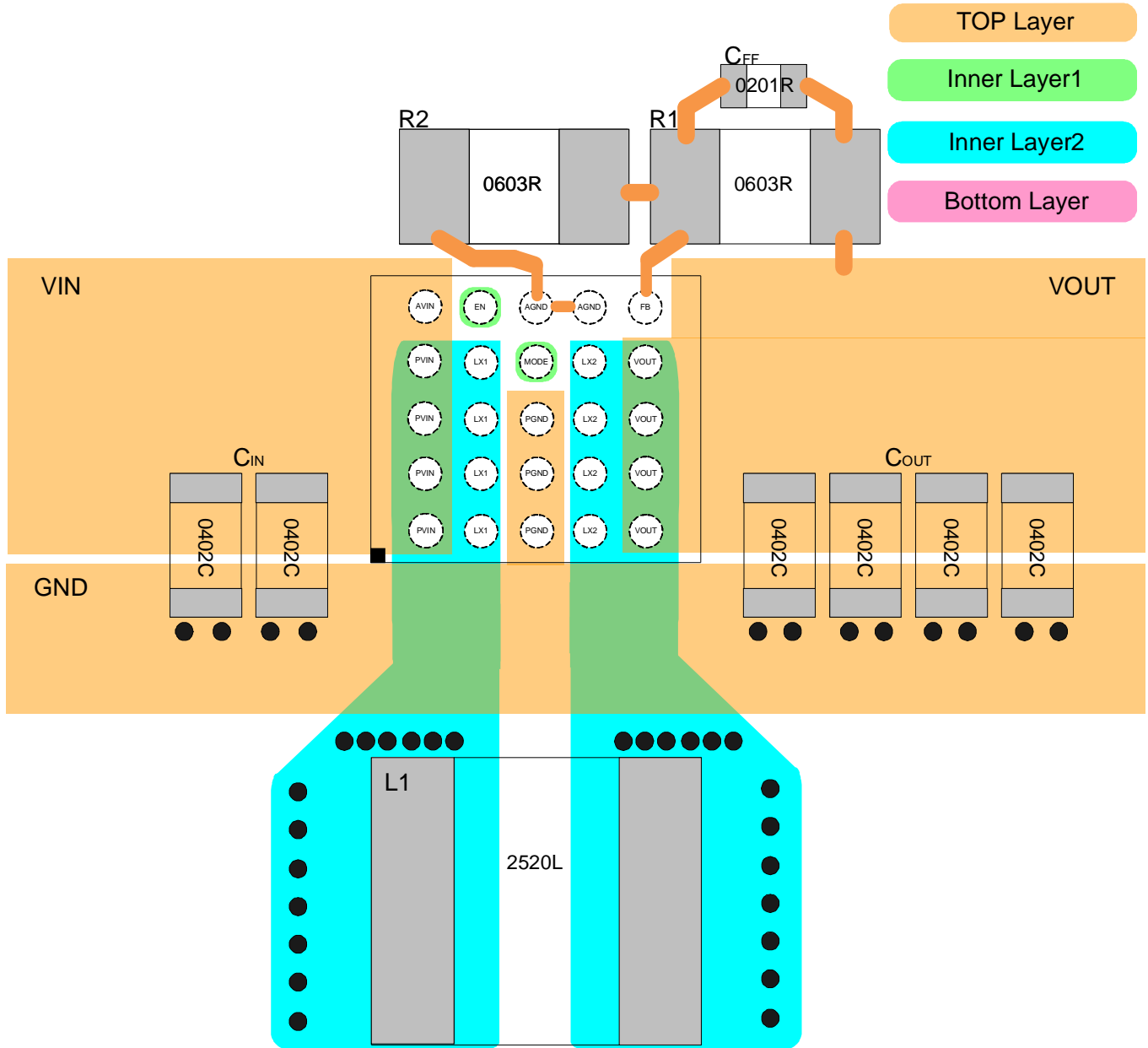
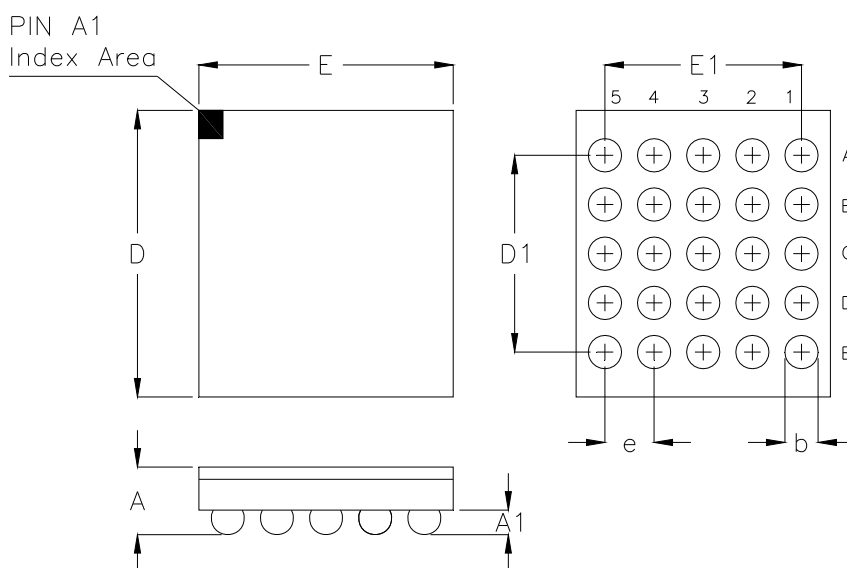

Figure 2. PCB Layout Guide

Outline Dimension



Symbol	Dimensions In Millimeters		Dimensions In Inches	
	Min	Max	Min	Max
A	0.500	0.600	0.020	0.024
A1	0.170	0.230	0.007	0.009
b	0.240	0.300	0.009	0.012
D	2.280	2.380	0.090	0.094
D1	1.600		0.063	
E	2.020	2.120	0.080	0.083
E1	1.600		0.063	
e	0.400		0.016	

25B WL-CSP 2.07x2.33 Package (BSC)

Footprint Information

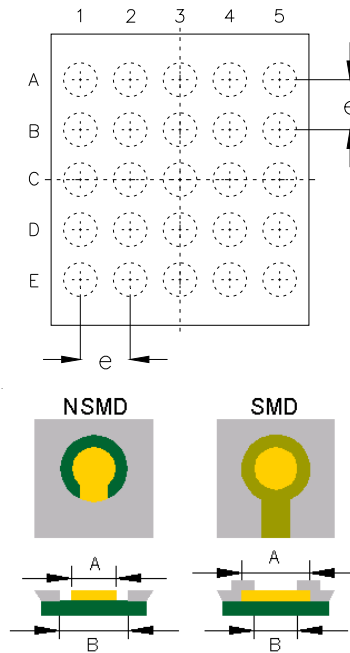

Package	Number of Pin	Type	Footprint Dimension (mm)			Tolerance
			e	A	B	
WL-CSP2.07*2.33-25(BSC)	25	NSMD	0.400	0.240	0.340	±0.025
		SMD		0.270	0.240	

Richtek Technology Corporation

14F, No. 8, Tai Yuen 1st Street, Chupei City
 Hsinchu, Taiwan, R.O.C.
 Tel: (8863)5526789

Richtek products are sold by description only. Richtek reserves the right to change the circuitry and/or specifications without notice at any time. Customers should obtain the latest relevant information and data sheets before placing orders and should verify that such information is current and complete. Richtek cannot assume responsibility for use of any circuitry other than circuitry entirely embodied in a Richtek product. Information furnished by Richtek is believed to be accurate and reliable. However, no responsibility is assumed by Richtek or its subsidiaries for its use; nor for any infringements of patents or other rights of third parties which may result from its use. No license is granted by implication or otherwise under any patent or patent rights of Richtek or its subsidiaries.

Mouser Electronics

Authorized Distributor

Click to View Pricing, Inventory, Delivery & Lifecycle Information:

[Richtek:](#)

[RT6158AWSC](#)