

P.C.B LAYOUT

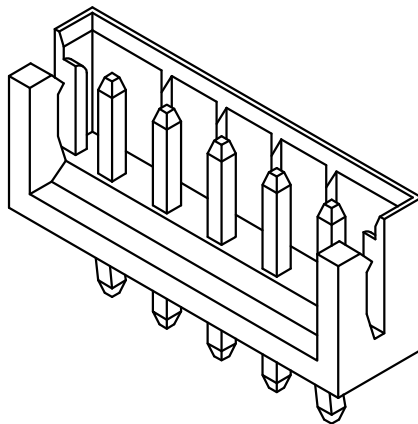

SPECIFICATIONS

Voltage Rating: 250V AC/DC
 Current Rating: 3A AC/DC
 Withstanding Voltage: 800V AC/minute
 Insulation Resistance: 1000MΩ min.
 Temperature Range: -25° C - +85° C
 Contact Resistance: 20mΩ max

WAFER

Part No: SCT2511WV-XXP
 Poles: 2-15
 Material: Nylon 66, UL94V-0
 Pin: Brass, Tin plated

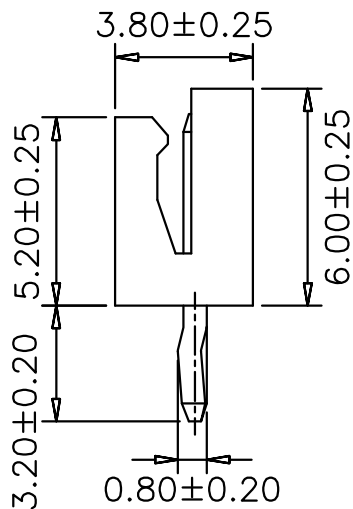
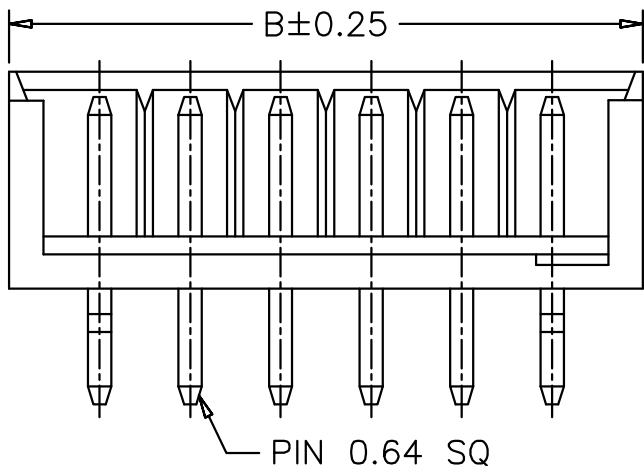
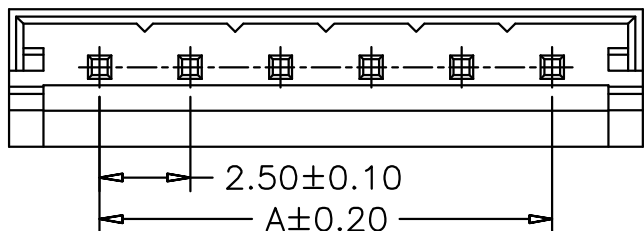

PART NO.	Dimensions	
	A	B
SCT2511WV-02P	2.50	7.50
SCT2511WV-03P	5.00	10.00
SCT2511WV-04P	7.50	12.50
SCT2511WV-05P	10.00	15.00
SCT2511WV-06P	12.50	17.50
SCT2511WV-07P	15.00	20.00
SCT2511WV-08P	17.50	22.50
SCT2511WV-09P	20.00	25.00
SCT2511WV-10P	22.50	27.50
SCT2511WV-11P	25.00	30.00
SCT2511WV-12P	27.50	32.50
SCT2511WV-13P	30.00	35.00
SCT2511WV-14P	32.50	37.50
SCT2511WV-15P	35.00	40.00

					OPERATION	DRAW	CHENA	05/12/27	SCALE		森康达电子有限公司 S'CONDAR ELECTRONIC LIMITED	
					~ 10 ±0.15	DESIGN			UNIT	mm		
					20 ~ 30 ±0.30	CHECK	MICKY	05/12/27	SIZE	A4	PART NO.	SCT2511WV-XXP
0	05/12/27				30 ~ ±0.50	APPROVE	HELLEN	05/12/27	SHEET	1/1	TITLE:	EH2.5 180C Wafer
REV	DATE	MODIFICATION DESCRIPTION	CHANGE	APPROVE	Angle DIM				PROJ.	◆	DRAWING NO.	SCT2511