

THIS DRAWING IS UNPUBLISHED. RELEASED FOR PUBLICATION, 19
 © COPYRIGHT 19 BY AMP INCORPORATED. ALL INTERNATIONAL RIGHTS RESERVED.

LOC	DIST	P	F	REVISIONS				
AF	50			ZONE	LTR	DESCRIPTION	DATE	APPD
					K	REV PER 0710-0057-95	2/16/95	JR JW

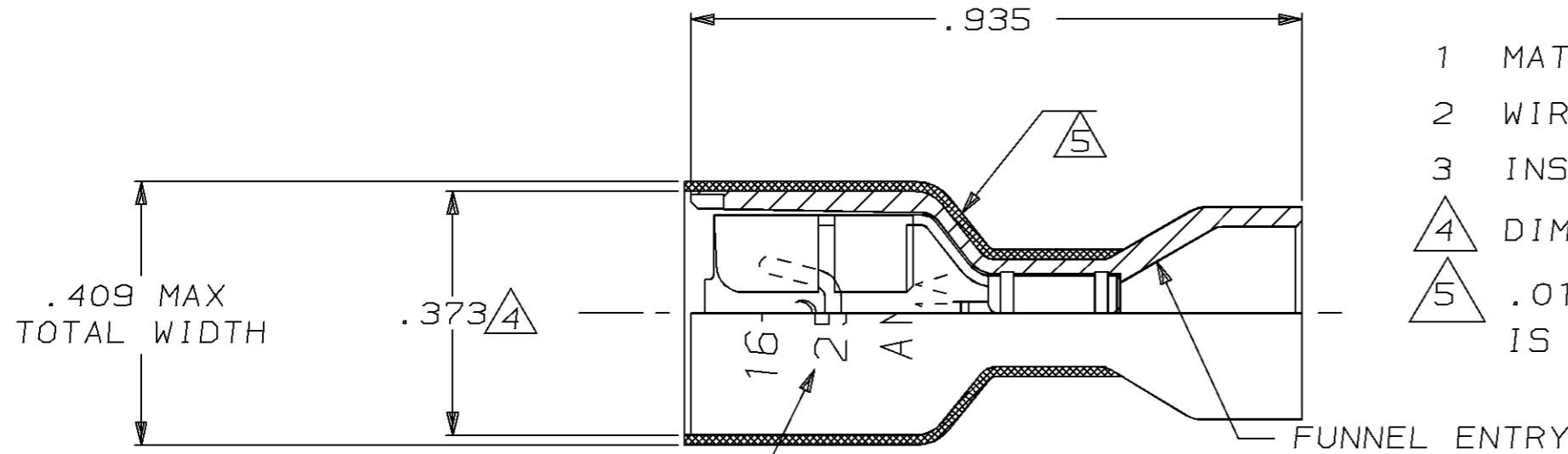

- 1 MATES WITH .032±.001×.250 TAB, PER NEMA DC-2
- 2 WIRE STRIP LENGTH .281
- 3 INSULATION SIZE .260 MAX DIA
- △4 DIMENSION DOES NOT INCLUDE TRIM BURR
- △5 .015 MAX CARRIER TRIM BURR PER SIDE IS ALLOWABLE IN THE SHADED AREA

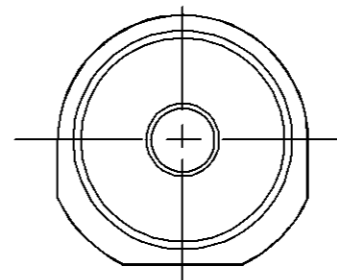
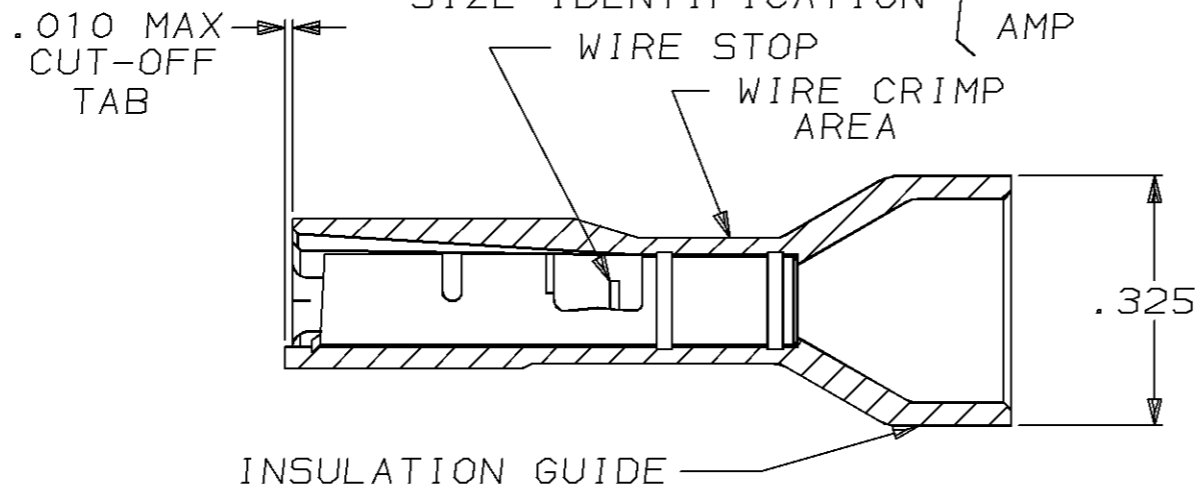
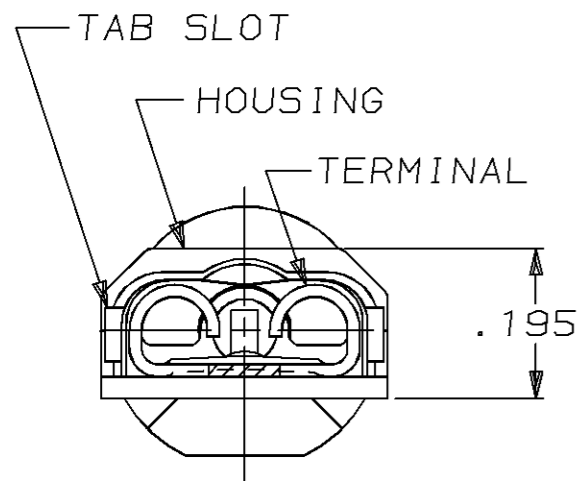

HOUSING: NYLON, COLOR-BLUE TRANSLUCENT		3-520141-2	
RECEPTACLE: #3 HARD BRASS, TIN .000080 MIN		PART NO	
MATERIAL & FINISH		AMP INCORPORATED Harrisburg, Pa. 17105	
DO NOT SCALE PRINT. UNLESS SPECIFIED DIMENSIONS IN INCHES. TOLERANCES ON: 2 PLC DEC ± - 3 PLC DEC ± .015 ANGLES ± -		NAME RECEPTACLE ASSY, ULTRA-FAST, LOOSE PIECE, .250 SERIES, 16-14 AWG	
MATERIAL SEE TABLE		SIZE B	
FINISH SEE TABLE		FSCM NO 00779	
DR 10/18/88 P FORTNEY		DRAWING NO 520141	
CHK 10/18/88 JR RUTH		SCALE 4:1	
APPD 10/21/88 K RANDOLPH		SHEET 1 OF 1	
APPD 10/21/88 TL SHUTTER			
PRODUCT SPEC 108-2043			
APPLICATION SPEC 114-2123			
WEIGHT -			