



MPQ4436B

45V, 6A, Low- I_Q , Synchronous Step-Down Converter, AEC-Q100 Qualified

DESCRIPTION

The MPQ4436B is a configurable-frequency, synchronous, step-down switching regulator with integrated internal high-side and low-side power MOSFETs (HS-FET and LS-FET, respectively). It provides up to 6A of highly efficient output current (I_{OUT}), with current mode control for fast loop response.

The wide 3.3V to 45V input voltage (V_{IN}) range accommodates a variety of step-down applications in automotive input environments. A 1.7 μ A shutdown mode quiescent current (I_Q) allows the part to be used in battery-powered applications.

High power conversion efficiency across a wide load range is achieved by scaling down the switching frequency (f_{SW}) under light-load conditions to reduce the switching and gate driver losses.

An open-drain power good (PG) signal indicates whether the output is within 95% to 105% of its nominal voltage.

Frequency foldback helps prevent inductor current runaway during start-up. Thermal shutdown provides reliable, fault-tolerant operation. High duty cycle and low-dropout mode are provided for automotive cold-crank conditions.

The MPQ4436B is available in a QFN-20 (4mmx4mm) package.

FEATURES

- Wide 3.3V to 45V Operating Input Voltage (V_{IN}) Range
- 6A Continuous Output Current (I_{OUT})
- 1.7 μ A Low Shutdown Supply Current
- 18 μ A Sleep Mode Quiescent Current (I_Q)
- Internal 48m Ω High-Side MOSFET (HS-FET) and 20m Ω Low-Side MOSFET (LS-FET)
- 350kHz to 1000kHz Configurable Switching Frequency (f_{SW}) for $V_{OUT} < 5V$ Car Battery Applications
- Up to 2.2MHz Configurable f_{SW} for $V_{OUT} \geq 5V$ Car Battery Applications
- Synchronizable to an External Clock
- Multi-Phase Capability
- Out-of-Phase Synchronized Clock Output
- Symmetric V_{IN} for Low EMI
- Power Good (PG) Output
- External Soft Start (SS)
- 100ns Minimum On Time
- Selectable Advanced Asynchronous Modulation (AAM) Mode or Forced Continuous Conduction Mode (FCCM)
- Low-Dropout Mode
- Hiccup Over-Current Protection (OCP)
- Available in a QFN-20 (4mmx4mm) Package
- Available in a Wettable Flank Package
- Available in AEC-Q100 Grade 1

APPLICATIONS

- Automotive Infotainment
- Automotive Clusters
- Automotive Telematics
- Industrial Power Systems

All MPS parts are lead-free, halogen free, and adhere to the RoHS directive. For MPS green status, please visit the MPS website under Quality Assurance. "MPS", the MPS logo, and "Simple, Easy Solutions" are registered trademarks of Monolithic Power Systems, Inc. or its subsidiaries.

TYPICAL APPLICATION

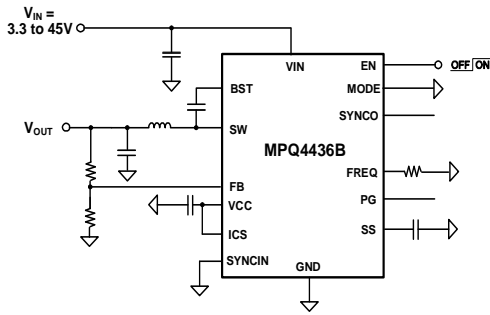

Efficiency vs. Load Current
 $V_{OUT} = 5V$, $f_{sw} = 470kHz$, AAM mode, $L = 4.7\mu H$ (DCR = $15m\Omega$)

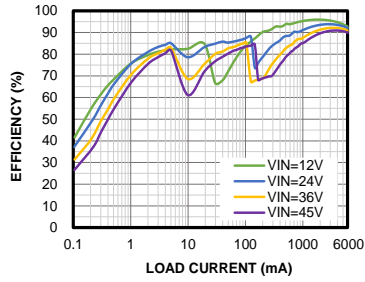

Efficiency vs. Load Current
 $V_{OUT} = 5V$, $f_{sw} = 2.2MHz$, AAM mode, $L = 1\mu H$ (DCR = $8.5m\Omega$)

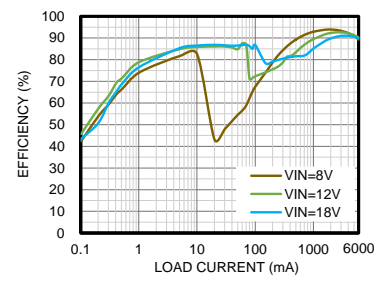

ORDERING INFORMATION

| Part Number* | Package | Top Marking | MSL Rating** |
|---------------------|------------------|------------------|--------------|
| MPQ4436BGRE-AEC1*** | QFN-20 (4mmx4mm) | <i>See Below</i> | 1 |
| MPQ4436BGRE*** | QFN-20 (4mmx4mm) | <i>See Below</i> | 1 |

* For Tape & Reel, add suffix -Z (e.g. MPQ4436BGRE-AEC1-Z).

**Moisture Sensitivity Level Rating

***Wettable Flank

TOP MARKING

MPSYWW

M4436B

LLLLLL

E

MPS: MPS prefix
 Y: Year code
 WW: Week code
 M4436B: Part number
 LLLLLL: Lot number
 E: Wettable flank

PACKAGE REFERENCE

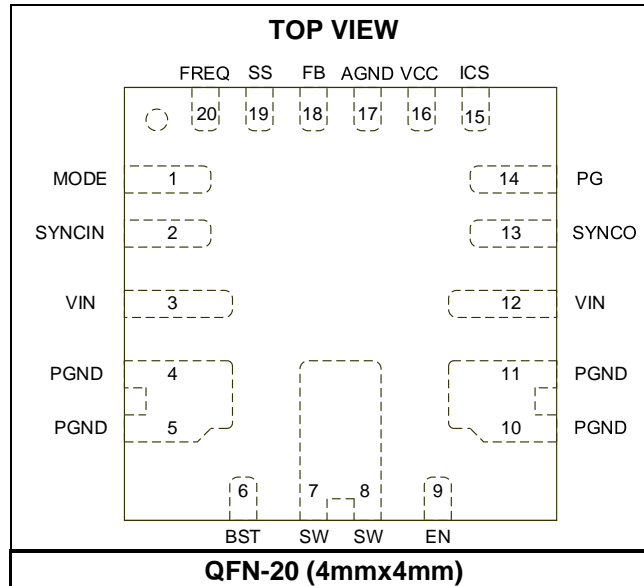

PIN FUNCTIONS

| Pin # | Name | Description |
|--------------|--------|--|
| 1 | MODE | AAM or FCCM selection pin. Pull this pin high to put the part in forced continuous conduction mode (FCCM). Pull it low to make the part operate in advanced asynchronous modulation (AAM) mode under light loads. Do not leave this pin floating. |
| 2 | SYNCIN | SYNC input. Apply a 350kHz to 2.2MHz clock signal to this pin to synchronize the internal oscillator frequency to the external clock (except for $V_{OUT} < 5V$ applications). This pin is also used for multi-phase operation. Do not float this pin under any circumstances. The pin is internally high-impedance. If used, ensure that the external sync clock has adequate pull-up and pull-down capability. It is recommended to place a $\leq 51k\Omega$ resistor between this pin and GND in case the external sync clock pull-down capability is not strong enough or the pin enters a high-impedance (Hi-Z) state. |
| 3, 12 | VIN | Input supply. VIN supplies power to all of the internal control circuitry and the power MOSFET connected to SW. It is recommended to place a decoupling capacitor to ground close to VIN to minimize switching spikes. |
| 4, 5, 10, 11 | PGND | Power ground. |
| 6 | BST | Bootstrap. BST is the positive power supply for the high-side MOSFET (HS-FET) driver connected to SW. Connect a bypass capacitor between BST and SW. See the Application Information section on page 37 to calculate the size of this capacitor. |
| 7, 8 | SW | Switch node. SW is the output of the internal power MOSFET. |
| 9 | EN | Enable. Pull this pin below 0.85V to shut down the chip. Pull it above 1V to enable the chip. |
| 13 | SYNCO | SYNC output. This pin outputs a clock signal that is 180° out of phase with the internal oscillator signal, or 180° out of phase with the clock signal applied at SYNCIN pin. Leave this pin floating if not used. |
| 14 | PG | Power good (PG) indicator. PG's output is an open drain. A pull-up resistor connected to the power source is required if PG is used. If the output voltage (V_{OUT}) is within 95% to 105% of the nominal voltage, this pin goes high. If V_{OUT} is above 106.5% or below 93.5% of the nominal voltage, this pin goes low. |
| 15 | ICS | Current-sharing pin. In a multi-phase application, connect the ICS pin of the chips in parallel to improve current sharing between different phases. Connect ICS to the VCC pin or V_{OUT} (which must be at least 3V) in a single-phase application. Do not float this pin. |
| 16 | VCC | Bias supply. This pin supplies 4.9V to the internal control circuit and gate drivers. A decoupling capacitor to ground is required close to this pin. See the Application Information section on page 37 to calculate the size of this capacitor. |
| 17 | AGND | Analog ground. |
| 18 | FB | Feedback input. To set V_{OUT} , connect FB to the center point of the external resistor divider that is between the output and AGND. The feedback threshold voltage is 0.815V. Place the resistor divider as close to FB as possible. Avoid placing vias on the FB traces. |
| 19 | SS | Soft start (SS) input. Place a capacitor from SS to GND to set the soft-start time (t_{SS}). The MPQ4436B sources 6 μ A from SS to the soft-start capacitor (C_{SS}) at start-up. As the SS voltage (V_{SS}) rises, the feedback threshold voltage increases to limit inrush current during start-up. |
| 20 | FREQ | Switching frequency setting. Connect a resistor from this pin to GND to set the switching frequency (f_{SW}). See the f_{SW} vs. R_{FREQ} curve in the Typical Performance Characteristics section on page 15 to set the frequency. |

ABSOLUTE MAXIMUM RATINGS ⁽¹⁾

| | |
|---|---------------------------------------|
| VIN, EN | -0.3V to +50V |
| SW | -0.3V to V _{IN (MAX)} + 0.3V |
| BST | V _{SW} + 5.5V |
| All other pins..... | -0.3V to +5.5V |
| Continuous power dissipation (T _A = 25°C) ^{(2) (4)} | |
| QFN-20 (4mmx4mm) | 5.4W |
| Operating junction temperature..... | 150°C |
| Lead temperature | 260°C |
| Storage temperature..... | -65°C to +150°C |

ESD Ratings

| | |
|----------------------------------|--------|
| Human body model (HBM) | ±2000V |
| Charged device model (CDM) | ±750V |

Recommended Operating Conditions

| | |
|--|----------------------------------|
| Supply voltage (V _{IN}) | 3.3V to 45V |
| Output voltage (V _{OUT}) | 0.815V to 0.95 x V _{IN} |
| Operating junction temp (T _J) | -40°C to +150°C |

Thermal Resistance
θ_{JA} θ_{JC}

| | | |
|-------------------------------------|---------|-----------|
| QFN-20 (4mmx4mm) | | |
| JESD51-7 ⁽³⁾ | 44..... | 9....°C/W |
| EVQ4436B-R-00A ⁽⁴⁾ | 23..... | 2.5..°C/W |

Notes:

- 1) Exceeding these ratings may damage the device.
- 2) The maximum allowable power dissipation is a function of the maximum junction temperature T_J (MAX), the junction-to-ambient thermal resistance θ_{JA}, and the ambient temperature T_A. The maximum allowable continuous power dissipation at any ambient temperature is calculated by P_D (MAX) = (T_J (MAX) - T_A) / θ_{JA}. Exceeding the maximum allowable power dissipation can cause excessive die temperature, and the regulator may go into thermal shutdown. Internal thermal shutdown circuitry protects the device from permanent damage.
- 3) Measured on JESD51-7, 4-layer PCB. The values given in this table are only valid for comparison with other packages and cannot be used for design purposes. These values were calculated in accordance with JESD51-7, and simulated on a specified JEDEC board. They do not represent the performance obtained in an actual application.
- 4) Measured on the EVQ4436B-R-00A, a 9cmx9cm, 2oz, 4-layer PCB.

ELECTRICAL CHARACTERISTICS

V_{IN} = 12V, V_{EN} = 2V, T_J = -40°C to +125°C, typical values are at T_J = 25°C, unless otherwise noted.

| Parameter | Symbol | Condition | Min | Typ | Max | Units |
|---|------------------------------|---|-------|------|-------|-------|
| V _{IN} under-voltage lockout (UVLO) rising threshold | V _{IN_UVLO_RISING} | | 2.8 | 3 | 3.2 | V |
| V _{IN} UVLO falling threshold | V _{IN_UVLO_FALLING} | | 2.5 | 2.7 | 2.9 | V |
| V _{IN} UVLO hysteresis | V _{IN_UVLO_HYS} | | | 280 | | mV |
| VCC voltage | V _{CC} | I _{VCC} = 0A | 4.6 | 4.9 | 5.2 | V |
| VCC regulation | | I _{VCC} = 30mA | | 1 | 4 | % |
| VCC current limit | I _{LIMIT_VCC} | V _{CC} = 4V | 100 | | | mA |
| V _{IN} quiescent current | I _Q | FB = 0.85V, no load, (sleep mode) | | 18 | 26 | μA |
| V _{IN} quiescent current (switching) (5) | I _{Q_ACTIVE} | MODE = GND (AAM mode), switching, no load, R _{FB_UP} = 1MΩ, R _{FB_DOWN} = 324kΩ | | 20 | | μA |
| | | MODE = high (FCCM), switching, f _{sw} = 2.2MHz, no load | | 40 | | mA |
| | | MODE = high (FCCM), switching, f _{sw} = 470kHz, no load | | 9.5 | | mA |
| V _{IN} shutdown current | I _{SHDN} | EN = 0V | | 1.7 | 3.5 | μA |
| Feedback (FB) voltage | V _{FB} | V _{IN} = 3.3V to 45V, T _J = 25°C | 807 | 815 | 823 | mV |
| | | V _{IN} = 3.3V to 45V | 799 | 815 | 831 | mV |
| FB current | I _{FB} | V _{FB} = 0.85V | -50 | 0 | +50 | nA |
| Switching frequency | f _{sw} | R _{FREQ} = 62kΩ | 420 | 470 | 520 | kHz |
| | | R _{FREQ} = 12kΩ | 1950 | 2200 | 2450 | kHz |
| Minimum on time (5) | t _{ON_MIN} | | | 100 | | ns |
| Minimum off time (5) | t _{OFF_MIN} | | | 80 | | ns |
| SYNCIN voltage rising threshold | V _{SYNC_RISING} | | 1.8 | | | V |
| SYNCIN voltage falling threshold | V _{SYNC_FALLING} | | | | 0.4 | V |
| SYNCIN clock range | f _{SYNC} | External clock | 350 | | 2200 | kHz |
| SYNCO high voltage | V _{SYNCO_HIGH} | I _{SYNCO} = -1mA | 3.3 | 4.5 | | V |
| SYNCO low voltage | V _{SYNCO_LOW} | I _{SYNCO} = 1mA | | | 0.4 | V |
| SYNCO phase shift | | Tested under SYNCIN | | 180 | | deg |
| High-side (HS) current limit | I _{LIMIT} | Duty cycle = 30%, f _{sw} = 470kHz | 10 | 13 | 16 | A |
| | | Duty cycle=30%, f _{sw} = 2.2MHz | 12.5 | 15.5 | 18.5 | A |
| Low-side (LS) valley current limit | I _{LIMIT_VALLEY} | | 8 | 10 | 12 | A |
| Zero-current detection (ZCD) current | I _{ZCD} | AAM mode | -0.15 | 0.1 | +0.35 | A |
| LS reverse current limit | I _{LIMIT_REVERSE} | FCCM | 2 | 4.5 | 7 | A |

ELECTRICAL CHARACTERISTICS (continued)
V_{IN} = 12V, V_{EN} = 2V, T_J = -40°C to +125°C, typical values are at T_J = 25°C, unless otherwise noted.

| Parameter | Symbol | Condition | Min | Typ | Max | Units |
|--|-----------------------------------|---|--------|--------|--------|------------------|
| Switch leakage current | I _{SW_LKG} | | | 0.01 | 1 | μA |
| High-side MOSFET (HS-FET) on resistance | R _{DSON_HS} | V _{BST} – V _{SW} = 5V | | 48 | 80 | mΩ |
| Low-side MOSFET (LS-FET) on resistance | R _{DSON_LS} | V _{CC} = 5V | | 20 | 40 | mΩ |
| Soft-start current | I _{SS} | V _{SS} = 0V | 4 | 6 | 8.5 | μA |
| EN rising threshold | V _{EN_RISING} | | 0.8 | 1 | 1.2 | V |
| EN falling threshold | V _{EN_FALLING} | | 0.65 | 0.85 | 1.05 | V |
| EN hysteresis voltage | V _{EN_HYS} | | | 190 | | mV |
| MODE rising threshold | V _{MODE_RISING} | | 1.8 | | | V |
| MODE falling threshold | V _{MODE_FALLING} | | | | 0.4 | V |
| Power good (PG) rising threshold (V _{FB} / V _{REF}) | P _G _{RISING} | V _{FB} rising | 92% | 95% | 98% | V _{REF} |
| | | V _{FB} falling | 102% | 105% | 108% | |
| PG falling threshold (V _{FB} / V _{REF}) | P _G _{FALLING} | V _{FB} falling | 90.5% | 93.5% | 96.5% | |
| | | V _{FB} rising | 103.5% | 106.5% | 109.5% | |
| PG output voltage low | V _{PG_LOW} | I _{SINK} = 1mA | | 0.1 | 0.3 | V |
| PG rising delay | t _{PG_R_DELAY} | | | 35 | | μs |
| PG falling delay | t _{PG_F_DELAY} | | | 35 | | μs |
| Thermal shutdown ⁽⁵⁾ | T _{SD} | | | 170 | | °C |
| Thermal shutdown hysteresis ⁽⁵⁾ | T _{SD_HYS} | | | 20 | | °C |

Note:

5) Derived from bench characterization. Not tested in production.

TYPICAL CHARACTERISTICS

$V_{IN} = 12V$, $T_J = -40^{\circ}C$ to $+125^{\circ}C$, unless otherwise noted.

I_Q vs. Temperature

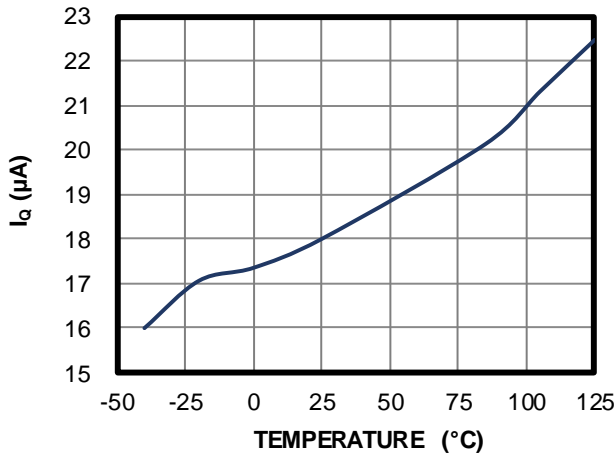

V_{FB} vs. Temperature

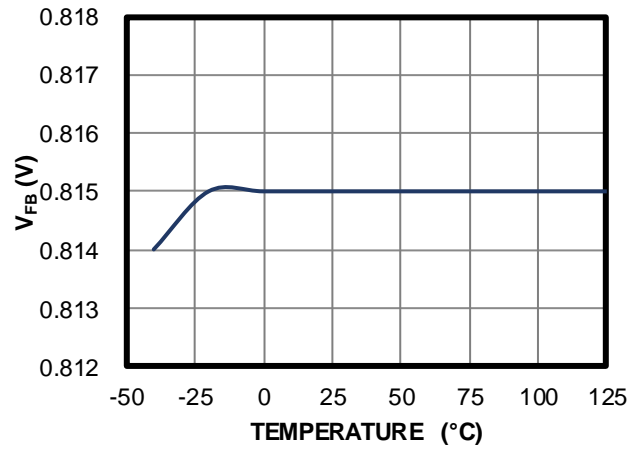

Valley Current Limit vs. Temperature

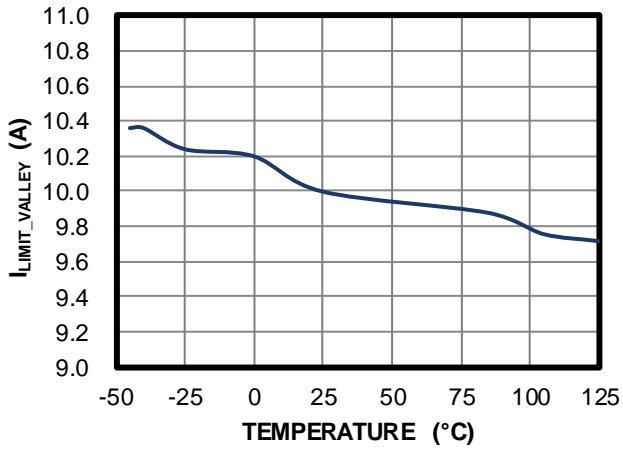

Reverse Current Limit vs. Temperature

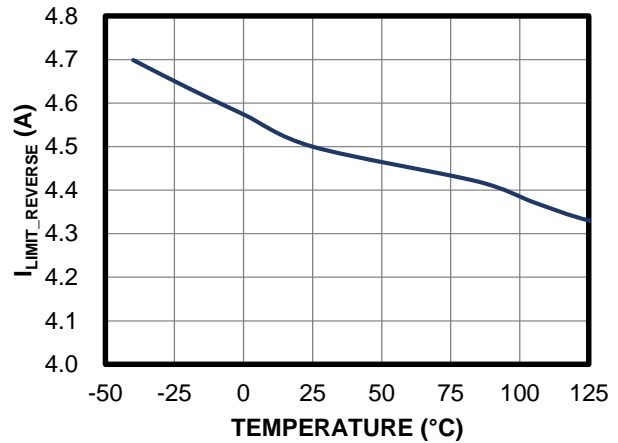

V_{IN} UVLO Threshold vs. Temperature

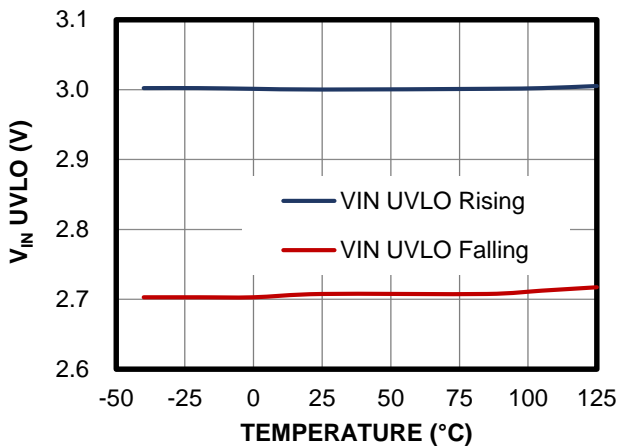

EN UVLO Threshold vs. Temperature

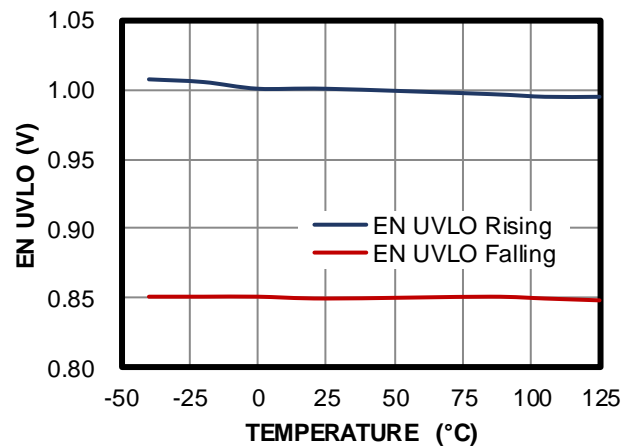

TYPICAL CHARACTERISTICS (continued)
 $V_{IN} = 12V$, $T_J = -40^{\circ}C$ to $+125^{\circ}C$, unless otherwise noted.

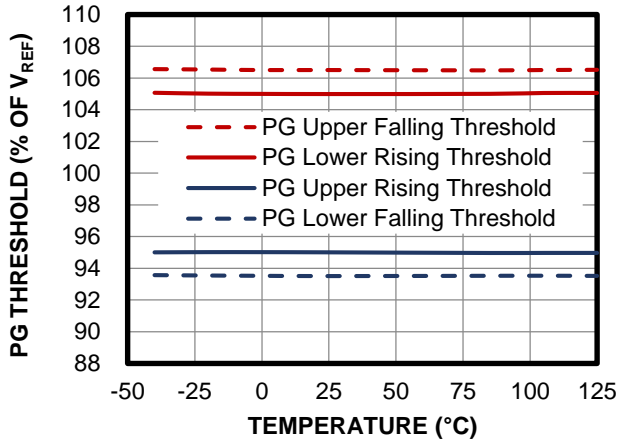
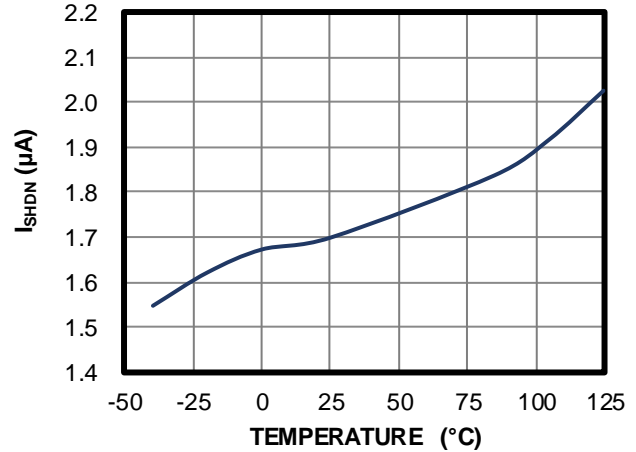
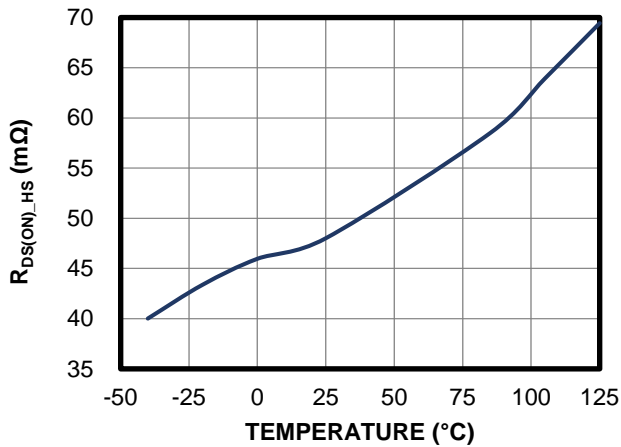
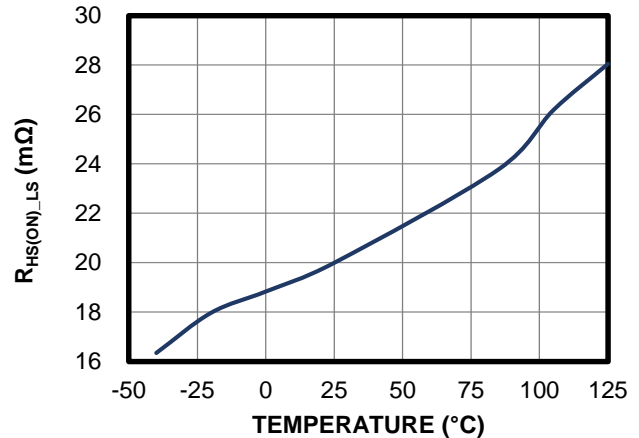
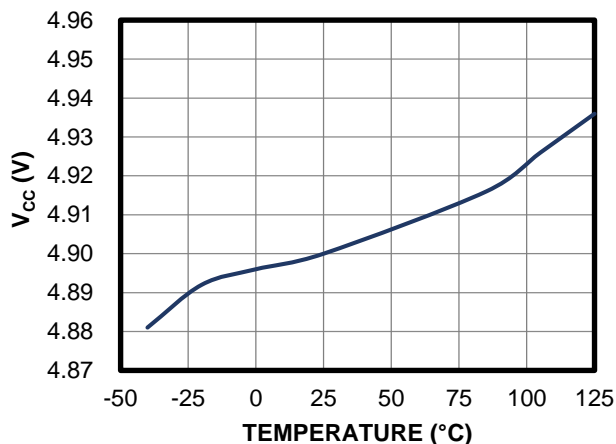
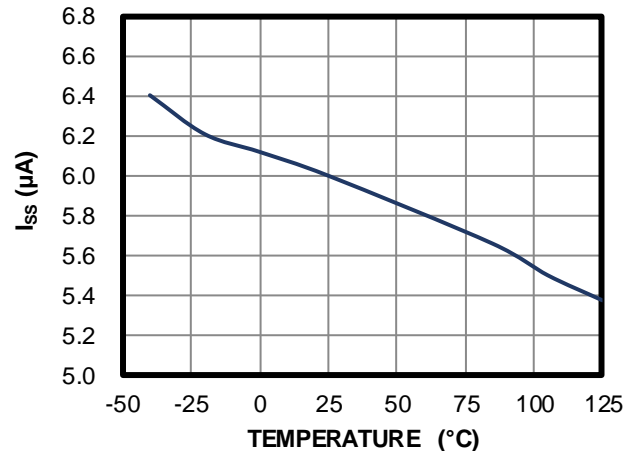
PG Rising/Falling Threshold vs. Temperature

 V_{IN} Shutdown Current vs. Temperature

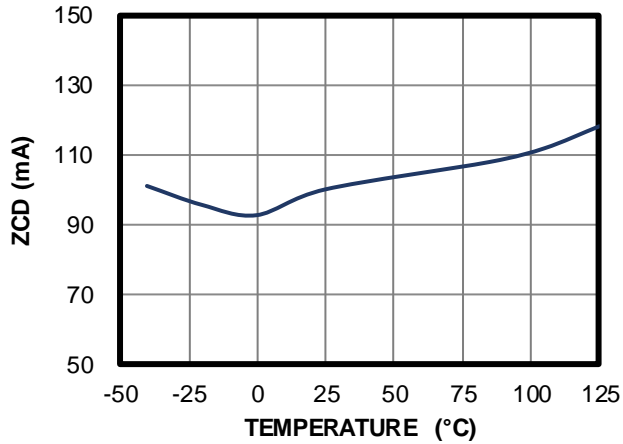
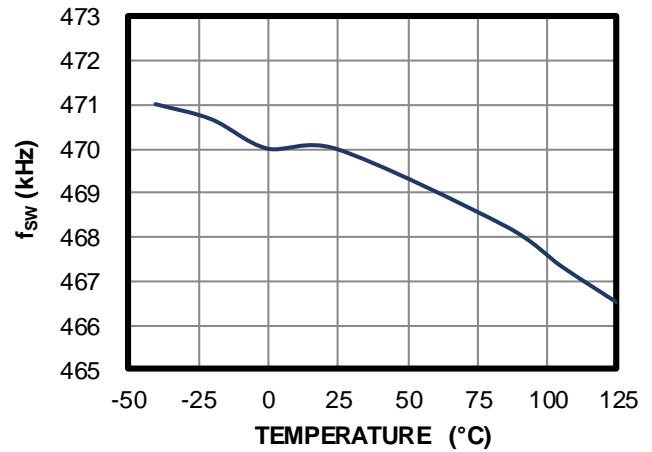
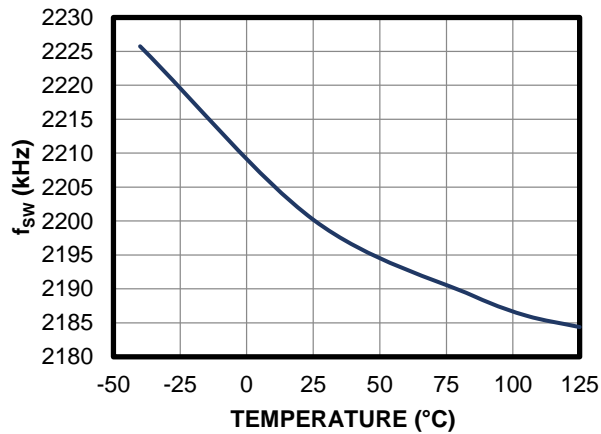
 $R_{DS(ON)_HS}$ vs. Temperature

 $R_{DS(ON)_LS}$ vs. Temperature

 V_{CC} vs. Temperature

Soft-Start Current vs. Temperature

TYPICAL CHARACTERISTICS (continued)
 $V_{IN} = 12V$, $T_J = -40^{\circ}C$ to $+125^{\circ}C$, unless otherwise noted.

ZCD vs. Temperature

 f_{sw} vs. Temperature
 $R_{FREQ} = 62k\Omega$

 f_{sw} vs. Temperature
 $R_{FREQ} = 12k\Omega$

TYPICAL PERFORMANCE CHARACTERISTICS

V_{IN} = 12V, V_{OUT} = 3.3V, L = 4.7μH⁽⁶⁾, f_{sw} = 470kHz, AAM mode, T_A = 25°C, unless otherwise noted.

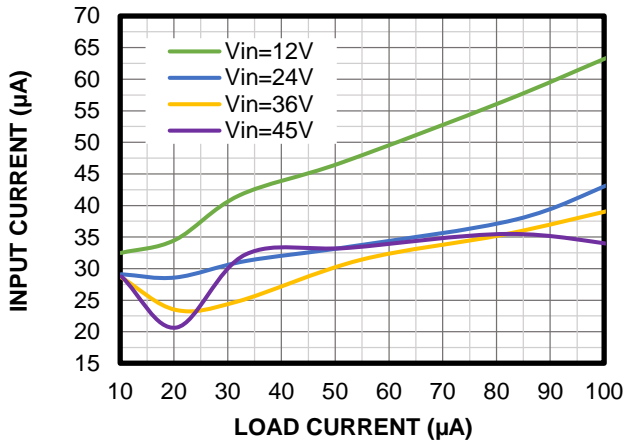
Input Current vs. Load Current

AAM mode, V_{OUT} = 3.3V



Input Current vs. Load Current

AAM mode, V_{OUT} = 5V

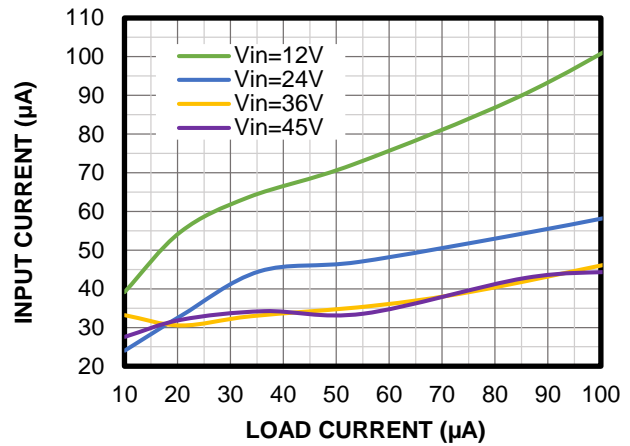

Efficiency vs. Load Current

AAM mode, V_{OUT} = 3.3V

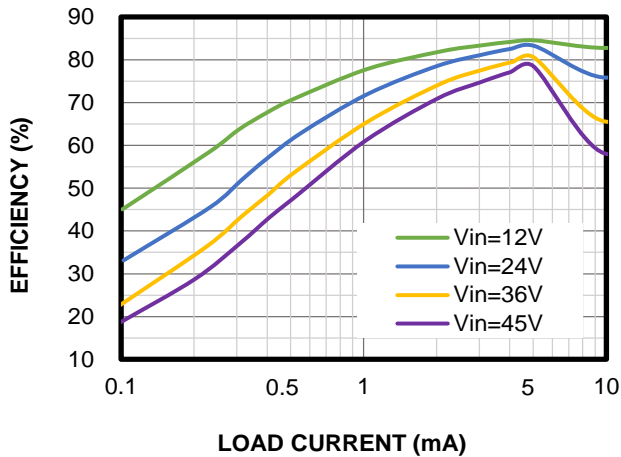

Efficiency vs. Load Current

AAM mode, V_{OUT} = 3.3V

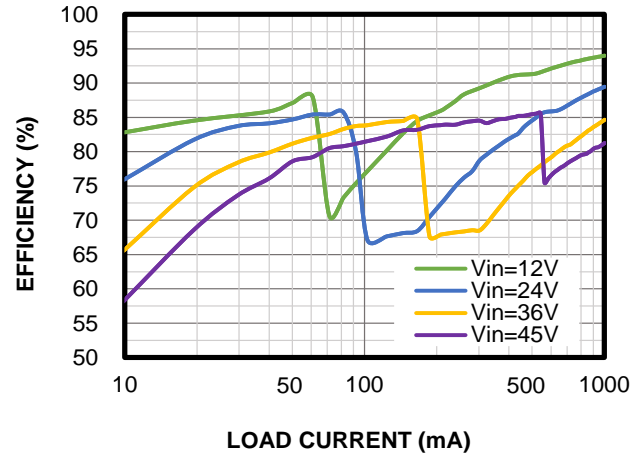

Efficiency vs. Load Current

AAM mode, V_{OUT} = 3.3V

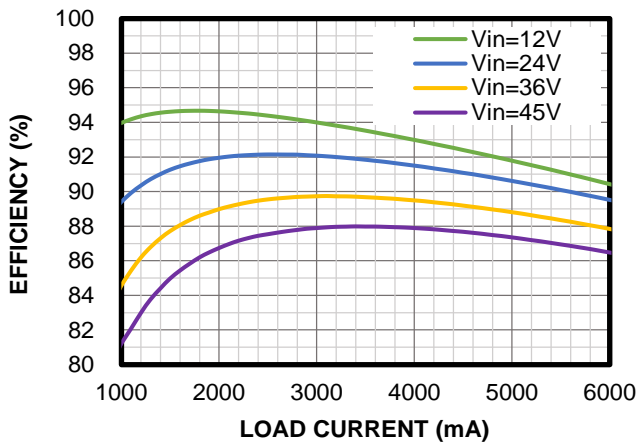

Efficiency vs. Load Current

FCCM, V_{OUT} = 3.3V

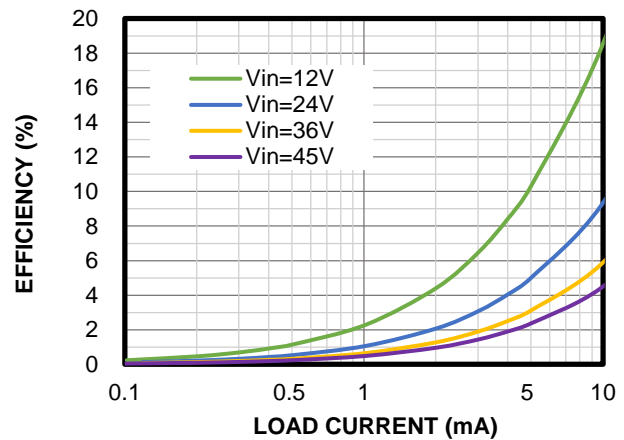

TYPICAL PERFORMANCE CHARACTERISTICS (continued)

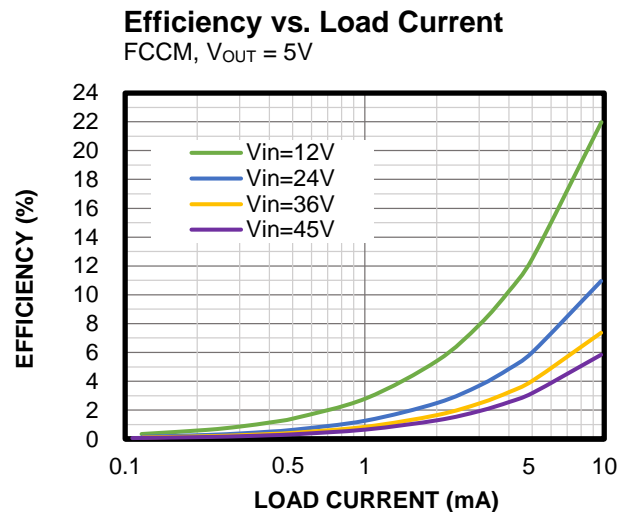
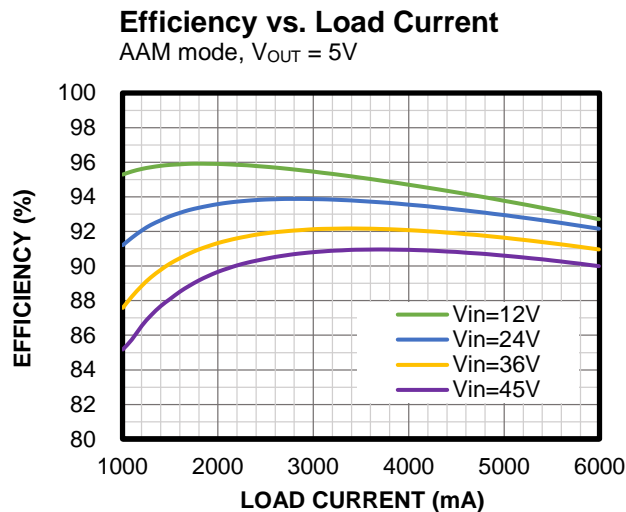
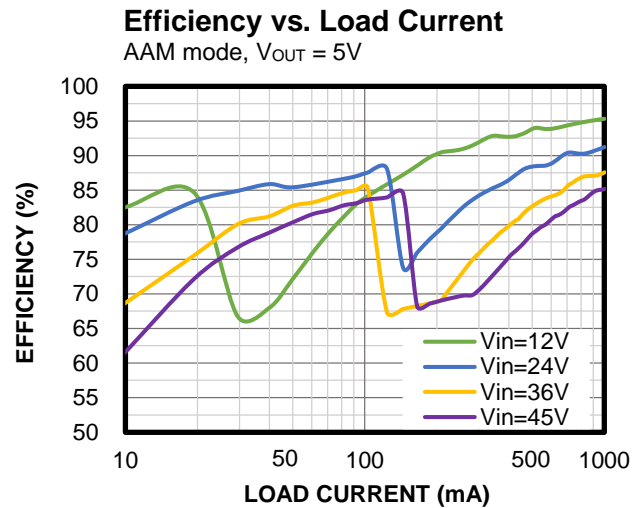
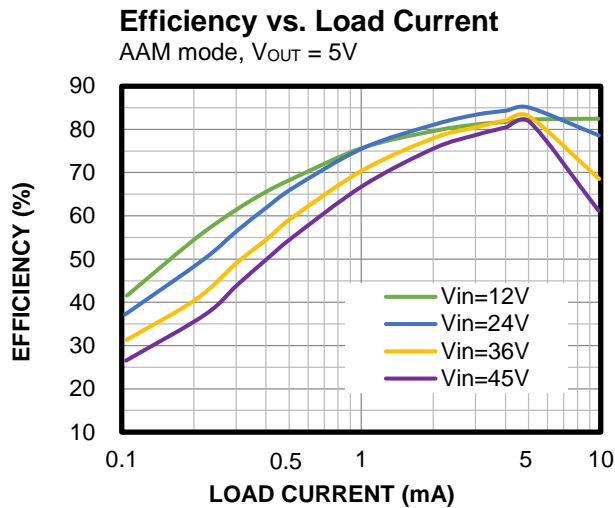
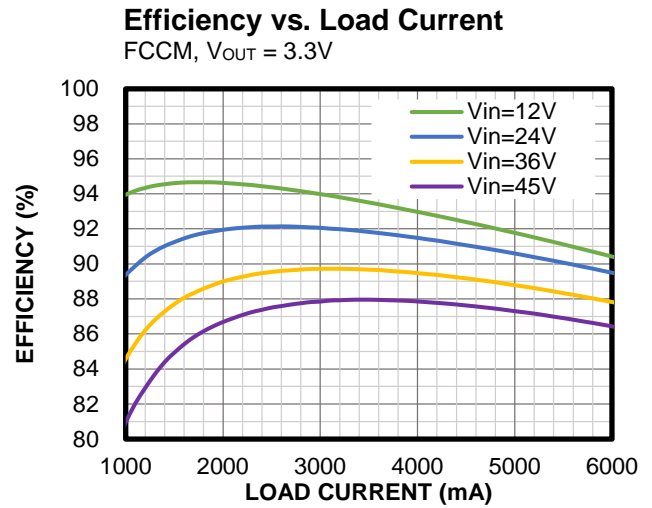
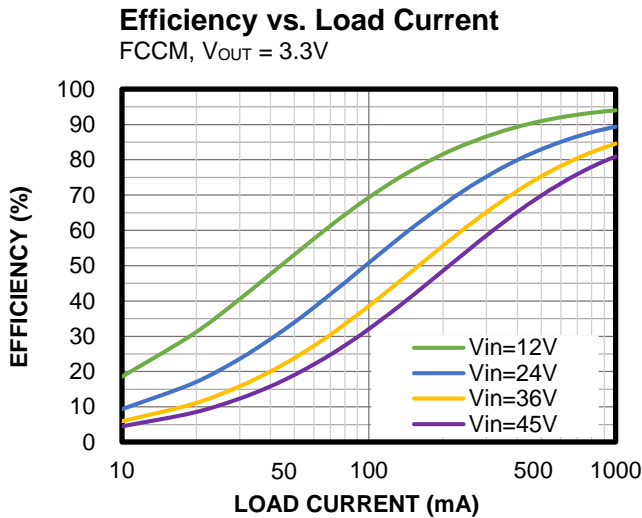
 V_{IN} = 12V, V_{OUT} = 3.3V, L = 4.7μH ⁽⁶⁾, f_{sw} = 470kHz, AAM mode, T_A = 25°C, unless otherwise noted.

TYPICAL PERFORMANCE CHARACTERISTICS (continued)

V_{IN} = 12V, V_{OUT} = 3.3V, L = 4.7μH ⁽⁶⁾, f_{sw} = 470kHz, AAM mode, T_A = 25°C, unless otherwise noted.

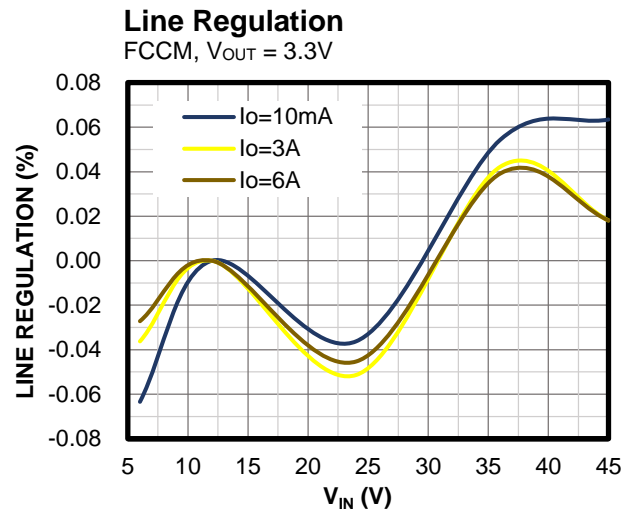
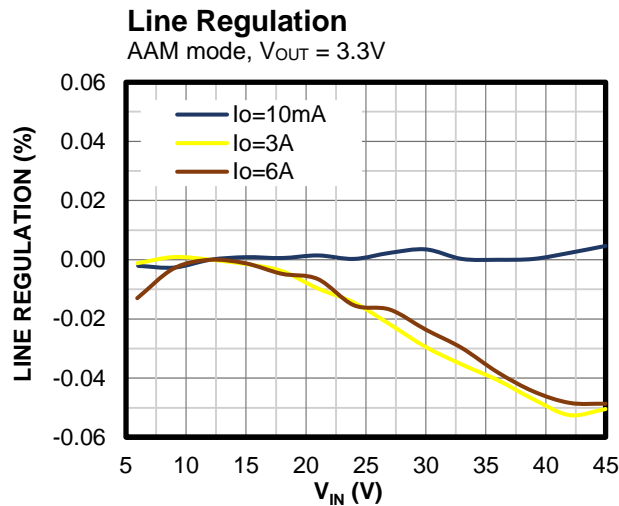
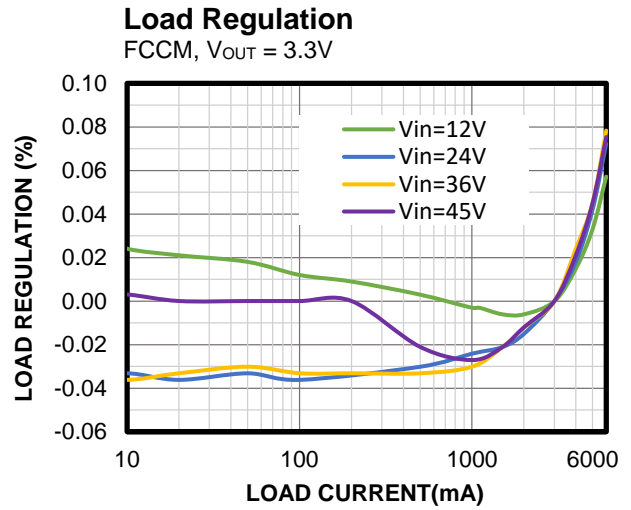
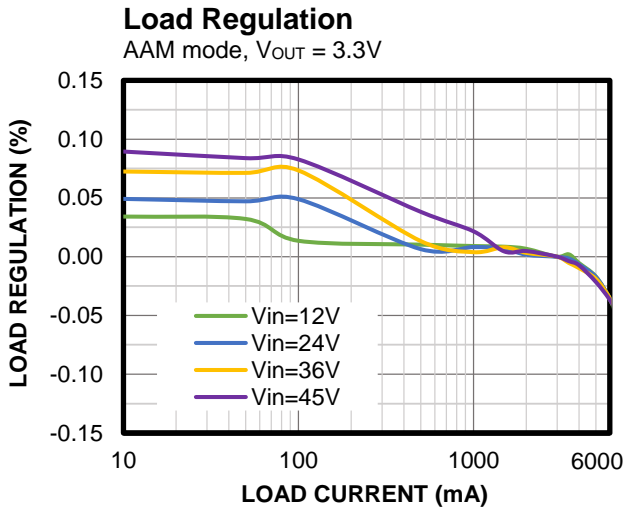
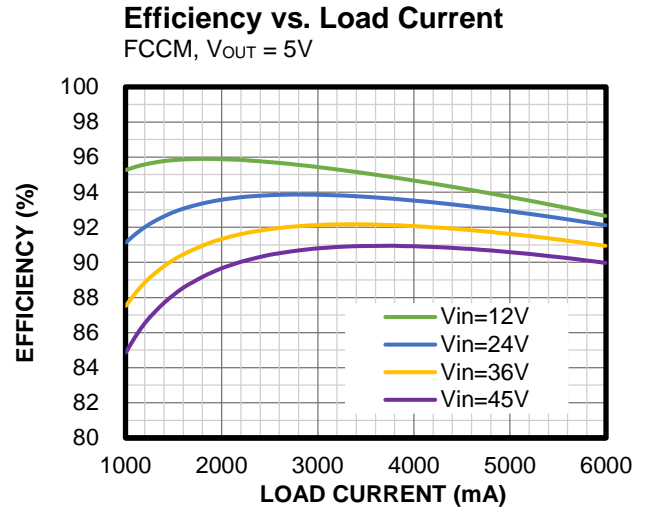
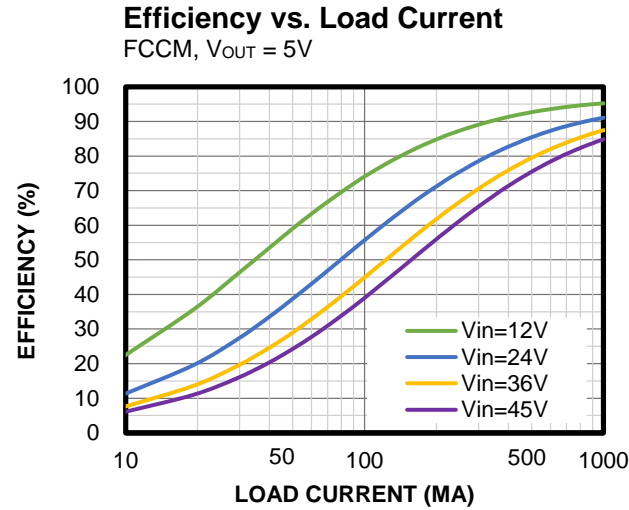

TYPICAL PERFORMANCE CHARACTERISTICS (continued)

V_{IN} = 12V, V_{OUT} = 3.3V, L = 4.7μH⁽⁶⁾, f_{sw} = 470kHz, AAM mode, T_A = 25°C, unless otherwise noted.

Load Regulation

AAM mode, V_{OUT} = 5V

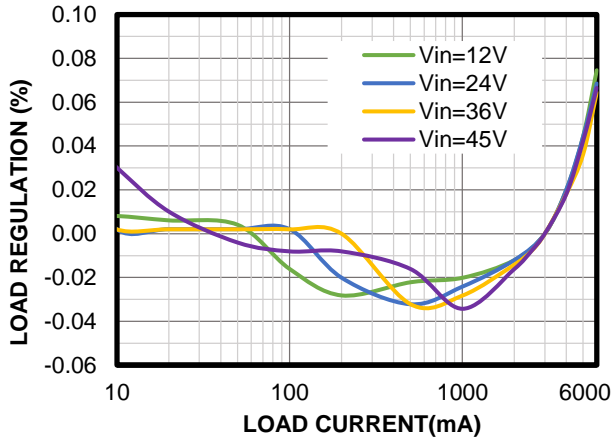

Load Regulation

FCCM, V_{OUT} = 5V

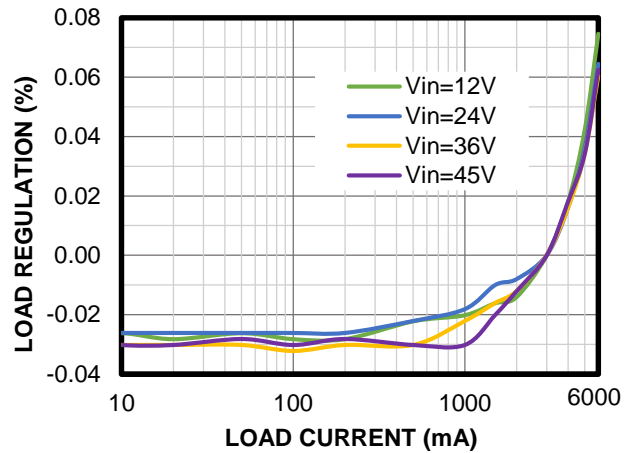

Line Regulation

AAM mode, V_{OUT} = 5V

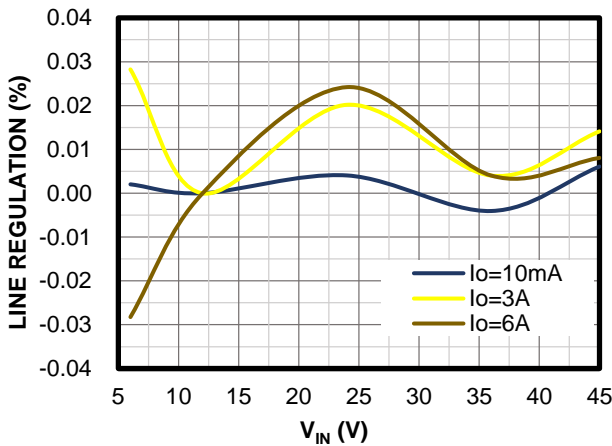

Line Regulation

FCCM, V_{OUT} = 5V

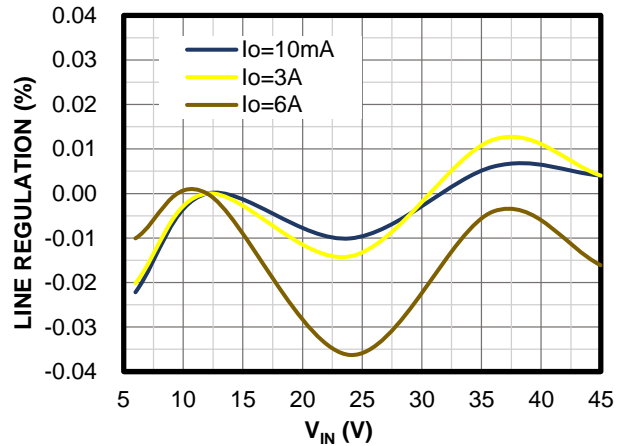

Case Thermal Rise

V_{OUT} = 3.3V

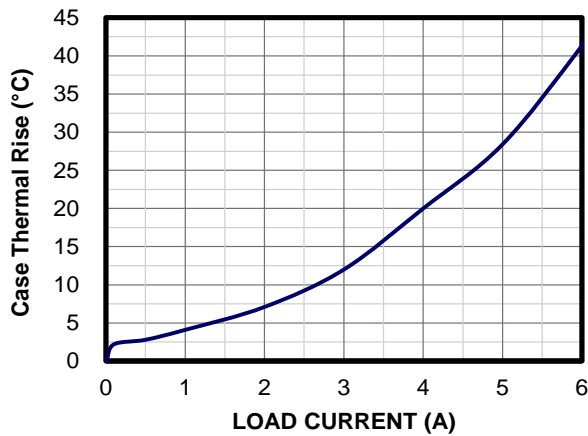

Case Thermal Rise

V_{OUT} = 5V

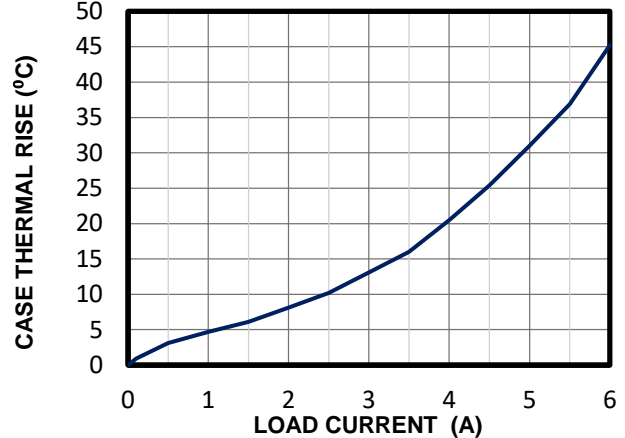

TYPICAL PERFORMANCE CHARACTERISTICS (continued)
 $V_{IN} = 12V$, $V_{OUT} = 3.3V$, $L = 4.7\mu H$ ⁽⁶⁾, $f_{SW} = 470kHz$, AAM mode, $T_A = 25^\circ C$, unless otherwise noted.

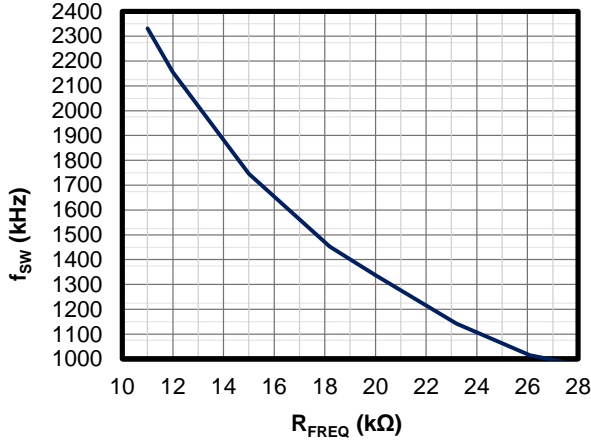
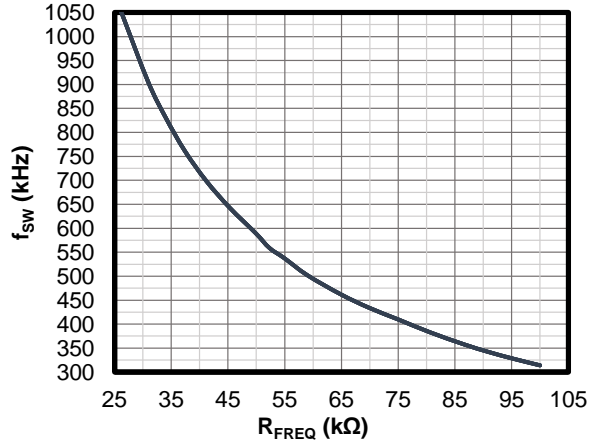
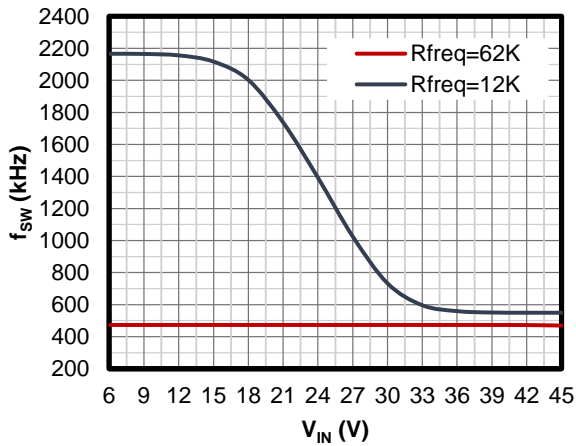
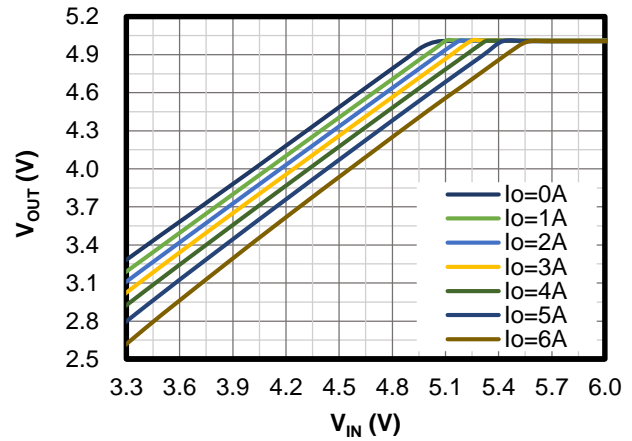
f_{SW} vs. R_{FREQ}
 $f_{SW} = 1000kHz$ to $2300kHz$

f_{SW} vs. R_{FREQ}
 $f_{SW} = 300kHz$ to $1000kHz$

f_{SW} vs. V_{IN}

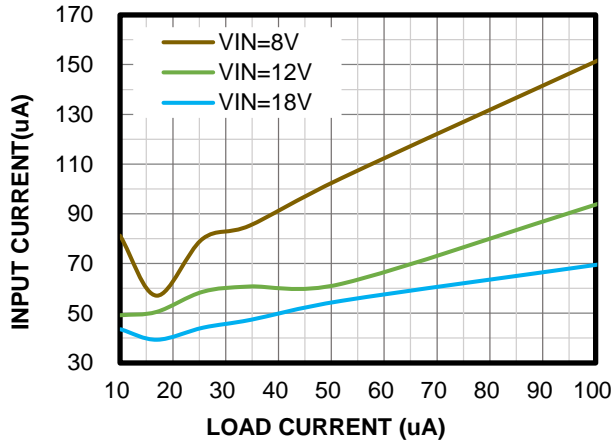
Low-Dropout Mode
 $V_{OUT} = 5V$

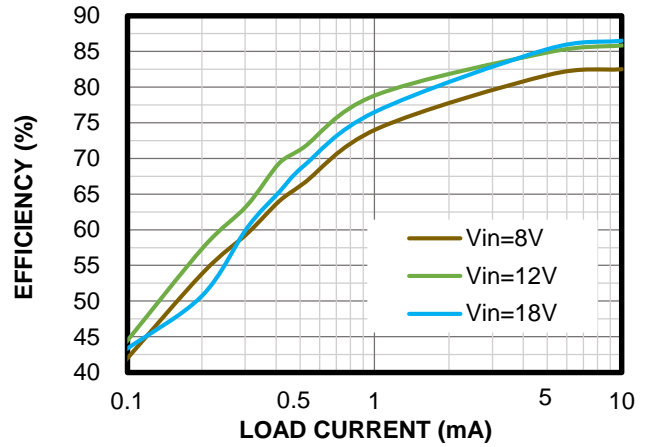
TYPICAL PERFORMANCE CHARACTERISTICS (continued)
 $V_{IN} = 12V$, $V_{OUT} = 5V$, $L = 1\mu H$ ⁽⁷⁾, $f_{SW} = 2.2MHz$, AAM mode, $T_A = 25^\circ C$, unless otherwise noted.

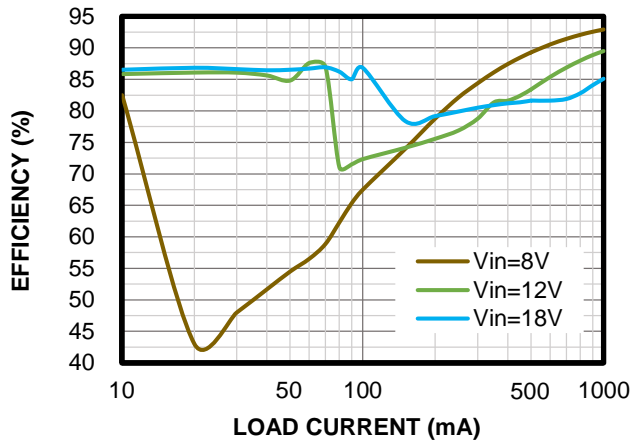
Input Current vs. Load Current

 AAM mode, $V_{OUT} = 5V$

Efficiency vs. Load Current

 AAM mode, $V_{OUT} = 5V$

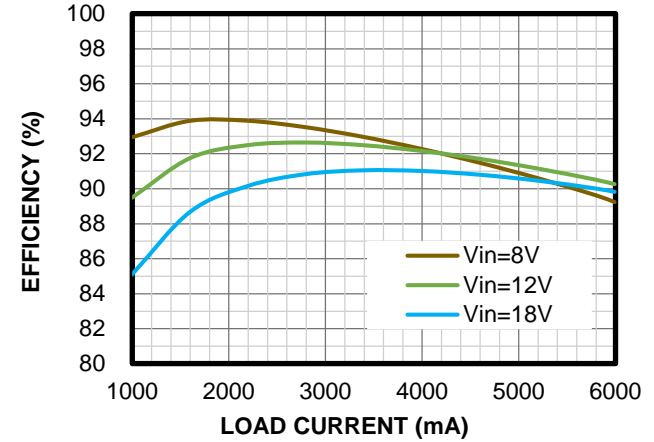
Efficiency vs. Load Current

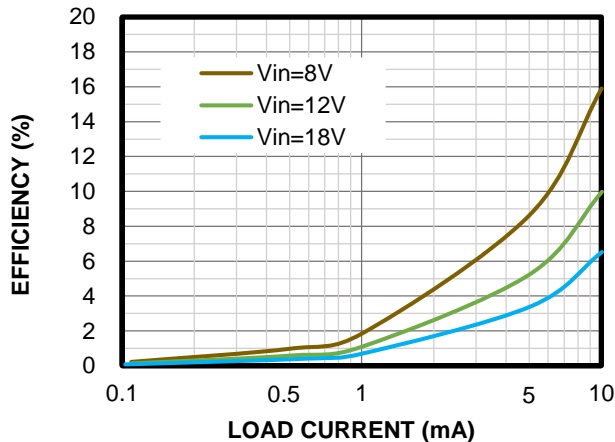
 AAM mode, $V_{OUT} = 5V$

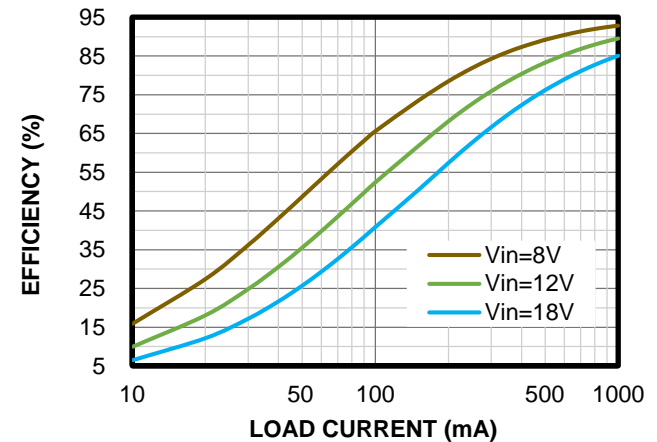
Efficiency vs. Load Current

 AAM mode, $V_{OUT} = 5V$

Efficiency vs. Load Current

 FCCM, $V_{OUT} = 5V$

Efficiency vs. Load Current

 FCCM, $V_{OUT} = 5V$

TYPICAL PERFORMANCE CHARACTERISTICS (continued)

 V_{IN} = 12V, V_{OUT} = 5V, L = 1μH⁽⁷⁾, f_{SW} = 2.2MHz, AAM mode, T_A = 25°C, unless otherwise noted.

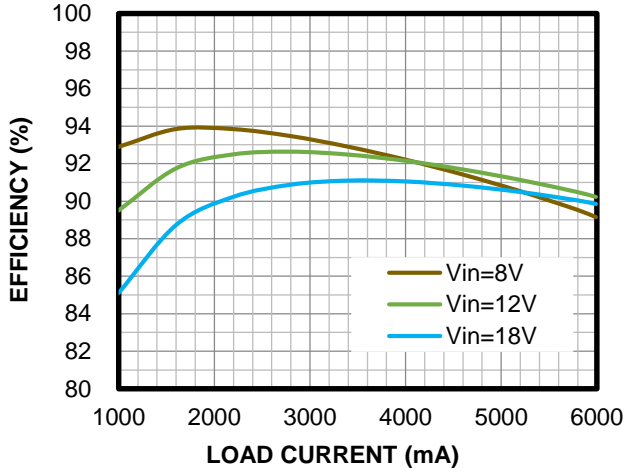
Efficiency vs. Load Current

 FCCM, V_{OUT} = 5V

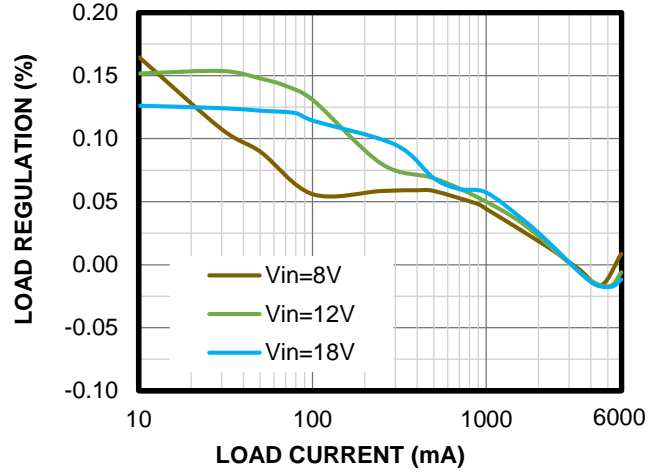
Load Regulation

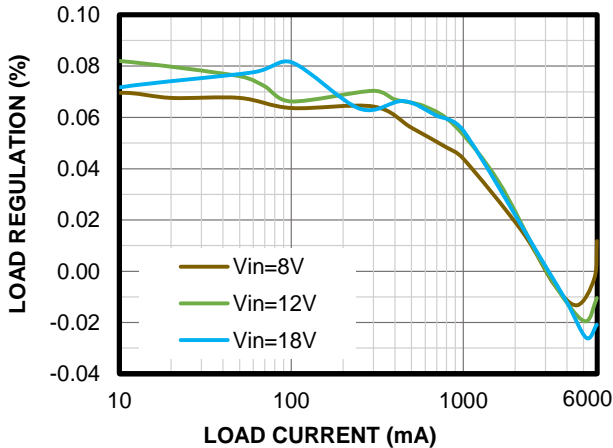
 AAM mode, V_{OUT} = 5V

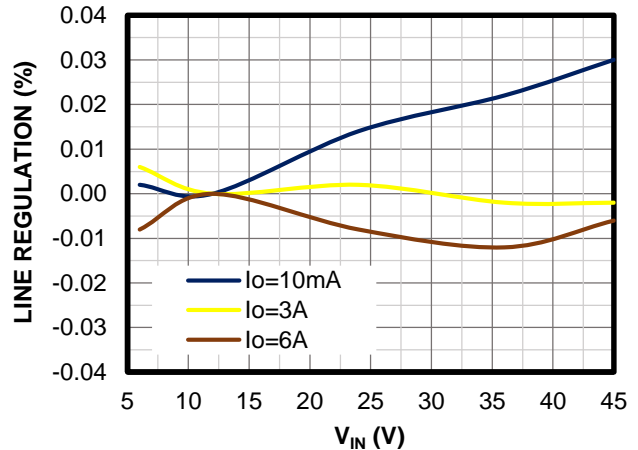
Load Regulation

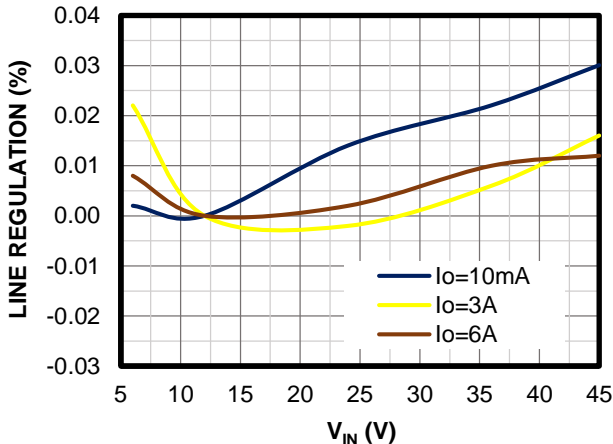
 FCCM, V_{OUT} = 5V

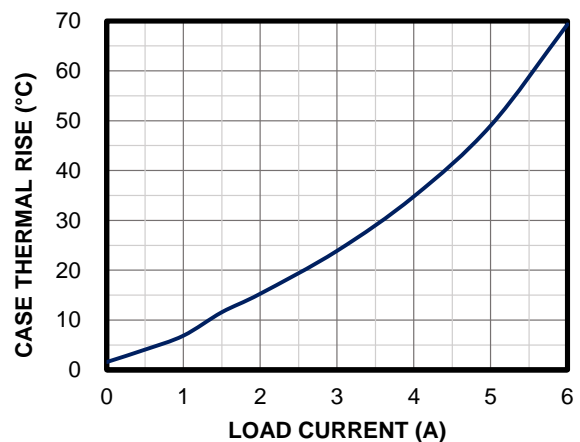
Line Regulation

 AAM mode, V_{OUT} = 5V

Line Regulation

 FCCM, V_{OUT} = 5V

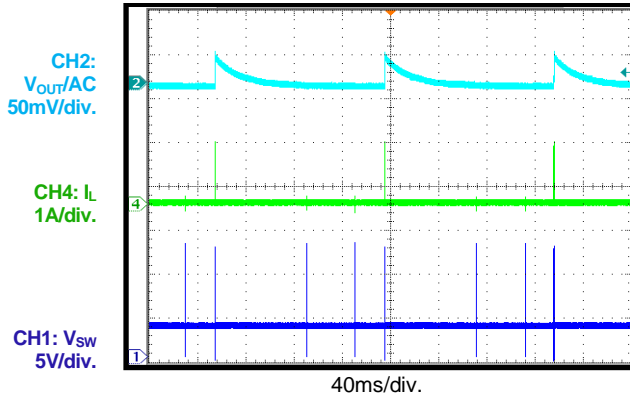
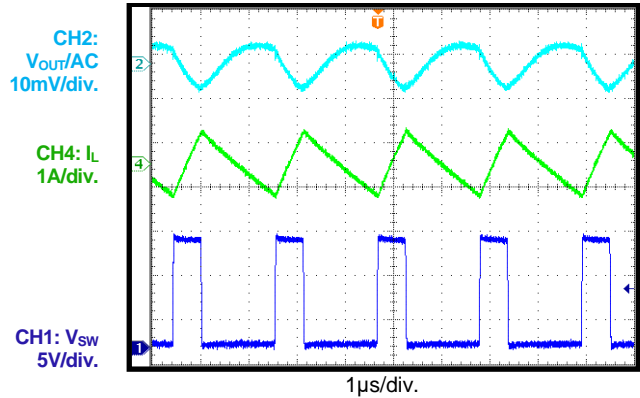
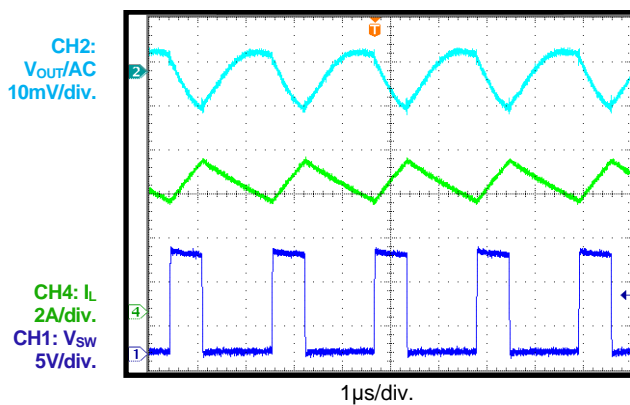
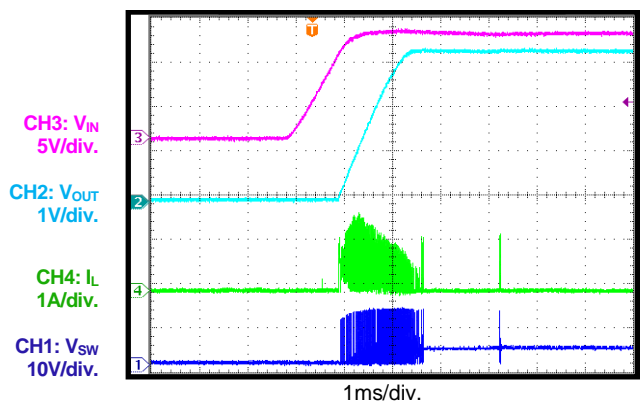
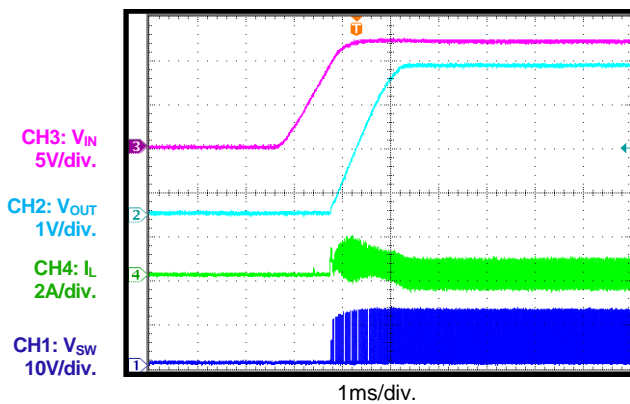
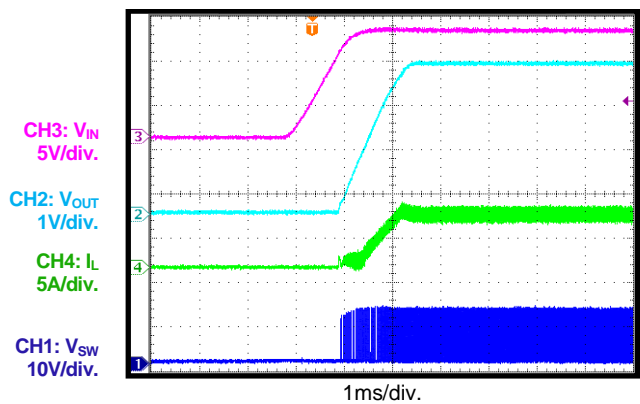
Case Thermal Rise

 V_{OUT} = 5V

TYPICAL PERFORMANCE CHARACTERISTICS (continued)
 $V_{IN} = 12V$, $V_{OUT} = 3.3V$, $L = 4.7\mu H$ ⁽⁶⁾, $f_{sw} = 470kHz$, AAM mode, $T_A = 25^{\circ}C$, unless otherwise noted.

Steady State
 $I_{OUT} = 0A$, AAM mode

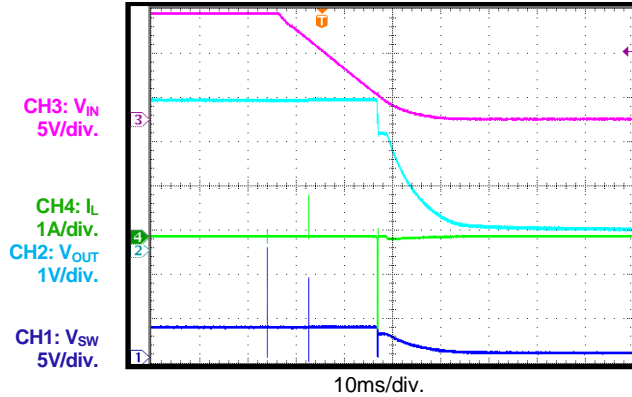
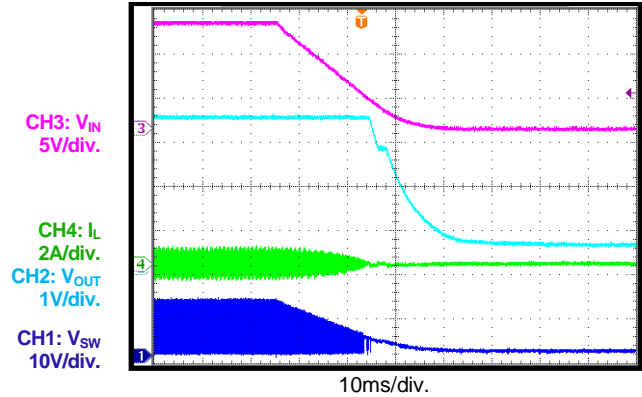
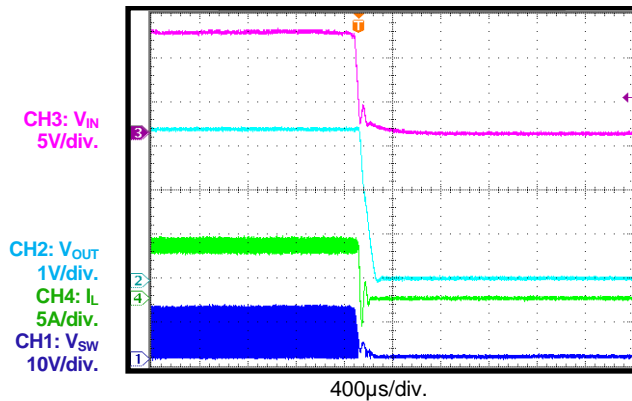
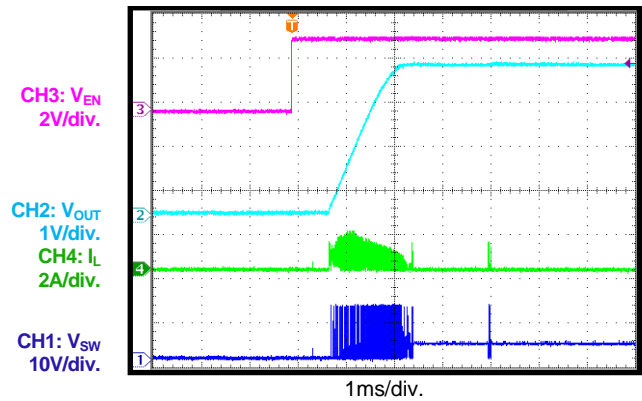
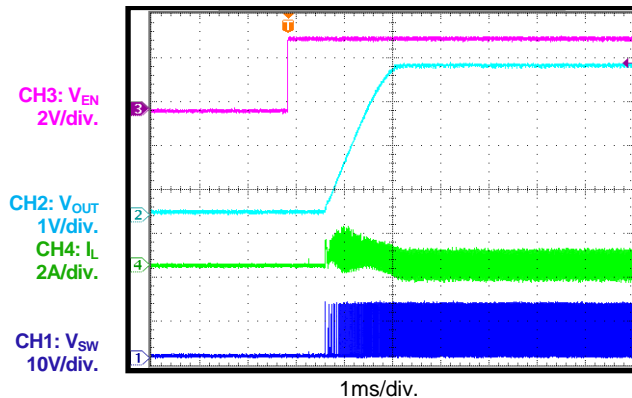
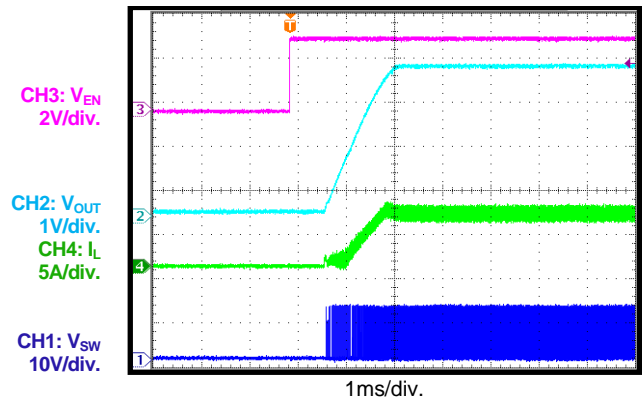
Steady State
 $I_{OUT} = 0A$, FCCM

Steady State
 $I_{OUT} = 6A$

Start-Up through VIN
 $I_{OUT} = 0A$, AAM mode

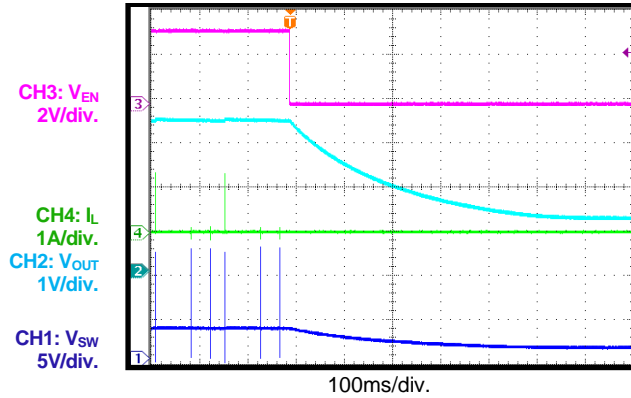
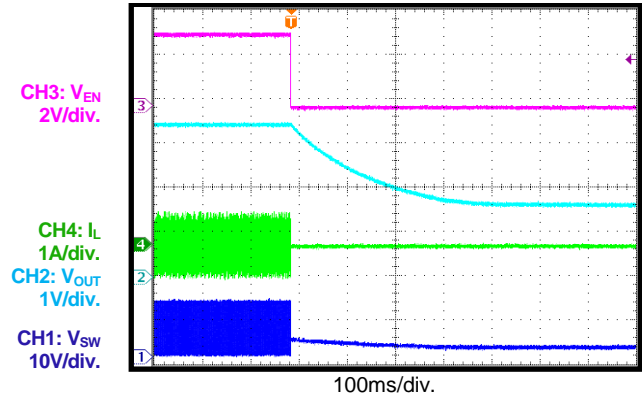
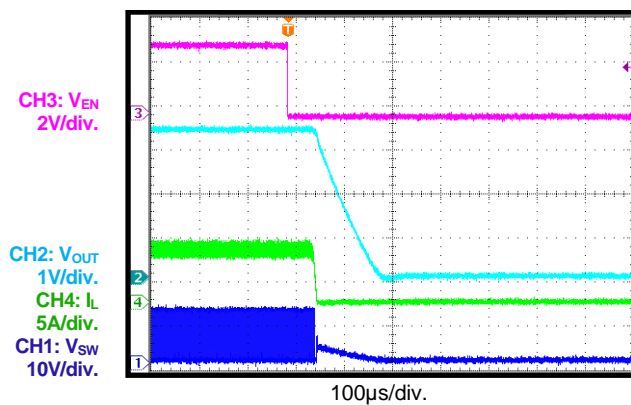
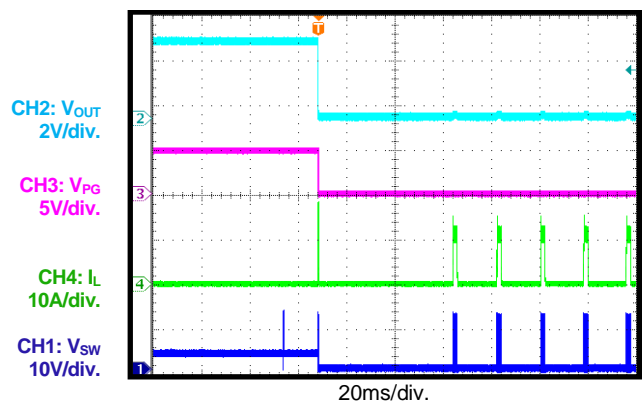
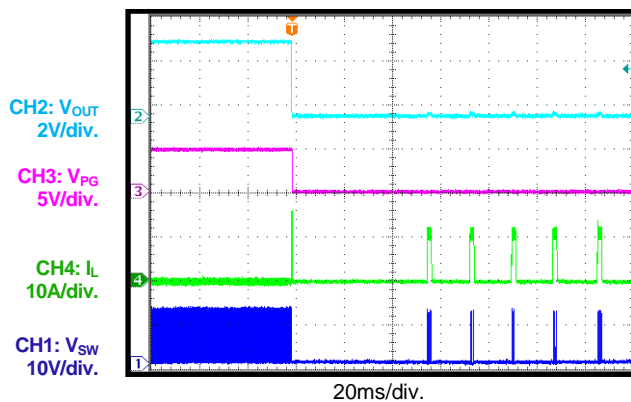
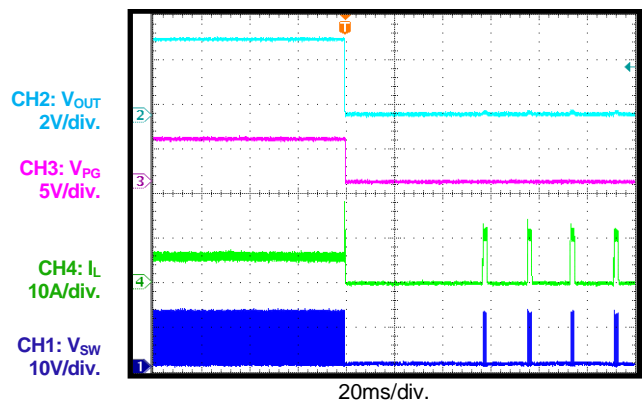
Start-Up through VIN
 $I_{OUT} = 0A$, FCCM

Start-Up through VIN
 $I_{OUT} = 6A$

TYPICAL PERFORMANCE CHARACTERISTICS (continued)
 $V_{IN} = 12V$, $V_{OUT} = 3.3V$, $L = 4.7\mu H$ ⁽⁶⁾, $f_{SW} = 470kHz$, AAM mode, $T_A = 25^\circ C$, unless otherwise noted.

Shutdown through VIN
 $I_{OUT} = 0A$, AAM mode

Shutdown through VIN
 $I_{OUT} = 0A$, FCCM

Shutdown through VIN
 $I_{OUT} = 6A$

Start-Up through EN
 $I_{OUT} = 0A$, AAM mode

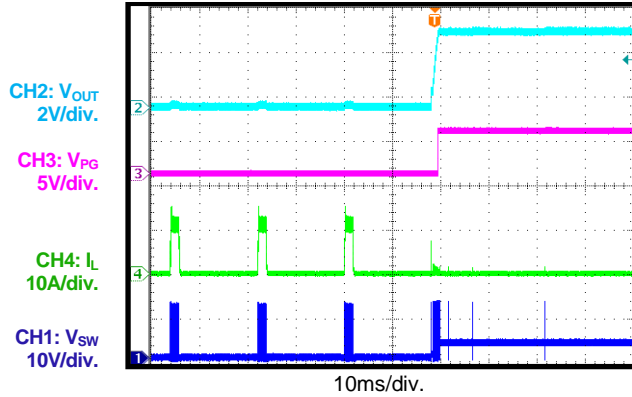
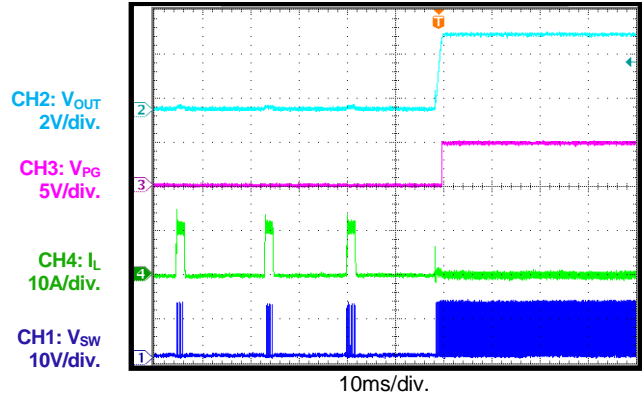
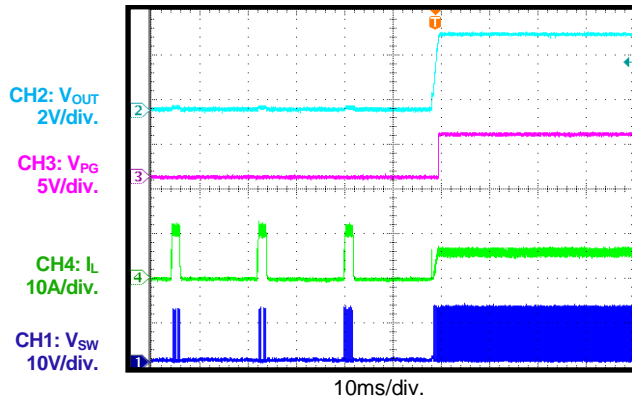
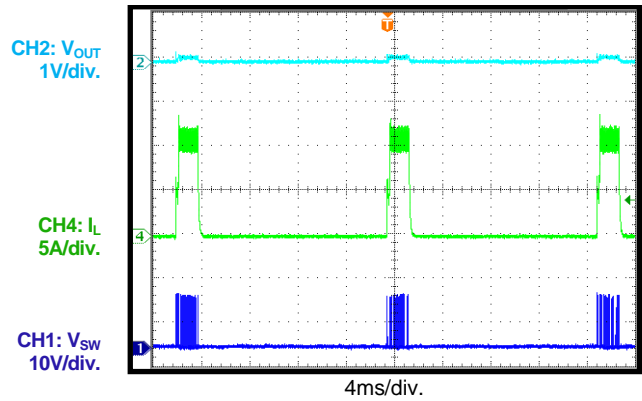
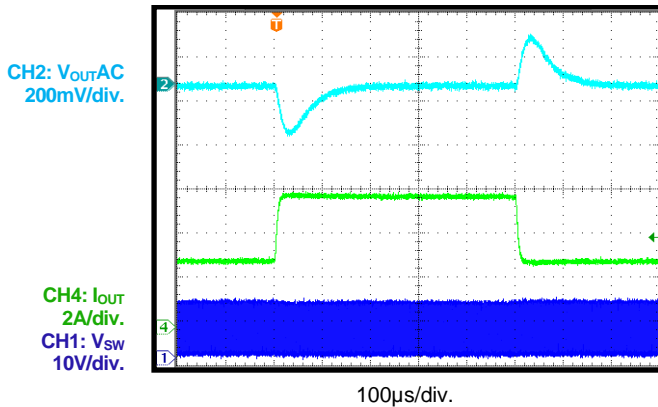
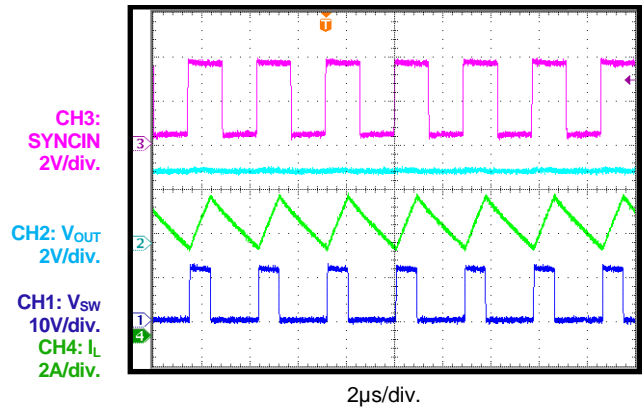
Start-Up through EN
 $I_{OUT} = 0A$, FCCM

Start-Up through EN
 $I_{OUT} = 6A$

TYPICAL PERFORMANCE CHARACTERISTICS (continued)
 $V_{IN} = 12V$, $V_{OUT} = 3.3V$, $L = 4.7\mu H$ ⁽⁶⁾, $f_{SW} = 470kHz$, AAM mode, $T_A = 25^\circ C$, unless otherwise noted.

Shutdown through EN
 $I_{OUT} = 0A$, AAM mode

Shutdown through EN
 $I_{OUT} = 0A$, FCCM

Shutdown through EN
 $I_{OUT} = 6A$

SCP Entry
 $I_{OUT} = 0A$, AAM mode

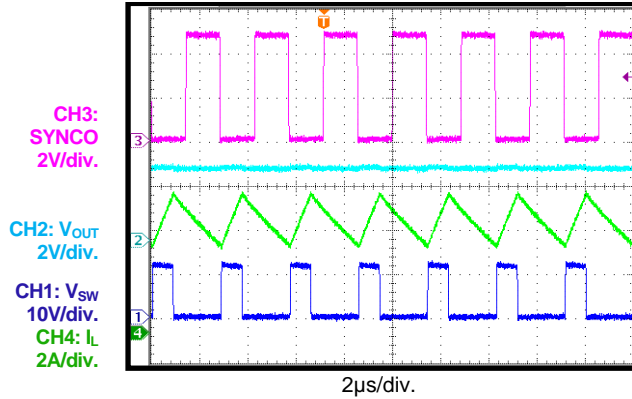
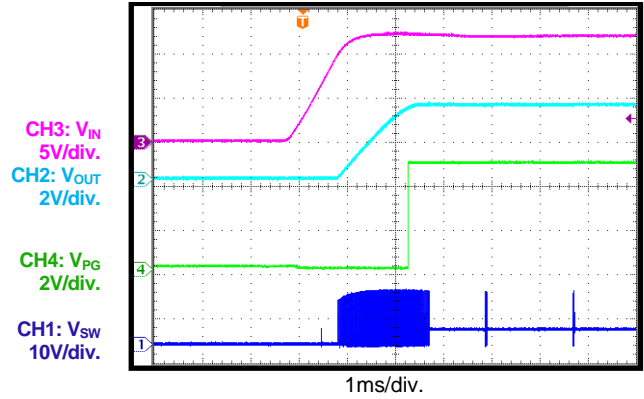
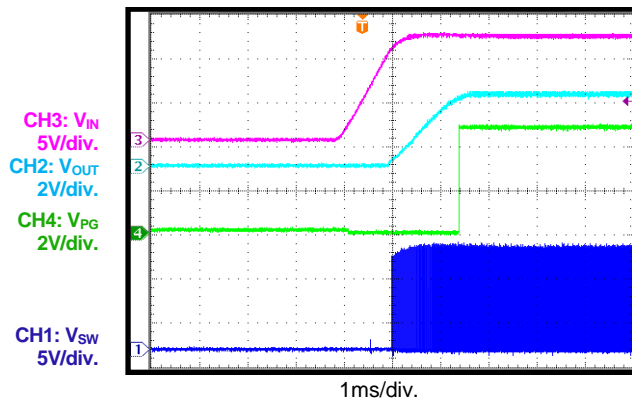
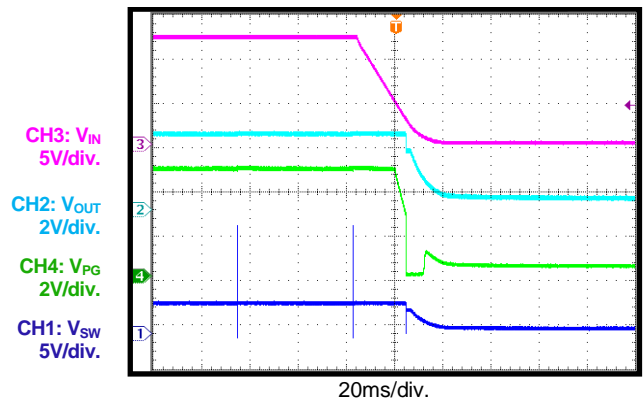
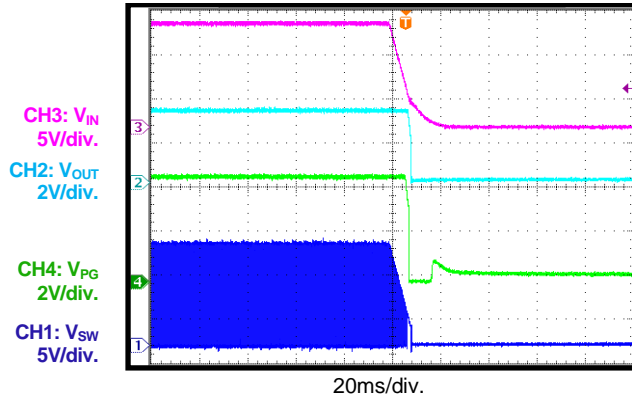
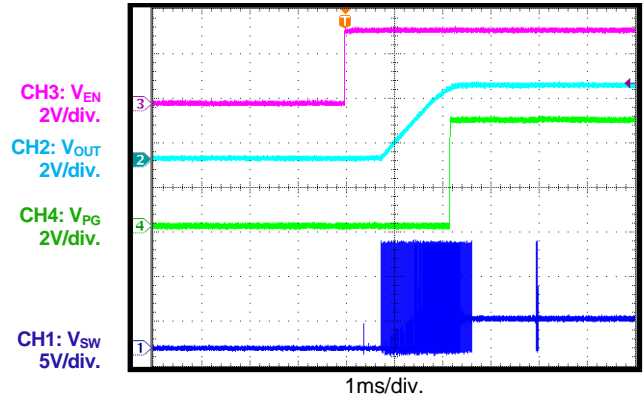
SCP Entry
 $I_{OUT} = 0A$, FCCM

SCP Entry
 $I_{OUT} = 6A$

TYPICAL PERFORMANCE CHARACTERISTICS (continued)
 $V_{IN} = 12V$, $V_{OUT} = 3.3V$, $L = 4.7\mu H$ ⁽⁶⁾, $f_{SW} = 470kHz$, AAM mode, $T_A = 25^\circ C$, unless otherwise noted.

SCP Recovery
 $I_{OUT} = 0A$, AAM mode

SCP Recovery
 $I_{OUT} = 0A$, FCCM

SCP Recovery
 $I_{OUT} = 6A$

SCP Steady State

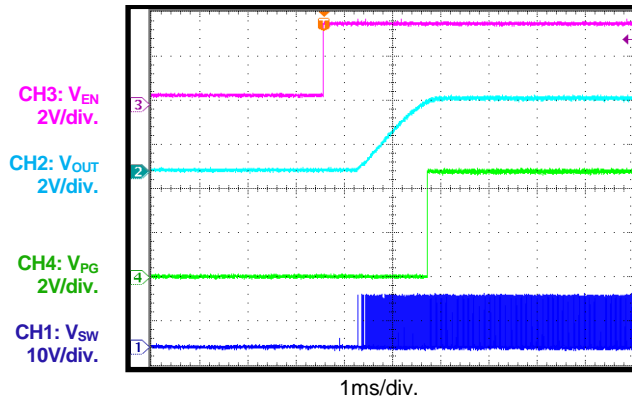
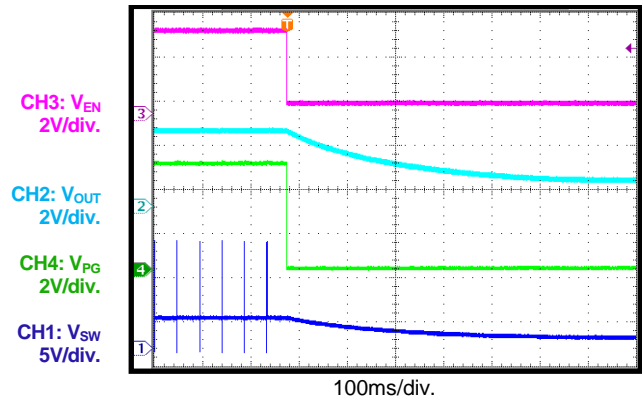
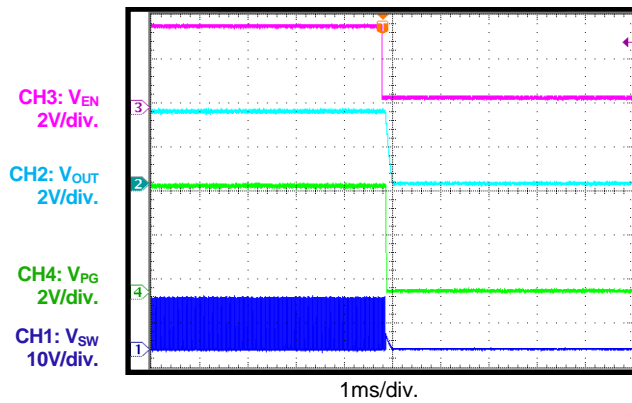
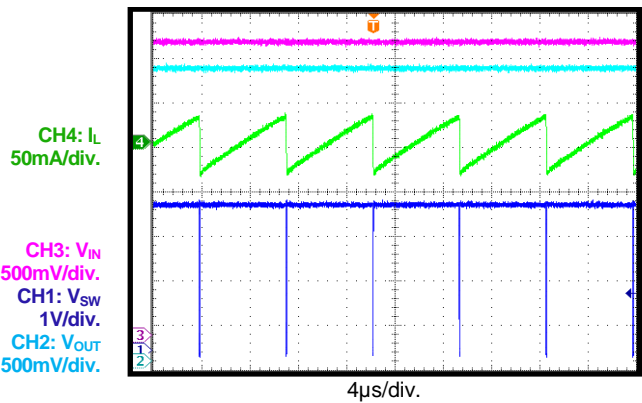
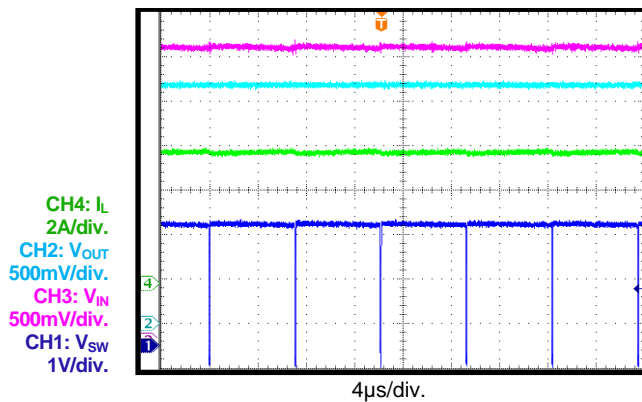
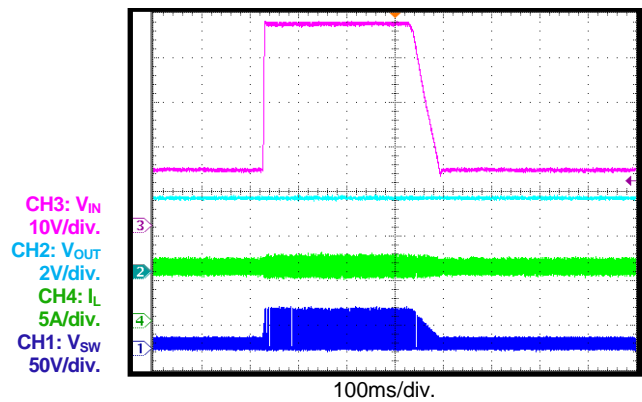
Load Transient
 $I_{OUT} = 3A$ to $6A$, $1.6A/\mu s$

SYNC Operation
 $I_{OUT} = 6A$, SYNC frequency = 350kHz

TYPICAL PERFORMANCE CHARACTERISTICS (continued)
 $V_{IN} = 12V$, $V_{OUT} = 3.3V$, $L = 4.7\mu H$ ⁽⁶⁾, $f_{SW} = 470kHz$, AAM mode, $T_A = 25^\circ C$, unless otherwise noted.

SYNCO Operation
 $I_{OUT} = 6A$, SYNC frequency = 350kHz

PG Start-Up through VIN
 $I_{OUT} = 0A$

PG Start-Up through VIN
 $I_{OUT} = 6A$

PG Shutdown through VIN
 $I_{OUT} = 0A$

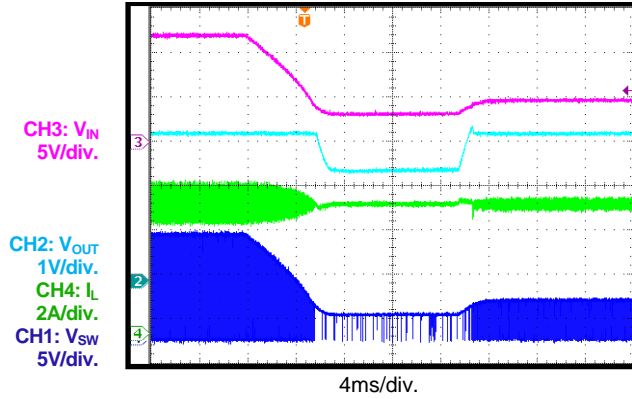
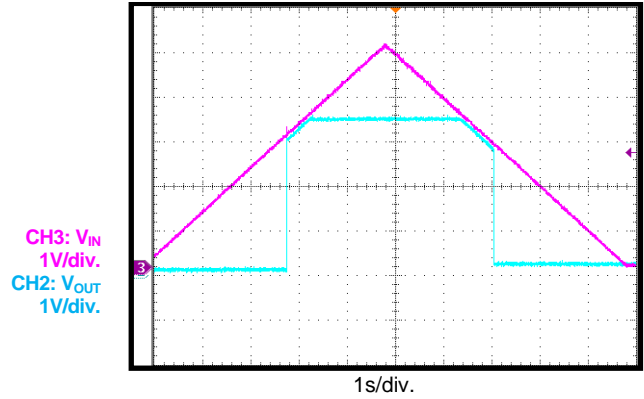
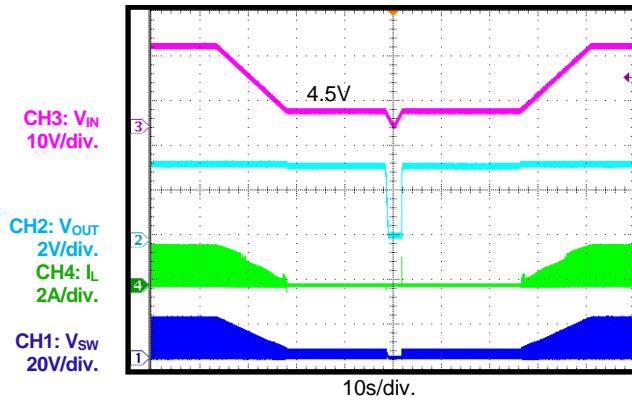
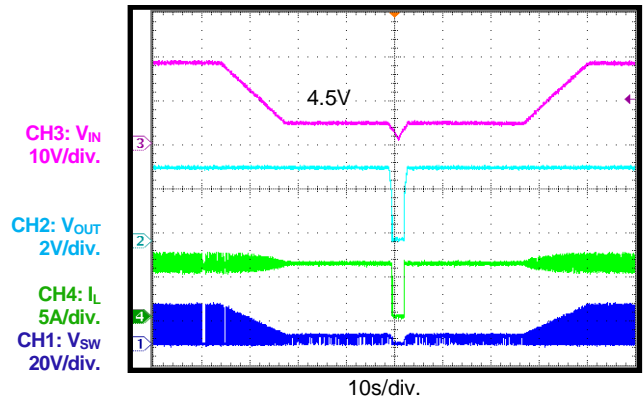
PG Shutdown through VIN
 $I_{OUT} = 6A$

PG Start-Up through EN
 $I_{OUT} = 0A$

TYPICAL PERFORMANCE CHARACTERISTICS (continued)
 $V_{IN} = 12V$, $V_{OUT} = 3.3V$, $L = 4.7\mu H$ ⁽⁶⁾, $f_{SW} = 470kHz$, AAM mode, $T_A = 25^\circ C$, unless otherwise noted.

PG Start-Up through EN
 $I_{OUT} = 6A$

PG Shutdown through EN
 $I_{OUT} = 0A$

PG Shutdown through EN
 $I_{OUT} = 6A$

Low-Dropout Mode
 $V_{IN} = 3.3V$, V_{OUT} set to 3.3V, $I_{OUT} = 0A$

Low-Dropout Mode
 $V_{IN} = 3.3V$, V_{OUT} set to 3.3V, $I_{OUT} = 6A$

Load Dump
 $V_{IN} = 12V$ to 36V, $I_{OUT} = 6A$

TYPICAL PERFORMANCE CHARACTERISTICS (continued)
 $V_{IN} = 12V$, $V_{OUT} = 3.3V$, $L = 4.7\mu H$ ⁽⁶⁾, $f_{SW} = 470kHz$, AAM mode, $T_A = 25^\circ C$, unless otherwise noted.

Cold Crank
 $V_{IN} = 12V$ to $3.3V$ to $5V$, $I_{OUT} = 6A$

 V_{IN} Ramping Up and Down
 $I_{OUT} = 0.1A$

 V_{IN} Ramping Down and Up
 $I_{OUT} = 1mA$

 V_{IN} Ramping Down and Up
 $I_{OUT} = 6A$

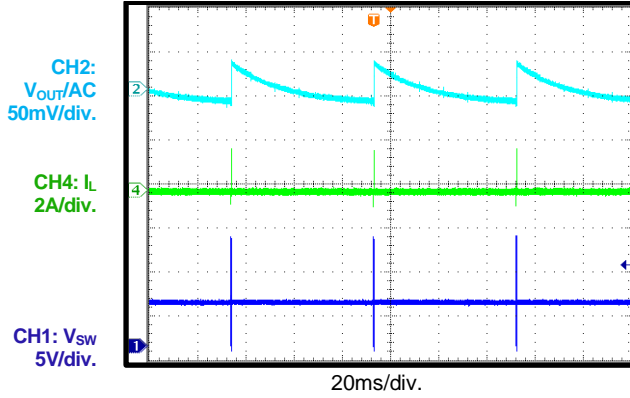
TYPICAL PERFORMANCE CHARACTERISTICS (continued)

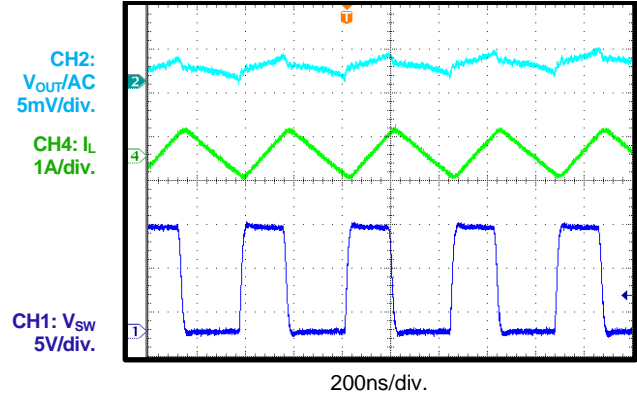
 V_{IN} = 12V, V_{OUT} = 5V, L = 1μH⁽⁷⁾, f_{sw} = 2.2MHz, AAM mode, T_A = 25°C, unless otherwise noted.

Steady State

 I_{OUT} = 0A, AAM mode

Steady State

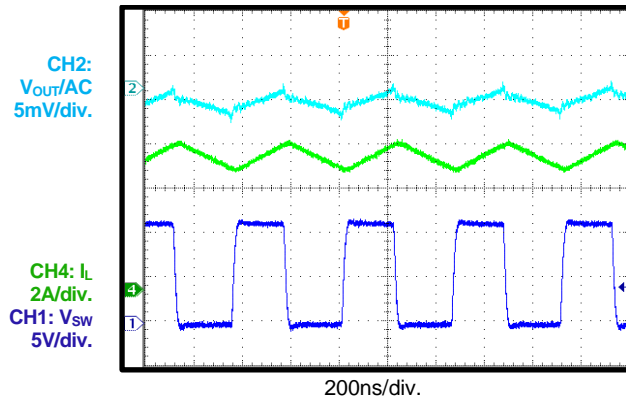
 I_{OUT} = 0A, FCCM

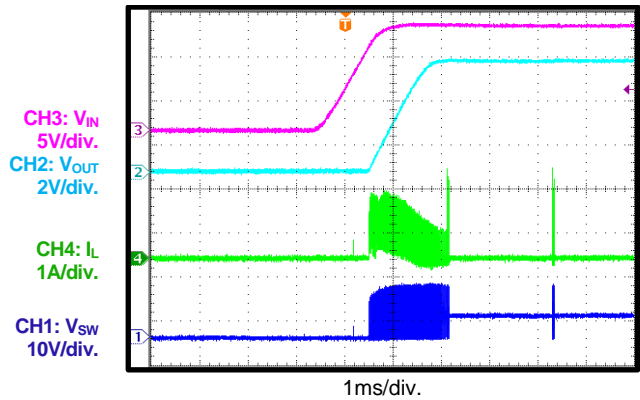
Steady State

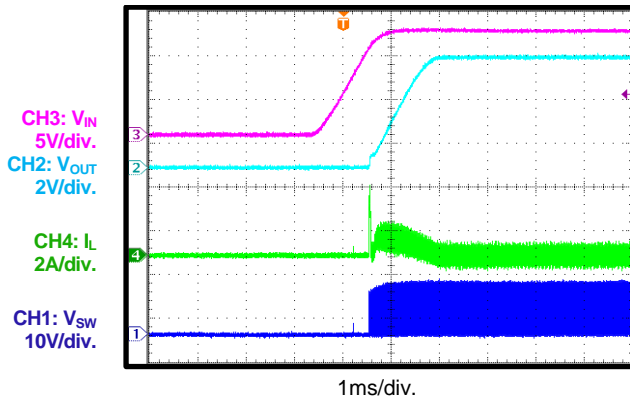
 I_{OUT} = 6A

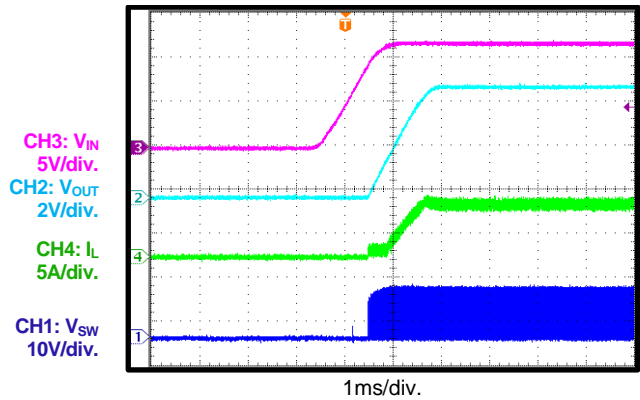
Start-Up through VIN

 I_{OUT} = 0A, AAM mode

Start-Up through VIN

 I_{OUT} = 0A, FCCM

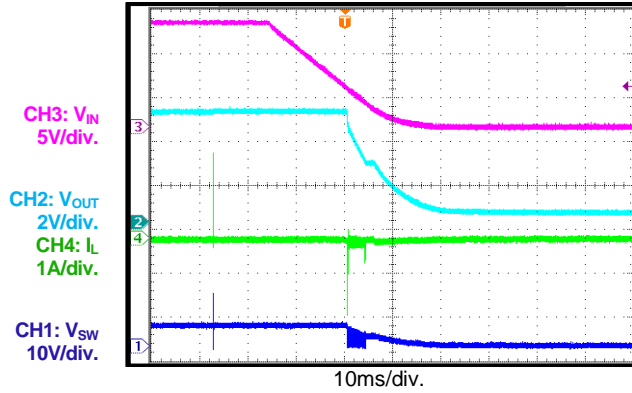
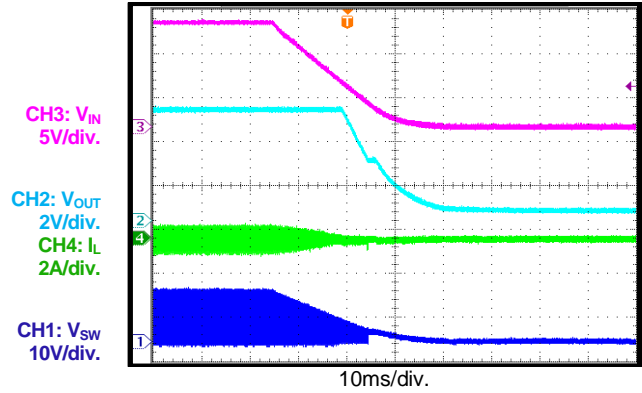
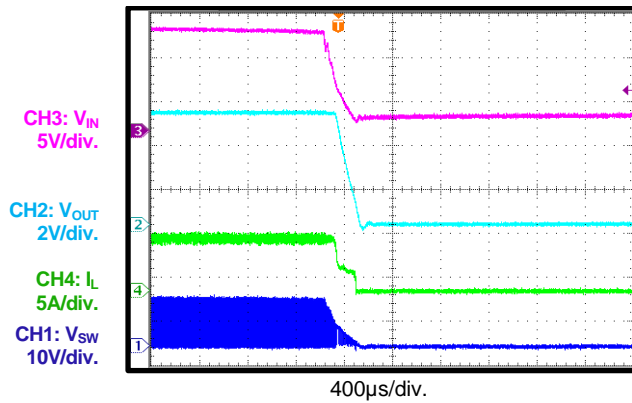
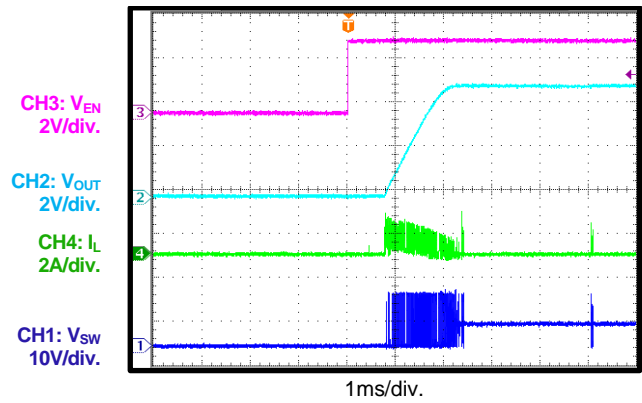
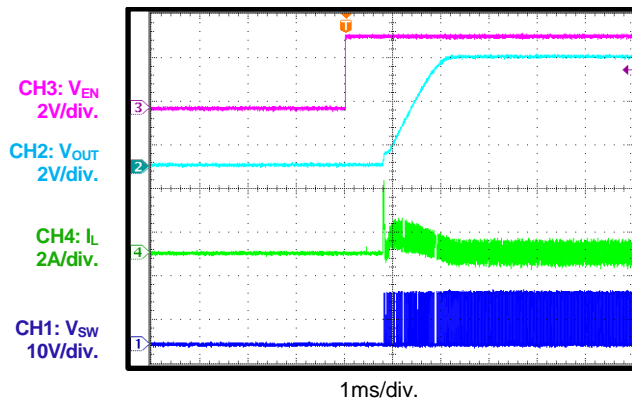
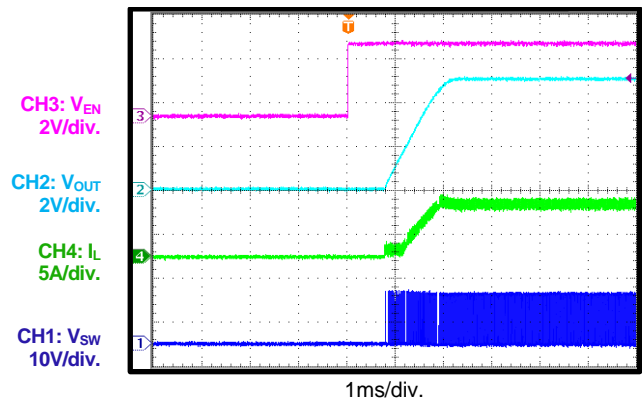
Start-Up through VIN

 I_{OUT} = 6A

TYPICAL PERFORMANCE CHARACTERISTICS (continued)
 $V_{IN} = 12V$, $V_{OUT} = 5V$, $L = 1\mu H$ ⁽⁷⁾, $f_{SW} = 2.2MHz$, AAM mode, $T_A = 25^\circ C$, unless otherwise noted.

Shutdown through VIN
 $I_{OUT} = 0A$, AAM mode

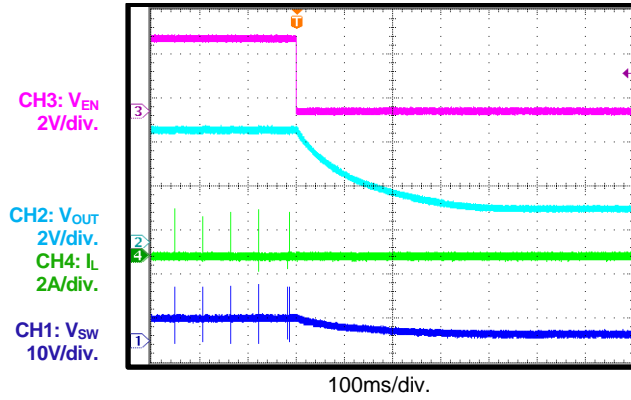
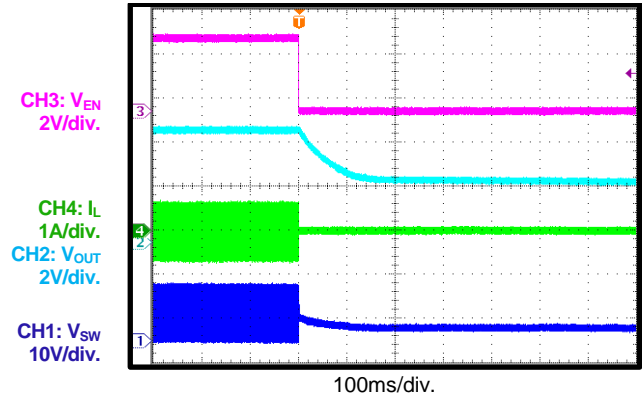
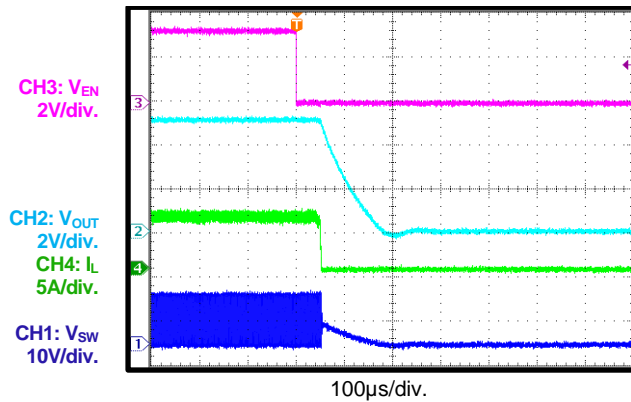
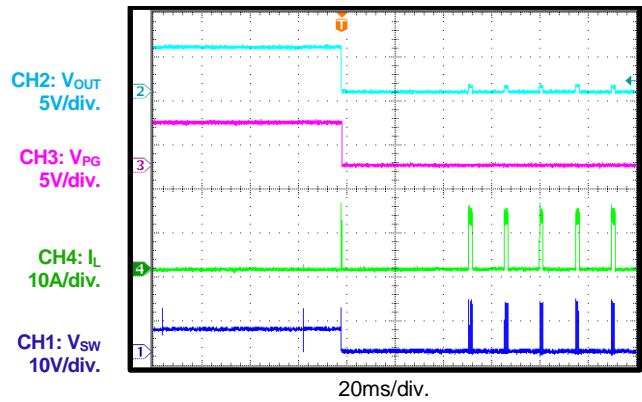
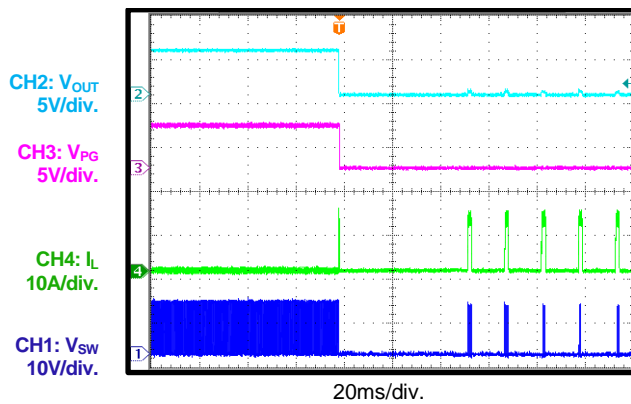
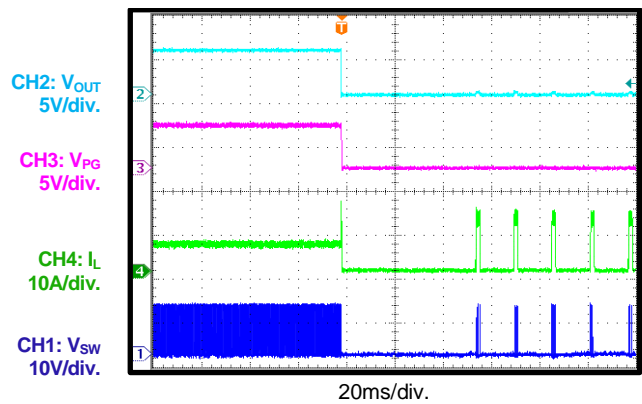
Shutdown through VIN
 $I_{OUT} = 0A$, FCCM

Shutdown through VIN
 $I_{OUT} = 6A$

Start-Up through EN
 $I_{OUT} = 0A$, AAM mode

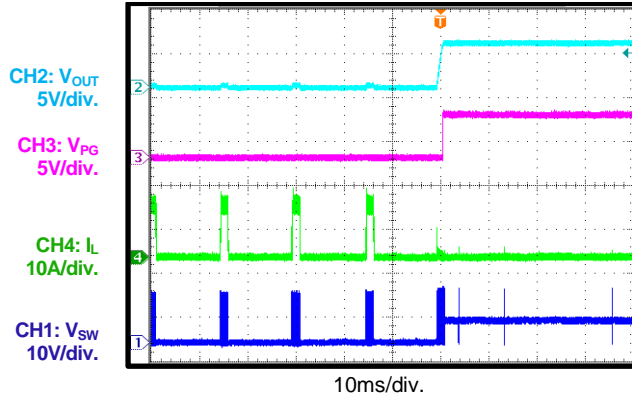
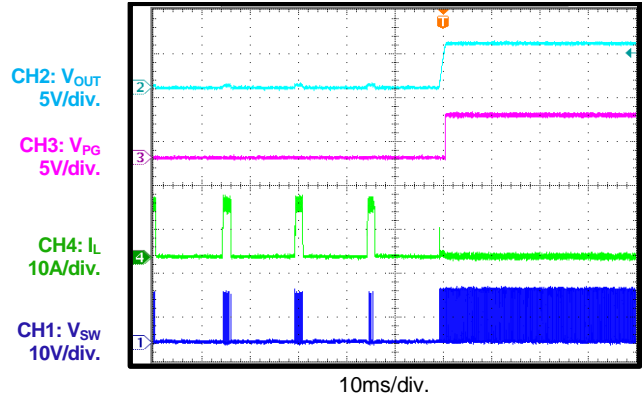
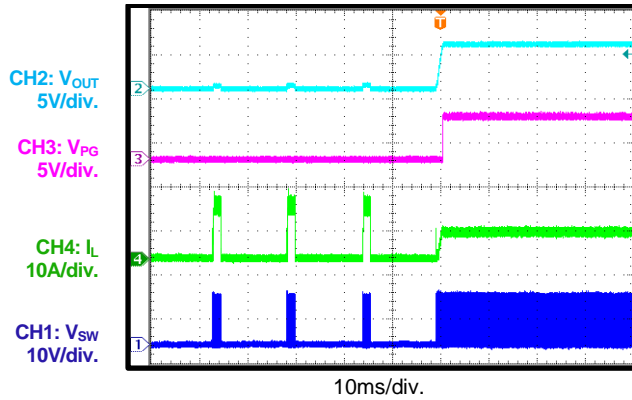
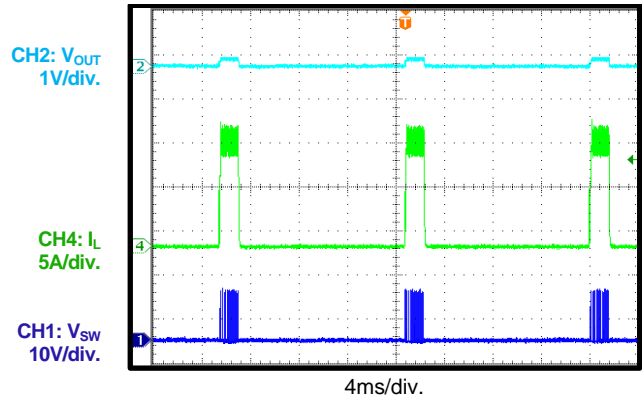
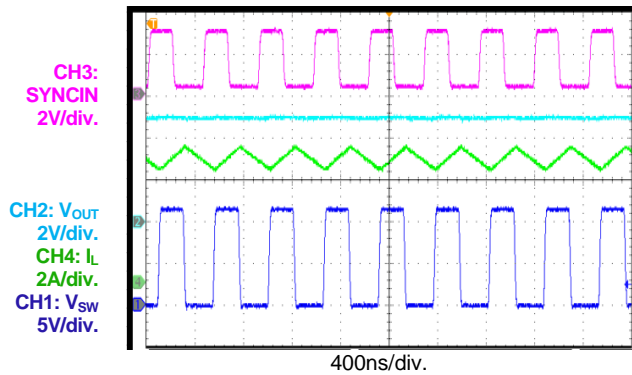
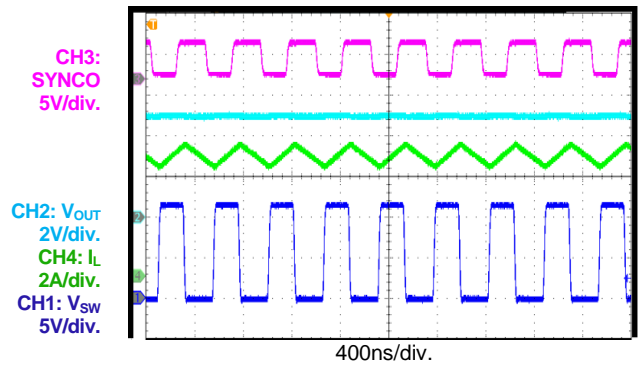
Start-Up through EN
 $I_{OUT} = 0A$, FCCM

Start-Up through EN
 $I_{OUT} = 6A$

TYPICAL PERFORMANCE CHARACTERISTICS (continued)
 $V_{IN} = 12V$, $V_{OUT} = 5V$, $L = 1\mu H$ ⁽⁷⁾, $f_{SW} = 2.2MHz$, AAM mode, $T_A = 25^\circ C$, unless otherwise noted.

Shutdown through EN
 $I_{OUT} = 0A$, AAM mode

Shutdown through EN
 $I_{OUT} = 0A$, FCCM

Shutdown through EN
 $I_{OUT} = 6A$

SCP Entry
 $I_{OUT} = 0A$, AAM mode

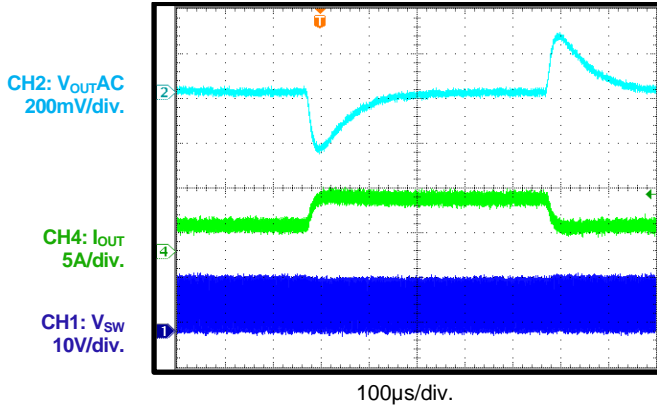
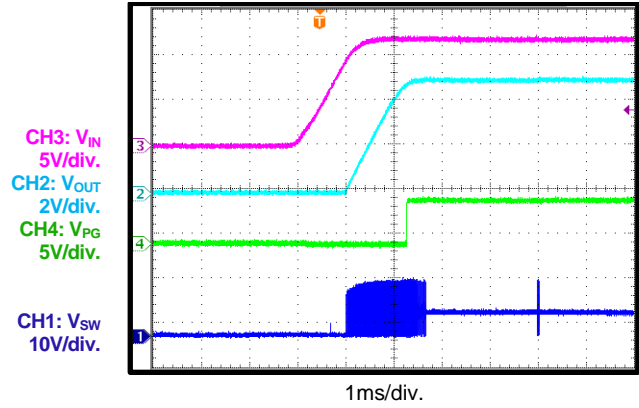
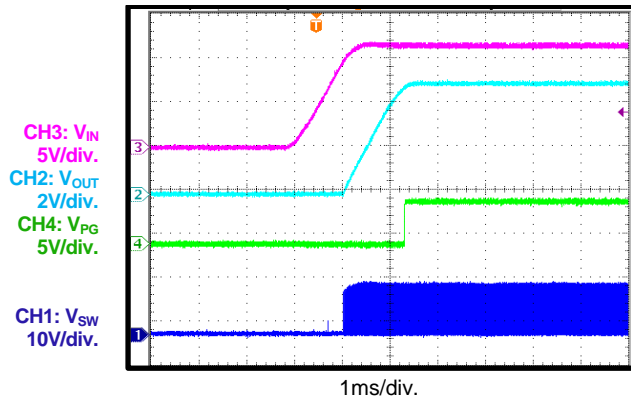
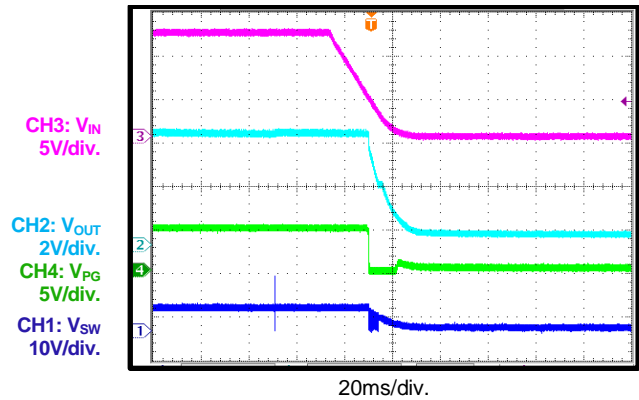
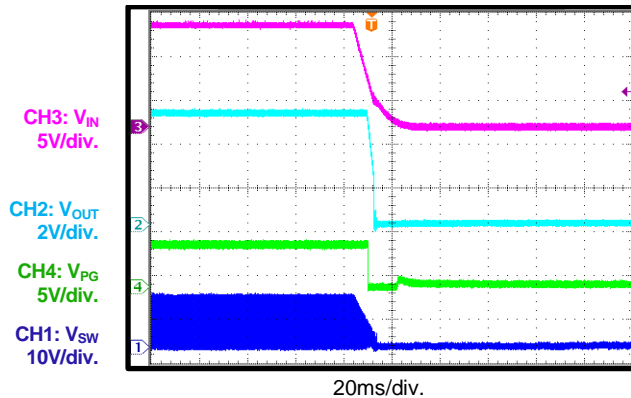
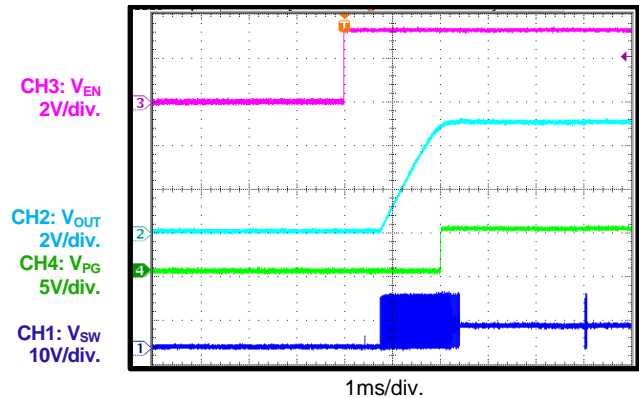
SCP Entry
 $I_{OUT} = 0A$, FCCM

SCP Entry
 $I_{OUT} = 6A$

TYPICAL PERFORMANCE CHARACTERISTICS (continued)
 $V_{IN} = 12V$, $V_{OUT} = 5V$, $L = 1\mu H$ ⁽⁷⁾, $f_{SW} = 2.2MHz$, AAM mode, $T_A = 25^\circ C$, unless otherwise noted.

SCP Recovery
 $I_{OUT} = 0A$, AAM mode

SCP Recovery
 $I_{OUT} = 0A$, FCCM

SCP Recovery
 $I_{OUT} = 6A$

SCP Steady State

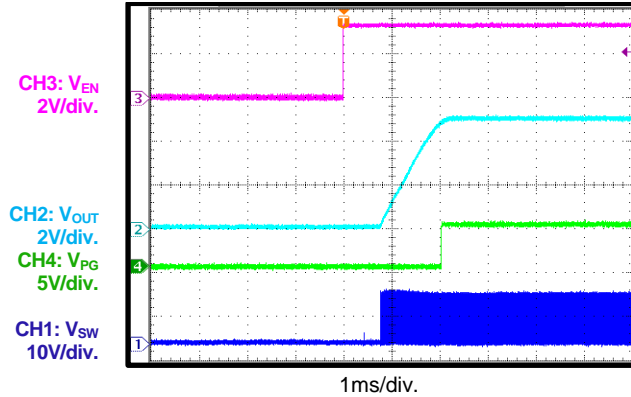
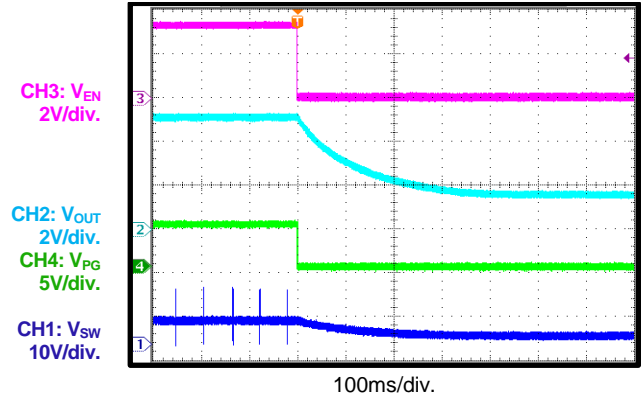
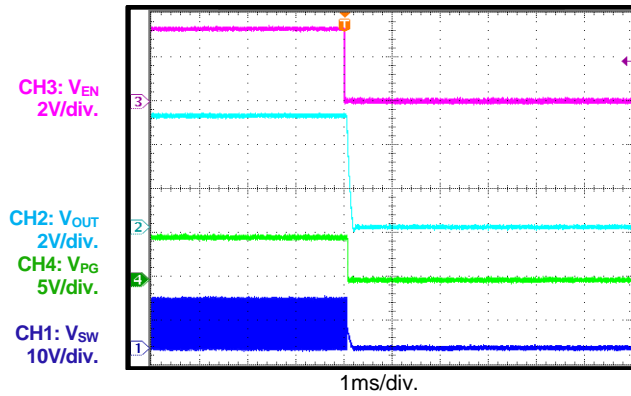
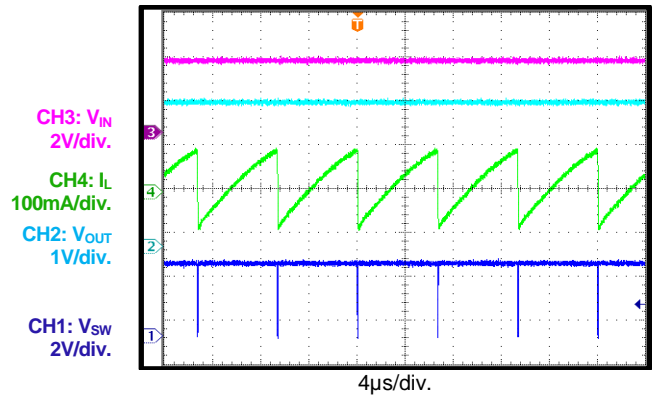
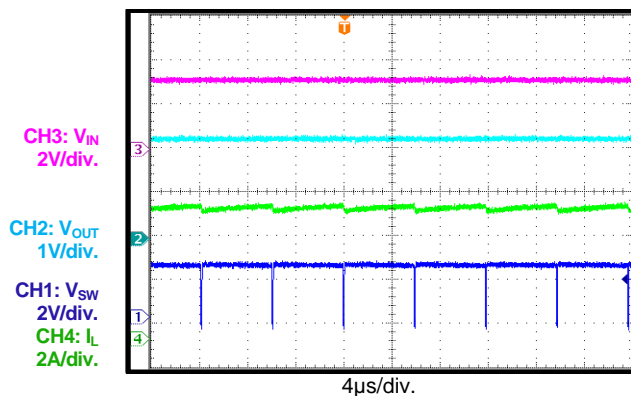
SYNC Operation
 $I_{OUT} = 6A$, SYNC frequency = 2.2MHz

SYNCO Operation
 $I_{OUT} = 6A$, SYNC frequency = 2.2MHz

TYPICAL PERFORMANCE CHARACTERISTICS (continued)
 $V_{IN} = 12V$, $V_{OUT} = 5V$, $L = 1\mu H$ ⁽⁷⁾, $f_{SW} = 2.2MHz$, AAM mode, $T_A = 25^\circ C$, unless otherwise noted.

Load Transient
 $I_{OUT} = 3A$ to $6A$, $1.6A/\mu s$

PG Start-Up through VIN
 $I_{OUT} = 0A$, AAM mode

PG Start-Up through VIN
 $I_{OUT} = 6A$

PG Shutdown through VIN
 $I_{OUT} = 0A$, AAM mode

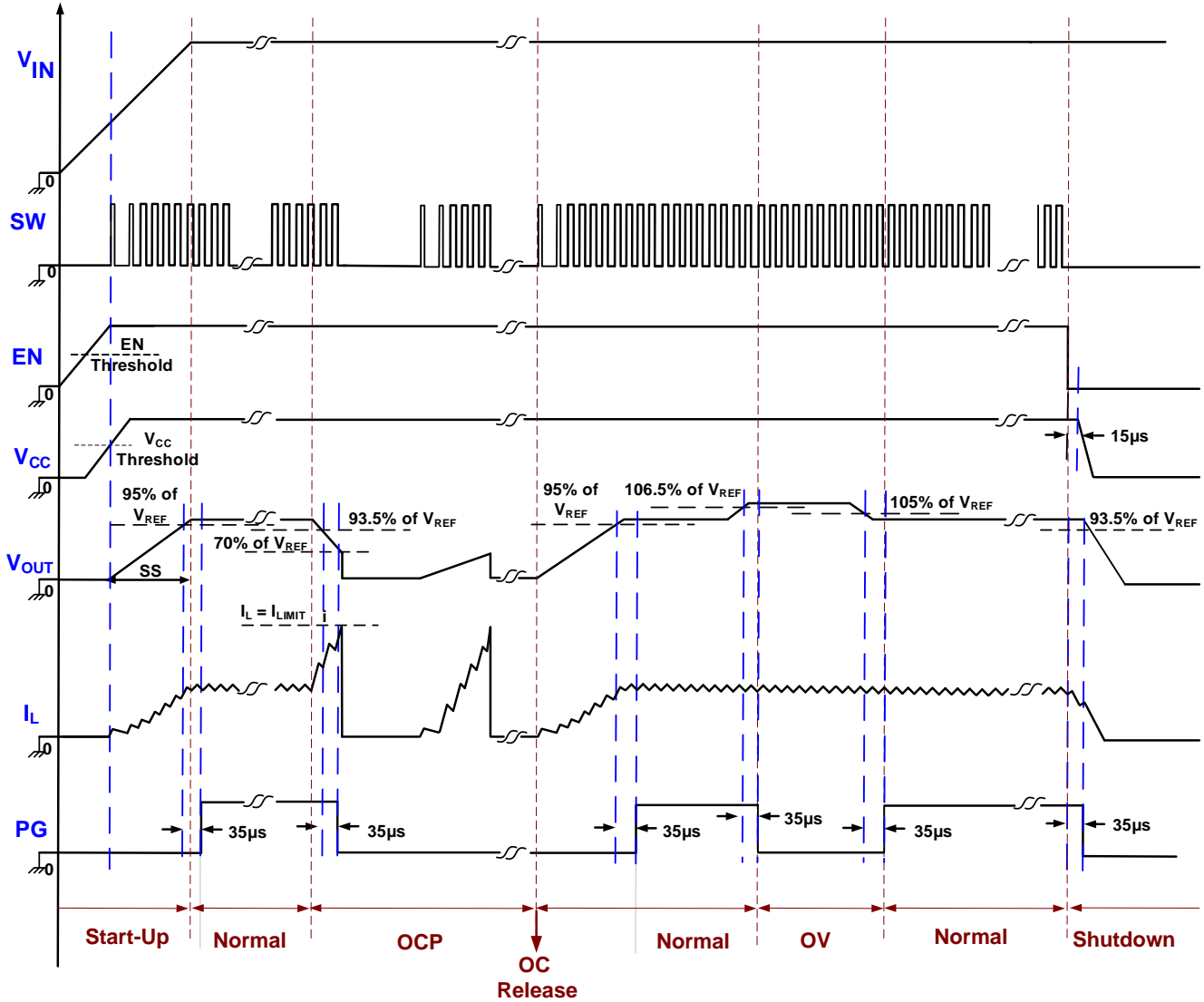
PG Shutdown through VIN
 $I_{OUT} = 6A$

PG Start-Up through EN
 $I_{OUT} = 0A$

TYPICAL PERFORMANCE CHARACTERISTICS (continued)
 $V_{IN} = 12V$, $V_{OUT} = 5V$, $L = 1\mu H$ ⁽⁷⁾, $f_{SW} = 2.2MHz$, AAM mode, $T_A = 25^\circ C$, unless otherwise noted.

PG Start-Up through EN
 $I_{OUT} = 6A$

PG Shutdown through EN
 $I_{OUT} = 0A$

PG Shutdown through EN
 $I_{OUT} = 6A$

Low-Dropout Mode
 $V_{IN} = 3.3V$, V_{OUT} set to 5V, $I_{OUT} = 0A$

Low-Dropout Mode
 $V_{IN} = 3.3V$, V_{OUT} set to 5V, $I_{OUT} = 6A$

Notes:

- 6) Inductor part number: XAL6060-472MEC. DCR = 15m Ω .
- 7) Inductor part number: XAL5030-102MEB. DCR = 8.5m Ω .

Timing Sequence

Figure 2: Timing Sequence

OPERATION

The MPQ4436B is a synchronous, step-down switching regulator with integrated internal high-side and low-side power MOSFETs (HS-FET and LS-FET, respectively). It provides 6A of highly efficient output current (I_{OUT}) with current mode control.

It features a wide input voltage (V_{IN}) range, configurable switching frequency (f_{SW}), external soft start (SS), and precision current limiting. Its very low operational quiescent current (I_Q) makes it ideal for battery-powered applications.

PWM Control

At moderate to high output currents, the MPQ4436B operates in fixed-frequency, peak current control mode to regulate the output voltage (V_{OUT}). A PWM cycle is initiated by the internal clock. At the rising edge of the clock, the HS-FET turns on and remains on until its current reaches the value set by the internal COMP voltage (V_{COMP}). Once the HS-FET is on, it remains on for at least 100ns.

When the HS-FET is off, the LS-FET turns on immediately and remains on until the next cycle starts. Once the LS-FET is on, it remains on for at least 80ns before next cycle starts.

If the current in the HS-FET does not reach the COMP-set current value within one PWM period, then the HS-FET remains on, saving a turn-off operation. If the on time lasts about 10 μ s, then the HS-FET is forced off even though COMP is not reached.

Light-Load Operation

Under light-load conditions, the MPQ4436B can work in two different operation modes by setting the MODE pin to one of two different statuses .

The MPQ4436B works in forced continuous conduction mode (FCCM) when the MODE pin is pulled above 1.8V. In this mode, the part works with a fixed frequency from no load to full load. The advantage of FCCM is the controllable frequency and lower output ripple at light loads.

The MPQ4436B works in asynchronous advanced modulation (AAM) mode when the MODE pin is pulled below 0.4V. AAM is meant to optimize the efficiency during light-load and no-load conditions.

When AAM mode is enabled, the MPQ4436B first enters asynchronous operation as long as the inductor current (I_L) approaches 0A at light load. If the load is further decreased or there is no load that makes V_{COMP} decrease to the set value, the MPQ4436B enters AAM mode. In AAM mode, the internal clock is reset every time V_{COMP} crosses over the set value. The crossover time is taken as the benchmark of the next clock. When the load increases and V_{COMP} exceeds the set value, the operation mode is discontinuous conduction mode (DCM) or CCM, which has a constant f_{SW} (see Figure 3).

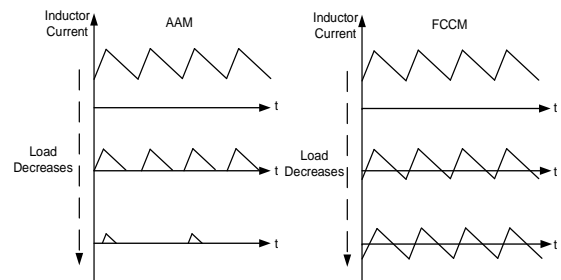

Figure 3: AAM and FCCM

Error Amplifier (EA)

The error amplifier (EA) compares the FB pin's voltage (V_{FB}) with the internal reference voltage (V_{REF} , typically 0.815V) and outputs a current proportional to the difference between the two. This current is then used to charge the compensation network to form V_{COMP} , which is used to control the power MOSFET current.

During operation, the minimum V_{COMP} is clamped to 0.9V, and the maximum V_{COMP} is clamped to 2V. COMP is internally pulled down to GND in shutdown mode.

Internal Regulator VCC

Most of the internal circuitry is powered by the internal 4.9V VCC regulator. This regulator takes V_{IN} as the input and operates across the full V_{IN} range. When V_{IN} exceeds 4.9V, VCC is in full regulation. When V_{IN} is below this point, the output VCC voltage (V_{CC}) degrades.

Bootstrap (BST) Charging

The bootstrap (BST) capacitor (C_{BST}) is charged and regulated to about 5V by the dedicated internal BST regulator. When the voltage between the BST and SW nodes is below its

regulation value, a PMOS pass transistor connected from VCC to BST turns on to charge C_{BST} .

External circuitry should provide enough voltage headroom to facilitate charging. When the HS-FET is on, BST is above VCC, so C_{BST} cannot be charged.

At higher duty cycles, the time period available for BST charging is shorter, so C_{BST} may not be charged sufficiently. If the external circuit has not had sufficient voltage and time to charge C_{BST} , extra external circuitry can be used to ensure that the bootstrap voltage (V_{BST}) is within the normal operation range.

Low-Dropout Mode and BST Refresh

To improve dropout, the MPQ4436B is designed to operate at close to 100% duty cycle as long as the BST-to-SW voltage is greater than 2.5V. When the voltage from BST to SW drops below 2.5V, the HS-FET turns off using an under-voltage lockout (UVLO) circuit, which allows the LS-FET to conduct and refresh the charge on C_{BST} . In DCM or pulse-skip mode (PSM), the LS-FET is forced on to refresh V_{BST} .

Since the supply current sourced from C_{BST} is low, the HS-FET remains on for more switching cycles than are required to refresh the capacitor. Therefore, the effective duty cycle of the switching regulator is high.

The effective duty cycle during dropout of the regulator is mainly influenced by the voltage drops across the power MOSFET, inductor resistance, the low-side diode, and PCB resistance.

Enable (EN) Control

EN is a digital control pin that turns the regulator on and off (see Figure 4).

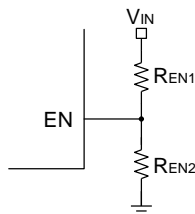

Figure 4: Enable Divider Circuit

It offers two main features:

1. EN is enabled by an external logic (H/L) signal. When EN is pulled below the falling

voltage threshold (0.85V), the chip is put into the lowest shutdown current mode. Forcing this pin above the EN rising threshold voltage (1V) turns on the part.

2. EN can configure V_{IN} UVLO. With high enough V_{IN} , the chip can be enabled and disabled by the EN pin. With the internal current source, this circuit can generate a programmable V_{IN} UVLO and hysteresis.

Configurable Frequency and Foldback

The MPQ4436B's oscillating frequency is programmed either by an external resistor (R_{FREQ}) from the FREQ pin to ground, or by a logic-level SYNC signal. To get an expected f_{SW} select the R_{FREQ} value following the f_{SW} vs. R_{FREQ} curve (see the Typical Performance Characteristics section on page 15).

When f_{SW} is high, it folds back at high input voltages to avoid triggering the minimum on time (t_{ON_MIN}) and the output going out of regulation. When an external sync clock is present, this frequency foldback function is disabled. See the f_{SW} vs. V_{IN} curve in the Typical Performance Characteristics section on page 15 for an example when R_{FREQ} is 12k Ω . The MPQ4436B can support $f_{SW} \leq 2.2$ MHz applications (except for $V_{OUT} < 5$ V applications).

For $V_{OUT} < 5$ V applications, t_{ON_MIN} is triggered at high input voltages, and the output may go out of regulation, which should be avoided. Therefore, the recommended f_{SW} range for $V_{OUT} < 5$ V applications (such as car battery applications) is 350kHz to 1000kHz. Higher frequencies may still be supported for applications that do not have critical limits on f_{SW} or have relatively low, stable input voltages. Table 1 lists the recommended R_{FREQ} values for common frequencies.

Table 1: Resistor Selection for f_{SW} Values

| R_{FREQ} (k Ω) | f_{SW} (kHz) |
|--------------------------|----------------|
| 86.6 | 350 |
| 75 | 410 |
| 62 | 470 |
| 54.9 | 530 |
| 45.3 | 640 |
| 37.4 | 760 |
| 34 | 830 |
| 26.1 | 1000 |
| 20 | 1300 |
| 15 | 1750 |
| 12 | 2200 |

Soft Start (SS)

Soft start (SS) is implemented to prevent the converter's V_{OUT} from overshooting during start-up.

When the soft-start time (t_{SS}) starts, an internal current source begins charging the external soft-start capacitor (C_{SS}). When the soft-start voltage (V_{SS}) falls below the V_{REF} , V_{SS} overrides V_{REF} and the EA uses V_{SS} as the reference. When V_{SS} exceeds V_{REF} , V_{REF} is used as the reference. C_{SS} can be calculated with Equation (1):

$$C_{SS}(\text{nF}) = \frac{t_{SS}(\text{ms}) \times I_{SS}(\mu\text{A})}{V_{REF}(\text{V})} = 6.25 \times t_{SS}(\text{ms}) \quad (1)$$

The SS pins can be used for tracking and sequencing.

Pre-Biased Start-Up

For the MPQ4436B, if $V_{FB} > V_{SS} - 150\text{mV}$ at start-up (which means the output has a pre-biased voltage), neither the HS-FET nor LS-FET are turned on until V_{SS} exceeds V_{FB} .

Thermal Shutdown

Thermal shutdown is implemented to prevent the chip from thermally running away. If the silicon die temperature exceeds its upper threshold (170°C), the power MOSFETs shut down. When the temperature falls below its lower threshold (150°C), the chip is enabled again.

Current Comparator and Current Limit

The power MOSFET current is accurately sensed via a current-sense MOSFET. It is then fed to the high-speed current comparator for current mode control. The current comparator takes this sensed current as one of its inputs.

When the HS-FET turns on, the comparator is blanked until the end of the turn-on transition to avoid noise. Then the comparator compares the power MOSFET current with V_{COMP} . When the sensed current exceeds V_{COMP} , the comparator outputs low to turn off the HS-FET. The internal power MOSFET's maximum current is internally limited cycle by cycle.

Hiccup Protection

If the output is shorted to ground, causing V_{OUT} to drop below 70% of its nominal voltage, the IC shuts down momentarily and begins discharging C_{SS} . It restarts with a full SS when C_{SS} is fully discharged. This hiccup process repeats until the

fault condition is removed.

Start-Up and Shutdown

If both V_{IN} and EN exceed their respective thresholds, the chip starts. The reference block starts first, generating a stable reference voltage and currents, and then the internal regulator is enabled. The regulator provides a stable supply for the remaining circuitries.

While the internal supply rail is up, an internal timer holds the power MOSFET off for about 50 μs to blank any start-up glitches. When the SS block is enabled, it first holds V_{SS} low to ensure the remaining circuitries are ready, then slowly ramps up.

Three events can shut down the chip: EN going low, V_{IN} going low, and thermal shutdown. During the shutdown procedure, the signaling path is blocked first to avoid any fault triggering. V_{COMP} and the internal supply rail are then pulled down. The floating driver is not subject to this shutdown command, but its charging path is disabled.

Power Good (PG) Output

The MPQ4436B includes an open-drain power good (PG) output that indicates the output. A pull-up resistor connected to the power source is required if PG is used. If V_{OUT} is within 95% to 105% of the nominal voltage, the PG pin goes high. If V_{OUT} is above 106.5% or below 93.5% of the nominal voltage, PG goes low.

SYNCIN and SYNCO

f_{SW} can be synced to the rising edge of the clock signal applied at SYNCIN. The recommended SYNCIN frequency range is 350kHz to 2.2MHz (except for $V_{OUT} < 5\text{V}$ applications). Ensure that the SYNCIN off time is shorter than the internal oscillator period; otherwise the internal clock may turn on the HS-FET before the rising edge of SYNCIN. There is no other special limit on the pulse width of SYNCIN, but there is always parasitic capacitance of the pad. If the pulse width is too short, a clear rising and falling edge may not be seen due to the parasitic capacitance. A pulse longer than 100ns is recommended in most applications.

When applying SYNCIN in AAM mode, pull SYNCIN below its threshold (0.4V) or leave SYNCIN floating before the MPQ4436B starts up, and then adding external SYNCIN clock.

To avoid floating SYNCIN when using this function through an external clock, connect a resistor to GND. Considering SYNCIN's drive capability, it is recommended to use a 10kΩ to 51kΩ resistor.

The SYNCO pin provides a default 180° phase-shifted clock to the internal oscillator. If there is no external SYNCIN clock, then SYNCO provides a 180° phase-shifted clock that is compared to the internal clock. If there is an external SYNCIN clock, then SYNCO provides a 180° phase-shifted clock that is compared to the external SYNCIN clock (see Figure 5). This makes enabling a dual-phase, interleaved configuration easy (see Figure 6).

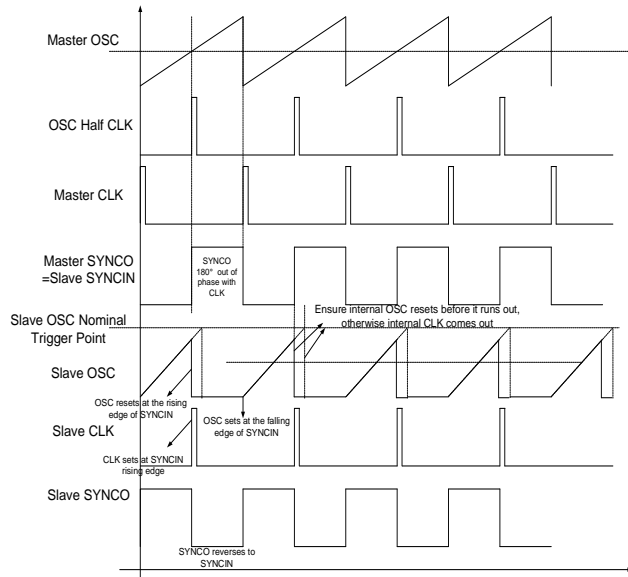

Figure 5: SYNCIN and SYNCO Scheme

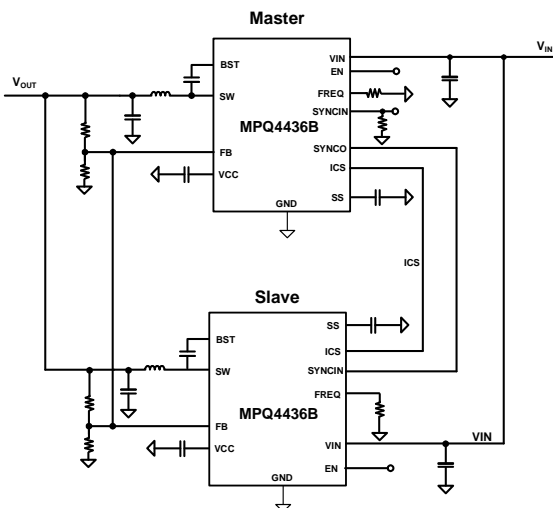

Figure 6: Dual-Phase Configuration

For multi-phase applications, the V_{OUT}, FB, and ICS pins of the chips in parallel must be connected together. SYNCO of the master is connected to the SYNCIN pin of the slave for phase-interleaved configurations (see Figure 7).

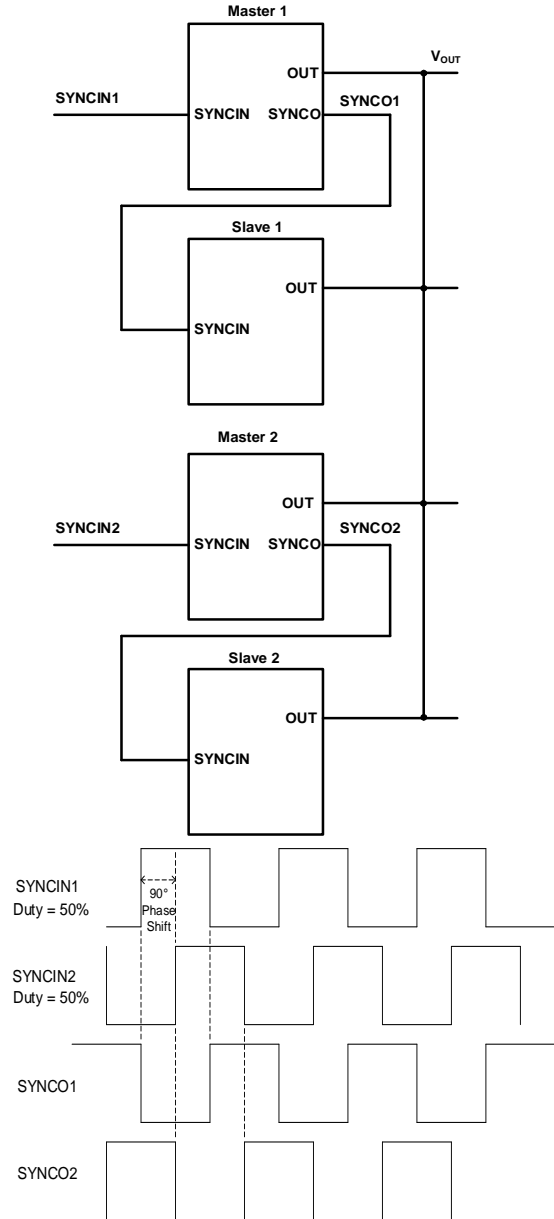

Figure 7: Four-Phase Configuration

APPLICATION INFORMATION

Setting the Output Voltage

The external resistor divider connected to FB sets V_{OUT} (see Figure 8).

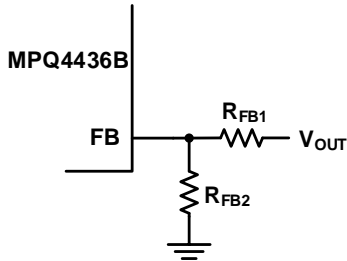

Figure 8: Feedback Network

Calculate R_{FB2} with Equation (2):

$$R_{FB2} = \frac{R_{FB1}}{\frac{V_{OUT}}{0.815V} - 1} \quad (2)$$

Table 2 lists the recommended feedback resistor values for common output voltages.

Table 2: Resistor Selection for Output Voltages

| V _{OUT} (V) | R _{FB1} (kΩ) | R _{FB2} (kΩ) |
|----------------------|-----------------------|-----------------------|
| 3.3 | 100 (1%) | 32.4 (1%) |
| 5 | 100 (1%) | 19.6 (1%) |

Setting the Output Voltage

The step-down converter has a discontinuous input current, and requires a capacitor to supply AC current to the converter while maintaining the DC input voltage. For the best performance, use low-ESR capacitors. Ceramic capacitors with X5R or X7R dielectrics are highly recommended because of their low ESR and small temperature coefficients.

For most applications, it is recommended to use a 4.7μF to 10μF capacitor. It is strongly recommended to use another, lower-value capacitor (e.g. 0.1μF) with a small package size (0603) to absorb high-frequency switching noise. Place the smaller capacitor as close to V_{IN} and GND as possible.

Since the input capacitor (C_{IN}) absorbs the input switching current, it requires an adequate ripple current rating. The RMS current in C_{IN} can be estimated with Equation (3):

$$I_{CIN} = I_{LOAD} \times \sqrt{\frac{V_{OUT}}{V_{IN}} \times \left(1 - \frac{V_{OUT}}{V_{IN}}\right)} \quad (3)$$

The worst-case condition occurs at V_{IN} = 2 × V_{OUT}, calculated with Equation (4):

$$I_{CIN} = \frac{I_{LOAD}}{2} \quad (4)$$

For simplification, choose an input capacitor with an RMS current rating greater than half of the maximum load current.

The input capacitor can be electrolytic, tantalum, or ceramic. When using electrolytic or tantalum capacitors, add a small, high-quality ceramic capacitor (e.g. 0.1μF) placed as close to the IC as possible. When using ceramic capacitors, ensure that they have enough capacitance to provide a sufficient charge to prevent excessive voltage ripple at the input. The input voltage ripple (ΔV_{IN}) caused by the capacitance can be estimated with Equation (5):

$$\Delta V_{IN} = \frac{I_{LOAD}}{f_{SW} \times C_{IN}} \times \frac{V_{OUT}}{V_{IN}} \times \left(1 - \frac{V_{OUT}}{V_{IN}}\right) \quad (5)$$

Selecting the Output Capacitor

The output capacitor maintains the DC output voltage. Use ceramic, tantalum, or low-ESR electrolytic capacitors. For best results, use low-ESR capacitors to keep the output voltage ripple low. The output voltage ripple (ΔV_{OUT}) can be estimated with Equation (6):

$$\Delta V_{OUT} = \frac{V_{OUT}}{f_{SW} \times L} \times \left(1 - \frac{V_{OUT}}{V_{IN}}\right) \times \left(R_{ESR} + \frac{1}{8f_{SW} \times C_{OUT}}\right) \quad (6)$$

Where L is the inductance, and R_{ESR} is the equivalent series resistance (ESR) value of the output capacitor.

For ceramic capacitors, the capacitance dominates the impedance at the switching frequency and causes the majority of the output voltage ripple. For simplification, the output voltage ripple (ΔV_{OUT}) can be estimated with Equation (7):

$$\Delta V_{OUT} = \frac{V_{OUT}}{8 \times f_{SW}^2 \times L \times C_{OUT}} \times \left(1 - \frac{V_{OUT}}{V_{IN}}\right) \quad (7)$$

For tantalum or electrolytic capacitors, the ESR dominates the impedance at the switching frequency. For simplification, the output voltage ripple (ΔV_{OUT}) can be estimated with Equation (8) on page 38:

$$\Delta V_{OUT} = \frac{V_{OUT}}{f_{SW} \times L} \times \left(1 - \frac{V_{OUT}}{V_{IN}}\right) \times R_{ESR} \quad (8)$$

The characteristics of the output capacitor also affect the stability of the regulation system. The MPQ4436B can be optimized for a wide range of capacitances and ESR values.

Selecting the Inductor

A 1μH to 10μH inductor with a DC current rating at least 25% greater than the maximum load current is recommended for most applications. For higher efficiency, choose an inductor with a lower DC resistance. A larger-value inductor results in less ripple current and a lower output ripple voltage; however, it also has a larger physical size, higher series resistance, and lower saturation current. A good rule for determining the inductance is to allow the inductor ripple current to be approximately 30% of the maximum load current. The inductance (L) can be calculated with Equation (9):

$$L = \frac{V_{OUT}}{f_{SW} \times \Delta I_L} \times \left(1 - \frac{V_{OUT}}{V_{IN}}\right) \quad (9)$$

Where ΔI_L is the peak-to-peak inductor ripple current.

Choose the inductor ripple current to be approximately 30% of the maximum load current. The maximum peak inductor current (I_{LP}) can be calculated with Equation (10):

$$I_{LP} = I_{LOAD} + \frac{V_{OUT}}{2f_{SW} \times L} \times \left(1 - \frac{V_{OUT}}{V_{IN}}\right) \quad (10)$$

V_{IN} UVLO Setting

The MPQ4436B has an internal, fixed under-voltage lockout (UVLO) threshold. The rising threshold is 3V, while the falling threshold is about 2.7V. For applications that require a higher UVLO point, an external resistor divider between V_{IN} and EN can be used to achieve a higher equivalent UVLO threshold (see Figure 9).

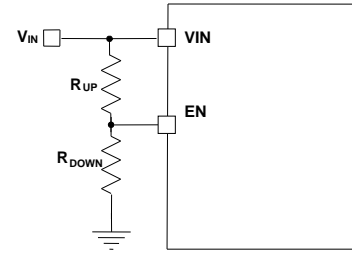

Figure 9: Adjustable UVLO Using EN Divider

The UVLO rising and falling thresholds can be calculated with Equation (11) and Equation (12), respectively:

$$V_{IN_UVLO_RISING} = \left(1 + \frac{R_{UP}}{R_{DOWN}}\right) \times V_{EN_RISING} \quad (11)$$

$$V_{IN_UVLO_FALLING} = \left(1 + \frac{R_{UP}}{R_{DOWN}}\right) \times V_{EN_FALLING} \quad (12)$$

Where V_{EN_RISING} is 1V, and $V_{EN_FALLING}$ is 0.85V.

External BST Diode and Resistor

An external BST diode can enhance the efficiency of the regulator when the duty cycle is high. A power supply between 2.5V and 5V can be used to power the external BST diode. V_{CC} or V_{OUT} is recommended to be this power supply in the circuit (see Figure 10).

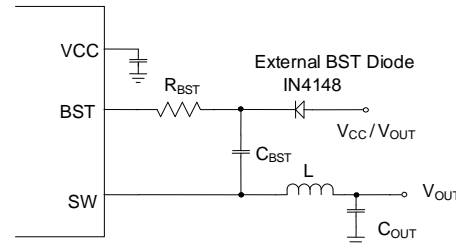

Figure 10: Optional External Bootstrap Diode to Enhance Efficiency

The recommended external BST diode is IN4148, and the recommended C_{BST} value is 0.1μF to 1μF. A resistor in series with C_{BST} (R_{BST}) can reduce the SW rising rate and voltage spikes. This enhances EMI performance and reduces voltage stress at a high V_{IN}. A higher resistance improves SW spike reduction but compromises efficiency. To make a tradeoff between EMI and efficiency, a ≤20Ω R_{BST} is recommended.

Setting the VCC Capacitor

The VCC capacitor should be 10 times the value of the boost capacitor, and at least 4.7μF nominal. A VCC capacitor greater than 68μF nominal is not recommended.

PCB Layout Guidelines ⁽⁸⁾

Efficient PCB layout, especially input capacitor placement, is critical for stable operation. A 4-layer layout is strongly recommended to achieve better thermal performance. For best results, refer to Figure 11 and follow the guidelines below:

1. Place symmetric input capacitors as close to VIN and GND as possible.
2. Connect a large ground plane directly to PGND.
3. If the bottom layer is a ground plane, add vias near PGND.
4. Ensure that the high-current paths at GND and VIN have short, direct, and wide traces.
5. Place the ceramic input capacitor, especially the small package size (0603) input bypass capacitor, as close to VIN and PGND as possible to minimize high-frequency noise.
6. Keep the connection between the input capacitor and VIN as short and wide as possible.
7. Place the VCC capacitor as close to VCC and GND as possible.
8. Route SW and BST away from sensitive analog areas, such as FB.
9. Place the feedback resistors close to the chip to ensure the trace that connects to FB is as short as possible.
10. Use multiple vias to connect the power planes to the internal layers.

Note:

- 8) The recommended PCB layout is based on Figure 12 on page 40.

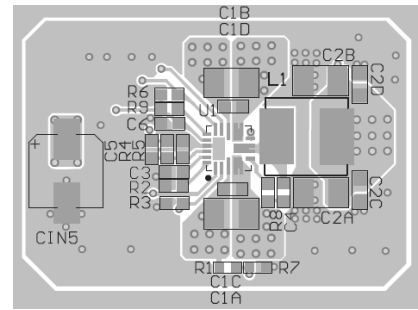

Top Layer

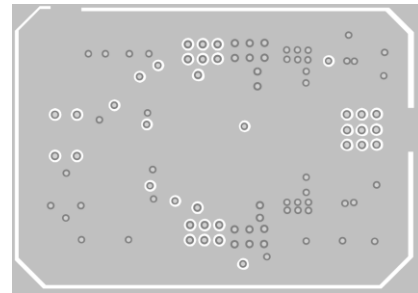

Mid-Layer 1

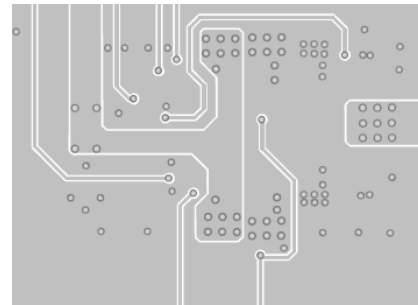

Mid-Layer 2

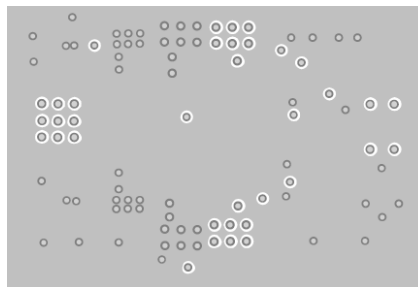

Bottom Layer

Figure 11: Recommended PCB Layout

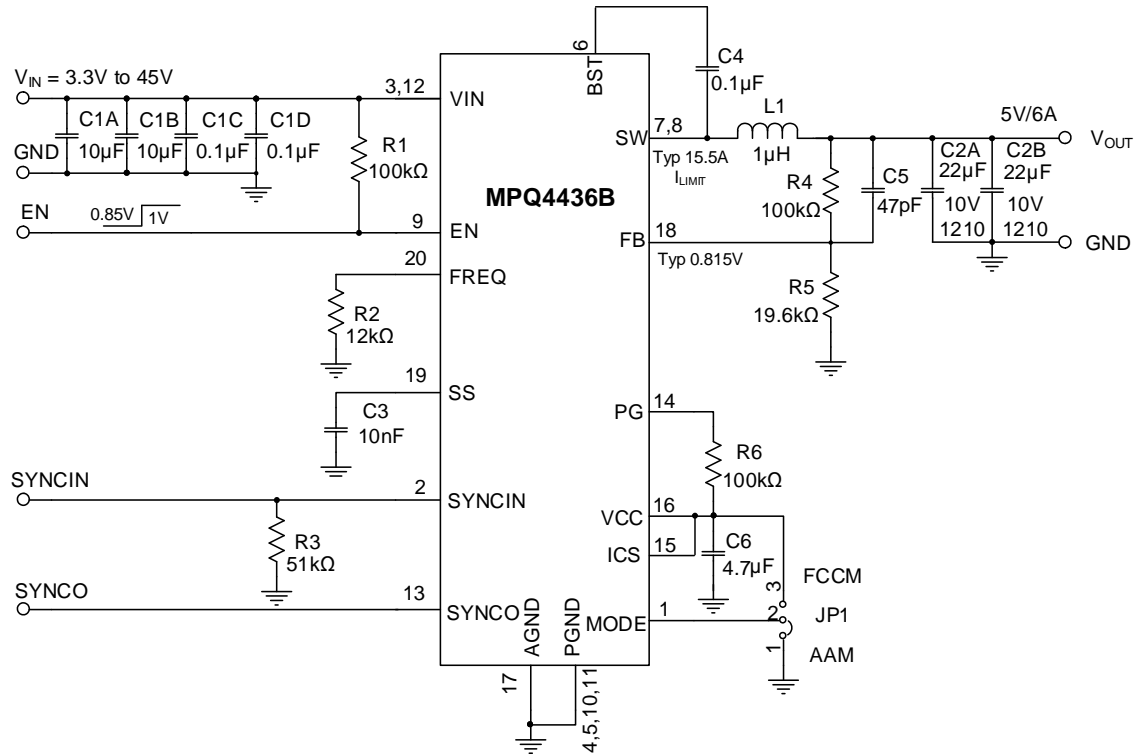
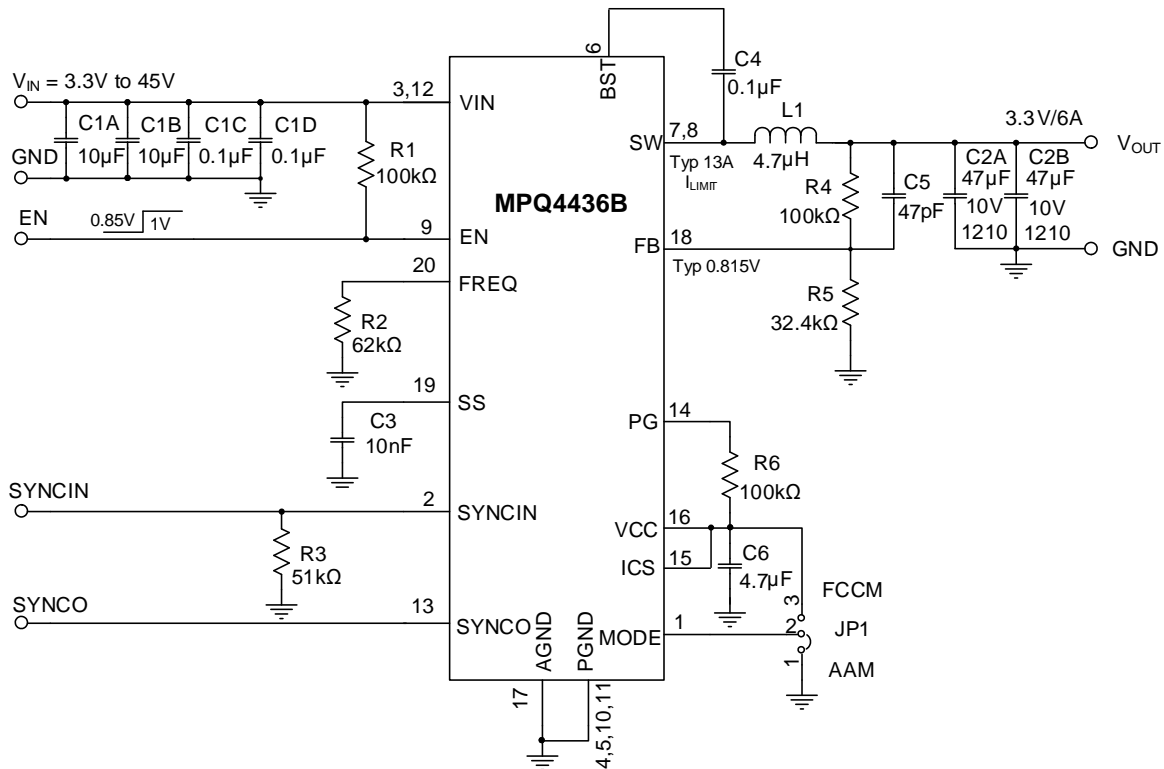
TYPICAL APPLICATION

Figure 12: Typical Single-Phase Application Circuit ($V_{OUT} = 5V$, $f_{SW} = 2.2MHz$)

Figure 13: Typical Single-Phase Application Circuit ($V_{OUT} = 3.3V$, $f_{SW} = 470kHz$)

TYPICAL APPLICATION (continued)

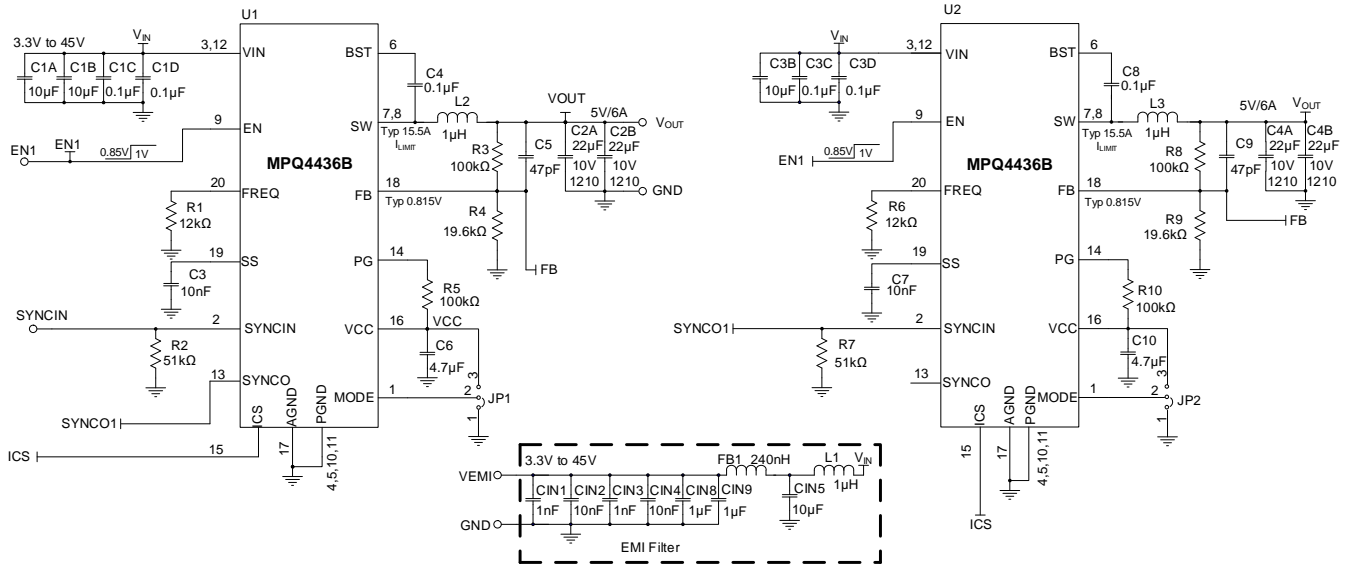

Figure 14: Typical Dual-Phase Application Circuit ($V_{OUT} = 5V$, $f_{sw} = 2.2MHz$)

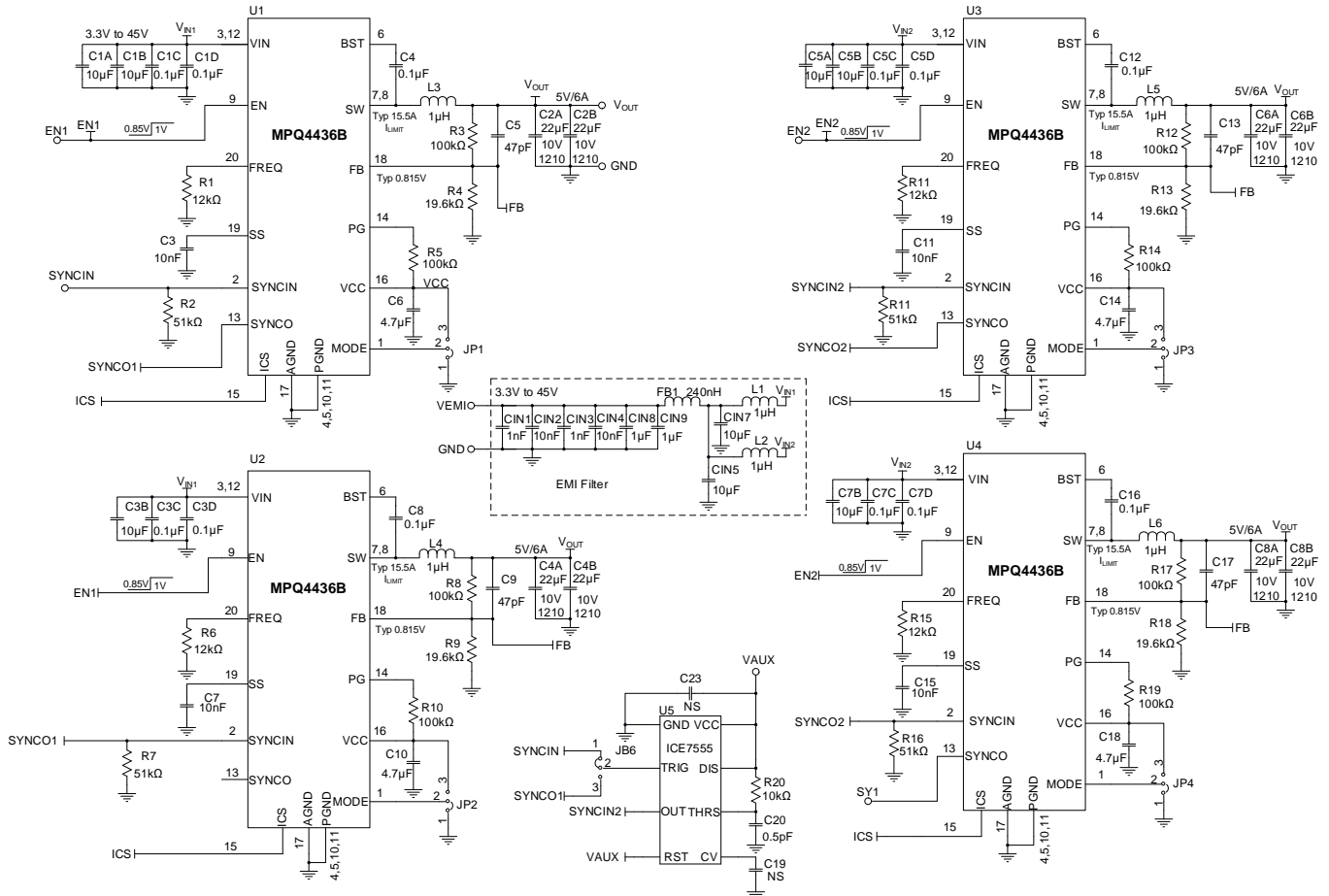
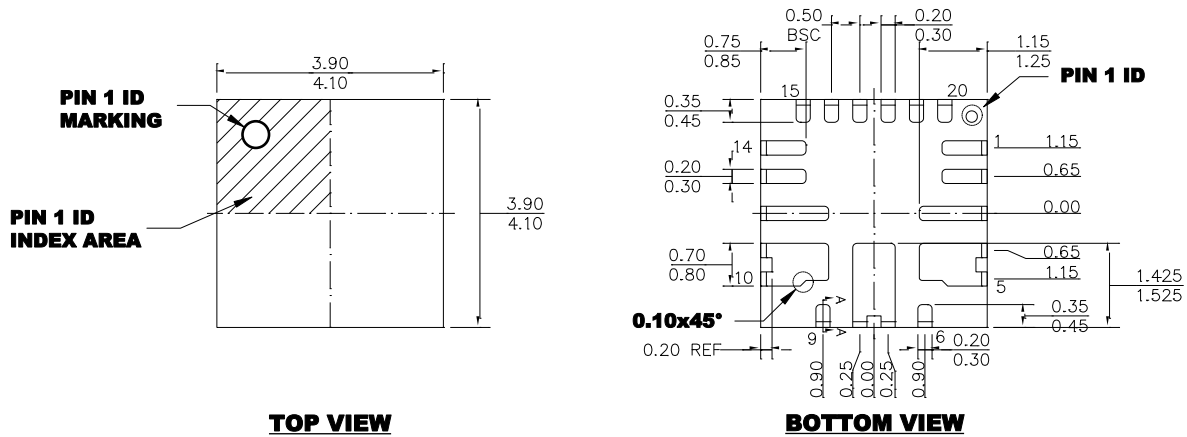

Figure 15: Typical Four-Phase Application Circuit ($V_{OUT} = 5V$, $f_{sw} = 2.2MHz$)

PACKAGE INFORMATION

QFN-20 (4mmx4mm) Wettable Flank



SIDE VIEW

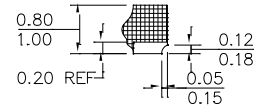

SECTION A-A

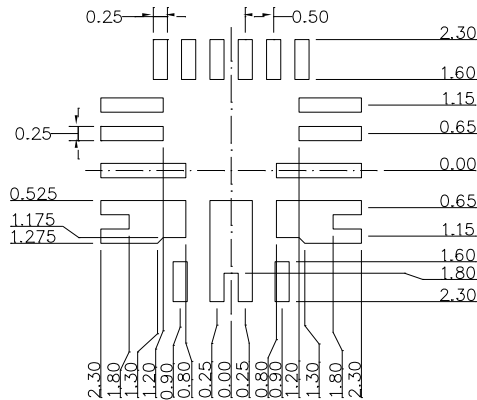

RECOMMENDED LAND PATTERN

NOTE:

- 1) THE LEAD SIDE IS WETTABLE.
- 2) ALL DIMENSIONS ARE IN MILLIMETERS.
- 3) LEAD COPLANARITY SHALL BE 0.08 MILLIMETERS MAX.
- 4) JEDEC REFERENCE IS MO-220.
- 5) DRAWING IS NOT TO SCALE.

CARRIER INFORMATION

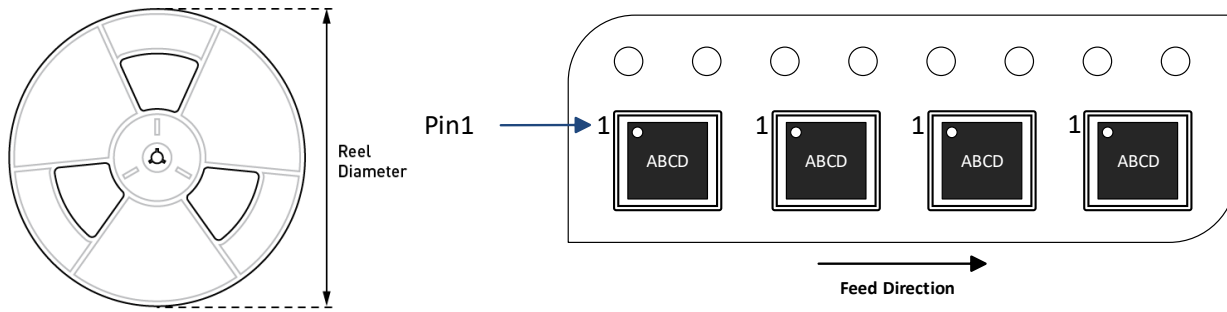

| Part Number | Package Description | Quantity/ Reel | Quantity/ Tube ⁽⁹⁾ | Reel Diameter | Carrier Tape Width | Carrier Tape Pitch |
|--------------------|---------------------|----------------|-------------------------------|---------------|--------------------|--------------------|
| MPQ4436BGRE-AEC1-Z | QFN-20 (4mmx4mm) | 5000 | N/A | 13in | 12mm | 8mm |
| MPQ4436BGRE-Z | QFN-20 (4mmx4mm) | 5000 | N/A | 13in | 12mm | 8mm |

Note:

9) N/A indicates “not available” in tubes. For 500 piece tape & reel prototype quantities, contact MPS. (The order code for 500 piece partial reel is “-P”, and the tape & reel dimensions same as the full reel.)



REVISION HISTORY

| Revision # | Revision Date | Description | Pages Updated |
|------------|---------------|-----------------|---------------|
| 1.0 | 1/13/2022 | Initial Release | - |

Notice: The information in this document is subject to change without notice. Please contact MPS for current specifications. Users should warrant and guarantee that third-party Intellectual Property rights are not infringed upon when integrating MPS products into any application. MPS will not assume any legal responsibility for any said applications.

Mouser Electronics

Authorized Distributor

Click to View Pricing, Inventory, Delivery & Lifecycle Information:

[Monolithic Power Systems \(MPS\):](#)

[MPQ4436BGRE-Z](#) [MPQ4436BGRE-AEC1-P](#) [MPQ4436BGRE-AEC1-Z](#) [MPQ4436BGRE-P](#)