

Compact, intelligent sensors featuring MEMS technology for precision mass airflow measurement

- Precision unidirectional mass airflow up to 3 LPM
- Stable output across full scale
- Ultra-compact size 36.6 (L) x 8 (W) x 16.8 (H) mm
- Low power consumption



iSensors

Application Examples

- Pick and place systems
- Industrial processes
- Oxygen concentrators / conservators
- Leak detection
- Spectroscopy
- Mass flow controllers
- Scientific / test equipment
- Environmental comfort controls
- Fuel cell controls

Ordering Information

Model	Case	Applicable Gas	Flow Range	Notes
D6F -03A3-000	Thermoplastic resin/Aluminium Alloy	Air*	0-3LPM	-
D6F-CABLE 2				Optional recommended

*Dry gas must not contain large particles, eg. dust, oil, mist.

Rating

Absolute maximum rating

Item	Term	Ratings	Unit
Power-supply voltage	V _{CC}	26.4	VDC
Output voltage	V _{OUT}	6	VDC

Electrical Performance

Recommended operation condition and DC characteristic

Item	Term	Condition	MIN	TYP	MAX	Unit
Power-supply voltage	V _{CC}	-	10.8	-	26.4	VDC
Operating temperature	T _{OPR}	-	0	-	50	°C
Maximum output voltage	V _{OH}	V _{CC} = 12VDC to 24VDC I _{OH} = 0.5mA	5	-	5.7	VDC
Minimum output voltage	V _{OL}	V _{CC} = 12VDC to 24VDC I _{OL} = -0.5mA	0	-	1	VDC

■ Basic Performance

0 to 3L/min (Normal) volumetric flow rate at 0°C, 101.3kPa.

Measurement condition: Power-supply voltage 12±0.1VDC, ambient temperature 25±5°C and ambient humidity 25 to 75% RH.

D6F-03A3-000

Flow Rate L/min (normal)	0	0.6	1.2	1.8	2.4	3.0
Output Voltage (VDC)	1.00 ±0.2	2.83 ±0.2	3.77 ±0.2	4.34 ±0.2	4.72 ±0.2	5.00 ±0.2

■ Characteristics

Degree of Protection	IP40
Applicable Gas	Air
Electrical Connection	Connector (3 wire)
Output Signal	Analogue, 1-5VDC (load resistance 10kΩ min)
Current Consumption	Max 15mA (no load, V _{CC} = 12 to 24VDC, V _{SS} = GND = 0V, 25°C)
Repeat Accuracy	±5% FSD max, 25°C
Insulation Resistance	20Mohm min. (500VDC between lead terminals and case)
Dielectric Strength	500VAC, 50/60Hz for 1 minute (leakage current typ. <1mA) between lead terminals and case
Withstand Pressure	200 kPa
Operating Temperature	0 to 50°C (with no ice or dew condensation)
Operating Humidity	85%RH max. (with no ice or dew condensation)
Storage Temperature	-10 to 60°C (with no ice or dew condensation)
Storage Humidity	85%RH max. (with no ice or dew condensation)
Weight	5.27g

■ Precautions

1. Avoid use in excessively dirty, wet environments
2. Do not use in the presence of flammable gases (e.g. hydrogen, methane, ethane and liquefied petroleum gas. In addition, do not use with corrosive gases (eg chlorine, sulphur, acids, alkalis etc).
3. Install in the direction of the arrow indicated.
4. For best results (optimum accuracy), mount horizontally.
5. Use suitable M3 screws for mounting. Do not exceed a fixing torque of 0.59 Nm.
6. Do not modify D6F- in any way.
7. Do not place any object in or close to the inlet and outlet orifices.
8. Do not use the sensor in any of the following environments:
 - a location that receives radiant heat from the sun or apparatus
 - a place where intense light may radiate down
 - where fast changing temperatures occur
 - locations prone to freezing, high humidity, condensation
 - places where large magnitudes of vibration or shock could occur
9. Noise countermeasures: VERY IMPORTANT. Take suitable precautions to minimise the effects and potential for induced electrical noise. Install away from apparatus that generates strong high frequencies, surges and spikes. Take particular care to install away from AC power transformers, live mains power lines and high power magnetic circuits. Attach a surge suppressor and a noise filter to the peripheral equipment.
10. Ensure good grounding is achieved by grounding the GND terminal to the peripheral equipments main ground frame connection and its associated regulated power supply.
11. Do not make a direct solder connection to the integral terminals. It is recommended you use the optional cable 'D6F-CABLE2' for attachment and to ensure correct connection.
12. D6F- is a precision component. Keep in original packaging and remove only when ready for installation. Damage may occur if subjected to excessive force (e.g. dropped or kicked). Any item suspected to be damaged should be discarded.
13. Immediately following installation, a qualified person should perform checks to ensure safe, satisfactory operation.

Dimensions

All dimensions are shown in millimetres.

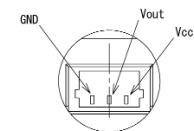

A (5 : 1)



Type name, Lot number

NITE1 Bind tight with 0.59N·m or less torque.

Use M3 pan head screw.

NOTE2 Use an attached connector.

The connector linked to this product should use the following JST Mfg. Co., Ltd.

Contact and an electric wire

• Disconnectable Insulation displacement Connectors
Receptacle : 03SR-3S

Wire : AWG#30

• Disconnectable Crimp Style Connectors

Contact : SSH-003T-P0.2

Wire : AWG#32~#28

Housing : SHR-03V-S-B or SHR-03V-S

NOTE3 Installation hole recommendation size.

2-M3 Screw hole

18 ±0.05

Connector
SM03B-SRSS-TB
Made by JST Mfg. Co., Ltd

A

2-M5 Depth 3.1 minimum

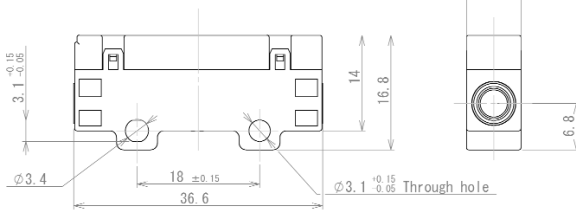

■ D6F- Cable2 (Optional)

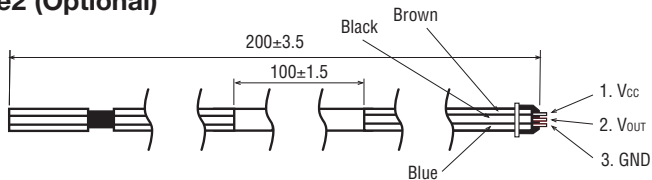

MEMS Mass Flow Sensor – D6F-03A3-000

No.	Name	Material
1	D6F	–
2	Polyethylene bag	Polyethylene
3	Box	Coated board paper
4	Label (Bar code)	–

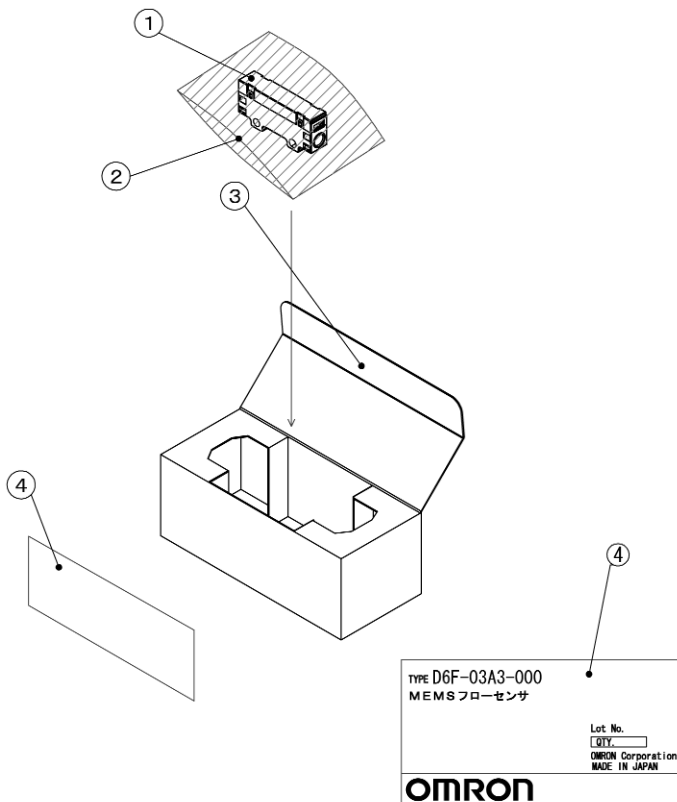

■ Warranty

Omron corporation manufactures products to the highest standards and warrants that all products it manufactures are free of defects and faulty workmanship.

Please contact your local Omron representative for warranty information.

Specifications subject to change without notice. Any information supplied is believed to be accurate and reliable at the time of printing.

We provide application assistance personally and through our literature including our website for guidance only. It is the customers full responsibility to determine suitability of product in any intended application.

ALL DIMENSIONS SHOWN ARE IN MILLIMETERS.

To convert millimeters into inches, multiply by 0.03937. To convert grams into ounces, multiply by 0.03527.