

IM68A130V01

High performance analog XENSIV™ MEMS microphone

Features

- Surface mount package: 3.35mm x 2.5mm x 0.98mm
- Analog single-ended output
- Flat frequency response with low-frequency roll-off at 10Hz
- Acoustic overload point at 130dB SPL
- Signal-to-noise ratio of 68dB(A) SNR
- Narrow sensitivity and phase tolerances
- Omnidirectional pickup pattern



Potential applications

- Active Noise Cancellation (ANC) headphones and earphones
- Smartphones and mobile devices
- Devices with Voice User Interface (VUI)
 - Smart speakers
 - Home automation
 - IOT devices
- High quality audio capturing
 - Laptops and tablets
 - Conference systems
 - Cameras and camcorders
- Industrial or home monitoring with audio pattern detection

Product validation

Technology qualified for industrial applications.

Ready for validation in industrial applications according to the relevant tests of IEC 60747 and 60749 or alternatively JEDEC47/20/22.

Description

The IM68A130V01 is a high performance, single-ended, analog MEMS microphone designed for applications which require a low LFRO (10Hz), a high SNR (low self-noise), and low distortion (high AOP).

The high signal-to-noise ratio (SNR) of 68dB(A) enables far field and low volume audio pick-up. The flat frequency response and tight manufacturing tolerance improve the performance of Active Noise Cancellation (ANC) and multi-microphone array applications.

The high performance analog microphone ASIC contains an extremely low noise preamplifier providing constant current consumption (110µA) over VDD.

Each IM68A130V01 microphone is calibrated with an advanced Infineon calibration algorithm, resulting in small sensitivity tolerances (± 1 dB).

Type	Package	Marking
IM68A130V01	PG-TLGA-4-2	I68A04

Table of contents

	Features	1
	Potential applications	1
	Product validation	1
	Description	1
	Table of contents	2
1	Block diagram reference	3
2	Typical microphone interface	3
3	Typical performance characteristics	4
4	Acoustic characteristics	6
4.1	Free field frequency response	7
5	Electrical characteristics and parameters	8
5.1	Absolute maximum ratings	8
5.2	Electrical parameters	8
5.3	Electrical characteristics	8
6	Package information	9
7	Footprint and stencil recommendation	10
8	Packing information	11
9	Reflow soldering and board assembly	12
10	Reliability specifications	14
	Revision history	15
	Disclaimer	16

1 Block diagram reference

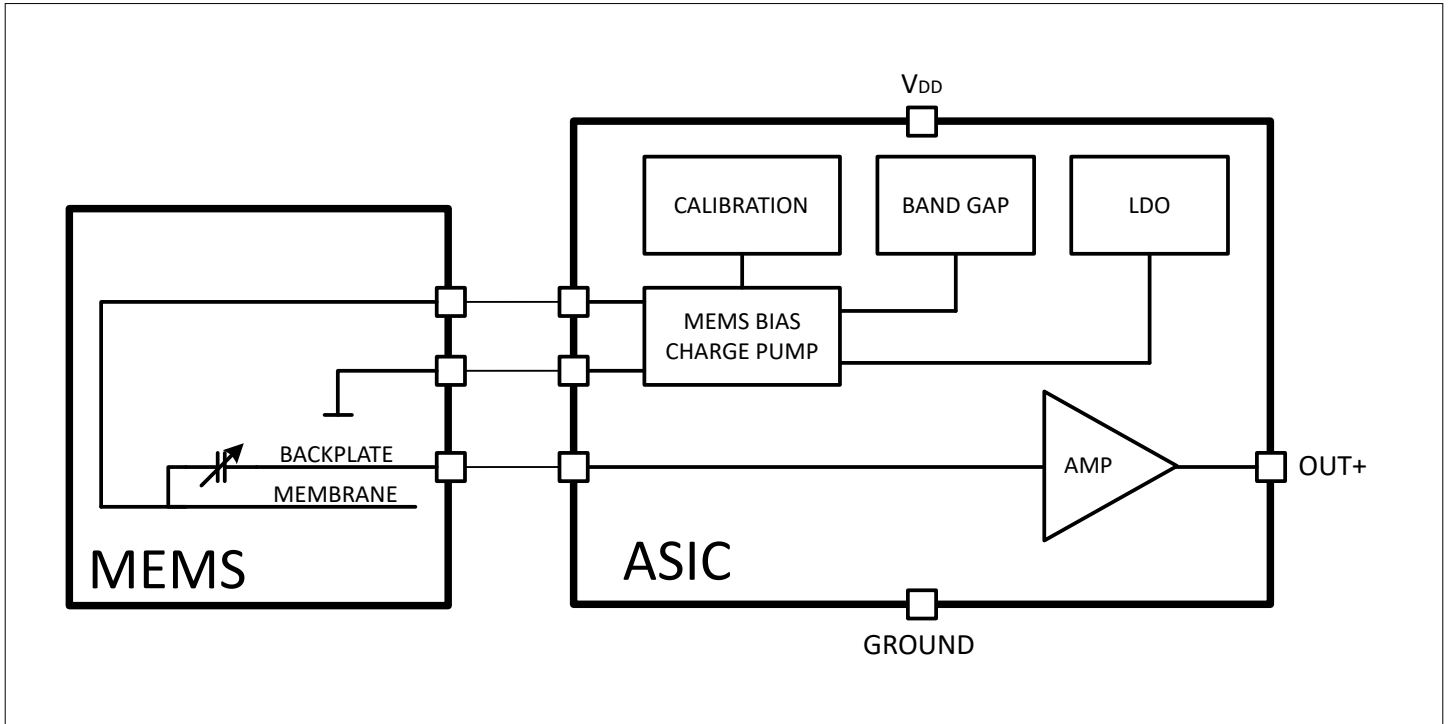

Figure 1 Block diagram

2 Typical microphone interface

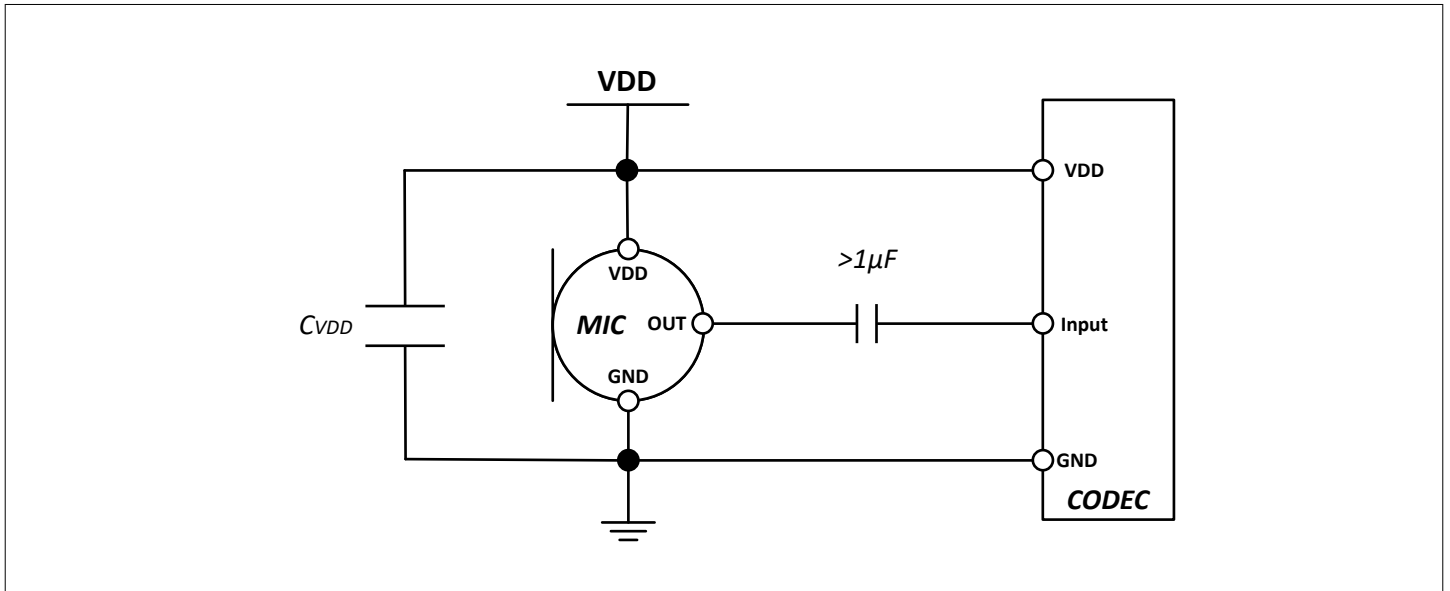

Figure 2 Single ended analog microphone interface example

Note: Power supply filtering capacitors should be placed physically as close to the microphone as possible. Detailed information on electrical, acoustical, and mechanical implementation can be found in the application note on XENSIV™ MEMS microphone [web page](#)

3 Typical performance characteristics

Test conditions (unless otherwise specified): $V_{DD} = 2.75V$, $T_A = 25^\circ C$, output unloaded

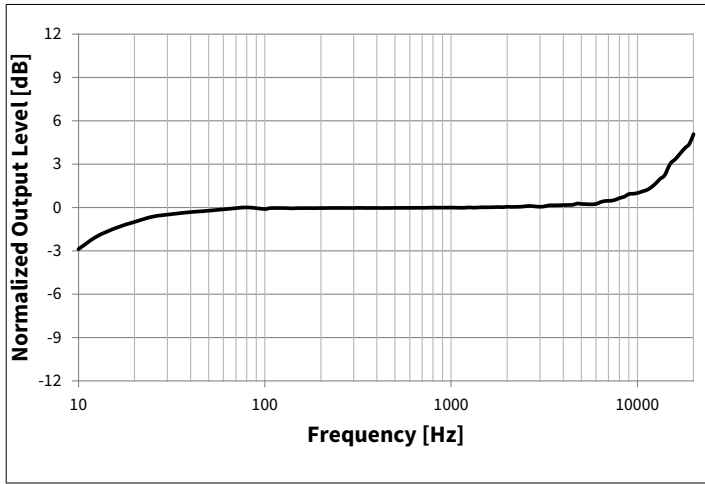

Figure 3 Typical amplitude response

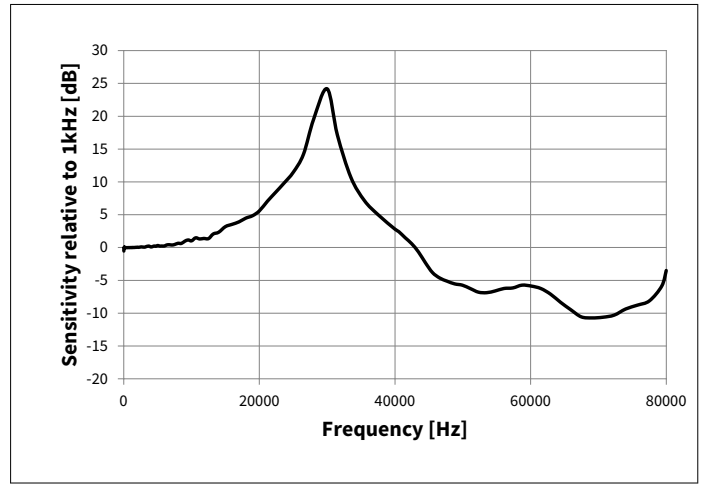

Figure 4 Typical ultrasonic response

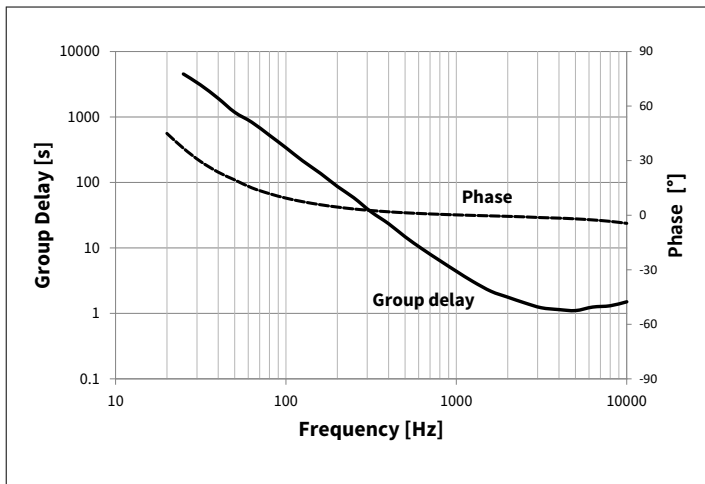

Figure 5 Typical group delay and phase response

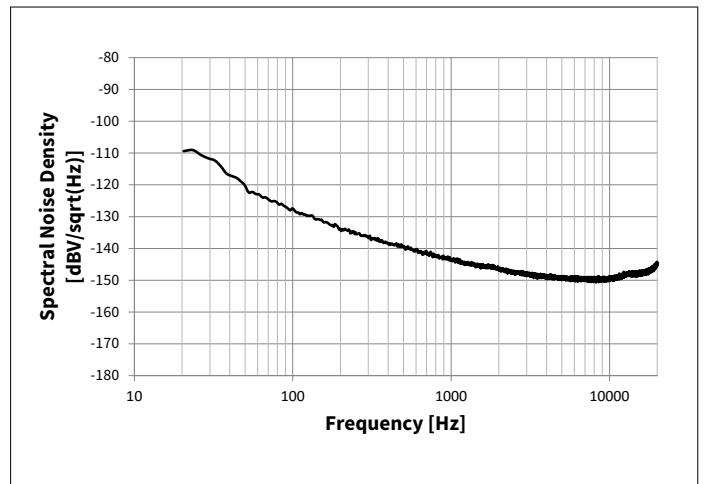

Figure 6 Typical noise floor (unweighted)

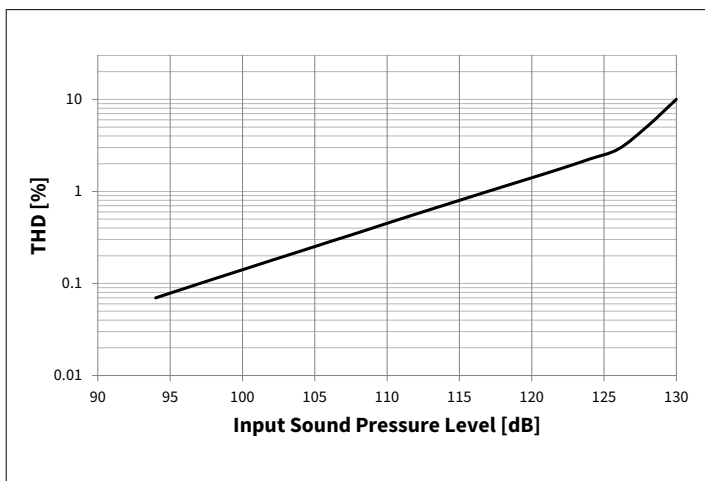

Figure 7 Typical THD vs SPL

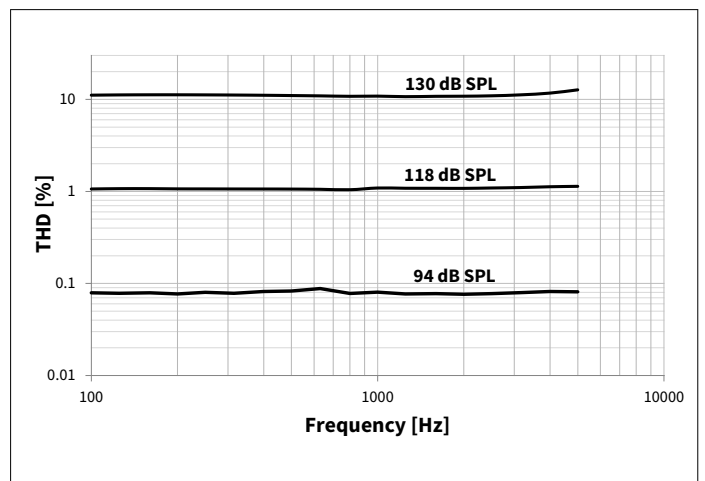

Figure 8 Typical THD vs frequency

3 Typical performance characteristics

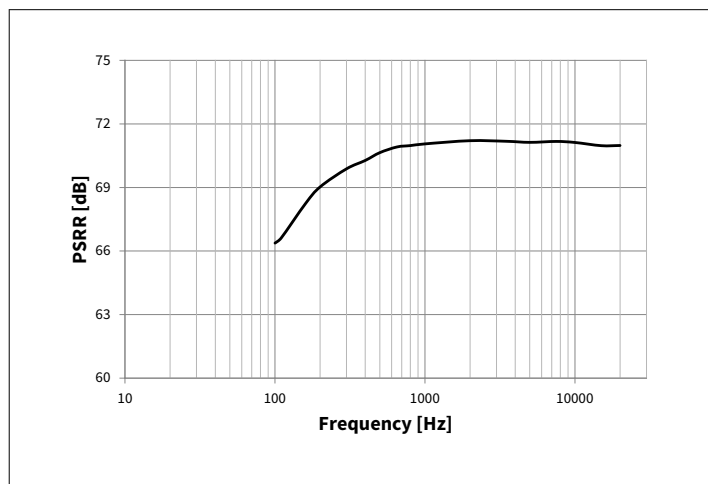

Figure 9 Typical PSRR

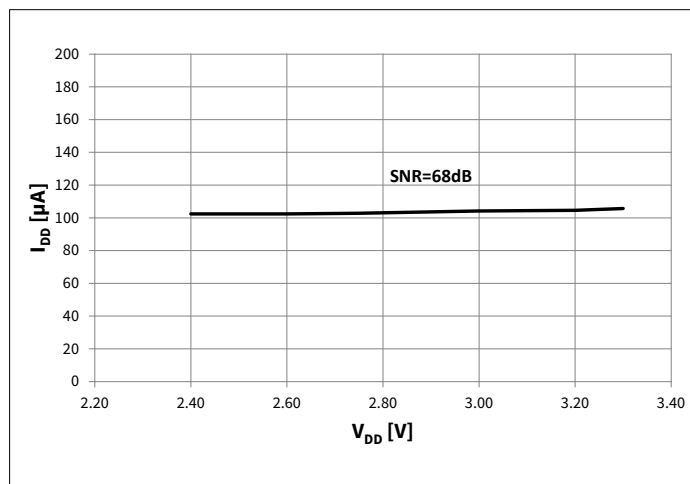

Figure 10 Typical I_{DD} vs V_{DD}

4 Acoustic characteristics

Test conditions (unless otherwise specified in the table): $V_{DD} = 2.75V$, $T_A = 23^{\circ}C \pm 5^{\circ}C$, 55% R.H., audio bandwidth 20Hz to 20kHz, output unloaded.

Table 1 IM68A130V01 acoustic specifications

Parameter	Symbol	Values			Unit	Note or Test Condition
		Min.	Typ.	Max.		
Sensitivity	S	-39	-38	-37	dBV/Pa	1kHz, 94 dB SPL
Sensitivity stability over V_{DD}		-0.5		+0.5	dB	
Signal-to-noise ratio	SNR		68		dB(A)	A-Weighted
Low-frequency roll-off	LFRO		10		Hz	-3dB relative to 1kHz sensitivity
High frequency flatness			15		kHz	+3dB relative to 1kHz sensitivity
Resonant frequency peak	Fres		30		kHz	
Total harmonic distortion	94dB SPL	THD			%	Measuring 2nd to 5th harmonics, 1kHz
	118dB SPL			1		
Acoustic overload point	10 % THD	AOP		130		
Phase response	250Hz			2.5	°	
	1kHz			-0.5		
	4kHz			-2.0		
Group delay	250Hz			45	μs	
	1kHz			3.0		
	4kHz			1.0		
Directivity			Omnidirectional			Pickup pattern
Polarity			Increasing output voltage			Increasing sound pressure level

4.1 Free field frequency response

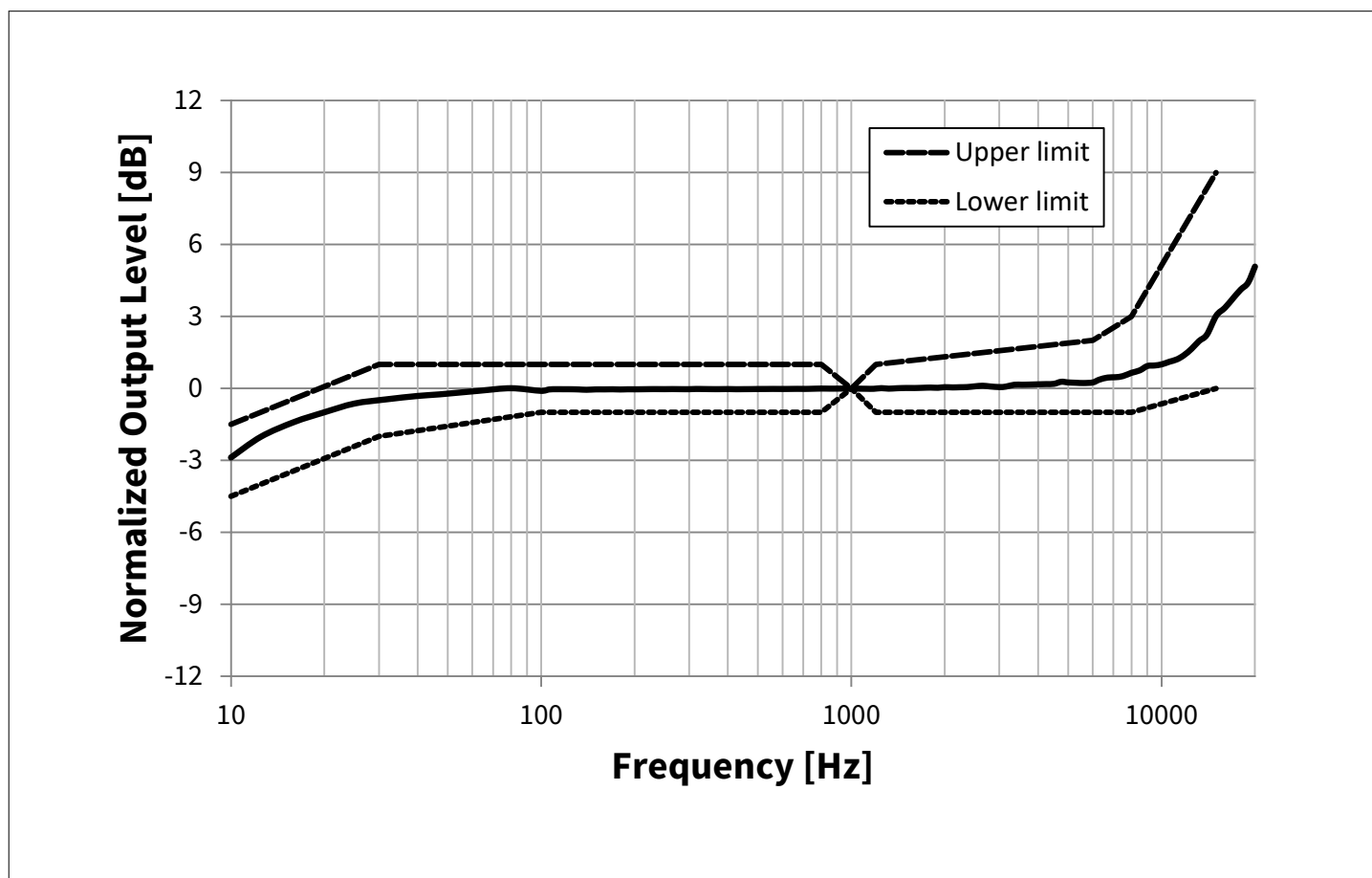

Figure 11 1 free field frequency response TBD

Table 2 free field frequency response, normalized to 1kHz sensitivity value

Frequency [Hz]	Upper limit [dB]	Lower limit [dB]
10	-1.5	-4.5
100	-1.5	0.5
800	-1	1
1000	0	0
1200	-1	1
6000	-1	1.5
10000	-1	2
15000	-0.5	3

5 Electrical characteristics and parameters

5.1 Absolute maximum ratings

Stresses exceeding the listed maximum ratings may affect device reliability or cause permanent device damage. Functional device operation at these conditions is not guaranteed.

Table 3 Absolute maximum ratings

Parameter	Symbol	Values		Unit	Note / Test Condition
		Min.	Max.		
Supply voltage	V_{DDmax}		3.6	V	
Storage temperature	T_S	-40	100	°C	
Operating temperature	T_A	-40	85	°C	

5.2 Electrical parameters

Table 4 IM68A130V01 electrical parameters

Parameter	Symbol	Values			Unit	Note / Test Condition
		Min.	Typ.	Max.		
Supply voltage	VDD	2.4	2.75	3.3	V	¹⁾
Output load	C_{load}			150	pF	DC-coupled
	R_{load}			10	MΩ	AC-coupled

5.3 Electrical characteristics

Test conditions (unless otherwise specified in the table): $V_{DD} = 2.75V$, $T_A = 23°C \pm 5°C$, 55% R.H.

Table 5 IM68A130V01 electrical characteristics

Parameter	Symbol	Values			Unit	Note / Test Condition
		Min.	Typ.	Max.		
Current consumption	I_{DD}		110	135	μA	Input ≤ 94 dB SPL
Startup current consumption	$I_{DD_STARTUP}$			1	μA	Current peak during startup process
Startup time	$t_{startup}$			10	ms	Time from application of supply until functionality is given
Vout DC-voltage	V_{OUT_DC}		1.3		V	
Power supply rejection ratio	PSRR		71		dB	1 kHz sine wave of 200 mV _{pp}
Output Impedance	Z_{out}			400	Ω	@ 1kHz

¹⁾ A 100nF bypass capacitor should be placed close to the microphone V_{DD} pin to ensure best SNR performance

6 Package information

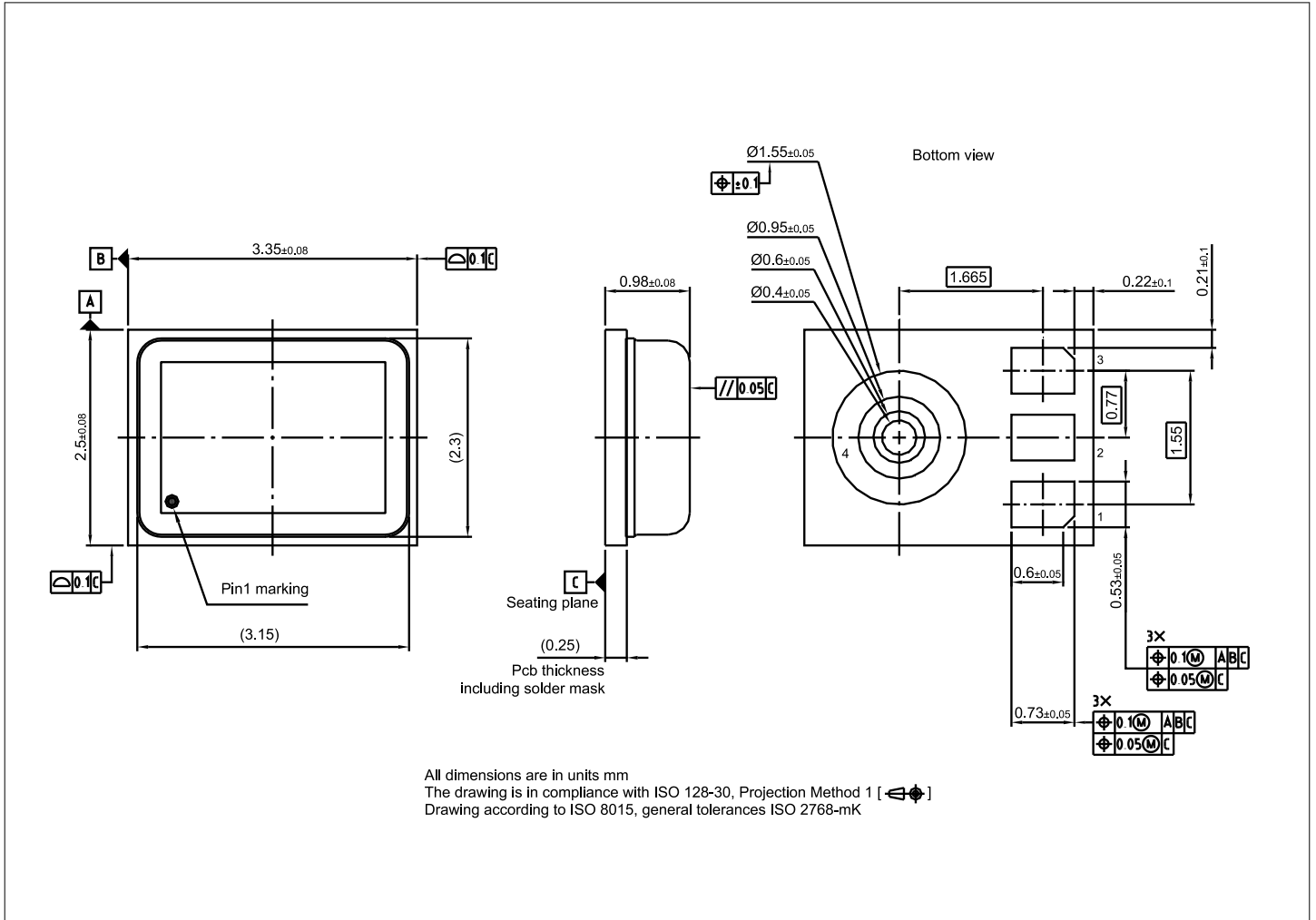

Figure 12 IM68A130V01 package drawing

Table 6 IM68A130V01 pin configuration

Pin Number	Name	Description
1	Output	Microphone output
2	GND	Ground
3	V _{DD}	Power supply
4	GND	Ground

7 Footprint and stencil recommendation

The acoustic port hole diameter in the PCB should be larger than the acoustic port hole diameter of the MEMS microphone to ensure optimal performance. A PCB sound port size of diameter 0.6 mm is recommended.

The board pad and stencil aperture recommendations shown in [Figure 13](#) are based on Solder Mask Defined (SMD) pads. The specific design rules of the board manufacturer should be considered for individual design optimizations or adaptations.

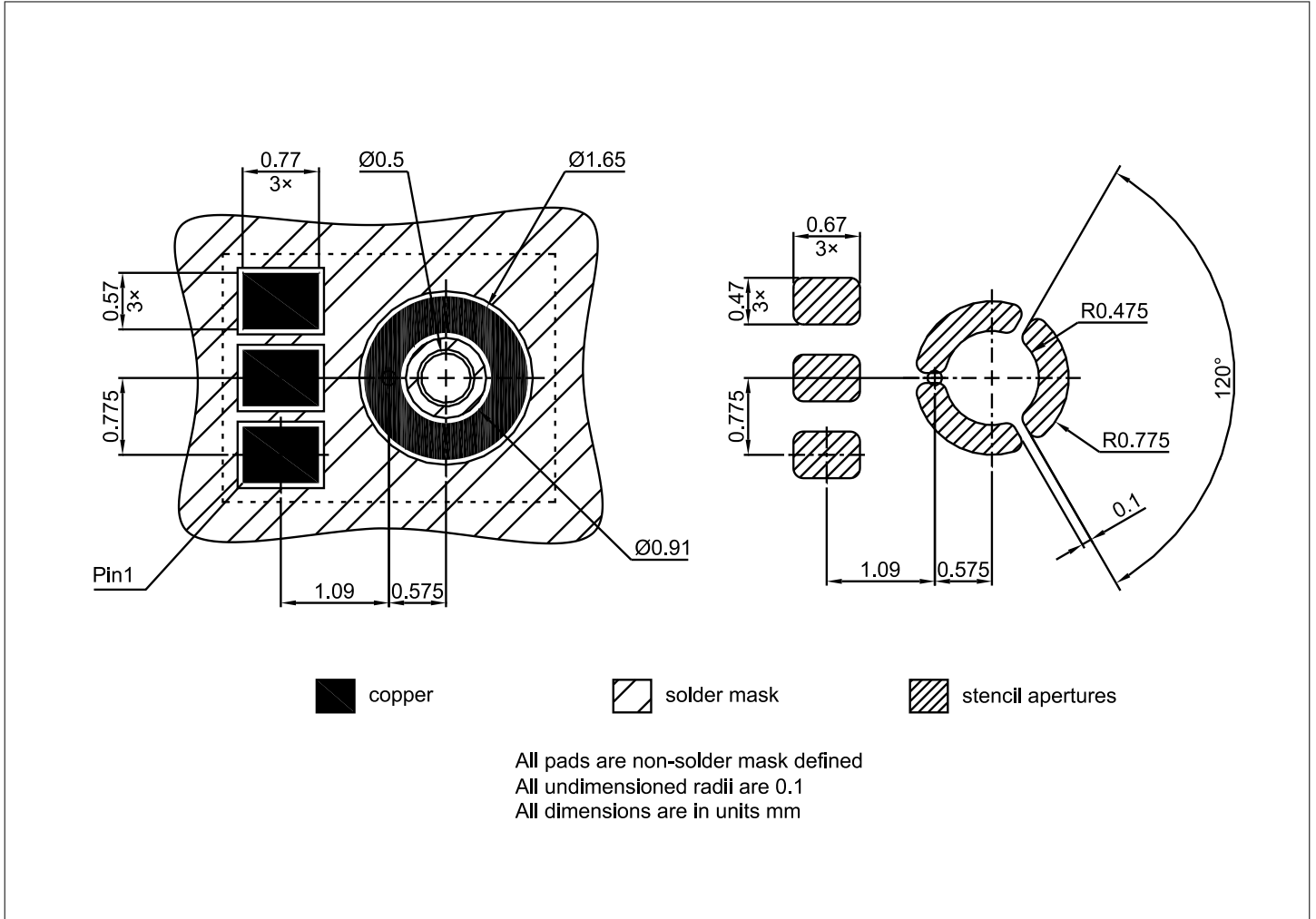

Figure 13 Footprint and stencil recommendation

8 Packing information

For shipping and assembly the Infineon microphones are packed in product specific tape-and-reel carriers. A detailed drawing of the carrier can be seen in [Figure 14](#)

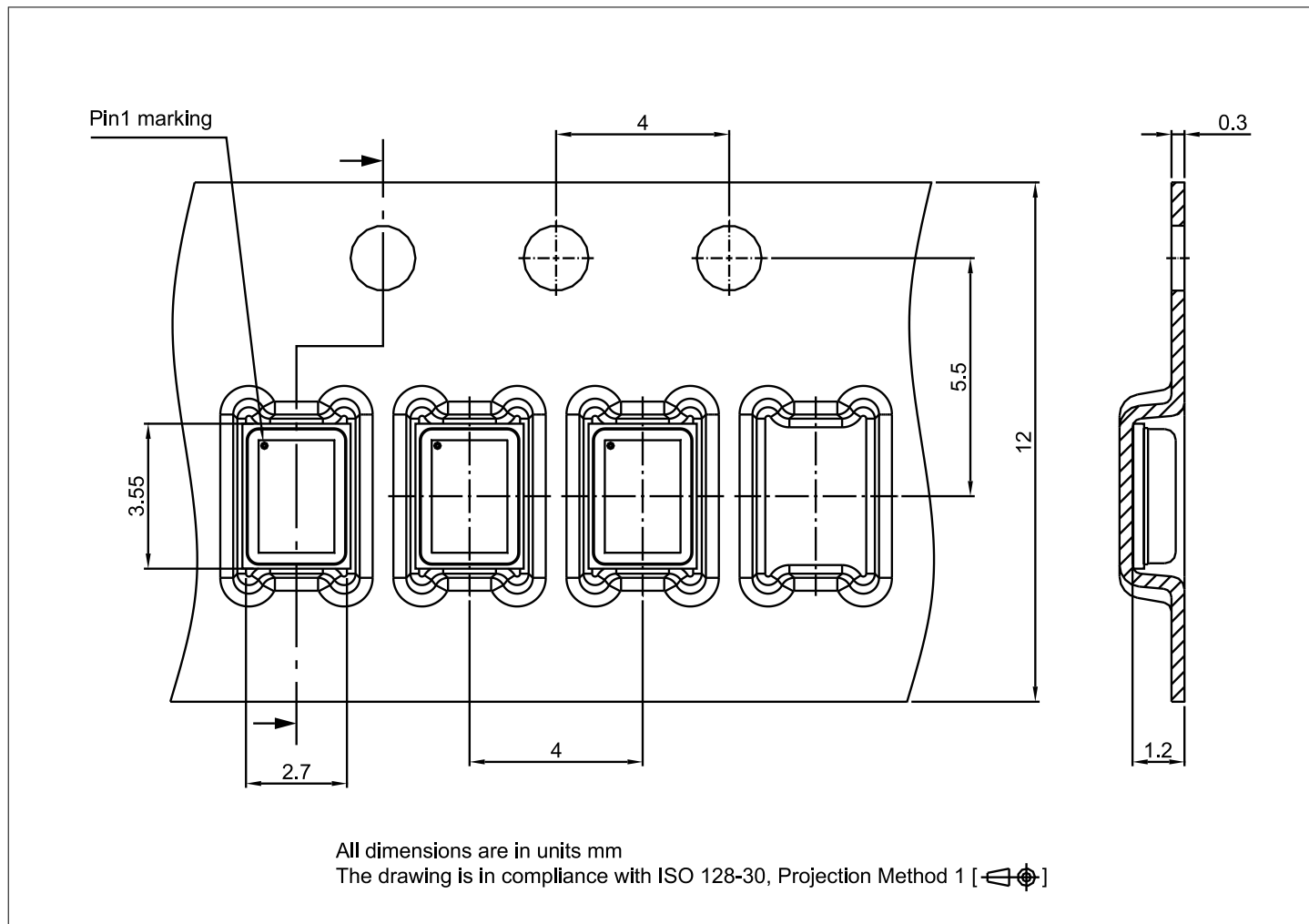

Figure 14 IM68A130V01 tape and reel packing information

Table 7 IM68A130V01 packaging information

Product	Type code	Reel diameter	Quantity per reel
IM68A130V01	I68A04	13"	5000

9 Reflow soldering and board assembly

Infineon MEMS microphones are qualified in accordance with the IPC/JEDEC J-STD-020D-01. The moisture sensitivity level of MEMS microphones is rated as MSL1. For PCB assembly of the MEMS microphone the widely used reflow soldering using a forced convection oven is recommended.

The soldering profile should be in accordance with the recommendations of the solder paste manufacturer to reach an optimal solder joint quality. The reflow profile shown in Figure 15 is recommended for board manufacturing with Infineon MEMS microphones.

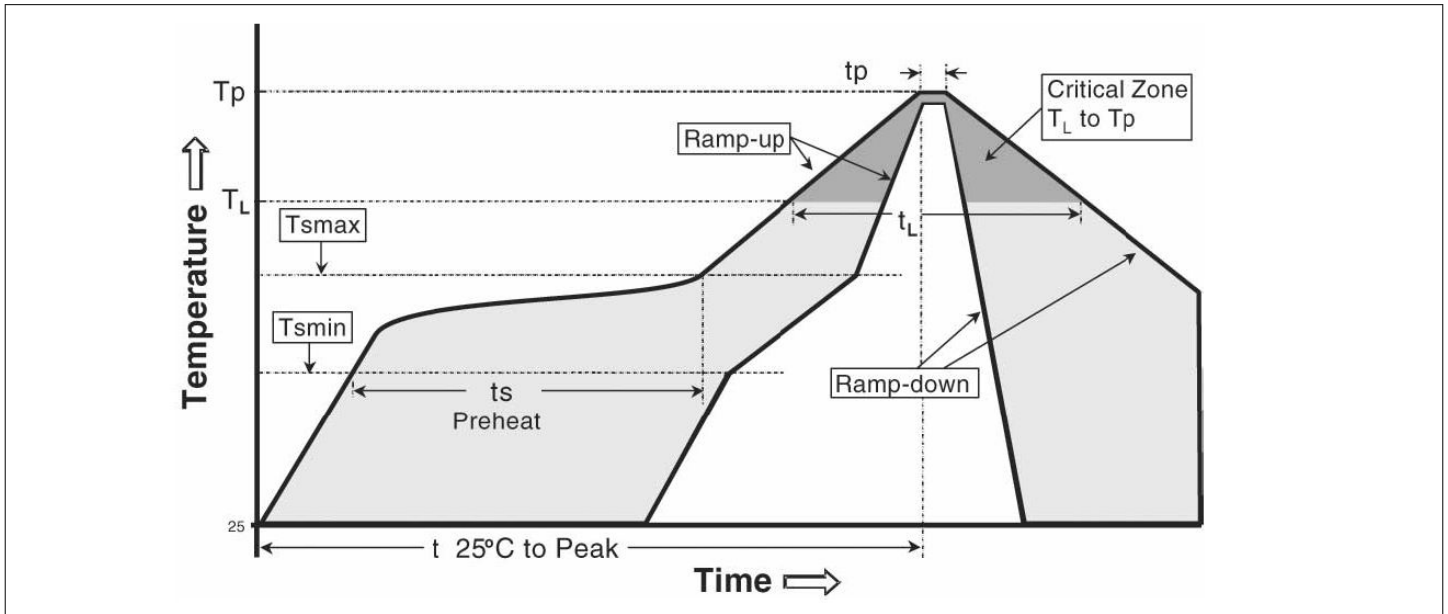

Figure 15 Recommended reflow profile

Table 8 Reflow profile limits

Profile feature	Pb-Free assembly	Sn-Pb Eutectic assembly
Temperature Min (T_{smin})	150 °C	100 °C
Temperature Max (T_{smax})	200 °C	150 °C
Time (T_{smin} to T_{smax}) (t_s)	60-120 seconds	60-120 seconds
Ramp-up rate (T_L to T_p)	3 °C/second max.	3 °C/second max.
Liquidous temperature (T_L)	217 °C	183 °C
Time (t_L) maintained above T_L	60-150 seconds	60-150 seconds
Peak Temperature (T_p)	260°C +0°C/-5°C	235°C +0°C/-5°C
Time within 5°C of actual peak temperature (t_p) ²⁾	20-40 seconds	10-30 seconds
Ramp-down rate	6 °C/second max.	6 °C/second max.
Time 25°C to peak temperature	8 minutes max.	6 minutes max.

Note: For further information please consult the 'General recommendation for assembly of Infineon packages' document which is available on the Infineon Technologies [web page](#)

²⁾ Tolerance for peak profile temperature (T_p) is defined as a supplier minimum and a user maximum

The MEMS microphones can be handled using industry standard pick and place equipment. Care should be taken to avoid damage to the microphone structure as follows:

- Do not pick the microphone with vacuum tools which make contact with the microphone acoustic port hole.
- The microphone acoustic port hole should not be exposed to vacuum, this can destroy or damage the MEMS.
- Do not blow air into the microphone acoustic port hole. If an air blow cleaning process is used, the port hole must be sealed to prevent particle contamination.
- It is recommended to perform the PCB assembly in a clean room environment in order to avoid microphone contamination.
- Air blow and ultrasonic cleaning procedures shall not be applied to MEMS Microphones. A no-clean paste is recommended for the assembly to avoid subsequent cleaning steps. The microphone MEMS can be severely damaged by cleaning substances.
- To prevent the blocking or partial blocking of the sound port during PCB assembly, it is recommended to cover the sound port with protective tape during PCB sawing or system assembly.
- Do not use excessive force to place the microphone on the PCB. The use of industry standard pick and place tools is recommended in order to limit the mechanical force exerted on the package.

10 Reliability specifications

The microphone sensitivity after stress must deviate by no more than 3dB from the initial value.

Table 9 Reliability specification

Test	Abbreviation	Test Condition	Standard
Low Temperature Operating Life	LTOL	T _a =-40°C, VDD=3.6V, 1000 hours	JESD22-A108
Low Temperature Storage Life	LTSL	T _a =-40°C, 1000 hours	JESD22-A119
High Temperature Operation Life	HTOL	T _a =+125°C, VDD=3.6V, 1000 hours	JESD22-A108
High Temperature Storage Life	HTSL	T _a =+125°C, 1000 hours	JESD22-A103
Temperature Cycling	PC + TC	Pre conditioning MSL-1	JESD22-A113
		1000 cycles, -40°C to +125°C, 30 minutes per cycle	JESD22-A104
Temperature Humidity Bias	PC + THB	Pre conditioning MSL-1	JESD22-A113
		T _a =+85°C, R.H. = 85%, VDD=3.6V, 1000 hours	JESD22-A101
Vibration Test	VVF	20Hz to 2000Hz with a peak acceleration of 20g in X, Y, and Z for 4 minutes each, total 4 -cycles	IEC 60068-2-6
Mechanical Shock	MS	10000g/0.1msec direction ±x,y,z, 5 shocks in each direction, 5 shocks in total	IEC 60068-2-27
Reflow Solder ³⁾	RS	3 reflow cycles, peak temperature = +260°C	IPC-JEDEC J-STD-020D-01
Electrostatic Discharge -System Level Test	ESD - SLT	3 discharges of ±8kV direct contact to lid while V _{dd} is supplied according to the operational modes; (V _{dd} ground is separated from earth ground)	IEC-61000-4-2
Electrostatic Discharge - Human Body Model	ESD - HBM	1 pulse of ±2kV between all I/O pin combinations	JEDEC-JS001
Electrostatic Discharge - Charged Device Model	ESD - CDM	3 discharges of ±500V direct contact to I/O pins.	JEDEC JS-002

³⁾ The microphone sensitivity must deviate by no more than 1dB from the initial value after 3 reflow cycles.

Revision history

Document version	Date of release	Description of changes
v01.00	2022-12-02	<ul style="list-style-type: none">Initial release

Trademarks

All referenced product or service names and trademarks are the property of their respective owners.

Edition 2022-12-02

Published by

Infineon Technologies AG

81726 Munich, Germany

© 2022 Infineon Technologies AG

All Rights Reserved.

Do you have a question about any aspect of this document?

Email: erratum@infineon.com

Document reference

IFX-fbm1652085915221

Important notice

The information given in this document shall in no event be regarded as a guarantee of conditions or characteristics ("Beschaffheitsgarantie").

With respect to any examples, hints or any typical values stated herein and/or any information regarding the application of the product, Infineon Technologies hereby disclaims any and all warranties and liabilities of any kind, including without limitation warranties of non-infringement of intellectual property rights of any third party.

In addition, any information given in this document is subject to customer's compliance with its obligations stated in this document and any applicable legal requirements, norms and standards concerning customer's products and any use of the product of Infineon Technologies in customer's applications.

The data contained in this document is exclusively intended for technically trained staff. It is the responsibility of customer's technical departments to evaluate the suitability of the product for the intended application and the completeness of the product information given in this document with respect to such application.

Warnings

Due to technical requirements products may contain dangerous substances. For information on the types in question please contact your nearest Infineon Technologies office.

Except as otherwise explicitly approved by Infineon Technologies in a written document signed by authorized representatives of Infineon Technologies, Infineon Technologies' products may not be used in any applications where a failure of the product or any consequences of the use thereof can reasonably be expected to result in personal injury.

Mouser Electronics

Authorized Distributor

Click to View Pricing, Inventory, Delivery & Lifecycle Information:

[Infineon:](#)

[IM68A130AXTMA1](#)