

THIS DRAWING IS UNPUBLISHED. RELEASED FOR PUBLICATION
 © COPYRIGHT - By - ALL RIGHTS RESERVED.

LOC	DIST	REVISIONS					
		P	LTR	DESCRIPTION	DATE	DWN	APVD
G	14						
			V1	REVISED PER ECO-11-004587	11MAR11	RK	HMR

AMP WIRE RANGE	Listed	LR7189 Certified
22-16 AWG SOLID OR STRANDED	22-16 AWG SOLID OR STRANDED	22-16 AWG SOLID OR STRANDED

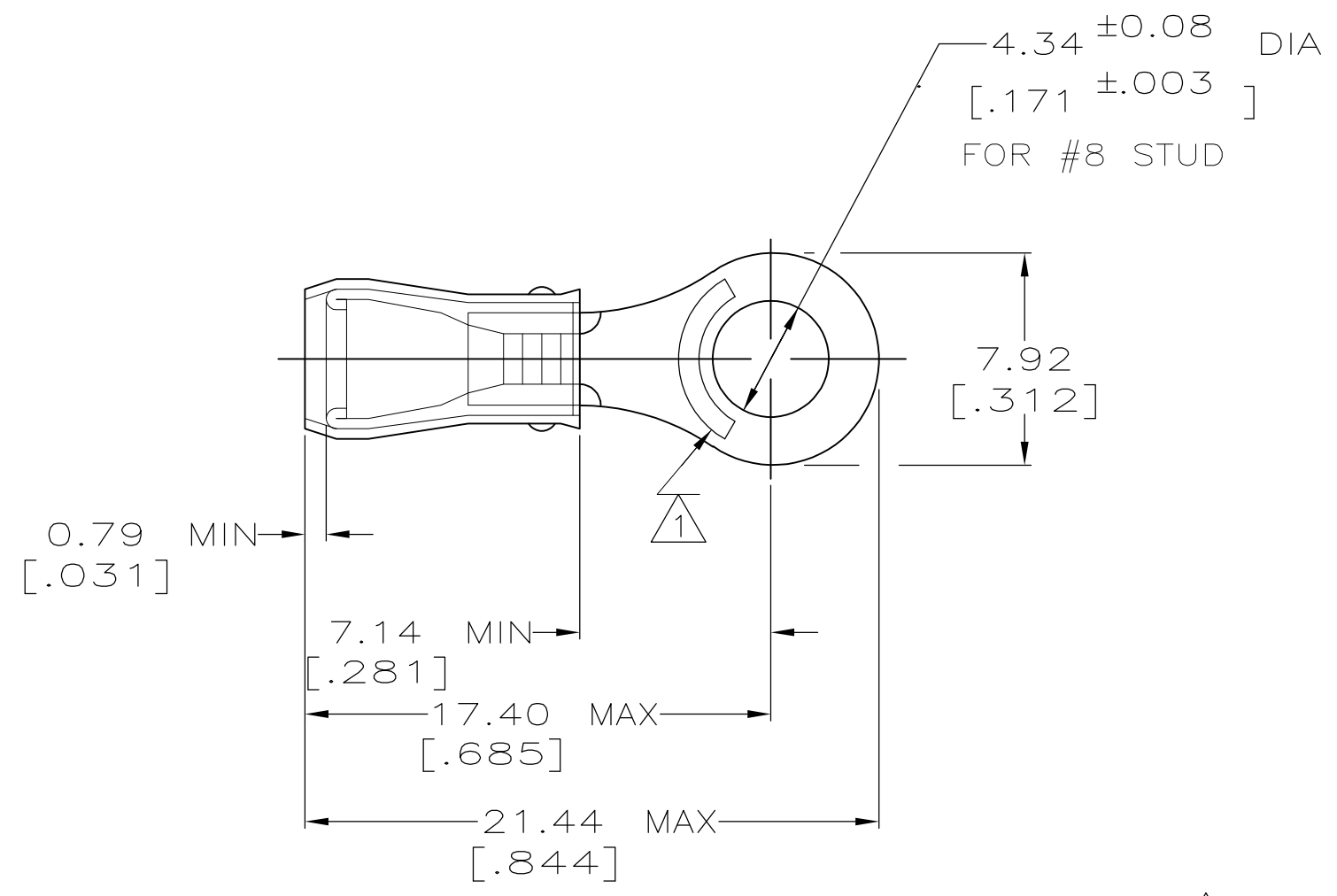

- 1 STAMP AMP 22-18* APPROX AS SHOWN
22-16 TERMINALS ARE STAMPED 22-18 IN
ACCORDANCE WITH MILITARY SPEC MIL-T-7928
COMMERCIAL WIRE RANGE IS 22-16
- 2 WIRE INSULATION DIA: .105 - .140
- 3 TONGUE MATERIAL THK: 0.79 ±0.05 [.031 ±.002]
- 4 SUPERSEDED BY 8-31890-1

MILITARY P/N AND CLASS	QUANTITY	PACKAGE TYPE	PART NO
-	50	LOOSE PIECE, BAG	8-31890-5
-	100	LOOSE PIECE, BOX	8-31890-1
MS 25036-149 CLASS 2	5000	ON TAPE, REEL	2-31890-1
MS 25036-149 CLASS 1 & 2	-	LOOSE PIECE	31890

AMP INCORPORATED
CUSTOMER SERVICE SYSTEMS

FOR ADDITIONAL PRODUCT INFORMATION OR COPIES OF DRAWINGS AND TECHNICAL DOCUMENTS
 PRODUCT INFORMATION CENTER
 1-800-522-6752

FOR APPLICATION TOOLING INFORMATION
 TOOLING ASSISTANCE CENTER
 1-800-722-1111

FOR ORDER ENTRY
 1-800-526-5142

MAX RECOMMENDED OPERATING TEMPERATURE:
 105° C MAX

VOLTAGE RATING:
 300 V MAX

WIRE CROSS SECTIONAL AREA RANGE:
 0.26-1.65mm² [509-3,260] CIR MILS
 SOLID OR STRANDED

THIS DRAWING IS A CONTROLLED DOCUMENT.

DIMENSIONS: INCHES

TOLERANCES UNLESS OTHERWISE SPECIFIED:

0 PLC	± -
1 PLC	± -
2 PLC	± 0.20[.008]
3 PLC	± -
4 PLC	± -
ANGLES	± -

MATERIAL: COPPER PER ASTM B-152 SLEEVE, RED NYLON

FINISH: TIN PLATE PER ASTM B545

DWN DK SCHRUM 02/11/93
 CHK RE HERSEY 4/28/93
 APVD ML ELLIS 4/28/93

PRODUCT SPEC: UL 486A

APPLICATION SPEC: NOT AVAILABLE

WEIGHT: -

STE TE Connectivity

NAME: TERMINAL, RING TONGUE, PIDG™ WIRE SIZE, 22-16 AWG

SIZE: A3 CAGE CODE: 00779 DRAWING NO: C-31890 RESTRICTED TO: -

CUSTOMER DRAWING SCALE: 4:1 SHEET: 1 OF 1 REV: V1