

1

2

3

4

REV	ECN#	DESCRIPTION OF REVISION	DRAW BY DATE	CHECK BY DATE	APPROVE BY DATE
01			Lucas 05/15/14	Ray 05/15/14	Ray 05/15/14

Notes: (Unless Otherwise Specified)

- 1. Waterproof Rate: IP67.
- 2. Recommend Panel Thickness: 0.8 to 4.0 mm.
- 3. Recommend Torque: 19.0~20.0 Kgf-cm.
- 4. RoHS Compliant.

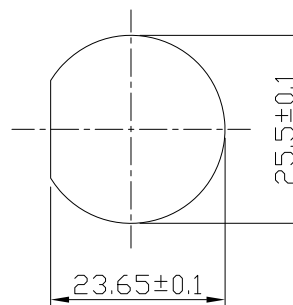
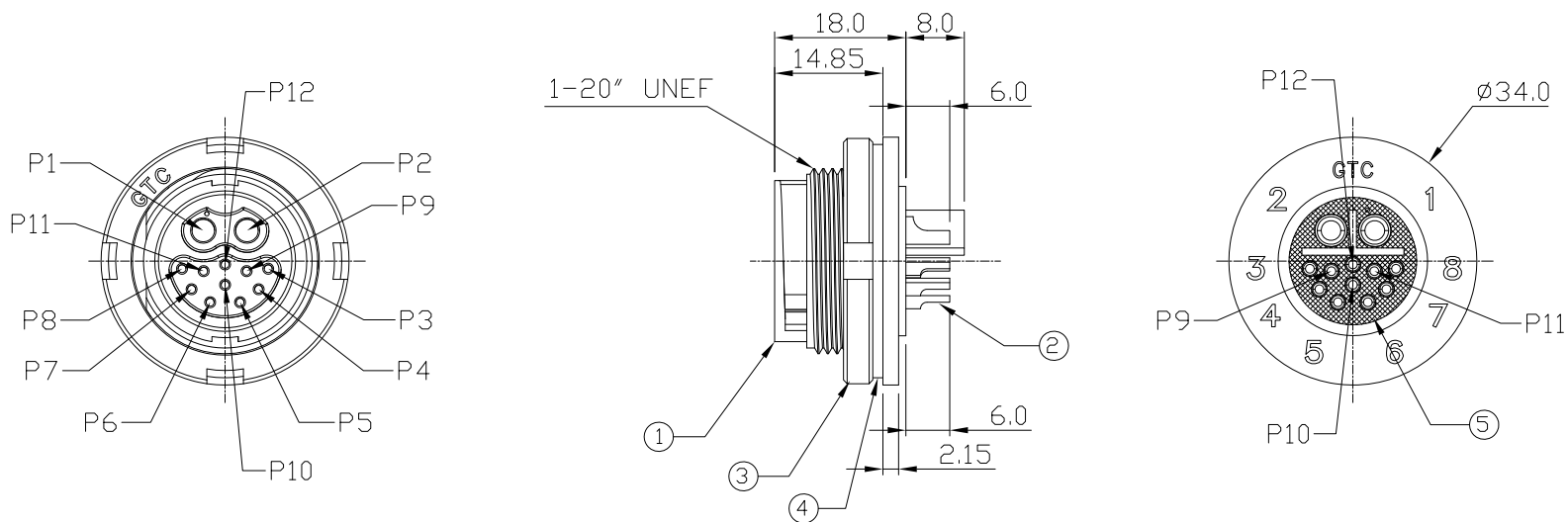

Recommend Panel Cut-Out

Item	Part Name	Material / Finish	Q'ty
5	Glue	Epoxy Color: Black	
4	Gasket	Silicone Color: Black	1
3	Spanner Nut	Thermoplastic Color: Black	1
2	Contacts	Copper Alloy Finish: Au Plated	12
1	Housing	Thermoplastic Color: Black	1

TITLE						Mating Part No.			REV.
C4 25A+5A 2P+10P Panel Female Solder Lock (Code A)						179-7947			01
THIRD ANGLE PROJECTION	SIZE	SCALE	DRAW / DATE	CHECK / DATE	APPROVE / DATE	TOLERANCES	UNIT	SHEET	
	B	1:1	Lucas 05/15/14	Ray 05/15/14	Ray 05/15/14	X.X ± 0.5 X.XX ± 0.2	mm	1/1	
						X.XXX ± 0.05 ANGLES ± 1°			

Part No.
179-7944
Cap:
179-7954



1

2

3

4