

SWITCH FUNCTION		
POS. 1	POS. 2	POS. 3
ON	NONE	ON
2-3, 5-6	N/A	2-1, 5-4

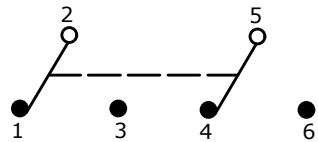

CIRCUIT: DPDT

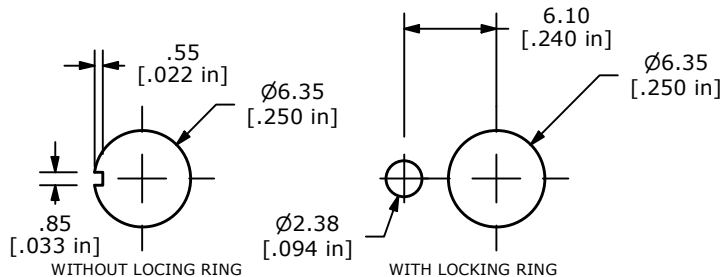
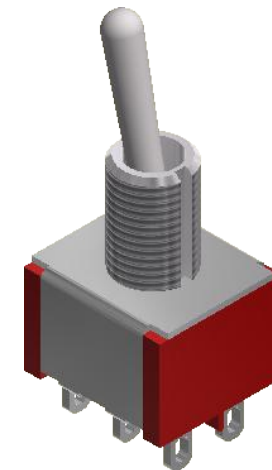
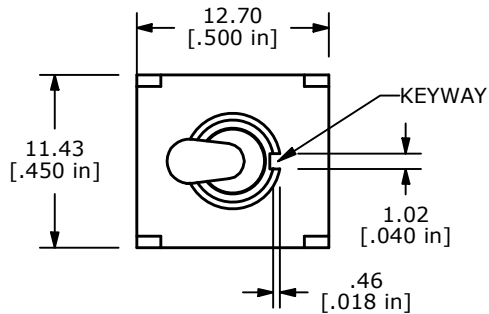

PANEL MOUNTING

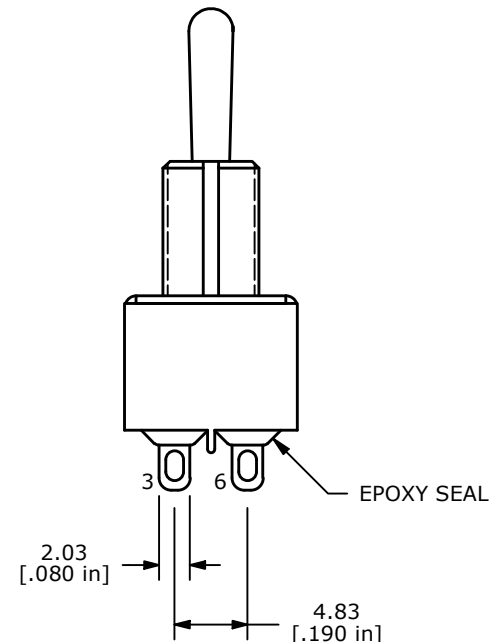
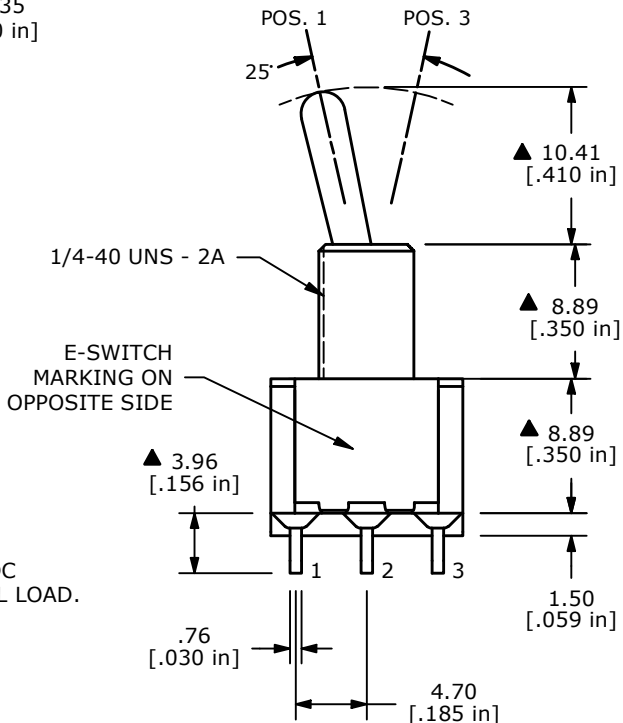

NOTE:

1. ALL DIMENSIONS IN MM [INCH]
2. GENERAL TOLERANCE: X.X=±0.4  
X.XX=±0.25
3. TERMINAL NUMBERS FOR REF ONLY
- ▲ 4. CONTACT MATERIAL: SILVER
5. CONTACT RATING: 2A @ 250VAC, 5A @ 120VAC OR 28 VDC
6. ELECTRIC LIFE: 40,000 MAKE-AND-BREAK CYCLES AT FULL LOAD.
7. CONTACT RESISTANCE: 10mΩ MAX. INITIAL @ 2-4VDC
8. INSULATION RESISTANCE: 1,000 MΩ MIN.
9. DIELECTRIC STRENGTH: 1,000 V RMS @SEA LEVEL.
10. OPERATING TEMP.: -30°C to 85°C
11. ▲ DENOTES CRITICAL PARAMETER.
12. 2002/95/EC (ROHS) COMPLIANT
- ▲ 13. HARDWARE TO BE SUPPLIED BULK:
 

T100011 - LOCK WASHER	QTY - 1
T100015 - LOCK RING	QTY - 1
T100000 - HEX NUT	QTY - 2



OBJECT ID  
000023101

B	20170	REVISED AND REDRAWN	9/21/11	BGL
REV	PCR NO	DESCRIPTION	DATE	BY

TITLE 100DP1T1B1M1QEH				
SCALE	DATE	DR	DWG	REV
2:1	9/21/2011	BGL	ST121005	B

THE INFORMATION CONTAINED IN THIS DOCUMENT IS PROPRIETARY TO E-SWITCH AND IS NOT TO BE COPIED OR TRANSFERRED