

MODEL CUB4L & CUB4L8 - MINIATURE ELECTRONIC COUNTERS



- LCD, POSITIVE REFLECTIVE OR NEGATIVE TRANSMISSIVE WITH YELLOW/GREEN OR RED LED BACKLIGHTING
- INTERNAL LITHIUM BATTERY PROVIDES UP TO 6 YEARS OF UNINTERRUPTED OPERATION
- NEMA 4X/IP65 SEALED FRONT BEZEL
- FRONT PANEL RESET, REMOTE RESET, OR BOTH
- COUNT SPEEDS UP TO 5 KHz
- WIRE CONNECTION MADE VIA SCREW CLAMP TYPE TERMINALS

DESCRIPTION

The CUB4 offers a large display in a miniature package with a choice of three displays; reflective, red backlight or green backlight.

The backlight versions require power from an external 9–28 VDC supply. The optional power supply (MLPS) is designed to be attached directly to the rear of the CUB4 and is powered from an 85–250 VAC source.

The CUB4 series has a lightweight, high impact plastic case with a clear viewing window. The sealed front panel with the silicone rubber reset button meets NEMA 4X/IP65 specifications for wash-down and/or dusty environments, when properly installed.

ORDERING INFORMATION

MODEL NO.	DESCRIPTION	PART NUMBERS
CUB4L (6-digit)	Counter Positive Image Reflective	CUB4L000
	Counter w/Yel-Grn Backlighting	CUB4L010
	Counter w/Red Backlighting	CUB4L020
CUB4L8 (8-digit)	Counter Positive Image Reflective	CUB4L800
	Counter w/Yel-Grn Backlighting	CUB4L810
	Counter w/Red Backlighting	CUB4L820
MLPS	+12 VDC Micro-Line Power Supply, 85 to 250 VAC source, 400 mA max out	MLPS1000
	+24 VDC Micro-Line Power Supply, 85 to 250 VAC source, 200 mA max out	MLPS2000

SAFETY SUMMARY

All safety related regulations, local codes and instructions that appear in the manual or on equipment must be observed to ensure personal safety and to prevent damage to either the instrument or equipment connected to it. If equipment is used in a manner not specified by the manufacturer, the protection provided by the equipment may be impaired.



CAUTION: Risk of Danger.
 Read complete instructions prior to installation and operation of the unit.

SPECIFICATIONS

- DISPLAY:**
 CUB4L: 6-Digit, LCD, 0.48" (12.2 mm) high digits.
 CUB4L8: 8-Digit, LCD, 0.46" (11.7 mm) high digits.
- POWER SOURCE:** Internal 3.6 V lithium battery will provide up to 6 years of continuous operation (high speed counting and extreme temperatures will decrease battery life).
- BACKLIGHT POWER REQUIREMENTS:** 9 to 28 VDC, 30 mA typical, 50 mA max. Above 26 VDC, derate operating temperature to 50°C. Must use an RLC model MLPS or an NEC Class 2 or Limited Power Source (LPS) rated power supply.
- COUNT INPUT:**
 SNK mode (DIP switch 1 off, internal pull-up to battery)
 V_{IN} High Min = 1.25 VDC; V_{IN} Low Max = 0.45 VDC
 I_{IN} Max = 5 μ A; V_{IN} Max = 3.6 VDC
 Count Speed: (count on negative edge)
 High freq mode (DIP switch 2 off): max 5 kHz @ 50% duty cycle
 Low freq mode (DIP switch 2 on): max 50 Hz @ 50% duty cycle
 SRC mode (DIP switch 1 on, internal 20 k Ω pull-down to common)
 V_{IN} High Min = 1.25 VDC; V_{IN} Low Max = 0.45 VDC
 I_{IN} Max = 5 mA; V_{IN} Max = 28 VDC
 Count Speed: (count on negative edge)
 High freq mode (DIP switch 2 off): max 5 kHz @ 50% duty cycle
 Low freq mode (DIP switch 2 on): max 50 Hz @ 50% duty cycle
- RESET INPUT:**
 V_{IN} Low Max = 1.5 VDC (internal pull-up to battery)
 I_{IN} Max = 20 μ A
 5 msec min (active low for count reset to zero)
- ENVIRONMENTAL CONDITIONS:**
Operating Temperature: 0 to 60°C (above 50°C, derate backlight operating voltage to 26 VDC max.).
Storage Temperature: -30 to 85°C
Operating and Storage Humidity: 85% max. (non-condensing) from 0°C to 50°C.
Vibration According to IEC 68-2-6: 5 to 500 Hz, in X, Y, Z direction for 1.5 hours, 5g.
Shock According to IEC 68-2-27: Operational 30 g, 11 msec in 3 directions.
Altitude: Up to 2000 meters

DIMENSIONS In inches (mm)

Note: Recommended minimum clearance (behind the panel) for mounting clip installation is 2.15" (54.6) H x 3.00" (76.2) W.

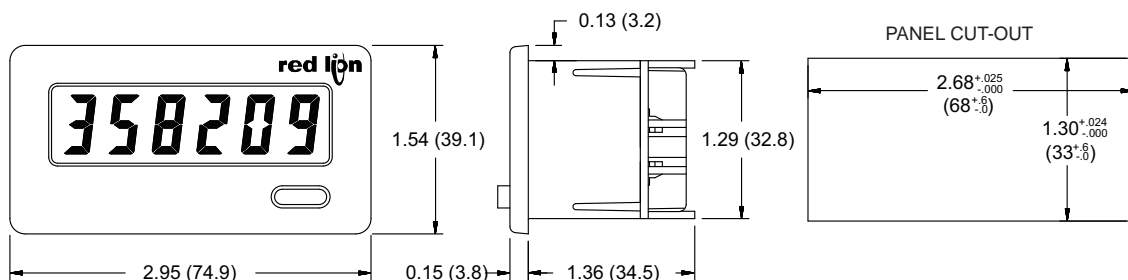

7. CERTIFICATIONS AND COMPLIANCES:

UL Recognized Component, File #E179259

SAFETY

IEC 61010-1, EN 61010-1: Safety requirements for electrical equipment for measurement, control, and laboratory use, Part 1.

IP65 Enclosure rating (Face only), IEC 529

Type 4X Indoor Enclosure rating (Face only), UL50

ELECTROMAGNETIC COMPATIBILITY

Emissions and Immunity to EN 61326:2006: Electrical Equipment for Measurement, Control and Laboratory use.

Immunity to Industrial Locations:

Electrostatic discharge	EN 61000-4-2	Criterion A 4 kV contact discharge 8 kV air discharge
Electromagnetic RF fields	EN 61000-4-3	Criterion A 10 V/m (80 MHz to 1 GHz) 3 V/m (1.4 GHz to 2 GHz) 1 V/m (2 GHz to 2.7 GHz)
Fast transients (burst)	EN 61000-4-4	Criterion A 2 kV power 1 kV I/O signal
Surge	EN 61000-4-5	Criterion A power 1 kV L to L, 2 kV L to G
RF conducted interference	EN 61000-4-6	Criterion A 3 Vrms
Power freq magnetic fields	EN 61000-4-8	Criterion A 30 A/m
AC power	EN 61000-4-11	Criterion A 0% during 1 cycle 40% during 10/12 cycle 70% during 25/30 cycle
Voltage dip		Criterion B 0% during 250/300 cycles
Short interruptions		Criterion B 0% during 250/300 cycles

Emissions:

Emissions EN 55011 Class B

Notes:

1. Criterion A: Normal operation within specified limits.
2. Criterion B: Temporary loss of performance from which the unit self-recovers.

Refer to the EMC Installation Guidelines section of the bulletin for additional information.

8. CONSTRUCTION:

This unit is rated for NEMA 4X/IP65 indoor use. Installation Category I, Pollution Degree 2

9. WEIGHT: 3 oz. (85 grams)

EMC INSTALLATION GUIDELINES

Although Red Lion Controls Products are designed with a high degree of immunity to Electromagnetic Interference (EMI), proper installation and wiring methods must be followed to ensure compatibility in each application. The type of the electrical noise, source or coupling method into a unit may be different for various installations. Cable length, routing, and shield termination are very important and can mean the difference between a successful or troublesome installation. Listed are some EMI guidelines for a successful installation in an industrial environment.

1. Use shielded (screened) cables for all Signal and Control inputs. The shield (screen) pigtail connection should be made as short as possible. The connection point for the shield depends somewhat upon the application. Listed below are the recommended methods of connecting the shield, in order of their effectiveness.
 - a. Connect the shield only at the panel where the unit is mounted to earth ground (protective earth).
 - b. Connect the shield to earth ground at both ends of the cable, usually when the noise source frequency is above 1 MHz.
 - c. Connect the shield to common of the unit and leave the other end of the shield unconnected and insulated from earth ground.
2. Never run Signal or Control cables in the same conduit or raceway with AC power lines, conductors feeding motors, solenoids, SCR controls, and heaters, etc. The cables should be run in metal conduit that is properly grounded. This is especially useful in applications where cable runs are long and portable two-way radios are used in close proximity or if the installation is near a commercial radio transmitter.
3. Signal or Control cables within an enclosure should be routed as far away as possible from contactors, control relays, transformers, and other noisy components.
4. In extremely high EMI environments, the use of external EMI suppression devices, such as ferrite suppression cores, is effective. Install them on Signal and Control cables as close to the unit as possible. Loop the cable through the core several times or use multiple cores on each cable for additional protection. Install line filters on the power input cable to the unit to suppress power line interference. Install them near the power entry point of the enclosure. The following EMI suppression devices (or equivalent) are recommended:

Ferrite Suppression Cores for signal and control cables:

Fair-Rite # 0443167251 (RLC #FCOR0000)

TDK # ZCAT3035-1330A

Steward #28B2029-0A0

Line Filters for input power cables:

Schaffner # FN610-1/07 (RLC #LFIL0000)

Schaffner # FN670-1.8/07

Corcom #1VR3

Note: Reference manufacturer's instructions when installing a line filter.

5. Long cable runs are more susceptible to EMI pickup than short cable runs. Therefore, keep cable runs as short as possible.

INSTALLATION ENVIRONMENT

The unit should be installed in a location that does not exceed the maximum operating temperature and provides good air circulation. Placing the unit near devices that generate excessive heat should be avoided.

The bezel should be cleaned only with a soft cloth and neutral soap product. Do NOT use solvents. Continuous exposure to direct sunlight may accelerate the aging process of the bezel.

Do not use tools of any kind (screwdrivers, pens, pencils, etc.) to operate the keypad of the unit.

Installation

The CUB4 series of products meet NEMA 4X/IP65 requirements for indoor use, when properly installed. The units are intended to be mounted into an enclosed panel. The viewing window and reset button are factory sealed for a washdown environment. A sponge rubber gasket and mounting clip are provided for sealing the unit in the panel cut-out.

The following procedure assures proper installation:

1. Cut panel opening to specified dimensions. Remove burrs and clean around panel opening.
2. Carefully remove the center section of the panel gasket and discard. Slide gasket over rear of the unit to the back of the bezel.
3. Assemble nut fastener first and then mounting screw onto both sides of mounting clip. Tip of screw should not project from hole in mounting clip.
4. Install CUB4 unit through the panel cut-out until front bezel flange contacts the panel-mounted gasket.
5. Slide the mounting clip over the rear of the unit until the mounting clip is against the back of the panel. The mounting clip has latching features which engage into mating features on the CUB4 housing.

Note: It is necessary to hold the unit in place when sliding mounting clip into position.

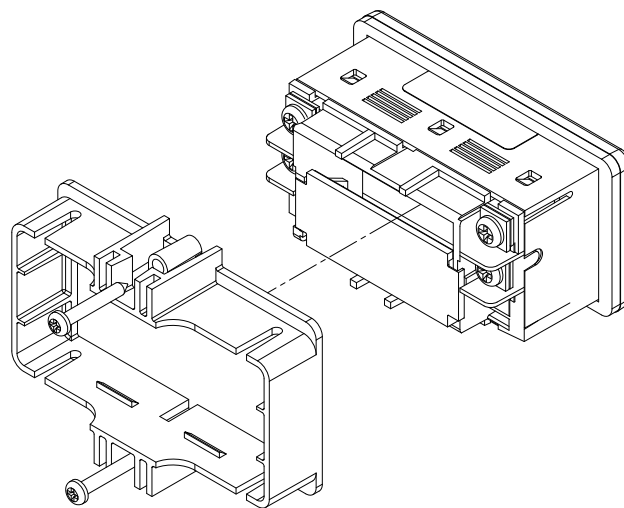

6. Alternately tighten each screw to ensure uniform gasket pressure. Visually inspect the front panel gasket. The gasket should be compressed about 75 to 80% of its original thickness. (Recommended torque is 28 to 36 in-oz.) If not, gradually turn mounting screws to further compress gasket.
7. If gasket is not adequately compressed, and mounting screws can no longer be turned, loosen mounting screws and check that mounting clip is latched as close as possible to panel. Repeat procedure for tightening mounting screws.

WIRING CONNECTIONS

The electrical connections are made via rear screw-clamp terminals located on the back of the unit. When wiring the unit, use the label to identify the wire position with the proper function. All conductors should meet voltage and current ratings for each terminal. Also cabling should conform to appropriate standards of good installation, local codes and regulations. It is recommended that power supplied to the unit (AC or DC) be protected by a fuse or circuit breaker. Strip the wire, leaving approximately 1/4" bare wire exposed (*stranded wires should be tinned with solder*). Insert the wire into the screw-clamp terminal and tighten down the screw until the wire is clamped tightly. Each terminal can accept up to two #14 AWG wires.

Backlight Wiring

Optional backlight versions of the CUB4 require an external 9-28 VDC power supply. The external supply is connected between the V+ and Common terminals.

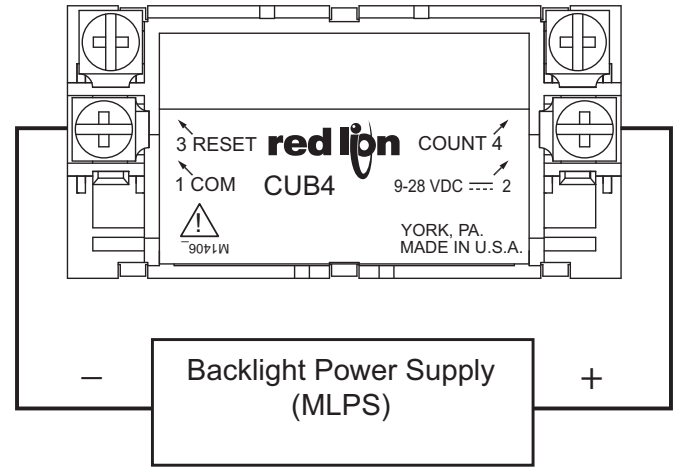

Warning: Lithium battery may explode if incinerated.

COUNT INPUT WIRING

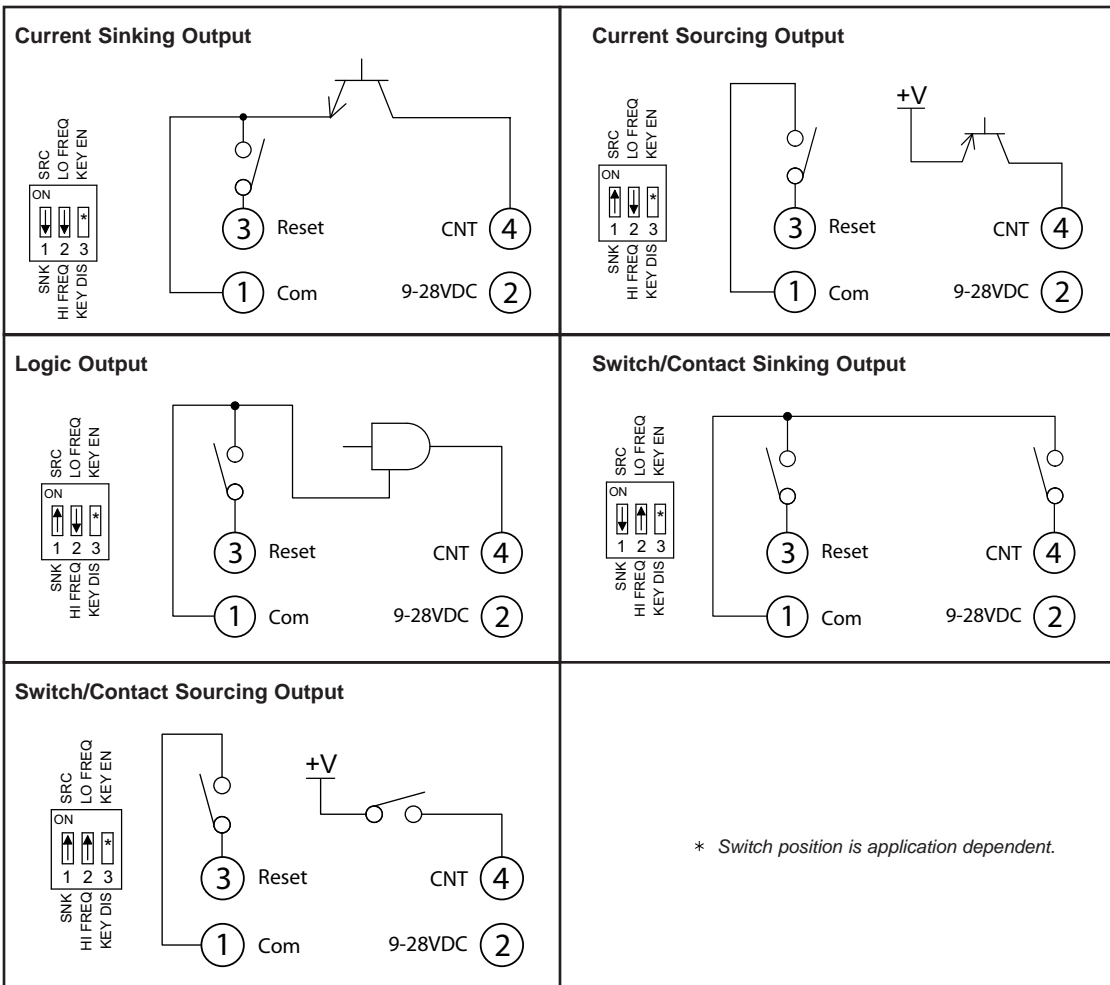

SETTING THE DIP SWITCHES

The switches must be positioned appropriately prior to wiring. Placing the key disable/enable DIP switch in the off position disables the front panel key.

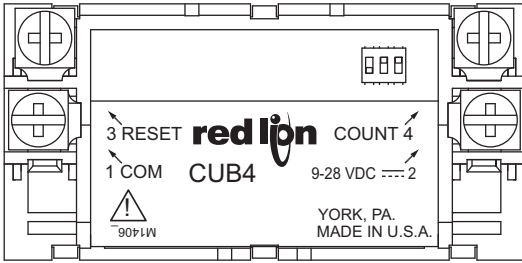

CUB4L

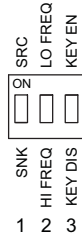

RESETTING THE DISPLAY

The display may be reset to zero via the front RST key, the remote reset input or both. The front RST key must be enabled for front panel reset by setting DIP switch # 3 ON. The remote reset is activated via an external momentary contact closure between the reset input and the common.

TROUBLESHOOTING

For further technical assistance, contact technical support at the appropriate company numbers listed.

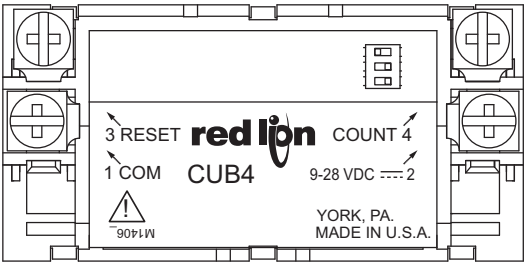

CUB4L8

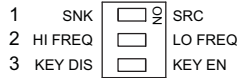

LIMITED WARRANTY

The Company warrants the products it manufactures against defects in materials and workmanship for a period limited to two years from the date of shipment, provided the products have been stored, handled, installed, and used under proper conditions. The Company's liability under this limited warranty shall extend only to the repair or replacement of a defective product, at The Company's option. The Company disclaims all liability for any affirmation, promise or representation with respect to the products.

The customer agrees to hold Red Lion Controls harmless from, defend, and indemnify RLC against damages, claims, and expenses arising out of subsequent sales of RLC products or products containing components manufactured by RLC and based upon personal injuries, deaths, property damage, lost profits, and other matters which Buyer, its employees, or sub-contractors are or may be to any extent liable, including without limitation penalties imposed by the Consumer Product Safety Act (P.L. 92-573) and liability imposed upon any person pursuant to the Magnuson-Moss Warranty Act (P.L. 93-637), as now in effect or as amended hereafter.

No warranties expressed or implied are created with respect to The Company's products except those expressly contained herein. The Customer acknowledges the disclaimers and limitations contained herein and relies on no other warranties or affirmations.

Red Lion Controls
Headquarters
20 Willow Springs Circle
York PA 17406
Tel +1 (717) 767-6511
Fax +1 (717) 764-0839

Red Lion Controls
Europe
Printerweg 10
NL - 3821 AD Amersfoort
Tel +31 (0) 334 723 225
Fax +31 (0) 334 893 793

Red Lion Controls
India
54, Vishvas Tenement
GST Road, New Ranip,
Ahmedabad-382480 Gujarat, India
Tel +91 987 954 0503
Fax +91 79 275 31 350

Red Lion Controls
China
Unit 101, XinAn Plaza
Building 13, No.99 Tianzhou Road
ShangHai, P.R. China 200223
Tel +86 21 6113-3688
Fax +86 21 6113-3683