

NOTES:

1. MATERIALS AND FINISHES:

- ① BODY - COPPER ALLOY, GOLD PL. 3u" MIN. THICK OVER NICKEL PL. 80u" MIN. THICK
- ② CONTACT A - COPPER ALLOY, GOLD FLASH PLATING OVER 80u" MIN. NICKEL IN SOLDER AREA
15u" MIN. GOLD PLATING OVER 80u" MIN. NICKEL IN CONTACT AREA
- ③ CONTACT C - COPPER ALLOY, GOLD FLASH PLATING OVER 80u" MIN. NICKEL IN SOLDER AREA
15u" MIN. GOLD PLATING OVER 80u" MIN. NICKEL IN CONTACT AREA
- ④ INSULATOR - LCP, BLACK, UL 94V-0

2. ELECTRICAL:

- A. IMPEDANCE: 50 OHM
- B. FREQUENCY RANGE: DC - 2.5 GHz
- C. VSWR: UNMATED: 1.2 FROM DC TO 2.5 GHz
1.3 FROM 2 GHz TO 2.5 GHz
MATED: 1.25 FROM DC TO 2 GHz
1.35 FROM 2 GHz TO 2.5 GHz
- D. INSERTION LOSS: UNMATED: 0.15 dB MAX FROM DC TO 2 GHz
0.20 dB MAX FROM 2 GHz TO 2.5 GHz
MATED: 0.20 dB MAX FROM DC GHz TO 2 GHz
0.30 dB MAX FROM 2 GHz TO 2.5 GHz
- E. ISOLATION: 25 dB MIN FROM DC TO 2 GHz
20 dB MIN FROM 2 GHz TO 2.5 GHz
- F. VOLTAGE RATING: 100 VAC
- G. CURRENT RATING: 1 A
- H. POWER RATING: 4 W
- J. CONTACT RESISTANCE: CENTER CONTACT: 75 mΩ MAX
OUTER CONTACT: 50 mΩ MAX
- K. DIELECTRIC WITHSTANDING VOLTAGE: 100 VRMS

3. MECHANICAL:

- A. DURABILITY: 1200 CYCLES MIN.
- B. TEMPERATURE RANGE: -30°C TO +85°C
- C. MECHANICAL SHOCK: PER MIL-STD-202F METHOD 213B, COND B
- D. VIBRATION: PER MIL-STD-202F METHOD 204D, COND A
- E. HUMIDITY: PER MIL-STD-202F METHOD 103B, COND B
- F. SUITABLE FOR LEAD FREE REFLOW, 260°C PEAK TEMPERATURE

4. PACKAGING:

- A. QUANTITY: TAPE AND REEL, 1200 PCS/REEL
- B. MARKING: REEL TO BE MARKED
"AMPHENOL, 902-9224, AND DATE CODE"

THIRD ANGLE PROJ.

REVISIONS

REV	DESCRIPTION	DATE	ECO	APPR
A	RELEASE TO MFG.	15-Jul-14		JTS
B	THE OLD DRAWING INSULATOR MISS A CRACK; CORRECT PLATING AND ISOLATION /RD-DMI703090IT3	17-Mar-17		TL

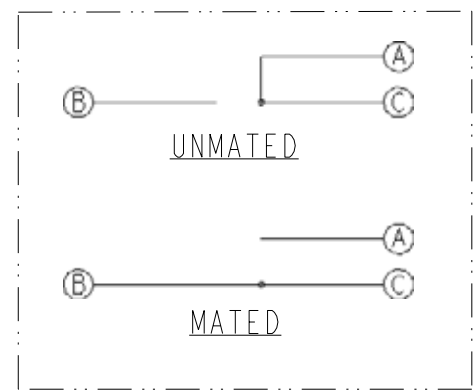
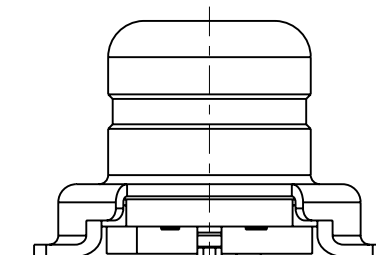
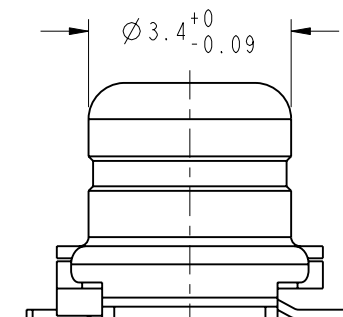
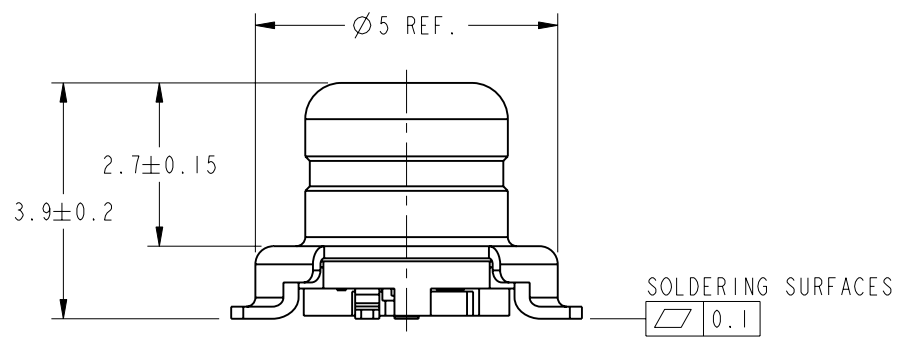
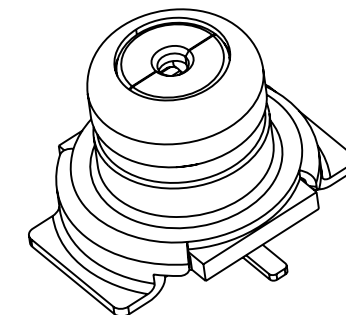
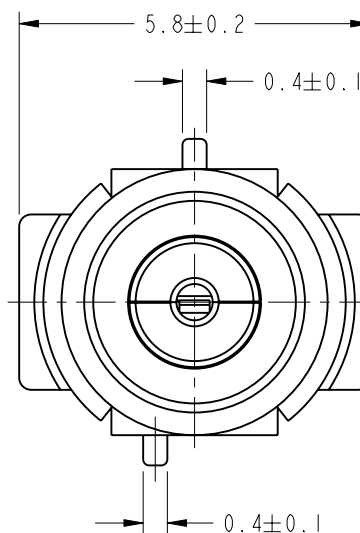

CIRCUIT DIAGRAM

- A = "A" TERMINAL
- B = MATING PLUG
- C = "C" TERMINAL
- G = GROUND

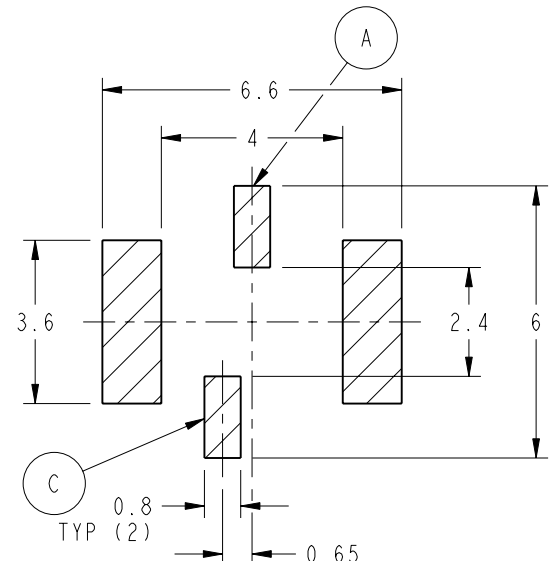

RECOMMENDED PCB LAYOUT

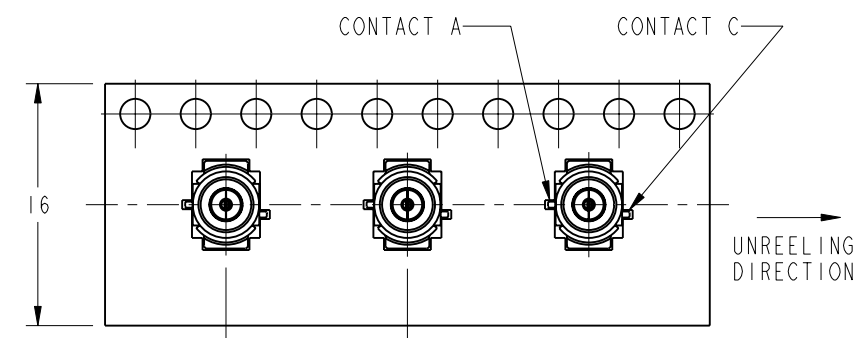
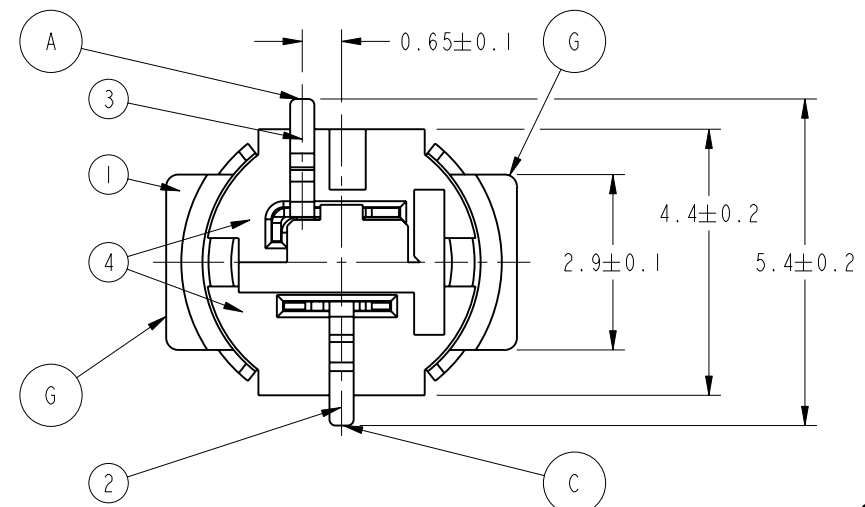

TAPE AND REEL DETAIL

CUSTOMER OUTLINE DRAWING
ALL OTHER SHEETS ARE FOR INTERNAL USE ONLY

<p>UNLESS OTHERWISE SPECIFIED, DIMENSIONS ARE IN METRIC AND TOLERANCES ARE: <0.5mm ± 0.05mm 0.5 - 6mm ± 0.1mm 6 - 30mm ± 0.2mm 30 - 120mm ± 0.3mm ANGLES ± 1°</p> <p>NOTICE - These drawings, specifications, or other data (1) are, and remain the property of Amphenol corp. (2) must be returned upon request; and (3) are confidential and not to be disclosed to any person other than those to whom they are given by Amphenol Corp. the furnishing of these drawings, specifications, or other data by Amphenol Corp., or to any other person to anyone for any purpose is not to be regarded by implication or otherwise in any manner licensing, granting rights to permitting such holder or any other person to manufacture, use or sell any product, process or design, patented or otherwise, that may in any way be related to or disclosed by said drawings, specifications, or other data.</p>	MATERIAL	DRAWN TOM	DATE 22-Mar-17	TITLE AMS AMPHENOL MICRO SWITCH WITH DETENT		Amphenol RF www.amphenolrf.com		
	REFERENCE EAR # AND CONFIGURATION LEVEL:	APPROVED S.H	DATE 22-Mar-17	SCALE: 8.0:1.0	SHEET 2 OF 2	DRAWING NO. 902-9224		
	FINISH	CAD FILE	DWG SIZE B	REV B	ITEM NO. 902-9224		PART NO. 902-9224	