

## Ultrasonic sensor UC6000-30GM-IUR2-V15



### Features

- Parameterisation interface for the application-specific adjustment of the sensor setting via the service program ULTRA 2001
- Current and voltage output
- Synchronisation options
- Adjustable acoustic power and sensitivity
- Temperature compensation

### Electrical connection

Standard symbol/Connection:  
(version IU)

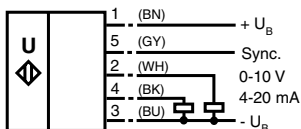

Core colours in accordance with EN 60947-5-2.

### Connector V15



### Dimensions

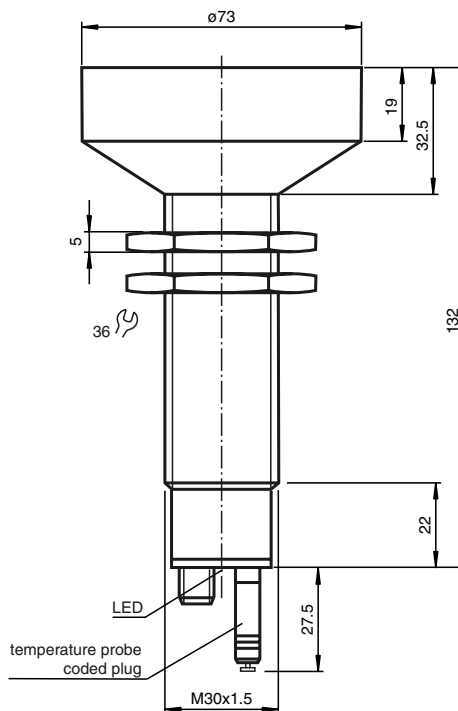

### Technical data



#### General specifications

Sensing range	350 ... 6000 mm
Adjustment range	400 ... 6000 mm
Unusable area	0 ... 350 mm
Standard target plate	100 mm x 100 mm
Transducer frequency	approx. 65 kHz
Response delay	285 ms minimum 850 ms factory setting

#### Indicators/operating means

LED green	permanent: Power-on flashing: Standby mode or TEACH-IN function object detected
LED yellow 1	permanent: object in evaluation range flashing: TEACH-IN function
LED yellow 2	permanent: object in detection range flashing: TEACH-IN function
LED red	permanent: temperature/TEACH-IN plug not connected flashing: fault or TEACH-IN function object not detected
Temperature/TEACH-IN connector	temperature compensation, TEACH-IN for evaluation range, output function setting

#### Electrical specifications

Operating voltage	10 ... 30 V DC, ripple 10 % <sub>SS</sub>
Power consumption P <sub>0</sub>	≤ 900 mW

#### Interface

Interface type	RS 232, 9600 Bit/s, no parity, 8 data bits, 1 stop bit
----------------	--

#### Input/Output

Synchronisation	bi-directional 0 level -U <sub>B</sub> ...+1 V 1 level: +4 V...+U <sub>B</sub> input impedance: > 12 KOhm synchronisation pulse: ≥ 100 μs, synchronisation interpulse period: ≥ 2 ms
-----------------	--

#### Synchronisation frequency

Common mode operation	≤ 7 Hz
Multiplex operation	≤ 7/n Hz, n = number of sensors

#### Output

Output type	1 current output 4 ... 20 mA 1 voltage output 0 ... 10 V evaluation range [mm]/4000, but ≥ 0,35 mm
-------------	--

#### Resolution

Deviation of the characteristic curve	≤ 0,2 % of full-scale value
---------------------------------------	-----------------------------

#### Repeat accuracy

Repeat accuracy	≤ 0,1 % of full-scale value
-----------------	-----------------------------

#### Load impedance

Load impedance	current output: ≤ 500 Ohm Voltage output: ≥ 1000 Ohm
----------------	---

#### Temperature influence

Temperature influence	≤ 2 % from full-scale value (with temperature compensation) ≤ 0.2 %/K (without temperature compensation)
-----------------------	---

#### Standard conformity

Standards	EN 60947-5-2
-----------	--------------

#### Ambient conditions

Ambient temperature	-25 ... 70 °C (248 ... 343 K)
Storage temperature	-40 ... 85 °C (233 ... 358 K)

#### Mechanical specifications

Protection degree	IP65
Connection	connector V15 (M12 x 1), 5 pin

#### Material

Housing	stainless steel 1.4303 plastic parts PBT
Transducer	epoxy resin/hollow glass sphere mixture; polyurethane foam
Mass	280 g

### Description of the sensor functions

This ultrasonic sensor features a four-pole temperature/TEACH-IN plug, that can be connected in four different positions. These have the following significance.

Plug position	Meaning
A1	TEACH-IN evaluation limit A1
A2	TEACH-IN evaluation limit A2
E2/E3	Rising/falling ramp/output characteristic of the voltage output by zero point
T	Temperature compensation

### Description of the TEACH-IN procedure

#### TEACH-IN the evaluation limits 1 or 2

- Cut supply voltage
  - Remove TEACH-IN plug
  - Restore supply voltage (Reset)
  - Set object to desired switching point
  - Plug and remove the TEACH-IN plug in pos. A1 or A2. This teaches the evaluation limits A1 or A2.
- Caution:** Removing the temperature/TEACH-IN plug, the values of the object position will be adopted.
- The TEACH-IN procedure is controlled with the LED. The green LED flashes, when object is detected, the red LED flashes when no object is detected.
  - Connect TEACH-IN plug in pos. T. This completes the TEACH-IN procedure and saves the distance.
  - The sensor works in normal mode

#### TEACH-IN the analogue function

- Cut supply voltage
- Remove TEACH-IN plug
- Restore supply voltage (Reset)
- Connect TEACH-IN plug in pos. E2/E3. By multiple plugging, three different modes of operation can be set in cyclical sequence:
  - 1) rising ramp, LED A2 flashes,
  - 2) falling ramp, LED A1 flashes,
  - 3) zero line, LED A1 and A2 flash
- Connect TEACH-IN plug in pos. T. This completes the TEACH-IN procedure and saves the mode of operation.
- The sensor works in normal mode

**Note:** If the temperature/TEACH-IN plug has not been plugged in within 5 minutes in position T, the sensor will return to normal mode (with the latest permanent stored values) without temperature compensation.

### Synchronisation

The sensor features a synchronisation input for the suppression of mutual interference. If this input is not used, the sensor will operate using an internally generated clock rate. It can be synchronised by applying a square wave voltage. A falling edge leads to the transmission of a single ultrasonic pulse. A low level  $\geq 1$  s or an open synchronisation input will result in the normal operation of the sensor.

A high level  $> 1$  s will result in the standby mode of the sensor (indicator green LED). The outputs pause in the latest status.

Synchronisation cannot be performed during TEACH-IN and vice versa.

Multiple operating modes are possible:

1. Two to five sensors can be synchronised by interconnecting their synchronisation inputs. In this case, the sensors alternately transmit ultrasonic pulses.
2. Multiple sensors can be controlled by the same synchronisation signal. The sensors are synchronised.
3. The synchronisation pulses are sent cyclically to individual sensors. The sensors operate in multiplex mode.
4. A high level at the synchronisation input disables the sensor.

The response time increases when the sensor is synchronised, because the synchronisation increases the measurement cycle time.

#### Note:

If the option for synchronisation is not used, the synchronisation input has to be connected to ground (0V) or the sensor has to be operated via a V1 cable connector (4-pin).

## UC6000-30GM-IUR2-V15

### Characteristic curves/additional information

#### Characteristic response curve

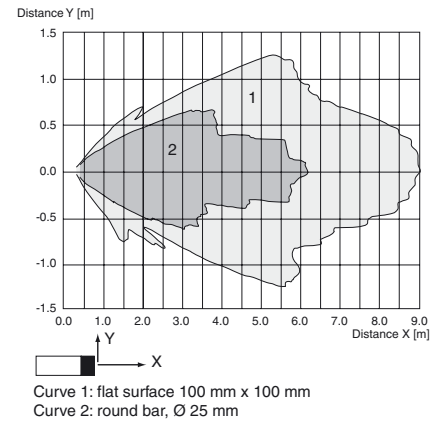

#### Programmed analogue output function

##### Analogue function

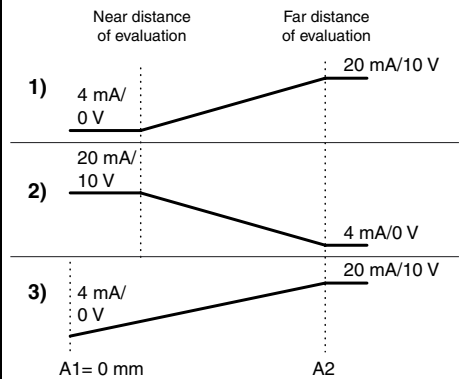

**Default setting**

A1: unusable area  
 A2: nominal sensing range  
 Mode of operation: rising ramp

**LED Displays/Analogue output**

Displays in dependence on operating mode	Dual LED green	Dual-LED red	LED yellow A1	LED yellow A2	analogue output
TEACH-IN evaluation limit A1 object detected object not detected	flashing off	off flashing	flashing flashing	off off	unchanged
TEACH-IN evaluation limit A2 object detected object not detected	flashing off	off flashing	off off	flashing flashing	unchanged
TEACH-IN mode of operation (E2/E3) rising ramp falling ramp zero line	on on on	off off off	off flashing flashing (synchronised)	flashing off flashing (synchronised)	unchanged
Normal mode temperature compensated plug pulled/shorted	on off	off on	on, if target in evaluation range	on, if target in detection range	analogue value
Standby	flashing	off	previous state	previous state	unchanged
Interference (e.g. compressed air)	off	flashing	previous state	previous state	unchanged or error value

**LED-Window**

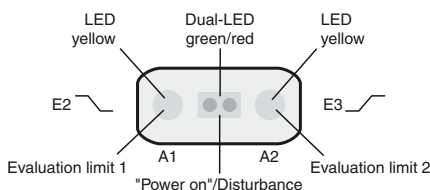

**RS 232-connection**

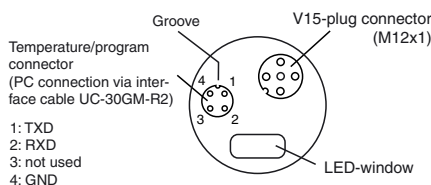

**Note on communication with the UC-30GM-R2 interface cable**

The UC-30GM-R2 interface cable allows for communication with the ultrasonic sensor using the ULTRA 2001 service program. The cable creates a connection between the PC-internal RS 232 interface and the plug-in connection for the temperature/program plug on the sensor. When setting up the connection on the sensor, make certain the plug is lined up correctly; otherwise no communication will be possible. The protrusion of the round plug must be inserted into the groove of the plug connection on the sensor side and **not** into the arrow symbol on the sensor.

**Adjustable parameter with service program ULTRA 2001**

- Evaluation limits A1 and A2
- Rising/falling ramp/zero line
- Mode of operation
- Sonic speed
- Temperature offset (The inherent temperature-rise of the sensor can be considered in the temperature compensation)
- Expansion of the unusable area (for suppression of unusable area echoes)
- Reduction of the detection range (for suppression of remote range echoes)
- Time of measuring cycle
- Acoustic power (interference of the burst duration)
- Sensitivity
- Behaviour of the sensor in case of echo loss
- Behaviour of the sensor in case of a fault
- Average formation via an allowed number of measuring cycles
- Selection of the parameter set, RS 232 or manually.

**Accessories**

**Mounting aids**

BF30  
 BF5-30

**External temperature probe**

UC-30GM-TEMP

**Extension cable**

UC-30GM-PROG

**Programming tools**

Service program ULTRA 2001

Interface cable UC-30GM-R2

**Process indication- and control unit**

DA5-IU-2K-V

**Cable sockets \*)**

V15-G-2M-PVC

V15-W-2M-PUR

\*) For additional cable sockets see section „Accessories“.