

# TPS40200 Wide Input Range Non-Synchronous Voltage Mode Controller

## 1 Features

- Input Voltage Range 4.5 V to 52 V
- Output Voltage (700 mV to 90%  $V_{IN}$ )
- 200-mA Internal P-channel FET Driver
- Voltage Feed-Forward Compensation
- Undervoltage Lockout
- Programmable Fixed-Frequency (between 35 kHz and 500 kHz) Operation
- Programmable Short-Circuit Protection
- Hiccup Overcurrent Fault Recovery
- Programmable Closed-Loop Soft-Start
- 700 mV 1% Reference Voltage
- External Synchronization
- Small 8-Pin SOIC (D) and VSON (DRB) Packages

## 2 Applications

- Industrial Control
- Distributed Power Systems
- DSL/Cable Modems
- Scanners
- Telecom

## 3 Description

The TPS40200 is a flexible, non-synchronous controller with a built-in 200-mA driver for P-channel FETs. The circuit operates with inputs up to 52 V with a power-saving feature that turns off driver current once the external FET has been fully turned on. This feature extends the flexibility of the device, allowing it to operate with an input voltage up to 52 V without dissipating excessive power. The circuit operates with voltage-mode feedback and has feed-forward input voltage compensation that responds instantly to input voltage change. The integral 700-mV reference is trimmed to 2%, providing the means to accurately control low voltages. The TPS40200 is available in an 8-pin SOIC and an 8-pin VSON package and supports many of the features of more complex controllers. Clock frequency, soft-start, and overcurrent limits are each easily programmed by a single, external component. The part has undervoltage lockout, and can be easily synchronized to other controllers or a system clock to satisfy sequencing and/or noise-reduction requirements.

### Device Information<sup>(1)</sup>

PART NUMBER	PACKAGE	BODY SIZE (NOM)
TPS40200	VSON (8)	3.00 mm x 3.00 mm
	SOIC (8)	4.90 mm x 3.90 mm

(1) For all available packages, see the orderable addendum at the end of the datasheet.

### Simplified Schematic

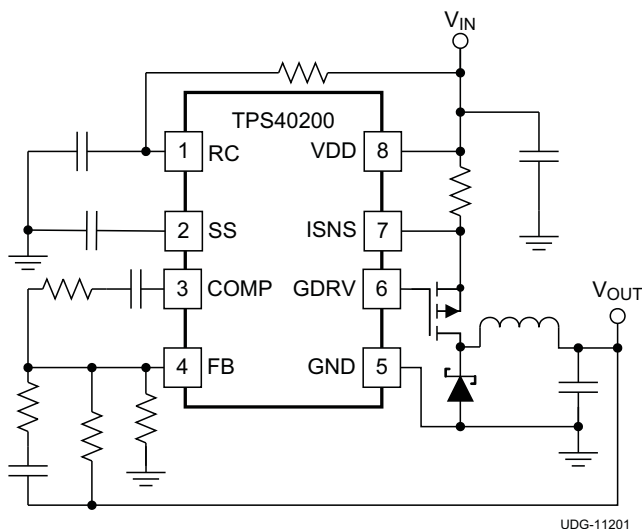

### Efficiency vs Output Current

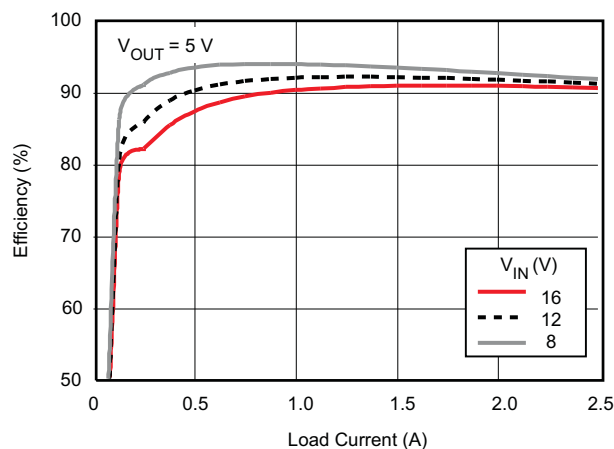

## Table of Contents

<b>1 Features</b> .....	<b>1</b>	7.4 Device Functional Modes.....	<b>18</b>
<b>2 Applications</b> .....	<b>1</b>	<b>8 Application and Implementation</b> .....	<b>19</b>
<b>3 Description</b> .....	<b>1</b>	8.1 Application Information.....	<b>19</b>
<b>4 Revision History</b> .....	<b>2</b>	8.2 Typical Application .....	<b>19</b>
<b>5 Pin Configuration and Functions</b> .....	<b>3</b>	<b>9 Power Supply Recommendations</b> .....	<b>37</b>
<b>6 Specifications</b> .....	<b>4</b>	<b>10 Layout</b> .....	<b>37</b>
6.1 Absolute Maximum Ratings .....	4	10.1 Layout Guidelines .....	37
6.2 Handling Ratings .....	4	10.2 Layout Example .....	38
6.3 Recommended Operating Conditions.....	4	<b>11 Device and Documentation Support</b> .....	<b>39</b>
6.4 Thermal Information .....	4	11.1 Device Support .....	39
6.5 Electrical Characteristics.....	5	11.2 Documentation Support .....	39
6.6 Typical Characteristics.....	7	11.3 Trademarks .....	39
<b>7 Detailed Description</b> .....	<b>11</b>	11.4 Electrostatic Discharge Caution.....	39
7.1 Overview .....	11	11.5 Glossary .....	39
7.2 Functional Block Diagram .....	11	<b>12 Mechanical, Packaging, and Orderable</b>	
7.3 Feature Description.....	11	<b>Information</b> .....	<b>39</b>

## 4 Revision History

<b>Changes from Revision F (September 2014) to Revision G</b>	<b>Page</b>
<ul style="list-style-type: none"> <li>Changed Added <i>Handling Rating</i> table, <i>Feature Description</i> section, <i>Device Functional Modes</i>, <i>Application and Implementation</i> section, <i>Power Supply Recommendations</i> section, <i>Layout</i> section, <i>Device and Documentation Support</i> section, and <i>Mechanical, Packaging, and Orderable Information</i> section. ....</li> </ul>	<b>1</b>

## 5 Pin Configuration and Functions

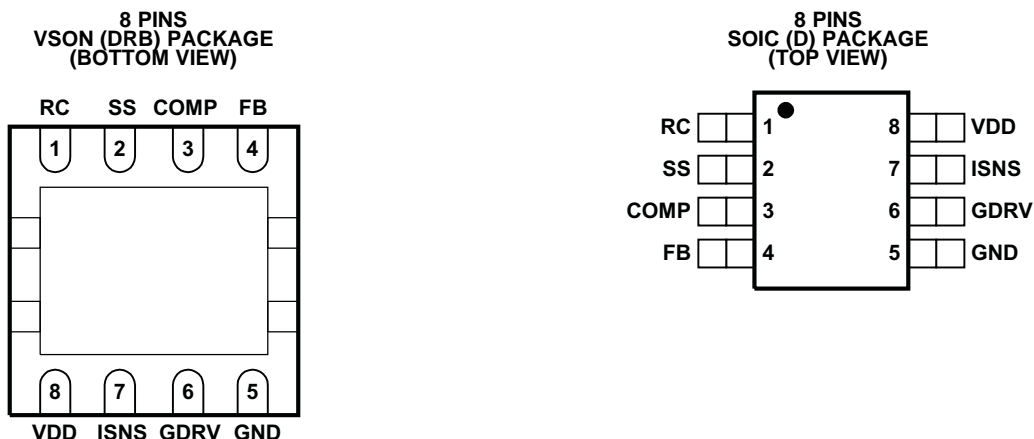

### Pin Functions

PIN		I/O	DESCRIPTION
NAME	NO.		
COMP	3	O	Error amplifier output. Connect control loop compensation network from COMP to FB.
FB	4	I	Error amplifier inverting input. Connect feedback resistor network center tap to this pin.
GND	5		Device ground.
GDRV	6	O	Driver output for external P-channel MOSFET
ISNS	7	I	Current-sense comparator input. Connect a current sense resistor between ISNS and VDD in order to set desired overcurrent threshold.
RC	1	I	Switching frequency setting RC network. Connect a capacitor from the RC pin to the GND pin and connect a resistor from the VDD pin to the RC pin. The device may be synchronized to an external clock by connecting an open drain output to this pin and pulling it to GND. For mor info on pulse width for synchronization, please refer to the <a href="#">Synchronizing the Oscillator</a> section.
SS	2	I	Soft-start programming pin. Connect capacitor from SS to GND to program soft start time. Pulling this pin below 150 mV causes the output switching to stop, placing the device in a shutdown state. The pin also functions as a restart timer for overcurrent events.
VDD	8	I	System input voltage. Connect local bypass capacitor from VDD to GND.

## 6 Specifications

### 6.1 Absolute Maximum Ratings

 over operating free-air temperature range (unless otherwise noted) <sup>(1)</sup>

		MIN	MAX	UNIT
Input voltage range	V <sub>DD</sub> , ISNS	-0.3	52	V
	RC, FB	-0.3	5.5	
	SS	-0.3	9.0	
Output voltage range	COMP	-0.3	9.0	V
	GDRV	V <sub>IN</sub> -10	V <sub>IN</sub>	
T <sub>J</sub>	Operating Junction Temperature	-40	125	°C
	Lead temperature 1,6 mm (1/16 inch) from case for 10 seconds		260	

- (1) Stresses beyond those listed under *Absolute Maximum Ratings* may cause permanent damage to the device. These are stress ratings only, which do not imply functional operation of the device at these or any other conditions beyond those indicated under *Recommended Operating Conditions*. Exposure to absolute-maximum-rated conditions for extended periods may affect device reliability.

### 6.2 Handling Ratings

		MIN	MAX	UNIT	
T <sub>stg</sub>	Storage temperature range	-55	150	°C	
V <sub>(ESD)</sub>	Electrostatic discharge	Human body model (HBM), per ANSI/ESDA/JEDEC JS-001, all pins <sup>(1)</sup>	-1500	1500	V
		Charged device model (CDM), per JEDEC specification JESD22-C101, all pins <sup>(2)</sup>	-1500	1500	

- (1) JEDEC document JEP155 states that 500 V HBM allows safe manufacturing with a standard ESD control process.  
 (2) JEDEC document JEP157 states that 250 V CDM allows safe manufacturing with a standard ESD control process.

### 6.3 Recommended Operating Conditions

over operating free-air temperature range (unless otherwise noted)

		MIN	MAX	UNIT
V <sub>DD</sub>	Input voltage	4.5	52	V
T <sub>J</sub>	Operating temperature range	-40	125	°C

### 6.4 Thermal Information

THERMAL METRIC <sup>(1)</sup>		D	DRB	UNIT
		SOIC	VSON	
		(8 PINS)	(8 PINS)	
R <sub>θJA</sub>	Junction-to-ambient thermal resistance	109.6	44.2	°C/W
R <sub>θJC(top)</sub>	Junction-to-case (top) thermal resistance	54.0	53.6	
R <sub>θJB</sub>	Junction-to-board thermal resistance	49.6	19.8	
ψ <sub>JT</sub>	Junction-to-top characterization parameter	11.2	1.1	
ψ <sub>JB</sub>	Junction-to-board characterization parameter	49.1	19.9	
R <sub>θJC(bot)</sub>	Junction-to-case (bottom) thermal resistance	N/A	7.9	

- (1) For more information about traditional and new thermal metrics, see the *IC Package Thermal Metrics* application report, [SPRA953](#).

## 6.5 Electrical Characteristics

 $-40^{\circ}\text{C} < T_A = T_J < 85^{\circ}\text{C}$ ,  $V_{DD} = 12\text{ V}$ ,  $f_{OSC} = 100\text{ kHz}$  (unless otherwise noted)

PARAMETER		TEST CONDITIONS	MIN	TYP	MAX	UNIT	
<b>VOLTAGE REFERENCE</b>							
$V_{FB}$	Feedback voltage	COMP = FB, $T_A = 25^{\circ}\text{C}$	689	696	702	mV	
		$4.5 < V_{DD} < 52$	$T_A = 25^{\circ}\text{C}$	686	696		703
			$-40^{\circ}\text{C} < T_A < 85^{\circ}\text{C}$	679	696		708
			$-40^{\circ}\text{C} < T_A < 125^{\circ}\text{C}$	679	696		710
<b>GATE DRIVER</b>							
$I_{src}$	Gate driver pull-up current		125	300		mA	
$I_{snk}$	Gate driver pull-down current		200	300		mA	
$V_{GATE}$	Gate driver output voltage	$V_{GATE} = (V_{DD} - V_{GDRV})$ , for $12 < V_{DD} < 52$	6	8	10	V	
<b>QUIESCENT CURRENT</b>							
$I_{qq}$	Device quiescent current	$f_{OSC} = 300\text{ kHz}$ , Driver not switching, $4.5 < V_{DD} < 52$		1.5	3.0	mA	
<b>UNDERVOLTAGE LOCKOUT (UVLO)</b>							
$V_{UVLO(on)}$	Turn-on threshold	$-40^{\circ}\text{C} < T_A < 125^{\circ}\text{C}$	3.8	4.25	4.5	V	
$V_{UVLO(off)}$	Turn-off threshold			4.05			
$V_{UVLO(HYST)}$	Hysteresis		110	200	275	mV	
<b>SOFT-START</b>							
$R_{SS(chg)}$	Internal soft-start pull-up resistance		65	105	170	k $\Omega$	
$R_{SS(dchg)}$	Internal soft-start pull-down resistance		190	305	485		
$V_{SSRST}$	Soft-start reset threshold		100	150	200	mV	
<b>OVERCURRENT PROTECTION</b>							
$V_{ILIM}$	Overcurrent threshold	$4.5 < V_{DD} < 52$	$0^{\circ}\text{C} < T_A < 125^{\circ}\text{C}$	65	100	140	mV
			$-40^{\circ}\text{C} < T_A < 125^{\circ}\text{C}$	55	100	140	
$OC_{DF}$	Overcurrent duty cycle <sup>(1)</sup>				2%		
$V_{ILIM(rst)}$	Overcurrent reset threshold		100	150	200	mV	
<b>OSCILLATOR</b>							
$f_{OSC}$	Oscillator frequency range <sup>(1)</sup>		35		500	kHz	
	Oscillator frequency	$R_{RC} = 200\text{ k}\Omega$ , $C_{RC} = 470\text{ pF}$	85	100	115		
		$R_{RC} = 68.1\text{ k}\Omega$ , $C_{RC} = 470\text{ pF}$	255	300	345		
Frequency line regulation	$12\text{ V} < V_{DD} < 52\text{ V}$		-9%		0%		
	$4.5\text{ V} < V_{DD} < 12\text{ V}$		-20%		0%		
$V_{RMP}$	Ramp amplitude	$4.5\text{ V} < V_{DD} < 52\text{ V}$		$V_{DD} \div 10$		V	

(1) Ensured by design. Not production tested.

**Electrical Characteristics (continued)**
 $-40^{\circ}\text{C} < T_A = T_J < 85^{\circ}\text{C}$ ,  $V_{DD} = 12\text{ V}$ ,  $f_{OSC} = 100\text{ kHz}$  (unless otherwise noted)

PARAMETER		TEST CONDITIONS	MIN	TYP	MAX	UNIT
<b>PULSE WIDTH MODULATOR</b>						
$t_{MIN}$	Minimum controllable pulse width <sup>(2)</sup>	$V_{DD} = 12\text{ V}$		200	400	ns
		$V_{DD} = 30\text{ V}$		100	200	
$D_{MAX}$	Maximum duty cycle	$f_{OSC} = 100\text{ kHz}$ , $C_L = 470\text{ pF}$	93%	95%		
		$f_{OSC} = 300\text{ kHz}$ , $C_L = 470\text{ pF}$	90%	93%		
$K_{PWM}$	Modulator and power stage DC gain		8	10	12	V/V
<b>ERROR AMPLIFIER</b>						
$I_{IB}$	Input bias current			100	250	nA
AOL	Open loop gain <sup>(1)</sup>		60	80		dB
GBWP	Unity gain bandwidth <sup>(1)</sup>		1.5	3		MHz
$I_{COMP(src)}$	Output source current	$V_{FB} = 0.6\text{ V}$ , $COMP = 1\text{ V}$	100	250		$\mu\text{A}$
$I_{COMP(snk)}$	Output sink current	$V_{FB} = 1.2\text{ V}$ , $COMP = 1\text{ V}$	1.0	2.5		mA

(2) See [Figure 21](#) for for  $t_{MIN}$  vs  $f_{OSC}$  at various input voltages.

## 6.6 Typical Characteristics

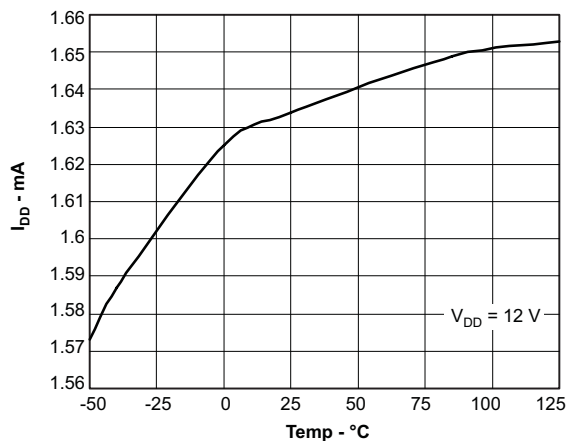

Figure 1. Quiescent Current vs Temperature

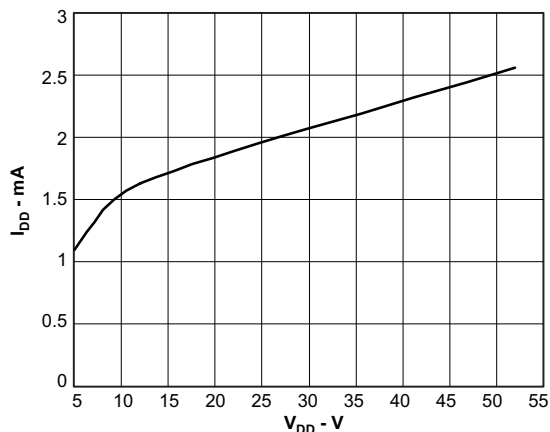

Figure 2. Quiescent Current vs Input Voltage

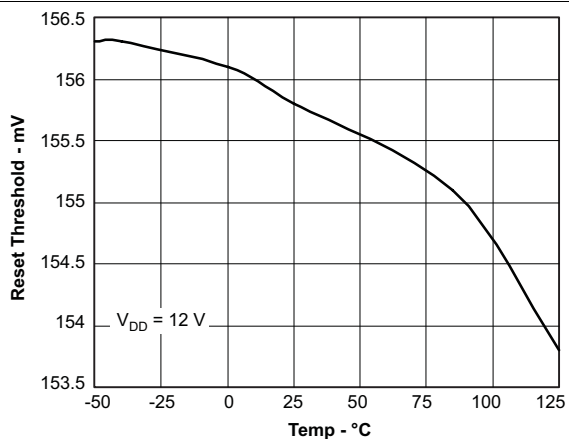

Figure 3. Soft-Start Threshold vs Temperature

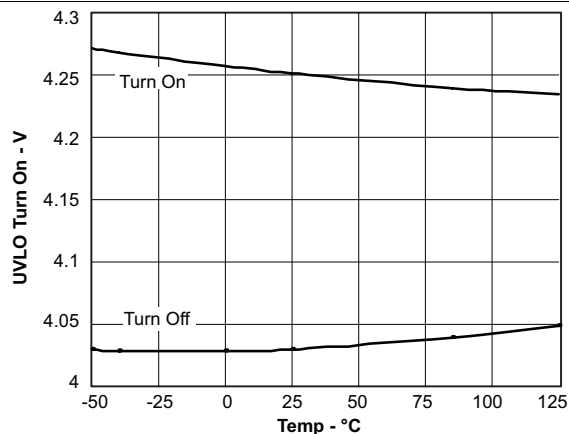

Figure 4. UVLO Turn-On and Turn-Off vs Temperature

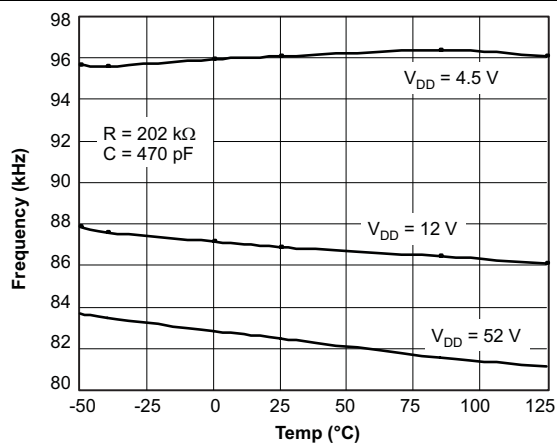

Figure 5. Oscillator Frequency vs Temperature

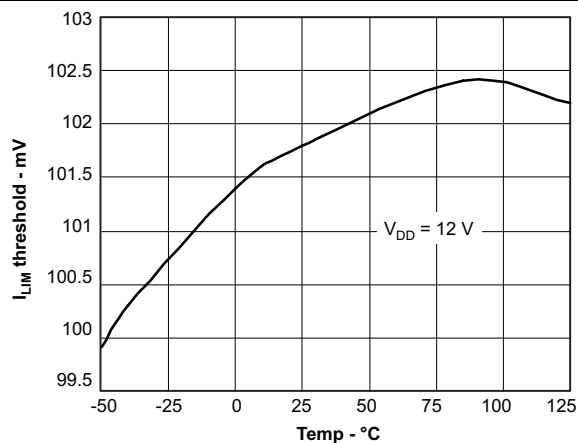
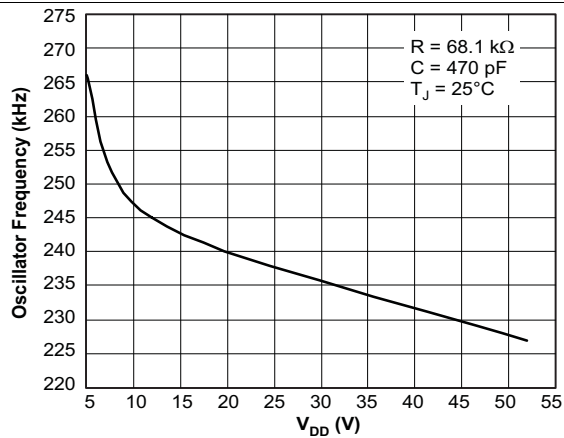
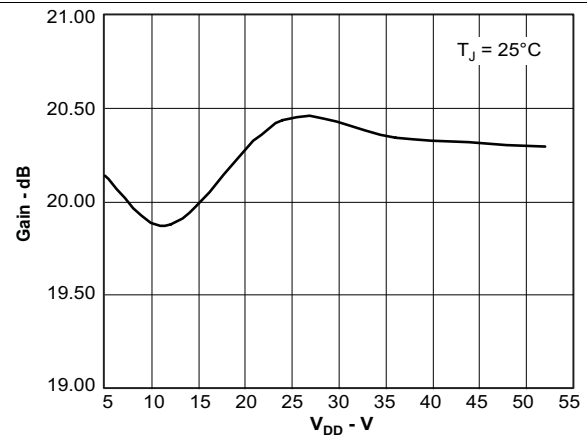
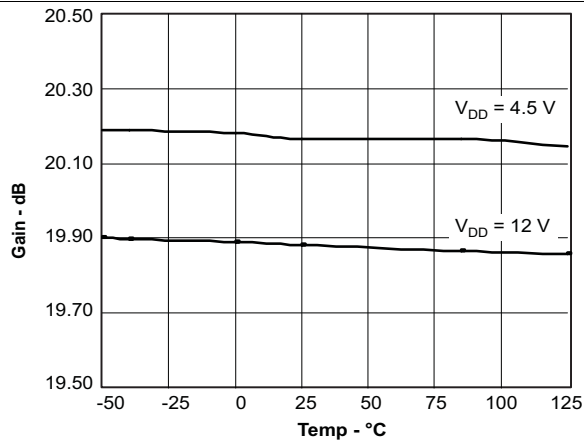
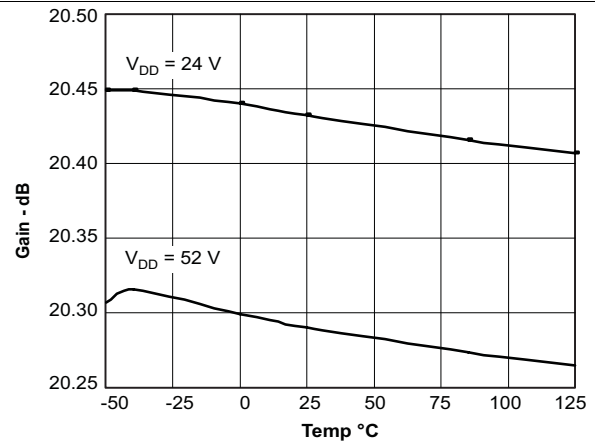
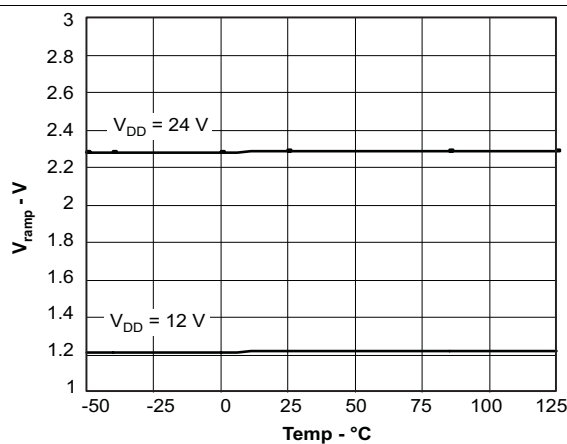
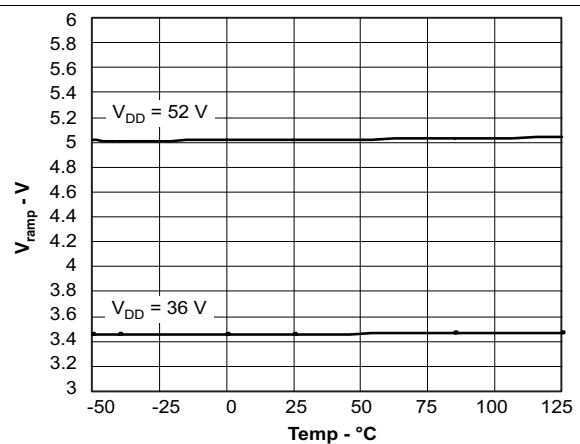

Figure 6. Current Limit Threshold vs Temperature

**Typical Characteristics (continued)**

**Figure 7. Oscillator Frequency vs VDD**

**Figure 8. Power Stage Gain vs VDD**

**Figure 9. Power Stage Gain vs Temperature**

**Figure 10. Power Stage Gain vs Temperature**

**Figure 11. Modulator Ramp Amplitude vs Temperature**

**Figure 12. Modulator Ramp Amplitude vs Temperature**



Typical Characteristics (continued)

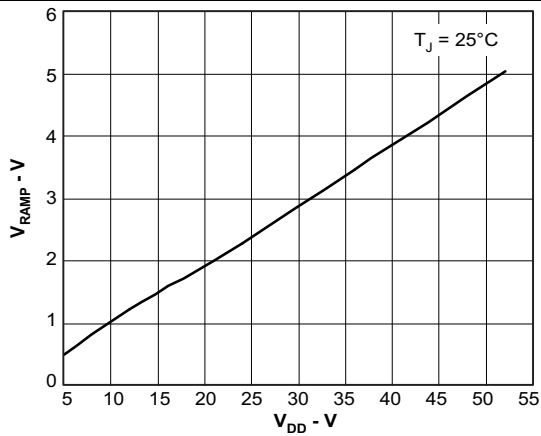

Figure 13. Modulator Ramp Amplitude vs VDD

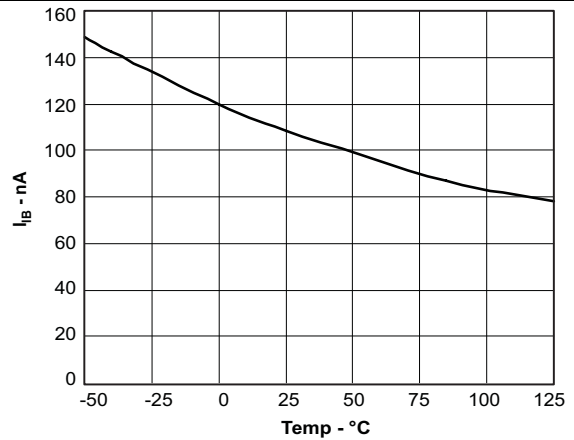

Figure 14. Feedback Amplifier Input Bias Current vs Temperature

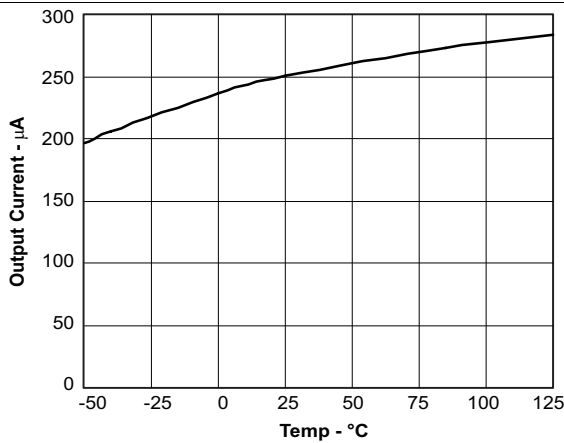

Figure 15. Comp Source Current vs Temperature

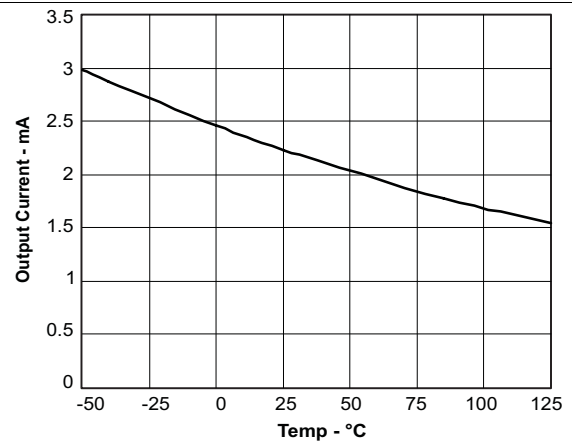

Figure 16. Comp Sink Current vs Temperature

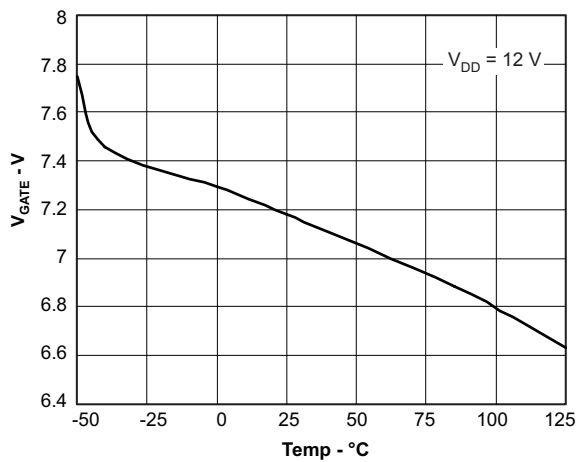

Figure 17. Gate Drive Voltage vs Temperature

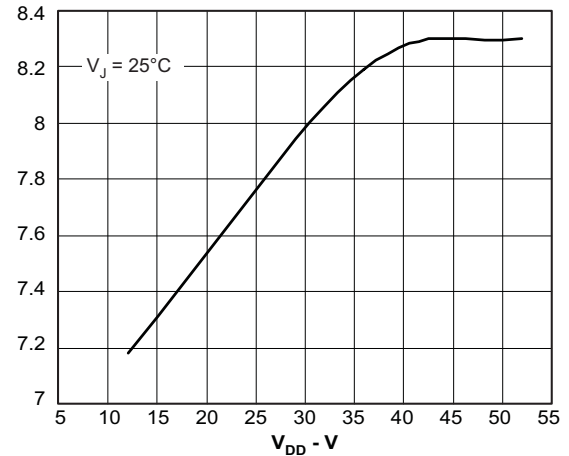

Figure 18. Gate Drive Voltage vs VIN

Typical Characteristics (continued)

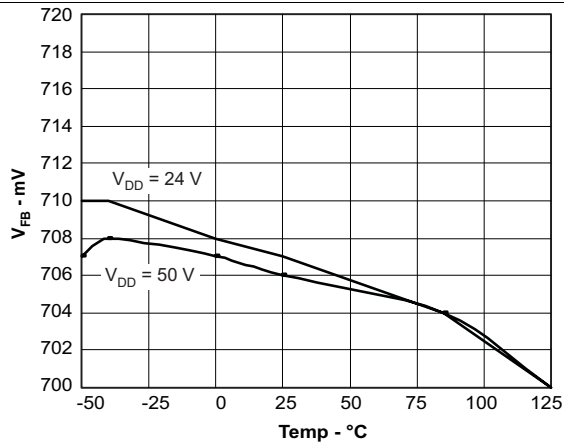

Figure 19. Reference Voltage vs Temperature

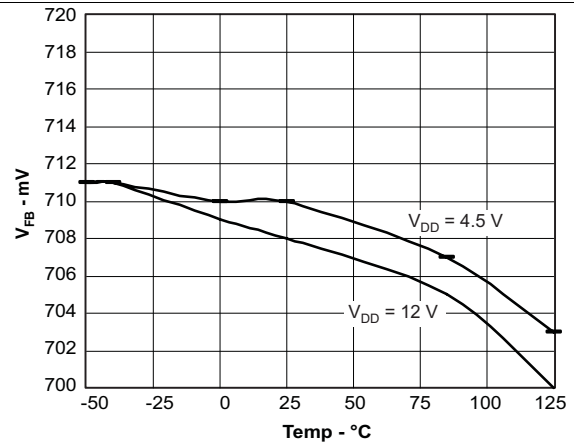

Figure 20. Reference Voltage vs Temperature

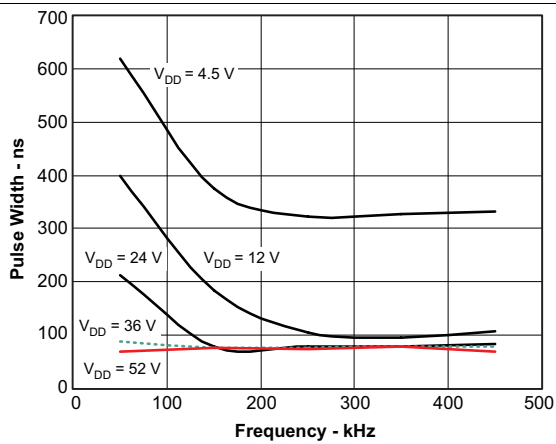

Figure 21. Minimum Controllable Pulse Width vs Frequency

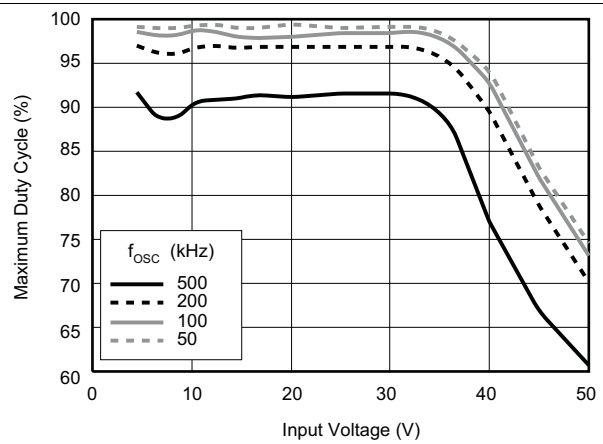

Figure 22. Maximum Duty Cycle vs Input Voltage

## 7 Detailed Description

### 7.1 Overview

The TPS40200 is a non-synchronous controller with a built in 200-mA driver designed to drive high speed P-channel FETs up to 500 kHz. Small size combined with complete functionality makes the part both versatile and easy to use.

The controller uses a low-value current-sensing resistor in series with the input voltage and the power FETs source connection to detect switching current. When the voltage drop across this resistor exceeds 100 mV, the part enters an hiccup fault mode at about 2% of the operating frequency.

The device uses voltage feedback to an error amplifier that is biased by a precision 700-mV reference. Feed-forward compensation from the input keeps the PWM gain constant over the full input voltage range, eliminating the need to change frequency compensation for different input voltages.

The TPS40200 also incorporates a soft-start feature where the output follows a slowly rising soft-start voltage, preventing output-voltage overshoot.

### 7.2 Functional Block Diagram

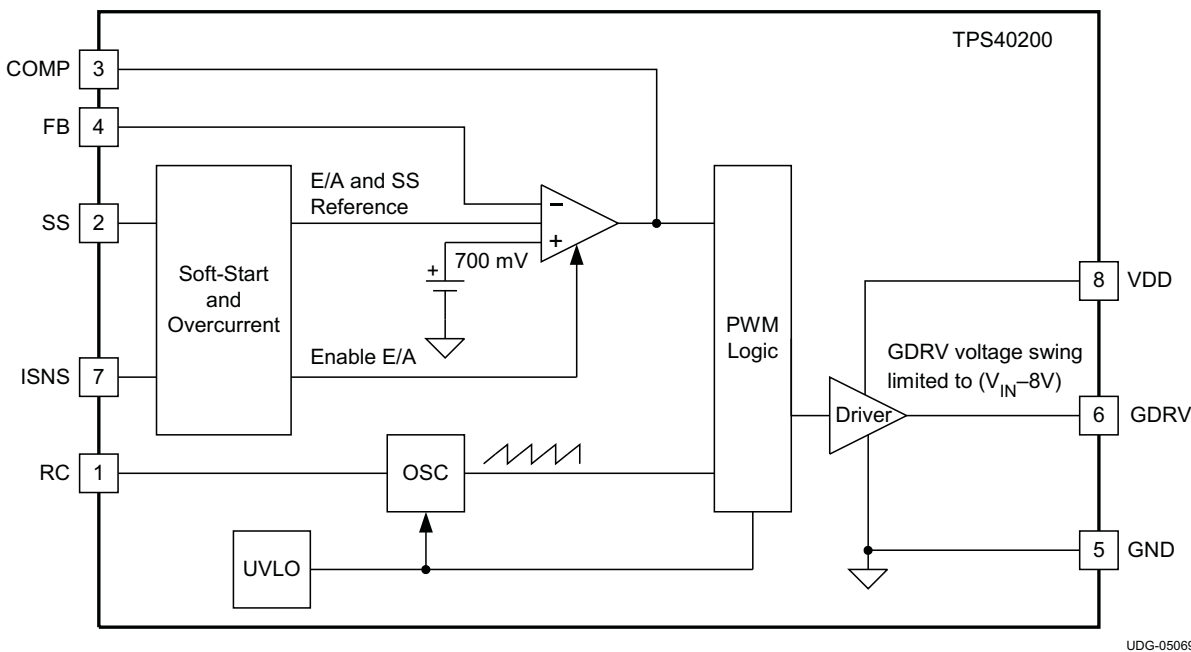

### 7.3 Feature Description

#### 7.3.1 MOSFET Gate Drive

The output driver sinking current is approximately 200 mA and is designed to drive P-channel power FETs. When the driver pulls the gate charge of the FET it is controlling to 8 V, the drive current folds back to a low level so that high-power dissipation only occurs during the turn-on period of the FET. This feature is particularly valuable when turning on a FET at high input voltages where leaving the gate drive current on would otherwise cause unacceptable power dissipation.

#### 7.3.2 Undervoltage Lockout Protection

Undervoltage lockout (UVLO) protection ensures proper startup of the device only when the input voltage has exceeded minimum operating voltage. Undervoltage protection incorporates hysteresis which eliminates hiccup starting in cases where input supply impedance is high.

## Feature Description (continued)

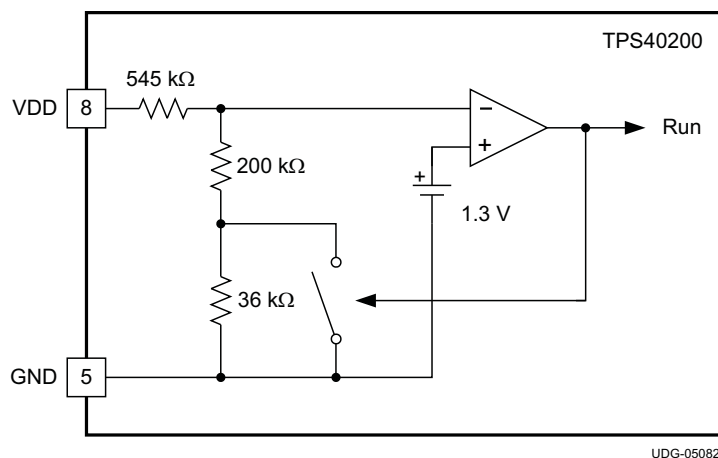

**Figure 23. Undervoltage Lockout**

Undervoltage protection ensures proper startup of the device only when the input voltage has exceeded minimum operating voltage. The UVLO level is measured at the VDD pin with respect to GND. Startup voltage is typically 4.3 V with approximately 200 mV of hysteresis. The device shuts off at a nominal 4.1 V. As shown in [Figure 23](#), when the input  $V_{DD}$  voltage rises to 4.3 V, the 1.3-V comparator's threshold voltage is exceeded and a RUN signal occurs. Feedback from the output closes the switch, and shunts the 200-kΩ resistor so that an approximately 200 mV lower voltage, or 4.1 V, is required before the part shuts down.

### 7.3.3 Selecting the Operating Frequency

The operating frequency of the controller is determined by an external resistor  $R_{RC}$  that is connected from the RC pin to VDD and a capacitor attached from the RC pin to ground. This connection and the two oscillator comparators inside the device, are shown in [Figure 24](#). The oscillator frequency can be calculated in [Equation 1](#).

$$f_{SW} = \frac{1}{R_{RC} \times C_{RC} \times 0.105} \quad (1)$$

where

$f_{SW}$  is the clock frequency

$R_{RC}$  is the timing resistor value in  $\Omega$

$C_{RC}$  is the timing capacitor value in F

$R_{RC}$  must be kept large enough that the current through it does not exceed 750  $\mu$ A when the internal switch (shown in [Figure 24](#)) is discharging the timing capacitor. This condition may be expressed by [Equation 2](#).

$$\frac{V_{IN}}{R_{RC}} \leq 750 \mu\text{A} \quad (2)$$

### 7.3.4 Synchronizing the Oscillator

[Figure 24](#) shows the functional diagram of the oscillator. When synchronizing the oscillator to an external clock, the RC pin must be pulled below 150 mV for 20 ns or more. The external clock frequency must be higher than the free running frequency of the converter as well. When synchronizing the controller, if the RC pin is held low for an excessive amount of time, erratic operation may occur. The maximum amount of time that the RC pin should be held low is 50% of a nominal output pulse, or 10% of the period of the synchronization frequency whichever is less.

### Feature Description (continued)

Under circumstances where the input voltage is high and the duty cycle is less than 50%, a Schottky diode connected from the RC pin to an external clock may be used to synchronize the oscillator. The cathode of the diode is connected to the RC pin. The trip point of the oscillator is set by an internal voltage divider to be 1/10 of the input voltage. The clock signal must have an amplitude higher than this trip point. When the clock goes low, it allows the reset current to restart the RC ramp, synchronizing the oscillator to the external clock. This provides a simple, single-component method for clock synchronization.

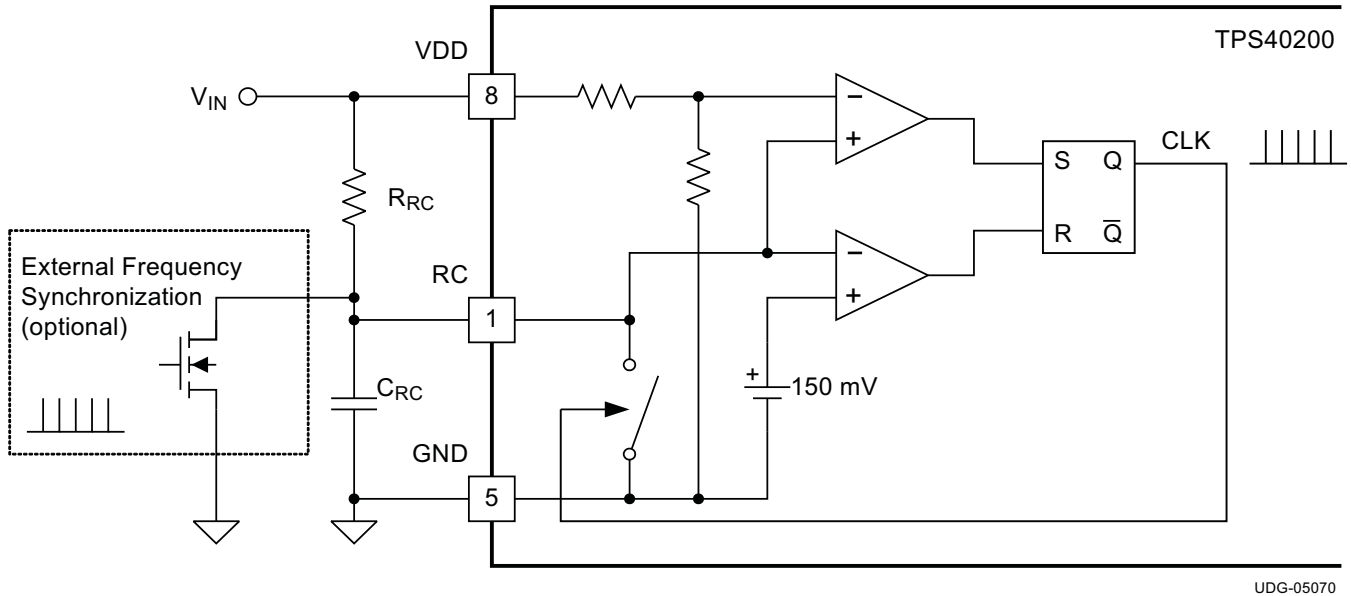

Figure 24. Oscillator Functional Diagram

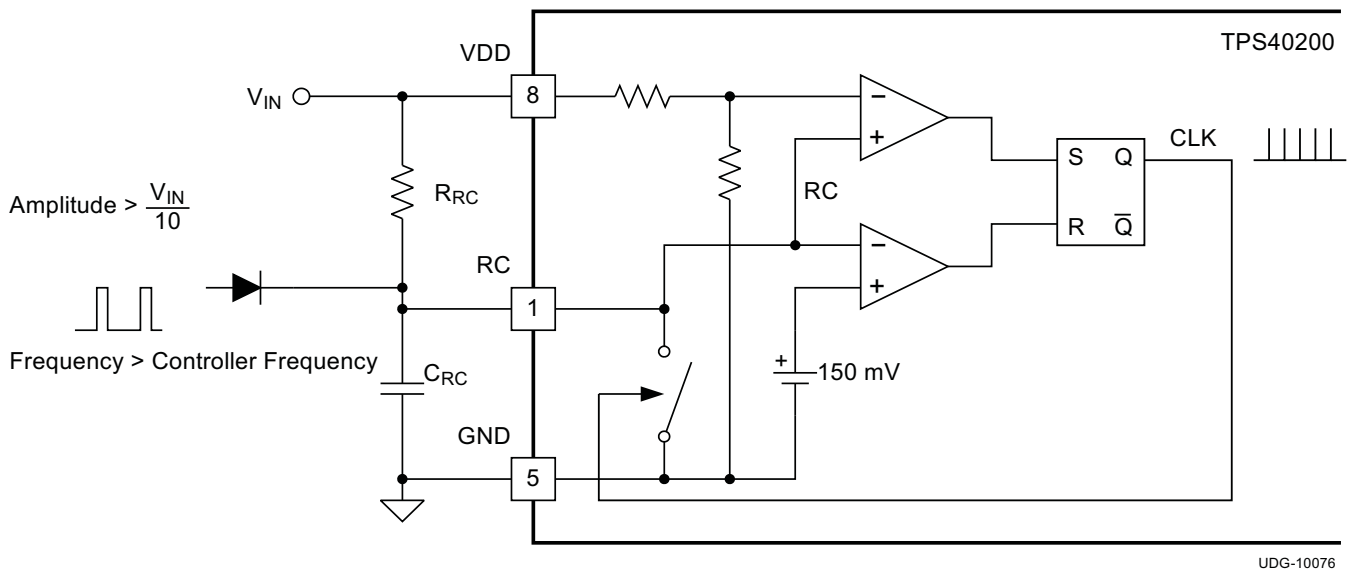
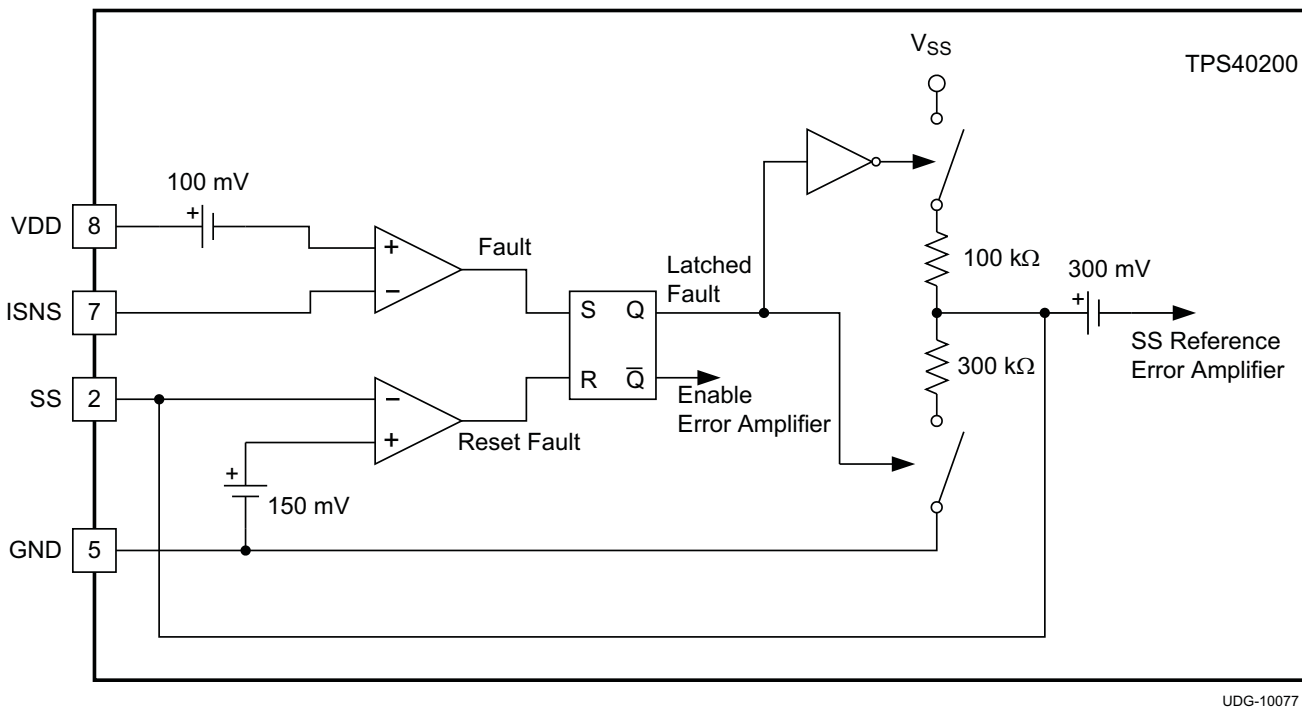

Figure 25. Diode-Connected Synchronization

## Feature Description (continued)

### 7.3.5 Current Limit Resistor Selection

As shown in [Figure 28](#), a resistor in series with the power MOSFET sets the overcurrent protection level. Use a low-inductance resistor to avoid ringing signals and nuisance tripping. When the FET is on and the controller senses 100 mV or more drop from the VDD pin to the ISNS pin, an overcurrent condition is declared. When this happens, the FET is turned off, and as shown in [Figure 26](#), the soft-start capacitor is discharged. When the soft-start capacitor reaches a level below 150 mV, the converter clears the overcurrent condition flag and attempts to restart. If the condition that caused the overcurrent event to occur is still present on the output of the converter (see [Figure 27](#)), another overcurrent condition is declared and the process repeats indefinitely. [Figure 27](#) shows the soft-start capacitor voltage during an extended output fault condition. The overall duty cycle of current conduction during a persistent fault is approximately 2%.



**Figure 26. Current Limit Reset**

**Feature Description (continued)**

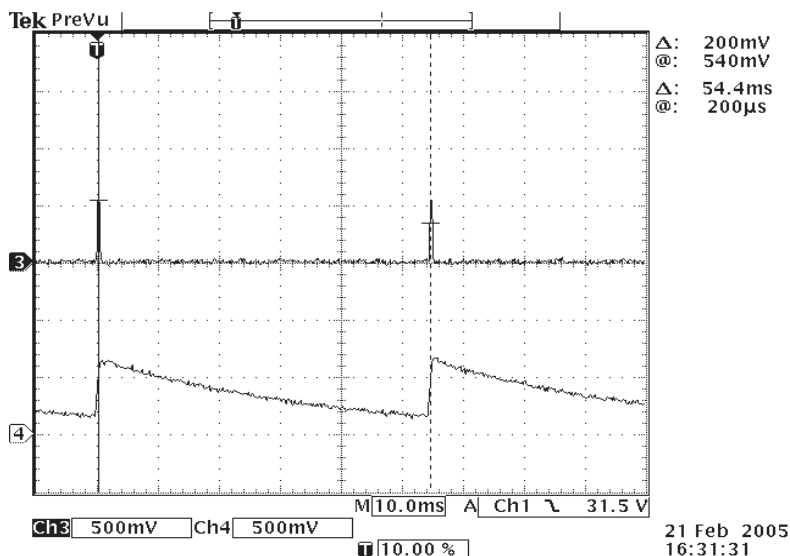

**Figure 27. Typical Soft-Start Capacitor and V<sub>OUT</sub> During Overcurrent**

If necessary, a small RC filter can be added to the current sensing network to reduce nuisance tripping due to noise pickup. This filter can also be used to trim the overcurrent trip point to a higher level with the addition of a single resistor. See [Figure 28](#). The nominal overcurrent trip point using the circuit of [Figure 28](#) is described in [Equation 3](#).

$$I_{OC} = \frac{V_{ILIM}}{R_{ILIM}} \times \frac{R_{F1} + R_{F2}}{R_{F2}} \tag{3}$$

Where

- I<sub>OC</sub> is the overcurrent trip point, peak current in the inductor
- V<sub>ILIM</sub> is the overcurrent threshold voltage for the TPS40200, typically 100 mV
- R<sub>ILIM</sub> is the value of the current sense resistor in Ω
- R<sub>F1</sub> and R<sub>F2</sub> are the values of the scaling resistors in Ω

The value of the capacitor is determined by the nominal pulse width of the converter and the values of the scaling resistors R<sub>F1</sub> and R<sub>F2</sub>. It is best not to have the time constant of the filter longer than the nominal pulse width of the converter, otherwise a substantial increase in the overcurrent trip point occurs. Using this constraint, the capacitor value may be bounded by [Equation 4](#).

$$C_F \leq \frac{\left( \frac{V_{OUT}}{V_{IN} \times f_{SW}} \right)}{\frac{(R_{F1} \times R_{F2})}{(R_{F1} + R_{F2})}} \tag{4}$$

Where

- C<sub>F</sub> is the value of the current limit filter capacitor in F
- V<sub>OUT</sub> is the output voltage of the converter
- V<sub>IN</sub> is the input voltage to the converter
- f<sub>SW</sub> is the converter switching frequency
- R<sub>F1</sub> and R<sub>F2</sub> are the values of the scaling resistors in Ω

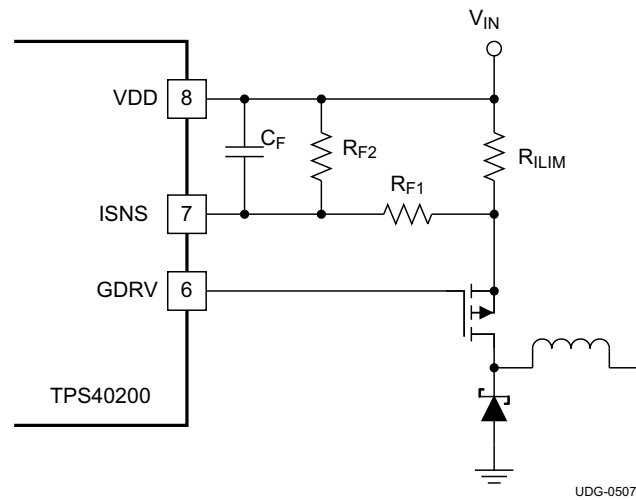
**Feature Description (continued)**

**Figure 28. Current Limit Adjustment**
**NOTE**

The current limit resistor and its associated circuitry can be eliminated and the ISNS pin (pin 7) and the VDD pin (pin 8) are shorted. The result of this however, may result in damage to the device or PC board during an overcurrent event.



## Feature Description (continued)

### 7.3.6 Calculating the Soft-Start Time

An external capacitor  $C_{SS}$ , connected from the SS pin to ground, controls the soft-start interval. An internal charging resistor connected to  $V_{DD}$  produces a rising reference voltage which is connected through a 700-mV offset to the reference input of the TPS40200 error amplifier. When the soft-start capacitor voltage ( $V_{CSS}$ ) is below 150 mV, there is no switching activity. When  $V_{CSS}$  rises above the 700 mV offset, the error amplifier starts to follow  $V_{SST} - 700$  mV, and uses this rising voltage as a reference. When  $V_{CSS}$  reaches 1.4 V, the internal reference takes over, and further increases have no effect. An advantage of initiating a slow start in this fashion is that the controller cannot overshoot because its output follows a scaled version of the controller reference voltage. A conceptual drawing of the circuit that produces these results is shown in Figure 29. A consequence of the 700 mV offset is that the controller does not start switching until  $V_{CSS}$  has risen to 700 mV. The output remains at 0 V during the resulting delay. When  $V_{CSS}$  exceeds the 700 mV offset, the TPS40200 output follows the soft-start time constant. Once above 1.4 V, the 700-mV internal reference takes over, and normal operation begins.

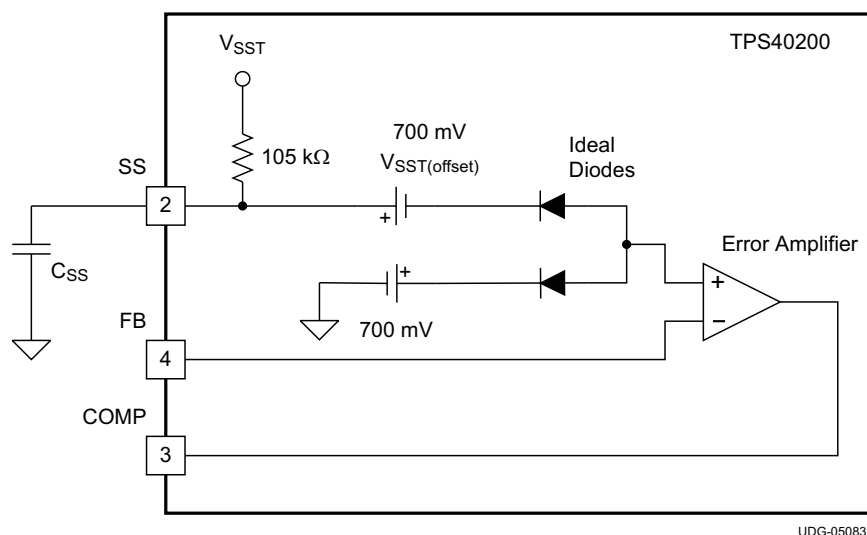

Figure 29. Soft-Start Circuit

The slow-start time should be longer (slower) than the time constant of the output LC filter. This time constraint may be expressed as described in Equation 5.

$$t_S \geq 2\pi \times \sqrt{L_{OUT} \times C_{OUT}} \quad (5)$$

The calculation of the soft-start interval is simply the time it takes the RC network to exponentially charge from 0 V to 1.4 V. An internal 105 kΩ charging resistor is connected from the SS pin to  $V_{SST}$ . For applications where the voltage is above 8 V, an internal regulator clamps the maximum charging voltage to 8 V.

The result of this is a formula for the start-up time, as shown in Equation 6.

$$t_{SS} = R_C \times C_{SS} \times \ln \left( \frac{V_{SST}}{V_{SST} - 1.4} \right) \quad (6)$$

Where

- $t_{SS}$  is the required soft-start time in seconds
- $C_{SS}$  is the soft-start capacitor value in F
- $R_C$  is the internal soft-start charging resistor (105 kΩ nominal)
- $V_{SST}$  is the input voltage up to a maximum of 8 V

## Feature Description (continued)

### 7.3.7 Voltage Setting and Modulator Gain

Since the input current to the error amplifier is negligible, the feedback impedance can be selected over a wide range. Knowing that the reference voltage is 696 mV, choose a convenient value for R1 and then calculate the value of R2 from Equation 7.

$$V_{OUT} = 0.696 \times \left( 1 + \frac{R2}{R1} \right) \quad (7)$$

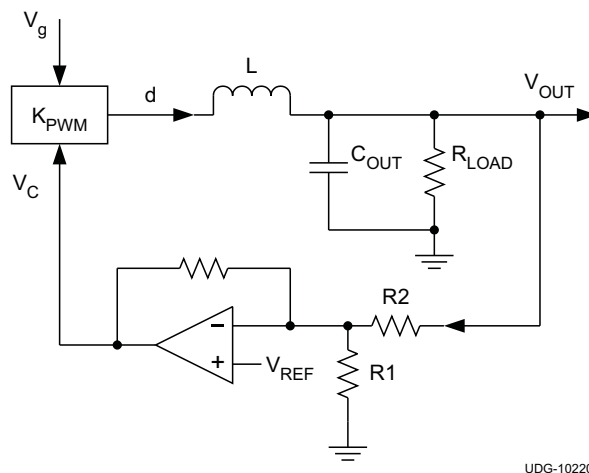

**Figure 30. System Gain Elements**

The error amplifier has a DC open loop gain of at least 60 dB with a minimum of a 1.5-MHz gain bandwidth product which gives the user flexibility with respect to the type of feedback compensation he uses for his particular application. The gain selected by the user at the crossover frequency is set to provide an over all unity gain for the system. The crossover frequency should be selected so that the error amplifier open-loop gain is high with respect to the required closed-loop gain, ensuring that the amplifier response is determined by the passive feedback elements.

## 7.4 Device Functional Modes

### 7.4.1 Operation Near Minimum Input Voltage

The TPS40200 is designed to operate with input voltages above 4.5 V. The typical V<sub>DD</sub> UVLO threshold is 4.25 V and the device may operate at input voltages down to the UVLO voltage. At input voltages below the actual UVLO voltage, the device will not switch. When V<sub>VDD</sub> passes the UVLO threshold the device will become active. Switching is enabled and the soft start sequence is initiated. The TPS40200 will ramp up the output voltage at the rate determined by the external capacitor at the soft-start pin.

### 7.4.2 Operation With SS Pin

The SS pin has a 150 mV threshold which can be used to disable the TPS40200. With SS forced below this threshold voltage the device is disabled and switching is inhibited even if V<sub>VDD</sub> is above its UVLO threshold. If the SS voltage is allowed to increase above the threshold while V<sub>VDD</sub> is above its UVLO threshold, the device becomes active. Switching is enabled and the soft start sequence is initiated. The TPS40200 will ramp up the output voltage at the rate determined by the external capacitor at the soft-start pin.

## 8 Application and Implementation

### NOTE

Information in the following applications sections is not part of the TI component specification, and TI does not warrant its accuracy or completeness. TI's customers are responsible for determining suitability of components for their purposes. Customers should validate and test their design implementation to confirm system functionality.

### 8.1 Application Information

The TPS40200 is a 4.5-V to 52-V buck controller with an integrated gate driver for a high-side p-channel MOSFET. This device is typically used to convert a higher DC voltage to a lower DC voltage with a maximum output current set by an external current sense resistor. In higher current applications, the maximum output current can also be limited by the thermal performance of the external MOSFET and rectifying diode switch. Use the following design procedure to select external components for the TPS40200. The design procedure illustrates the design of a typical buck regulator with the TPS40200.

### 8.2 Typical Application

#### 8.2.1 Buck Regulator, 8 V to 12 V Input, 3.3 V to 5.0 V at 2.5-A Output

The buck regulator design shown in Figure 31 shows the use of the TPS40200. It delivers 2.5 A at either 3.3 V or 5.0 V as selected by a single feedback resistor. It achieves approximately 90% efficiency at 3.3 V and 94% at 5.0 V. A discussion of design tradeoffs and methodology is included to serve as a guide to the successful design of buck converters using the TPS40200.

The Bill of Materials for this application is given in Table 2. The efficiency and load regulation from boards built from this design are shown in Figure 42 and Figure 43.

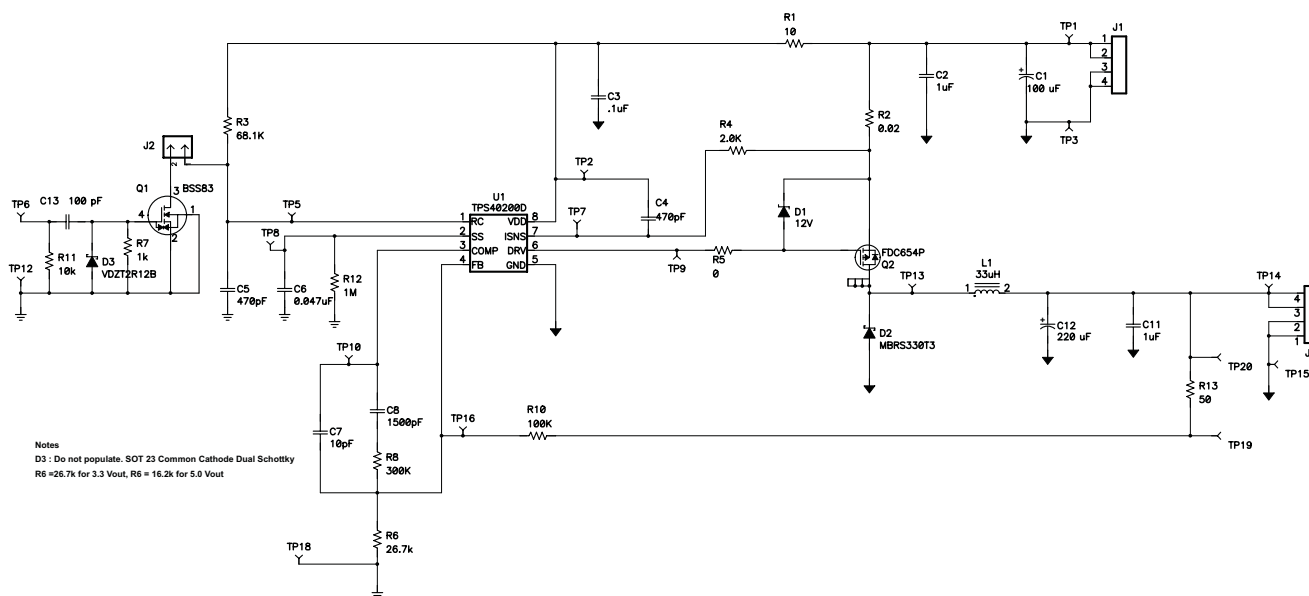

Figure 31. 8 V to 16 V<sub>IN</sub> Step-Down Buck Converter

## Typical Application (continued)

### 8.2.1.1 Design Requirements

**Table 1. Design Parameters**

PARAMETER		TEST CONDITION	MIN	NOM	MAX	UNIT
V <sub>IN</sub>	Input Voltage		8	12	16	V
V <sub>OUT</sub>	Output Voltage	I <sub>OUT</sub> = 2.5 A	3.2	3.3	3.4 <sup>(1)</sup>	V
	Line Regulation	± 0.2 % V <sub>OUT</sub>	3.293	3.300	3.307	V
	Load Regulation	± 0.2% V <sub>OUT</sub>	3.293	3.300	3.307	V
V <sub>OUT</sub>	Output Voltage	I <sub>OUT</sub> at 2.5 A	4.85	5.0	5.150 <sup>(1)</sup>	V
	Line Regulation	± 0.2% × V <sub>OUT</sub>	4.99	5.00	5.01	V
	Load Regulation	± 0.2% × V <sub>OUT</sub>	4.99	5.00	5.01	V
V <sub>RIPPLE</sub>	Output ripple voltage	At maximum output current		60		mV
V <sub>OVER</sub>	Output overshoot	For 2.5 A load transient from 2.5 A to 0.25 A		100		mV
V <sub>UNDER</sub>	Output undershoot	For 2.5 A load transient from 0.25 A to 2.5 A		60		mV
I <sub>OUT</sub>	Output Current		0.125		2.500	A
I <sub>SCP</sub>	Short circuit current trip point		3.75		5.00	A
	Efficiency	At nominal input voltage and maximum output current		90%		
F <sub>S</sub>	Switching frequency			300		kHz

(1) Set point accuracy is dependent on external resistor tolerance and the device reference voltage. Line and Load regulation values are referenced to the nominal design output voltage.

### 8.2.1.2 Detailed Design Procedure

#### 8.2.1.2.1 FET Selection Criteria

- The maximum input voltage for this application is 16 V. Switching the inductor causes overshoot voltages that can equal the input voltage. Since the R<sub>DS(on)</sub> of the FET rises with breakdown voltage, select a FET with as low a breakdown voltage as possible. In this case, a 30-V FET was selected.
- The selection of a power FET size requires knowing both the switching losses and DC losses in the application. AC losses are all frequency dependent and directly related to device capacitances and device size. On the other hand, DC losses are inversely related to device size. The result is an optimum where the two types of losses are equal. Since device size is proportional to R<sub>DS(on)</sub>, begin by selecting a device with an R<sub>DS(on)</sub> that results in a small loss of power relative to package thermal capability and overall efficiency objectives.
- In this application, the efficiency target is 90% and the output power 8.25 W. This gives a total power-loss budget of 0.916 W. Total FET losses must be small relative to this number.

The DC conduction loss in the FET is given by:  $P_{DC} = I_{rms}^2 \times R_{DS(on)}$

The RMS current is given by:

$$I_{RMS} = \left( D \times \left( I_{OUT}^2 + \frac{(\Delta I_{P-P})^2}{12} \right) \right)^{\frac{1}{2}} \quad (8)$$

Where

$$\Delta I_{P-P} = \Delta V \times D \times \frac{t_s}{L_I}$$

$$\Delta V = V_{IN} - V_{OUT} - (DCR + R_{DS(on)}) \times I_{OUT}$$

R<sub>DS(on)</sub> is the FET on-state resistance

DCR is the inductor DC resistance

D is the duty cycle

t<sub>s</sub> = the reciprocal of the switching frequency

Using the values in this example, the DC power loss is 129 mW. The remaining FET losses are as follows:

- $P_{SW}$  is the power dissipated while switching the FET on and off
- $P_{GATE}$  is the power dissipated driving the FET gate capacitance
- $P_{COSS}$  is the power switching the FET output capacitance

The total power dissipated by the FET is the sum of these contributions.

$$P_{FET} = P_{SW} + P_{GATE} + P_{COSS} + P_{RDS(on)} \quad (9)$$

The P-channel FET used in this application is a FDC654P with the following characteristics:

$$\begin{aligned} t_{RISE} &= 13 \times 10^{-9} & C_{OSS} &= 83 \times 10^{-12} \\ t_{FALL} &= 6 \times 10^{-9} & Q_G &= 9 \text{ nC} \\ R_{DS(on)} &= 0.1 \Omega & V_{GATE} &= 1.9 \text{ V} \\ Q_{GD} &= 1.2 \times 10^{-9} & Q_{GS} &= 1.0 \times 10^{-9} \end{aligned}$$

Using these device characteristics and [Equation 10](#):

$$P_{SW} = \frac{f_S}{2} \times \left( V_{IN} \times I_{pk} \times t_{CHON} \right) + \frac{f_S}{2} \left( V_{IN} \times I_{pk} \times t_{CHOFF} \right) = 10 \text{ mW} \quad (10)$$

where  $t_{CH(on)} = \frac{Q_{GD} \times R_G}{V_{IN} - V_{TH}}$  and  $t_{CH(off)} = \frac{Q_{GD} \times R_G}{V_{IN}}$  are the switching times for the power FET.

$$P_{GATE} = Q_G \times V_{GATE} \times f_S = 22 \text{ mW} \quad (11)$$

$$P_{CROSS} = \frac{C_{OSS} \times V_{IN\_MAX}^2 \times f_S}{2} = 2 \text{ mW} \quad (12)$$

The gate current,  $I_G = Q_G \times f_S = 2.7 \text{ mA}$

The sum of the switching losses is 34 mW, and is comparable to the 129-mW DC losses. At added expense, a slightly larger FET is better because the DC loss drops and the AC losses increase, with both moving toward the optimum point of equal losses.

#### 8.2.1.2.2 Rectifier Selection Criteria

##### 1. Rectifier Breakdown Voltage

The rectifier has to withstand the maximum input voltage which in this case is 16 V. To allow for switching transients which can approach the switching voltage a 30-V rectifier was selected.

##### 2. Diode Size

The importance of power losses from the Schottky rectifier D2 is determined by the duty cycle. For a low duty cycle application, the rectifier is conducting most of the time, and the current that flows through it times its forward drop can be the largest component of loss in the entire controller. In this application, the duty cycle ranges from 20% to 40%, which in the worst case means that the diode is conducting 80% of the time. Where efficiency is of paramount importance, choose a diode with a minimum of forward drop. In more cost sensitive applications, size may be reduced to the point of the thermal limitations of the diode package.

The device in this application is large relative to the current required by the application. In a more cost sensitive application, a smaller diode in a less-expensive package will provide a less-efficient but appropriate solution

The device used has the following characteristics:

- $V_f = 0.3 \text{ V}$  at 3 A
- $C_t = 300 \text{ pF}$  ( $C_t$  = the effective reverse voltage capacitance of the synchronous rectifier, D2).

The two components of the losses from the diode D2 are:

$$P_{\text{COND}} = V_f \times \left( I_{\text{OUT}} + \frac{I_{\text{RIPPLE}}}{4} \right) \times (1-D) = 653 \text{ mW} \quad (13)$$

Where

D = the duty cycle

$I_{\text{RIPPLE}}$  is the ripple current

$I_{\text{OUT}}$  is the output current

$V_f$  is the forward voltage

$P_{\text{COND}}$  is the conduction power loss

The switching capacitance of this diode adds an AC loss, given by:

$$P_{\text{SW}} = \frac{1}{2} \left[ C \times (V_{\text{IN}} + V_f)^2 \times f \right] = 6.8 \text{ mW} \quad (14)$$

This additional loss raises the total loss to: 660 mW.

At an output voltage of 3.3 V, the application runs at a nominal duty cycle of 27%, and the diode is conducting 72.5% of the time. As the output voltage is moved up to 5 V, the on-time increases to 46% and the diode is conducting only 54% of the time during each clock cycle. This change in duty cycle proportionately reduces the conduction power losses in the diode. This reduction may be expressed as

$$660 \left( \frac{0.54}{0.725} \right) = 491 \text{ mW} \quad \text{for a savings in power of } 660 - 491 = 169 \text{ mW}.$$

To illustrate the relevance of this power savings we measured the full load module Efficiency for this application at 3.3 V and 5 V. The 5-V output efficiency is 92% vs. 89% for the 3.3 V design. This difference in efficiency represents a 456 mW reduction in losses between the two conditions. This 169 mW power-loss reduction in the rectifier represents 37% of the difference.

### 8.2.1.2.3 Inductor Selection Criteria

The P-channel FET driver facilitates switching the power FET at a high frequency. This, in turn, enables the use of smaller, less-expensive inductors as illustrated in this 300 kHz application. Ferrite, with its good high frequency properties, is the material of choice. Several manufacturers provide catalogs with inductor saturation currents, inductance values, and LSRs (internal resistance) for their various-sized ferrites.

In this application, the device must deliver a maximum current of 2.5 A. This requires that the output inductor's saturation current be above 2.5 A plus ½ the ripple current caused during inductor switching. The value of the inductor determines this ripple current. A low value of inductance has a higher ripple current that contributes to ripple voltage across the resistance of the output capacitors. The advantages of a low inductance are a higher transient response, lower DCR, a higher saturation current, and a smaller, less expensive part. Too low an inductor however, leads to higher peak currents which ultimately are bounded by the overcurrent limit set to protect the output FET or by output ripple voltage. Fortunately, with low ESR Ceramic capacitors on the output, the resulting ripple voltage for relatively high ripple currents can be small.

For example, a single 1- $\mu$ F, 1206 size, 6.3-V, ceramic capacitor has an internal resistance of 2  $\Omega$  at 1 MHz. For this 2.5-A application, a 10% ripple current of 0.25 A produces a 50-mV ripple voltage. This ripple voltage may be further reduced by additional parallel capacitors.

The other bound on inductance is the minimum current at which the controller enters discontinuous conduction. At this point, Inductor current is zero. The minimum output current for this application is specified at 0.125 A. This average current is 1/2 the peak current that must develop during a minimum on time. The conditions for minimum on time are high line and low load.

Using:

$$L_{\text{MIN}} = \frac{V_{\text{IN}} - V_{\text{OUT}}}{I_{\text{PEAK}}} \times t_{\text{on}} = 32 \text{ } \mu\text{H} \quad (15)$$

Where

$V_{\text{IN}} = 16 \text{ V}$

$V_{\text{OUT}} = 3.3 \text{ V}$

$I_{\text{PEAK}} = 0.25 \text{ A}$

$$t_{ON} = 0.686 \mu\text{s}$$

$$t_{ON} \text{ is given by } \frac{1}{300 \text{ kHz}} \times \frac{3.3 \text{ V}}{16 \text{ V}}$$

The inductor used in the circuit is the closest standard value of 33  $\mu\text{H}$ . This is the minimum inductance that can be used in the converter to deliver the minimum current while maintaining continuous conduction.

#### 8.2.1.2.4 Output Capacitance

In order to satisfy the output voltage over and under shoot specifications there must be enough output capacitance to keep the output voltage within the specified voltage limits during load current steps.

In a situation where a full load of 2.5 A within the specified voltage limits is suddenly removed, the output capacitor must absorb energy stored in the output inductor. This condition may be described by realizing that the energy in the stored in the inductor must be suddenly absorbed by the output capacitance. This energy relationship is written as:

$$\frac{1}{2} \times L_O I_O^2 \leq \frac{1}{2} \times [C_O (V_{OS}^2 - V_O^2)] \quad (16)$$

Where

$V_{OS}$  is the allowed over-shoot voltage above the output voltage

$L_O$  is the inductance

$I_O$  is the output current

$C_O$  is the output capacitance

$V_O$  is the output voltage

In this application, the worst case load step is 2.25 A and the allowed overshoot is 100 mV. With a 33  $\mu\text{H}$  output inductor, this implies an output capacitance of 249  $\mu\text{F}$  for a 3.3 V output and 165  $\mu\text{F}$  for a 5 V output..

When the load increases from minimum to full load the output capacitor must deliver current to the load. The worst case is for a minimum on time that occurs at 16 V in and 3.3  $V_{OUT}$  and minimum load. This corresponds to an off time of  $(1 - 0.2)$  times the period 3.3  $\mu\text{s}$  and is the worst case time before the inductor can start supplying current. This situation may be represented by:

$$\Delta V_O < \Delta I_O \times \frac{t_{OFFMAX}}{C_O} \quad (17)$$

Where

$\Delta V_O$  is the undershoot specification of 60 mV

$\Delta I_O$  is the load current step

$t_{OFF(max)}$  is the maximum off time

This condition produces a requirement of 100  $\mu\text{F}$  for the output capacitance. The larger of these two requirements becomes the minimum value of output capacitance.

The ripple current develops a voltage across the ESR of the output capacitance, so another requirement on this component is it ESR be small relative to the ripple voltage specification.

#### 8.2.1.2.5 Switching Frequency

The TPS40200 has a built-in, 8-V, 200-mA, P-channel FET driver output that facilitates using P-channel switching FETs. A clock frequency of 300 kHz is chosen as a switching frequency that represents a compromise between a high-frequency that allows the use of smaller capacitors and inductors but one that is not so high as to cause excessive transistor switching losses. As previously discussed, an optimum frequency can be selected by picking a value where the DC and switching losses are equal.

The frequency is set by using the design formula given in the [FET Selection Criteria](#) section.

$$R_{RC} \times C_{RC} = \frac{1}{0.105 \times f_{SW}} \quad (18)$$

Where

$R_{RC}$  is the timing resistor value in  $\Omega$   
 $R_{RC} = 68.1 \text{ k}\Omega$   
 $C_{RC}$  is the timing capacitor value in F  
 $C_5 = 470 \text{ pF}$   
 $f_{SW}$  is the desired switching frequency in Hz  
 $f_{SW} = 297 \text{ kHz}$ .

At a worst case of 16 V, the timing resistor draws about 250  $\mu\text{A}$  which is well below the 750  $\mu\text{A}$  maximum which the circuit can pull down.

### 8.2.1.2.6 Calculating the Overcurrent Threshold Level

The current limit in the TSP40200 is triggered by a comparator with a 100-mV offset whose inputs are connected across a current-sense resistor between  $V_{IN}$  and the source of the high-side switching FET. When current in this resistor develops more than 100 mV, the comparator trips and terminates the output gate drive.

In this application, the current-limit resistor is set by the peak output stage current which consists of the maximum load current plus  $\frac{1}{2}$  the ripple current. In this case, we have  $2.5 + 0.125 = 2.625 \text{ A}$ . To accommodate tolerances a 25% margin is added giving a 3.25 A peak current. Using the equation below then yields a value for  $R_{ILIM}$  of 0.03  $\Omega$ .

Current sensing in a switching environment requires attention to both circuit board traces and noise pick up. In the design shown a small RC filter has been added to the circuit to prevent switching noise from tripping the current sense comparator. The requirements of this filter are board-dependent, but with the layout used in this application, no unreasonable overcurrent is observed.

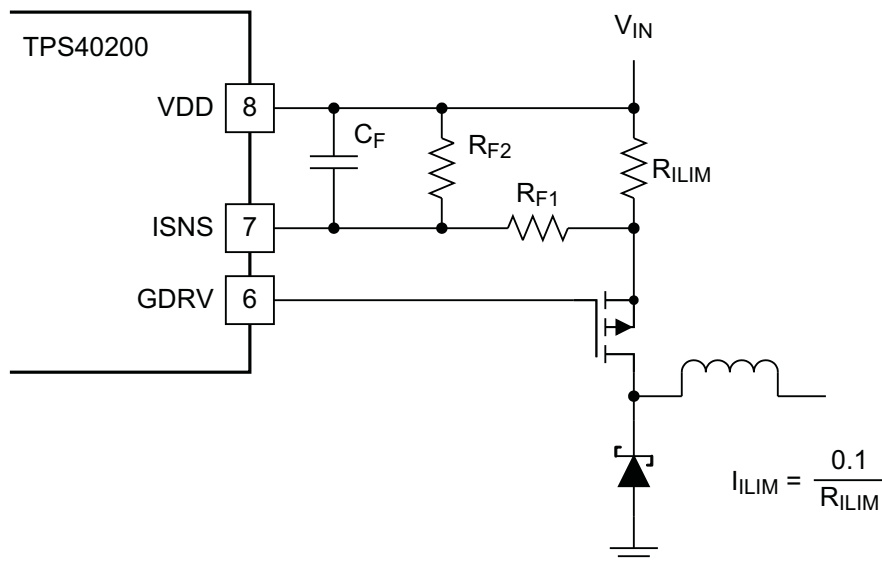

UDG-11200

**Figure 32. Overcurrent Trip Circuit for  $R_{F2}$  Open**



**8.2.1.2.7 Soft-Start Capacitor**

The soft-start interval is given (in pF) by the following equation:

$$C_{SS} = \frac{t_{SS}}{R \times \ln\left(\frac{V_{SST}}{V_{SST} - 1.4}\right)} \times 10^3 \tag{19}$$

Where

R is an internal 105-kΩ charging resistor

V<sub>IN</sub> is the input voltage up to 8 V where the charging voltage is internally clamped to 8 V maximum

V<sub>OS</sub> = 700 mV, and because the input voltage is 12 V, V<sub>SST</sub> = 8 V.

The oscilloscope picture below shows the expected delay at the output (middle trace) until the soft-start node (bottom trace) reaches 700 mV. At this point, the output rises following the exponential rise of the soft-start capacitor voltage until the soft-start capacitor reaches 1.4 V and the internal 700-mV reference takes over. This total time is approximately 1 ms, which agrees with the calculated value of 0.95 ms where the soft-start capacitance is 0.047 μF.

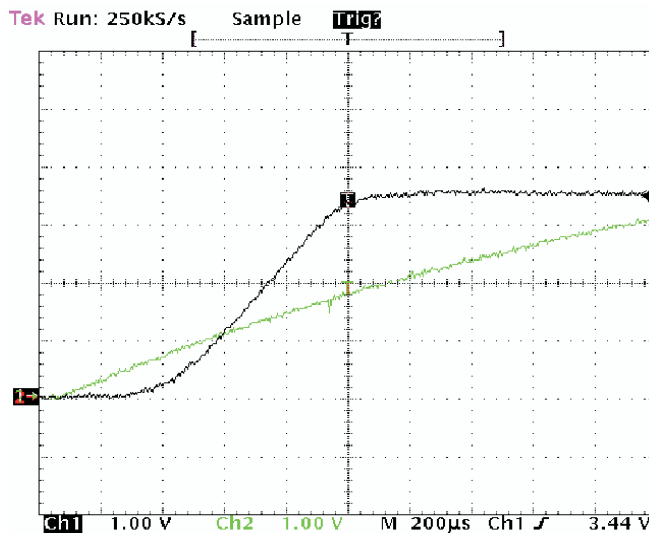

- A. Channel 1 is the output voltage (V<sub>OUT</sub>) rising to 3.3 V
- B. Channel 2 is the soft start pin (SS)

**Figure 33. Soft-Start Showing Output Delay and Controlled Rise to Programmed Output Voltage**

### 8.2.1.2.8 Frequency Compensation

The four elements that determine the system overall response are discussed below. The gain of the error amplifier ( $K_{EA}$ ) is the first of these elements. Its output develops a control voltage which is the input to the PWM.

The TPS40200 has a unique modulator that scales the peak to peak amplitude of the PWM ramp to be 0.1 times the value of the input voltage. Since modulator gain is given by  $V_{IN}$  divided by  $V_{RAMP}$ , the modulator gain is 10 and is constant at 10 (20 dB) over the entire specified input voltage range.

The last two elements that affect system gain are the transfer characteristic of the output LC filter and the feedback network from the output to the input to the error amplifier.

These four elements may be expressed by the following expression that represents the system transfer function as shown in [Figure 34](#).

$$T_V(s) = K_{FB} \times K_{EA}(s) \times K_{PWM} \times X_{LC}(s) \quad (20)$$

Where

$K_{FB}$  is the output voltage setting divider

$K_{EA}$  is the error amplifier feedback

$K_{PWM}$  is the modulator gain

$X_{LC}$  is the filter transfer function

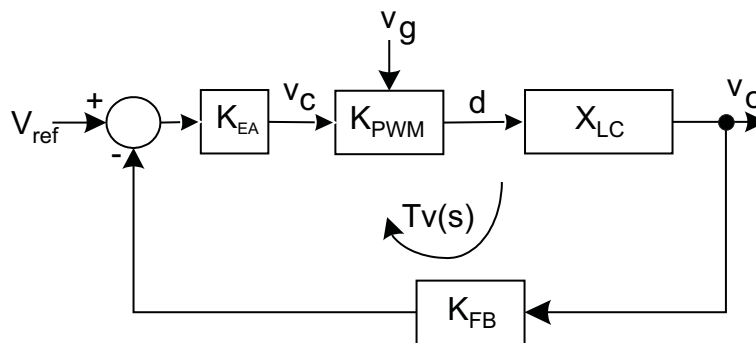

**Figure 34. Control Loop**

Figure 35 shows the feedback network used in this application. This is a Type II compensation network which gives a combination of good transient response and phase boost for good stability. This type of compensation has a pole at the origin causing a  $-20\text{dB/decade}$  ( $-1$ ) slope followed by a zero that causes a region of flat gain followed by a final pole that returns the gain slope to  $-1$ . The bode plot in Figure 36 shows the effect of these poles and zeros.

The procedure for setting up the compensation network is as follows:

1. Determine the break frequency of the output capacitor.
2. Select a zero frequency well below this break frequency.
3. From the gain bandwidth of the error amplifier select a crossover frequency where the amplifier gain is large relative to expected closed loop gain
4. Select a second zero well above the crossover frequency, that returns the gain slope to a  $-1$  slope.
5. Calculate the required gain for the amplifier at crossover.

Be prepared to iterate this procedure to optimize the pole and zero locations as needed.

The frequency response of this converter is largely determined by two poles that arise from the LC output filter and a higher frequency zero caused by the ESR of the output capacitance. The poles from the output filter cause a  $-40\text{ dB/decade}$  roll off with a phase shift approaching  $180$  degrees followed by the output capacitor zero that reduced the roll off to  $-20\text{ dB}$  and gives a phase boost back toward  $90$  degrees. In other nomenclature, this is a  $-2$  slope followed by a  $-1$  slope. The two zeros in the compensation network act to cancel the double pole from the output filter. The compensation network's two poles produce a region where the error amplifier is flat and can be set to a gain such that the overall gain of the system is zero dB. This region is set so that it brackets the system crossover frequency.

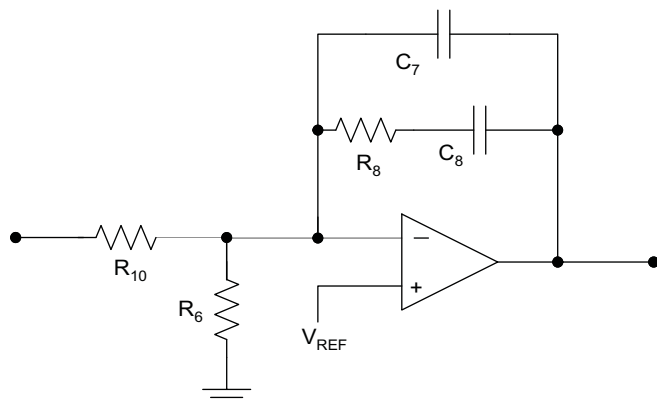

**Figure 35. Error Amplifier Feedback Elements**

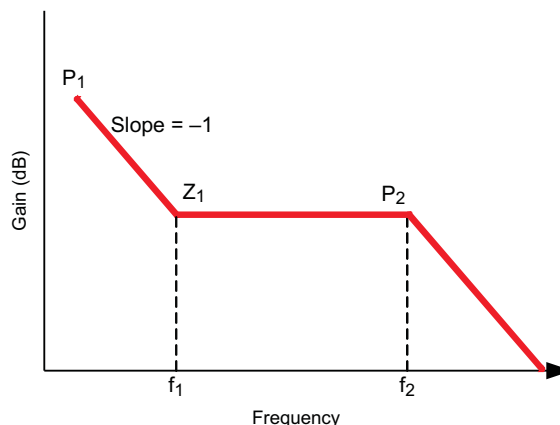

**Figure 36. Error Amplifier Bode Plot**

In order to properly compensate this system, it is necessary to know the frequencies of its poles and zeros.

#### 8.2.1.2.8.1 Step 1

The break frequency of the output capacitor is given by:

$$f_{\text{ESR}} = \frac{1}{2\pi \times R_{\text{ESR}} \times C_{\text{OUT}}} \quad (21)$$

Where

$C_{\text{OUT}}$  = the output capacitor, 220  $\mu\text{F}$

$R_{\text{ESR}}$  = the ESR of the capacitors

Because of the ESR of the output capacitor, the output LC filter has a single-pole response above the 1.8-kHz break frequency of the output capacitor and its ESR. This simplifies compensation since the system becomes essentially a single pole system.

#### 8.2.1.2.8.2 Step 2

The first zero is placed well below the 1.8-kHz break frequency of the output capacitor and its ESR. The phase boost from this zero is shown in [Figure 38](#).

$$f_{\text{Z1}} = \frac{1}{2\pi \times R_8 \times C_8} \quad (22)$$

Where

$R_8 = 300 \text{ k}\Omega$

$C_8 = 1500 \text{ pF}$

$f_{\text{Z1}} = 354 \text{ Hz}$

#### 8.2.1.2.8.3 Step 3

From its minimum gain bandwidth product of 1.5 MHz, and knowing it has a 20 dB/decade roll off, the open-loop gain of the error amplifier is 33 dB at 35 kHz. This approximate frequency is chosen for a crossover frequency to keep the amplifier gain contribution to the overall system gain small, as well as following the convention of placing the crossover frequency between 1/6 to 1/10 the 300 kHz switching frequency.

#### 8.2.1.2.8.4 Step 4

The second pole is placed well above the 35 kHz crossover frequency.

$$f_{\text{P2}} = \frac{1}{2\pi \times C_7 \times C_8 \times R_8} \times (C_7 + C_8) \quad (23)$$

Where

$R_8 = 300 \text{ k}\Omega$

$C_7 = 10 \text{ pF}$

$C_8 = 1500 \text{ pF}$

$f_{\text{P2}} = 53 \text{ kHz}$

**8.2.1.2.8.5 Step 5**

Calculate the gain elements in the system to determine the gain required by the error amplifier to make the overall gain 0 dB at 35 kHz.

The total gain around the voltage feedback loop is:

$$T_{V(S)} = K_{FB} \times K_{EA}(S) \times K_{PWM} \times X_{LC}(S) \tag{24}$$

Where

- $K_{FB}$  is the output voltage setting divider
- $K_{EA}$  is the error amplifier feedback
- $K_{PWM}$  is the modulator gain
- $X_{LC}$  is the filter transfer function

With reference to the graphic below, the output filter's transfer characteristic  $X_{LC}(S)$  can be estimated by the following:

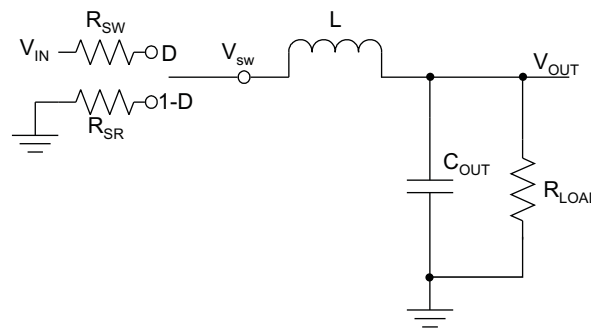

**Figure 37. Output Filter Analysis**

$$X_{LC}(S) = \frac{Z_{OUT}(S)}{Z_{OUT}(S) + Z_L(S) + R_{SW} \times D + R_{SR} \times (1-D)} \tag{25}$$

Where

- $Z_{OUT}$  is the parallel combination of output capacitor(s) and the load
- $R_{SW}$  is the  $R_{DS(on)}$  of the switching FET plus the current-sense resistor
- $R_{SR}$  is the resistance of the synchronous rectifier
- $D$  is the duty cycle estimated as  $3.3 / 12 = 0.27$

To evaluate  $X_{LC}(S)$  at 35 kHz use the following:

- $Z_{OUT}(s)$  at 35 kHz, which is dominated by the output capacitor's ESR; estimated to be 400 mΩ
- $Z_L(s)$  at 35 kHz is 7.25 Ω
- $R_{SW} = 0.95$  mΩ, including the  $R_{LIM}$  resistance
- $R_{SR} = 100$  mΩ

Using these numbers,  $X_{LC}(S) = 0.04$  or  $-27.9$  dB.

The feedback network has a gain to the error amplifier given by:

$$K_{fb} = \frac{R_{10}}{R_6} \tag{26}$$

Where

for 3.3  $V_{OUT}$ ,  $R_6 = 26.7$  kΩ

Using the values in this application,  $K_{fb} = 11.4$  dB.

The modulator has a gain of 10 that is flat to well beyond 35 kHz, so  $K_{PWM} = 20$  dB.

To achieve 0 db overall gain, the amplifier and feedback gain must be set to  $-7.9$  dB ( $20$  dB  $- 27.9$ dB).

The amplifier gain, including the feedback gain,  $K_{fb}$ , can be approximated by this expression:

$$\frac{V_{OUT}}{V_{IN}} (S) = \frac{A_{VOL}}{1 + \frac{R_{10}}{R_8} + \frac{R_{10}}{Z_{FS}}} \times (1 + A_{VOL}) \tag{27}$$

Where

$Z_{fs}$  is the parallel combination of  $C_7$  in parallel with the sum of  $R_8$  and the impedance of  $C_8$ .

$A_{VOL}$  is the open-loop gain of the error amplifier at 35 kHz, which is 44.6 dB or 33 dB.

Figure 38 shows the result of the compensation. The crossover frequency is 35 kHz and the phase margin is 45°. The response of the system is dominated by the ESR of the output capacitor and is exploited to produce an essentially single-pole system with simple compensation.

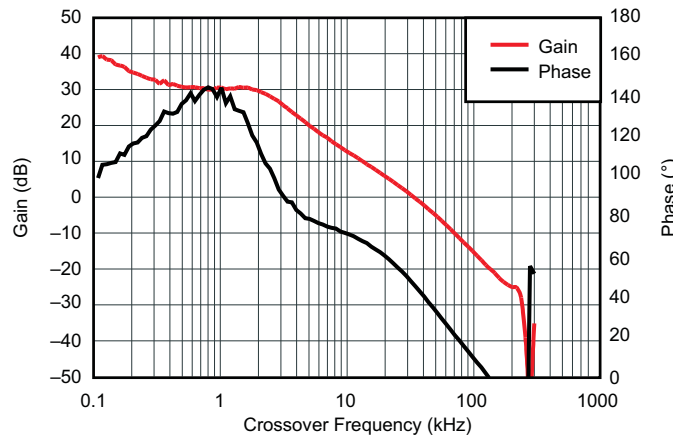

Figure 38. Overall System Gain and Phase Response

Figure 38 also shows the phase boost that gives the system a crossover phase margin of 47°.

The bill of materials for this application is shown below. The efficiency and load regulation from boards built from this design are shown in the following two figures. Gerber PCB layout files and additional application information are available from the factory.

**Table 2. Bill of Materials, Buck Regulator, 12 V to 3.3 V and 5.0 V**

REF. DES.	VALUE	DESCRIPTION	SIZE	MFR.	PART NUMBER
C1	100 $\mu$ F	Capacitor, Aluminum, SM, 25V, 0.3 $\Omega$	8 x 10 mm	Sanyo	20SVP100M
C12	220 $\mu$ F	Capacitor, Aluminum, SM, 6.3V, 0.4 $\Omega$	8 x 6.2 mm	Panasonic	EEVFC0J221P
C13	100 pF	Capacitor, Ceramic, 50V, [COG], [20%]	603	muRata	Std.
C3	0.1 pF	Capacitor, Ceramic, 50V, [X7R], [20%]	603	muRata	Std.
C2, C11	1 $\mu$ F	Capacitor, Ceramic, 50V, [X7R], [20%]	603	muRata	Std.
C4, C5	470 pF	Capacitor, Ceramic, 50V, [X7R], [20%]	603	muRata	Std.
C6	0.047 $\mu$ F	Capacitor, Ceramic, 50V, [X7R], [20%]	603	muRata	Std.
C7	10 pF	Capacitor, Ceramic, 50V, [COG], [20%]	603	muRata	Std.
C8	1500 pF	Capacitor, Ceramic, 50V, [X7R], [20%]	603	muRata	Std.
D1	12 V	Diode, Zener, 12-V, 350mW	SOT23	Diodes, Inc.	BZX84C12T
D2		Diode, Schottky, 30A, 30V	SMC	On Semi	MBRS330T3
D3	12 V	Diode Zener 12V 5mA	VMD2	Rohm	VDZT2R12B
J1,J3		Terminal Block 4-Pin 15A 5.1 mm	0.8 x 0.35	OST	ED2227
J2		Header, 2-pin, 100 mil spacing, (36-pin strip)	0.100 x 2	Sullins	PTC36SAAN
L1	33 $\mu$ H	Inductor, SMT, 3.2A, .039 $\Omega$	12.5 x 12.5 mm	TDK	SLF12575T330M3R2PF
PCB		2 Layer PCB 2 Ounce Cu	1.4 x 2.12 x 0.062		HPA164
Q1		Trans, N-Chan Enhancement Switching, 50mA	SOT-143B	Phillips	BSS83
Q2		MOSFET, P-ch, 30V, 3.6A, 75m $\Omega$	SuperSOT-6	Fairchild	FDC654P
U1		IC, Low Cost Non-Sync Buck Controller	SO-8	TI	TPS40200D
R1	10 $\Omega$	Resistor, Chip, 1/16W, 1%	603	Std.	Std.
R10	100 k $\Omega$	Resistor, Chip, , 1/16W, 1%	603	Std.	Std.
R11	10 k $\Omega$	Resistor, Chip, 1/16W, 1%	603	Std.	Std.
R12	1 M $\Omega$	Resistor, Chip, 1/16W, 1%	603	Std.	Std.
R13	49.9 $\Omega$	Resistor, Chip, 1/16W, 1%	603	Std.	Std.
R2	0.02 $\Omega$	Resistor, Chip, ½ W, 5%	2010	Std.	Std.
R3	68.1 k $\Omega$	Resistor, Chip, 1/16W, 1%	603	Std.	Std.
R4	2.0 k $\Omega$	Resistor, Chip, 1/16W, 1%	603	Std.	Std.
R5	0 $\Omega$	Resistor, Chip, 1/16W, 1%	603	Std.	Std.
R6	26.7 k $\Omega$	Resistor, Chip, 1/16W, 1%	603	Std.	Std.
R7	1.0 k $\Omega$	Resistor, Chip, 1/16W, 1%	603	Std.	Std.
R8	300 k $\Omega$	Resistor, Chip, 1/16W, 1%	603	Std.	Std.

### 8.2.1.2.9 Printed Circuit Board Plots

The following figures [Figure 39](#) through [Figure 41](#) show the design of the TPS40200EVM-001 printed circuit board. The design uses 2-layer, 2-oz copper and is 1.4" x 2.3" in size. All components are mounted on the top side to allow the user to easily view, probe, and evaluate the TPS40200 control IC in a practical application. Moving components to both sides of the printed circuit board (PCB) or using additional internal layers can offer additional size reduction for space constrained applications.

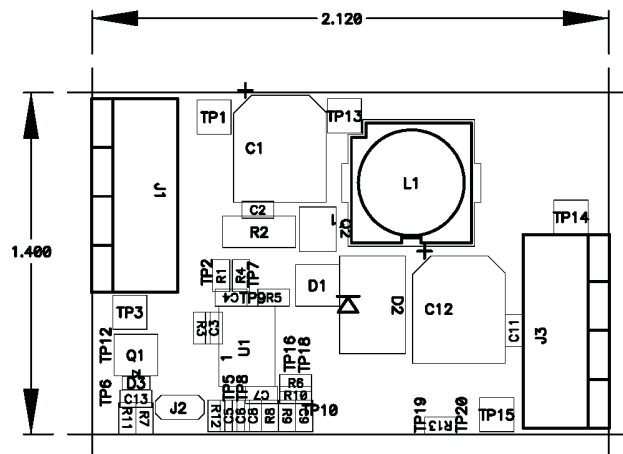

**Figure 39. TPS40200EVM-001 Component Placement (Viewed from Top)**

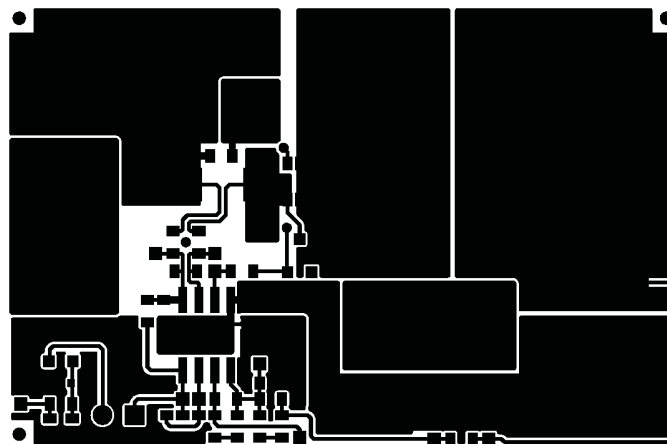

**Figure 40. TPS40200EVM-001 Top Copper (Viewed from Top)**



**Figure 41. TPS40200EVM-001 Bottom Copper (X-Ray View from Top)**



### 8.2.1.3 Application Curves

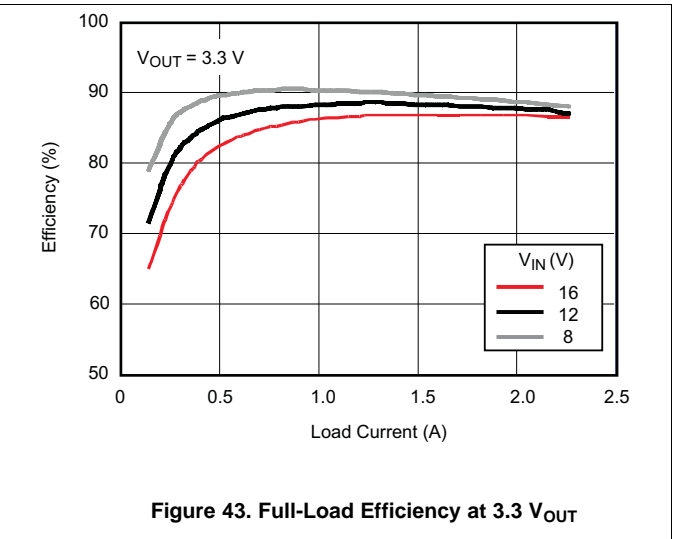
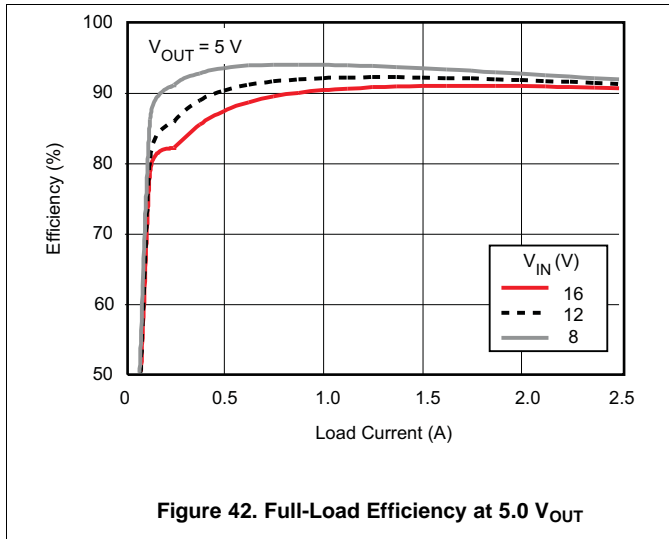

### 8.2.2 18 V - 50 V Input, 16 V at 1-A Output

This is an example of using the TPS40200 in a higher voltage application. The output voltage is 16 V at 1 A with an 18 V to 50 V input. Some of the test results are shown below.

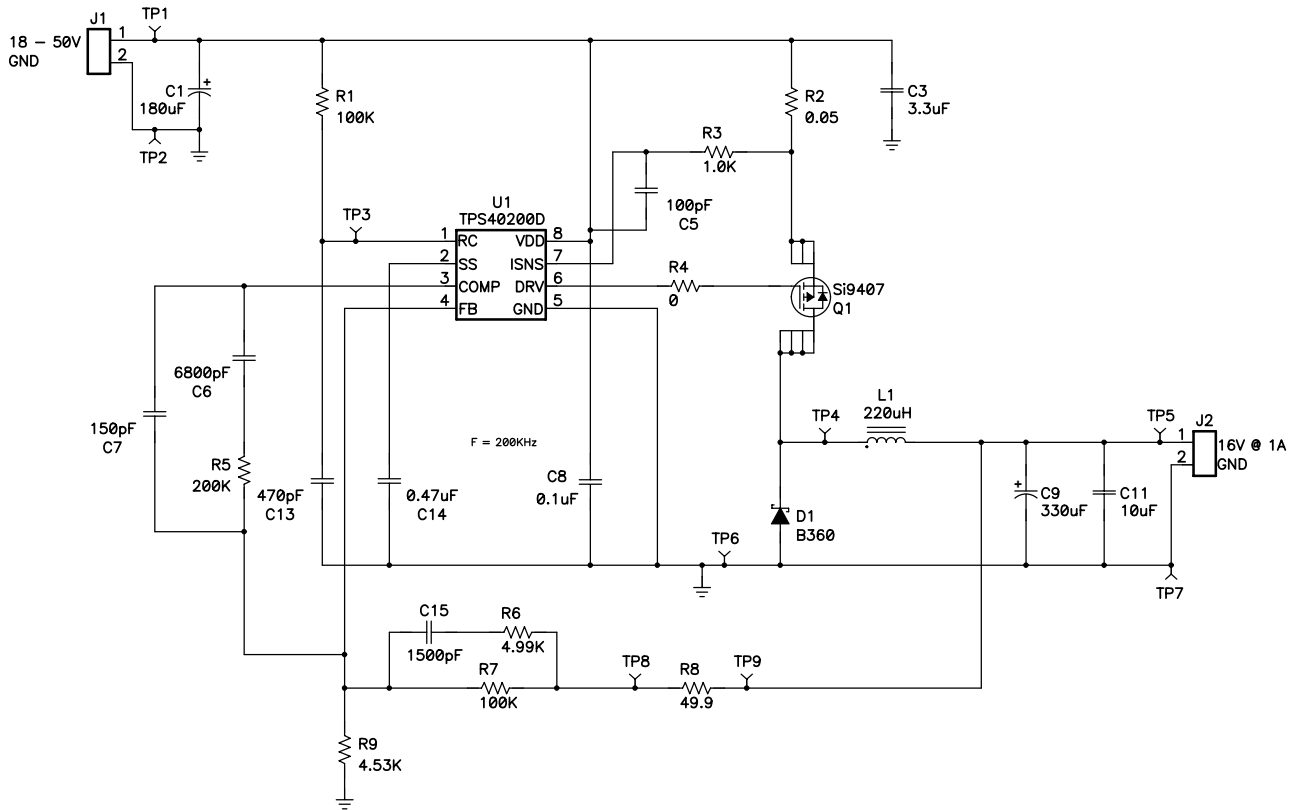

### 8.2.2.1 Design Requirements

**Table 3. Design Parameters**

PARAMETER		MIN	NOM	MAX	UNIT
$V_{IN}$	Input Voltage	18		50	V
$V_{OUT}$	Output Voltage		16		
$I_{OUT}$	Output Current			1	A
$I_{SCP}$	Short circuit current trip point		2		
$F_S$	Switching Frequency		200		kHz

### 8.2.2.2 Detailed Design Procedures

Using the design parameters stated in [Table 3](#), follow the detailed design procedures listed under [Detailed Design Procedure](#).

### 8.2.2.3 Application Curves

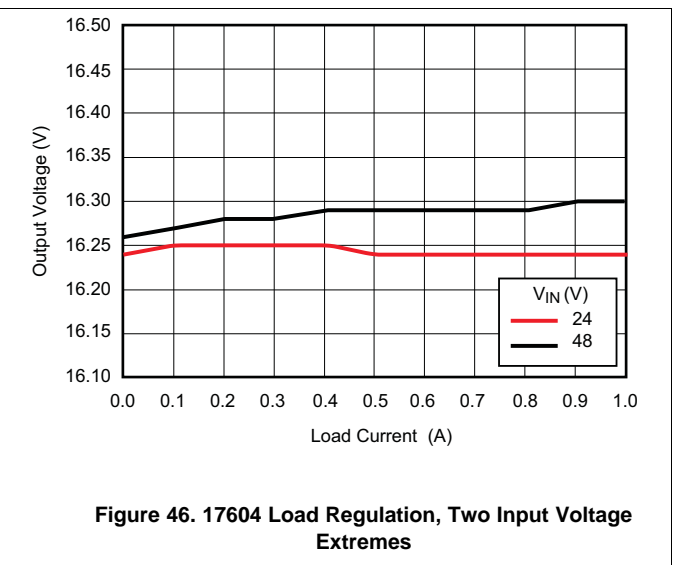
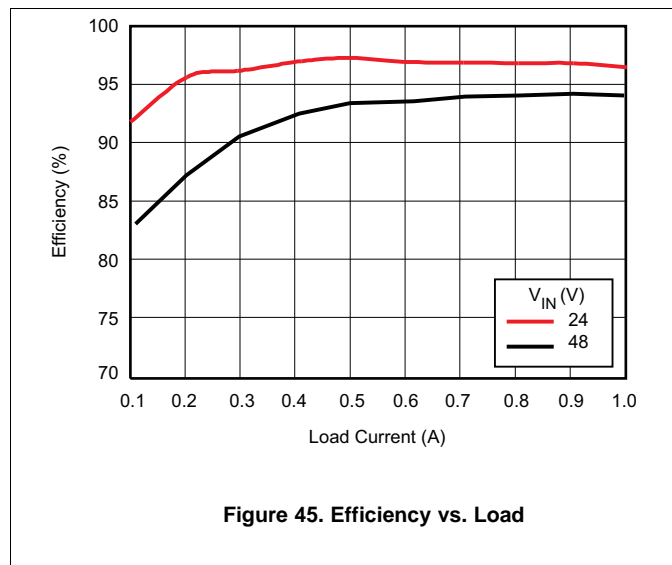

### 8.2.3 Wide Input Voltage Led Constant Current Driver

This application uses the TPS40200 as a buck controller that drives a string of LED diodes. The feedback point for this circuit is a sense resistor in series with this string. The low 0.7 V reference minimizes power wasted in this resistor, and maintains the LED current at a value given by  $0.7/R_{SENSE}$ . As the input voltage is varied, the duty cycle changes to maintain the LED current at a constant value so that the light intensity does not change with large input voltage variations.

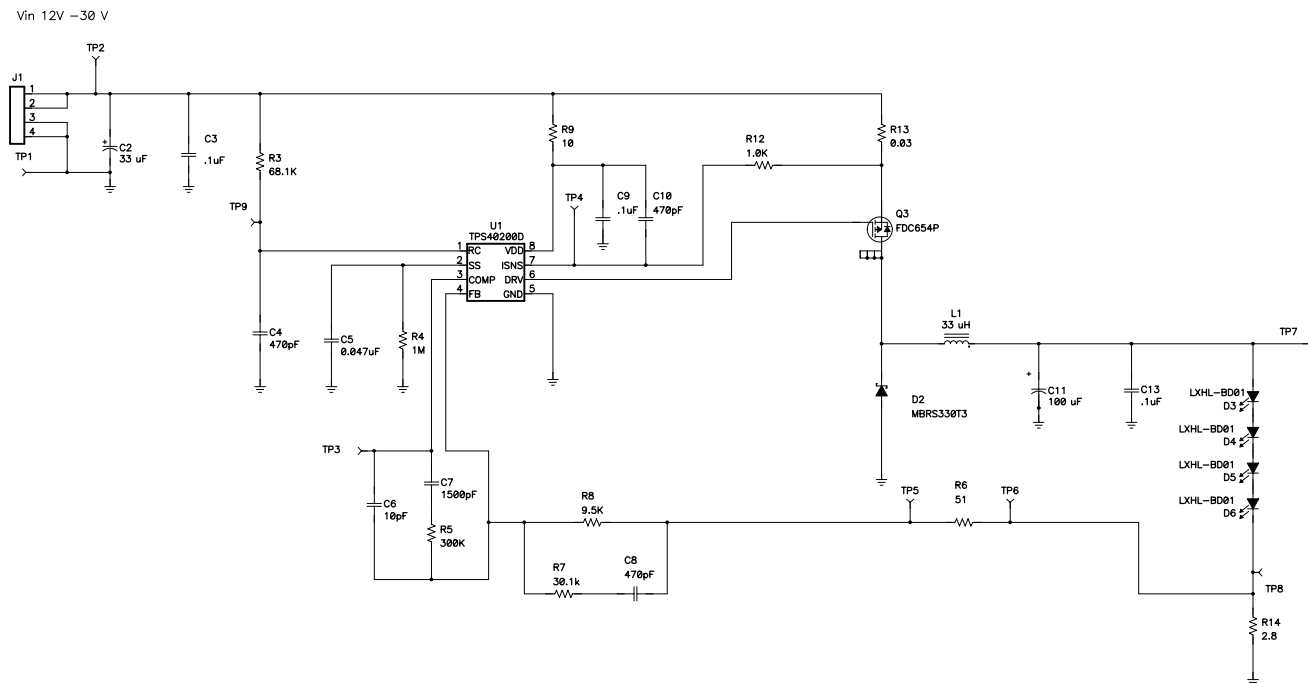

Figure 47. Wide-Input Voltage Range LED Driver

#### 8.2.3.1 Design Requirements

Table 4. Design Parameters

PARAMETER		MIN	NOM	MAX	UNIT
$V_{IN}$	Input Voltage	12		30	V
$I_{LED}$	Output Voltage		0.25		A
$I_{SCP}$	Short circuit current trip point		3.3		A
$F_S$	Switching Frequency		300		kHz

### 8.2.3.2 Detailed Design Procedures

Using the design parameters stated in [Table 4](#), follow the detailed design procedures listed under [Detailed Design Procedure](#).

### 8.2.3.3 Application Curve

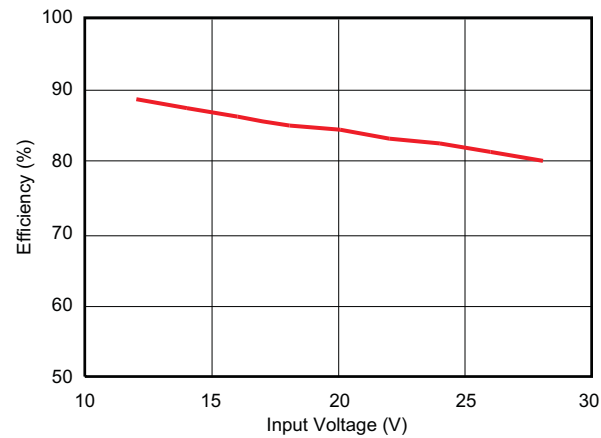

**Figure 48. Efficiency vs Input Voltage**

## 9 Power Supply Recommendations

The TPS40200 is designed to operate from an input voltage supply range between 4.5 V and 52 V. This input supply should be well regulated. If the input supply is located more than a few inches from the buck power stage controlled by the TPS40200, additional bulk capacitance may be required in addition to the ceramic-bypass capacitors. An electrolytic capacitor with a value of 100  $\mu$ F is a typical choice.

## 10 Layout

### 10.1 Layout Guidelines

- Keep the AC current loops as short as possible. For the maximum effectiveness from C3, place it near the VDD pin of the controller and design the input AC loop consisting of C1-R<sub>SENSE</sub>-Q1-D1 to be as short as possible. Excessive high frequency noise on VDD during switching degrades overall regulation as the load increases.
- Keep the output loop A (D1-L1-C2) as small as possible. A larger loop can degrade the application output noise performance.
- Traces carrying large AC currents should NOT be connected through a ground plane. Instead, use PCB traces on the top layer to conduct the AC current and use the ground plane as a noise shield. Split the ground plane as necessary to keep noise away from the TPS40200 and noise sensitive areas such as feedback resistors R6, and R10.
- Keep the SW node as physically small as possible to minimize parasitic capacitance and to minimize radiated emissions.
- For good output voltage regulation, Kelvin connections should be brought from the load to R6 and R10.
- The trace from the R6-R10 junction to the TPS40200 should be short and kept away from any noise source (such as the SW node).
- The gate drive trace should be as close as possible to the power FET gate.

### 10.2 Layout Example

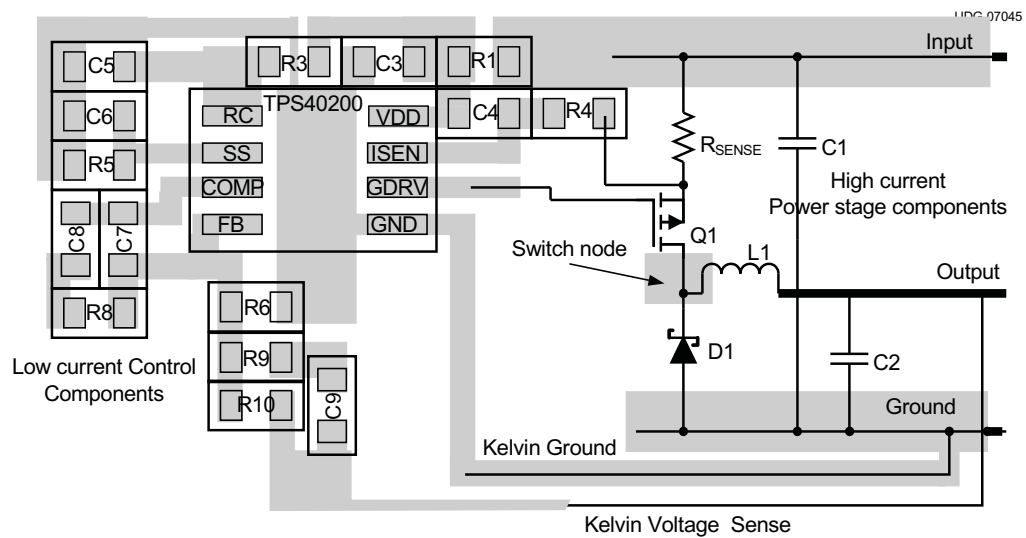
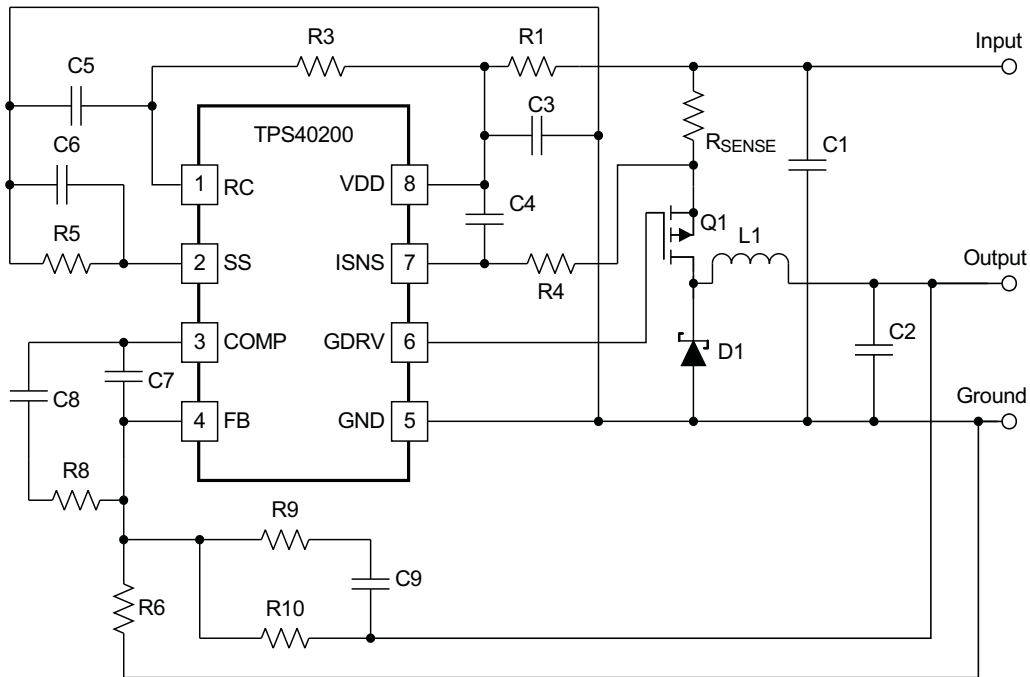

Figure 49. PC Board Layout Recommendations

## 11 Device and Documentation Support

### 11.1 Device Support

#### 11.1.1 Related Products

DEVICE NUMBER	DESCRIPTION
<a href="#">TPS4007</a>	Low Input Synchronous Buck Controller
<a href="#">TPS4009</a>	
<a href="#">TL5001</a>	Wide Input Range Controller
<a href="#">TPS40057</a>	Wide input (8V to 40V) Synchronous Buck Controller
<a href="#">TPS40190</a>	Low Pin Count Synchronous Buck Controller
<a href="#">TPS40192</a>	– 4.5 V to 18 V Low Pin Count Synchronous Buck Controller
<a href="#">TPS40193</a>	

#### 11.1.2 Third-Party Products Disclaimer

TI'S PUBLICATION OF INFORMATION REGARDING THIRD-PARTY PRODUCTS OR SERVICES DOES NOT CONSTITUTE AN ENDORSEMENT REGARDING THE SUITABILITY OF SUCH PRODUCTS OR SERVICES OR A WARRANTY, REPRESENTATION OR ENDORSEMENT OF SUCH PRODUCTS OR SERVICES, EITHER ALONE OR IN COMBINATION WITH ANY TI PRODUCT OR SERVICE.

### 11.2 Documentation Support

#### 11.2.1 Related Documentation

- *Under the Hood of Low Voltage DC/DC Converters* – SEM1500 Topic 5 – 2002 Seminar Series
- *Understanding Buck Power Stages in Switchmode Power Supplies* – [SLVA057](#)
- *Design and Application Guide for High Speed MOSFET Gate Drive Circuits*- SEM 1400 – 2001 Seminar Series
- *Designing Stable Control Loops* - SEM 1400 – 2001 Seminar Series
- <http://power.ti.com>

### 11.3 Trademarks

All trademarks are the property of their respective owners.

### 11.4 Electrostatic Discharge Caution



These devices have limited built-in ESD protection. The leads should be shorted together or the device placed in conductive foam during storage or handling to prevent electrostatic damage to the MOS gates.

### 11.5 Glossary

[SLYZ022](#) — *TI Glossary*.

This glossary lists and explains terms, acronyms, and definitions.

## 12 Mechanical, Packaging, and Orderable Information

The following pages include mechanical, packaging, and orderable information. This information is the most current data available for the designated devices. This data is subject to change without notice and revision of this document. For browser-based versions of this data sheet, refer to the left-hand navigation.

**PACKAGING INFORMATION**

Orderable Device	Status (1)	Package Type	Package Drawing	Pins	Package Qty	Eco Plan (2)	Lead finish/ Ball material (6)	MSL Peak Temp (3)	Op Temp (°C)	Device Marking (4/5)	Samples
TPS40200D	ACTIVE	SOIC	D	8	75	RoHS & Green	NIPDAU	Level-1-260C-UNLIM	-40 to 85	40200	<a href="#">Samples</a>
TPS40200DG4	ACTIVE	SOIC	D	8	75	RoHS & Green	NIPDAU	Level-1-260C-UNLIM	-40 to 85	40200	<a href="#">Samples</a>
TPS40200DR	ACTIVE	SOIC	D	8	2500	RoHS & Green	NIPDAU	Level-1-260C-UNLIM	-40 to 85	40200	<a href="#">Samples</a>
TPS40200DRBR	ACTIVE	SON	DRB	8	3000	RoHS & Green	NIPDAU	Level-2-260C-1 YEAR	-40 to 85	4200	<a href="#">Samples</a>
TPS40200DRBT	ACTIVE	SON	DRB	8	250	RoHS & Green	NIPDAU	Level-2-260C-1 YEAR	-40 to 85	4200	<a href="#">Samples</a>
TPS40200DRG4	ACTIVE	SOIC	D	8	2500	RoHS & Green	NIPDAU	Level-1-260C-UNLIM	-40 to 85	40200	<a href="#">Samples</a>
TPS40200GDR	ACTIVE	SOIC	D	8	2500	RoHS & Green	NIPDAU	Level-1-260C-UNLIM	-40 to 85	40200	<a href="#">Samples</a>

(1) The marketing status values are defined as follows:

**ACTIVE:** Product device recommended for new designs.

**LIFEBUY:** TI has announced that the device will be discontinued, and a lifetime-buy period is in effect.

**NRND:** Not recommended for new designs. Device is in production to support existing customers, but TI does not recommend using this part in a new design.

**PREVIEW:** Device has been announced but is not in production. Samples may or may not be available.

**OBSOLETE:** TI has discontinued the production of the device.

(2) **RoHS:** TI defines "RoHS" to mean semiconductor products that are compliant with the current EU RoHS requirements for all 10 RoHS substances, including the requirement that RoHS substance do not exceed 0.1% by weight in homogeneous materials. Where designed to be soldered at high temperatures, "RoHS" products are suitable for use in specified lead-free processes. TI may reference these types of products as "Pb-Free".

**RoHS Exempt:** TI defines "RoHS Exempt" to mean products that contain lead but are compliant with EU RoHS pursuant to a specific EU RoHS exemption.

**Green:** TI defines "Green" to mean the content of Chlorine (Cl) and Bromine (Br) based flame retardants meet JS709B low halogen requirements of <=1000ppm threshold. Antimony trioxide based flame retardants must also meet the <=1000ppm threshold requirement.

(3) MSL, Peak Temp. - The Moisture Sensitivity Level rating according to the JEDEC industry standard classifications, and peak solder temperature.

(4) There may be additional marking, which relates to the logo, the lot trace code information, or the environmental category on the device.

(5) Multiple Device Markings will be inside parentheses. Only one Device Marking contained in parentheses and separated by a "~" will appear on a device. If a line is indented then it is a continuation of the previous line and the two combined represent the entire Device Marking for that device.



<sup>(6)</sup> Lead finish/Ball material - Orderable Devices may have multiple material finish options. Finish options are separated by a vertical ruled line. Lead finish/Ball material values may wrap to two lines if the finish value exceeds the maximum column width.

**Important Information and Disclaimer:**The information provided on this page represents TI's knowledge and belief as of the date that it is provided. TI bases its knowledge and belief on information provided by third parties, and makes no representation or warranty as to the accuracy of such information. Efforts are underway to better integrate information from third parties. TI has taken and continues to take reasonable steps to provide representative and accurate information but may not have conducted destructive testing or chemical analysis on incoming materials and chemicals. TI and TI suppliers consider certain information to be proprietary, and thus CAS numbers and other limited information may not be available for release.

In no event shall TI's liability arising out of such information exceed the total purchase price of the TI part(s) at issue in this document sold by TI to Customer on an annual basis.

**OTHER QUALIFIED VERSIONS OF TPS40200 :**

- Automotive: [TPS40200-Q1](#)
- Enhanced Product: [TPS40200-EP](#)

NOTE: Qualified Version Definitions:

- Automotive - Q100 devices qualified for high-reliability automotive applications targeting zero defects
- Enhanced Product - Supports Defense, Aerospace and Medical Applications

**TAPE AND REEL INFORMATION**

**QUADRANT ASSIGNMENTS FOR PIN 1 ORIENTATION IN TAPE**

\*All dimensions are nominal

Device	Package Type	Package Drawing	Pins	SPQ	Reel Diameter (mm)	Reel Width W1 (mm)	A0 (mm)	B0 (mm)	K0 (mm)	P1 (mm)	W (mm)	Pin1 Quadrant
TPS40200DR	SOIC	D	8	2500	330.0	12.4	6.4	5.2	2.1	8.0	12.0	Q1
TPS40200DRBR	SON	DRB	8	3000	330.0	12.4	3.3	3.3	1.1	8.0	12.0	Q2
TPS40200DRBT	SON	DRB	8	250	180.0	12.4	3.3	3.3	1.1	8.0	12.0	Q2
TPS40200GDR	SOIC	D	8	2500	330.0	12.4	6.4	5.2	2.1	8.0	12.0	Q1

**TAPE AND REEL BOX DIMENSIONS**

\*All dimensions are nominal

Device	Package Type	Package Drawing	Pins	SPQ	Length (mm)	Width (mm)	Height (mm)
TPS40200DR	SOIC	D	8	2500	340.5	338.1	20.6
TPS40200DRBR	SON	DRB	8	3000	853.0	449.0	35.0
TPS40200DRBT	SON	DRB	8	250	210.0	185.0	35.0
TPS40200GDR	SOIC	D	8	2500	340.5	338.1	20.6

**DRB 8**

**GENERIC PACKAGE VIEW**

**VSON - 1 mm max height**

PLASTIC SMALL OUTLINE - NO LEAD

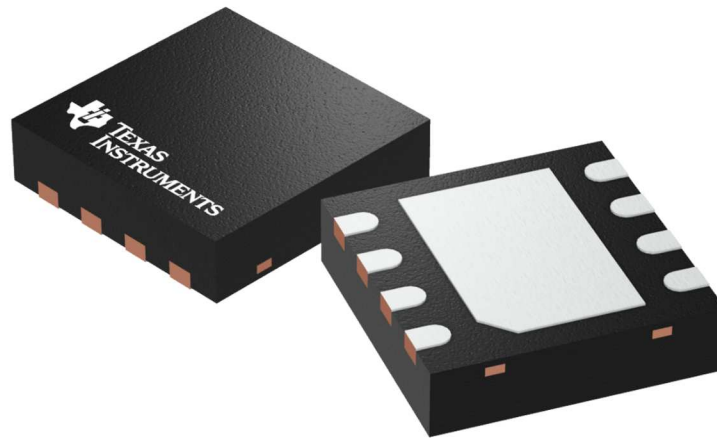

Images above are just a representation of the package family, actual package may vary.  
Refer to the product data sheet for package details.

4203482/L

DRB0008B

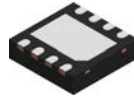

# PACKAGE OUTLINE

VSON - 1 mm max height

PLASTIC SMALL OUTLINE - NO LEAD

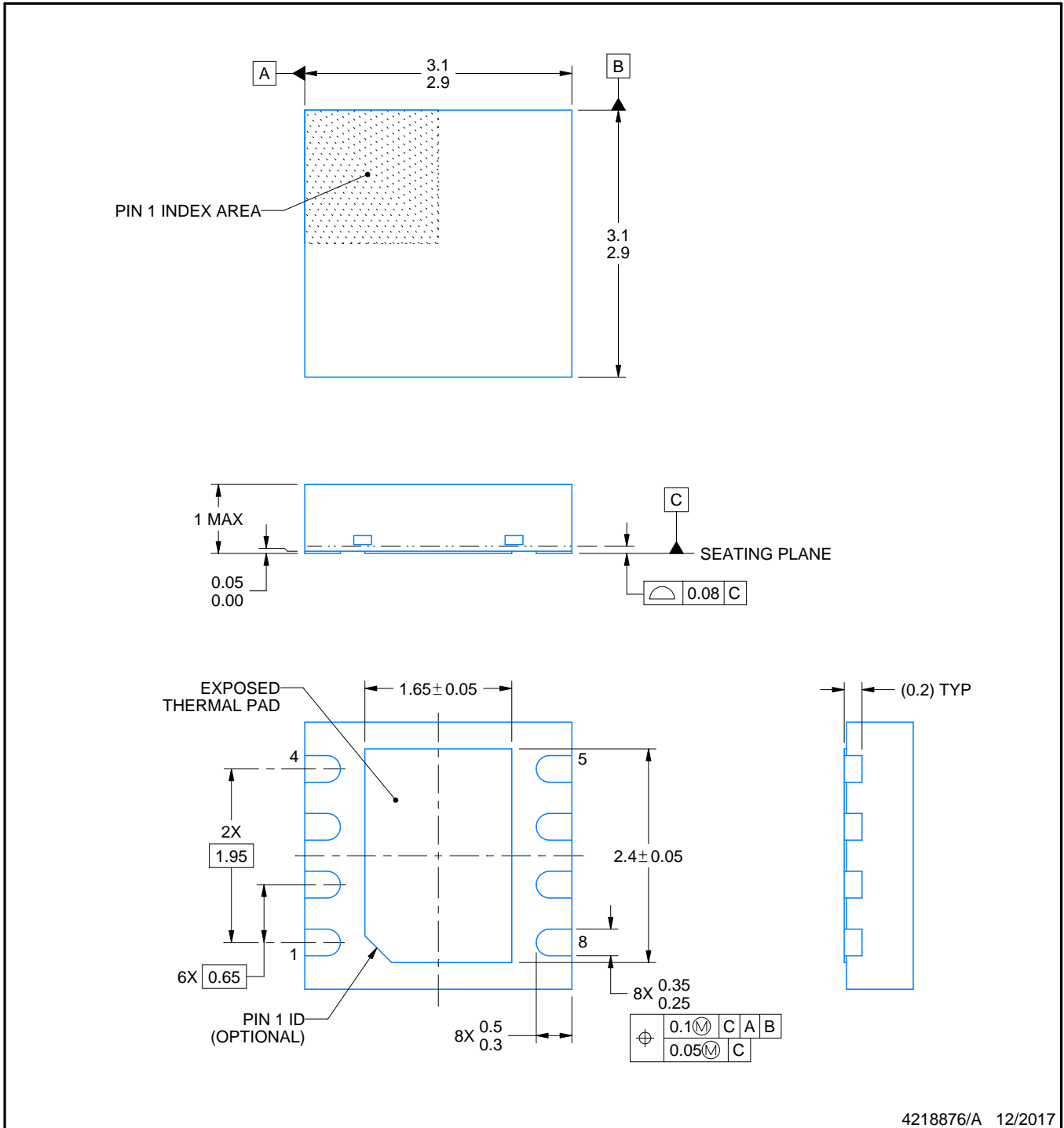

4218876/A 12/2017

**NOTES:**

1. All linear dimensions are in millimeters. Any dimensions in parenthesis are for reference only. Dimensioning and tolerancing per ASME Y14.5M.
2. This drawing is subject to change without notice.
3. The package thermal pad must be soldered to the printed circuit board for thermal and mechanical performance.

# EXAMPLE BOARD LAYOUT

DRB0008B

VSON - 1 mm max height

PLASTIC SMALL OUTLINE - NO LEAD

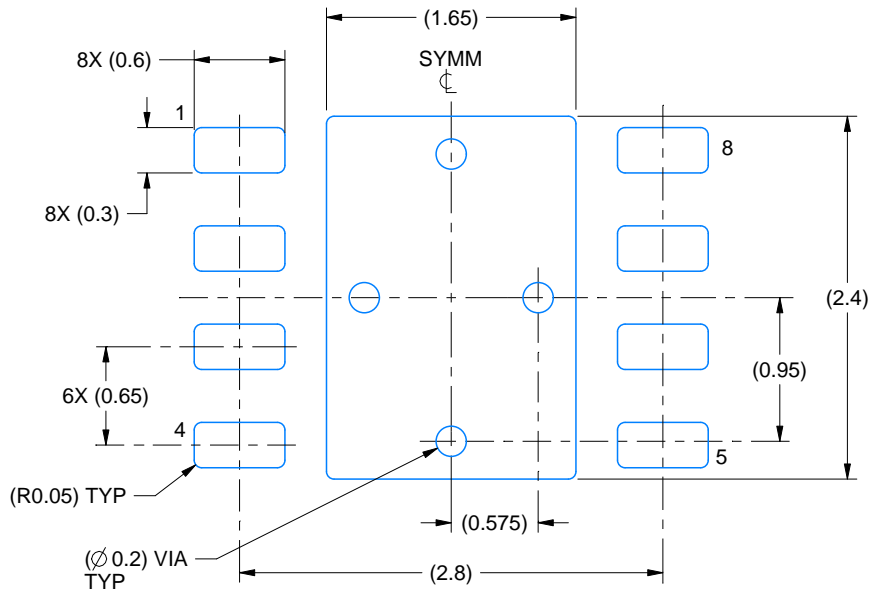

LAND PATTERN EXAMPLE  
SCALE:20X

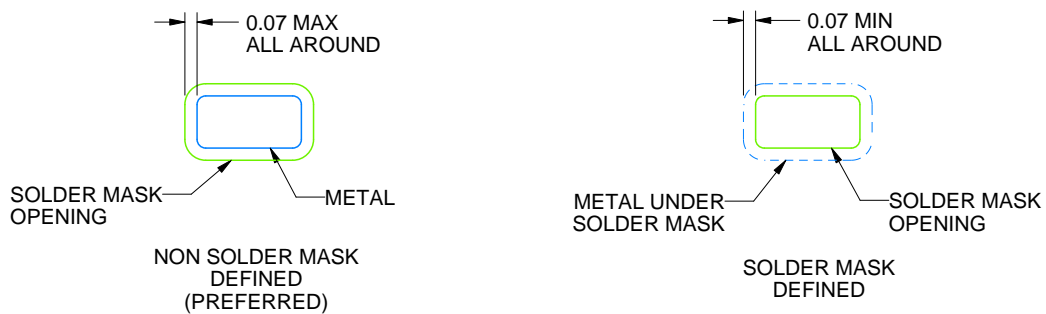

SOLDER MASK DETAILS

4218876/A 12/2017

NOTES: (continued)

4. This package is designed to be soldered to a thermal pad on the board. For more information, see Texas Instruments literature number SLUA271 ([www.ti.com/lit/sluea271](http://www.ti.com/lit/sluea271)).
5. Vias are optional depending on application, refer to device data sheet. If any vias are implemented, refer to their locations shown on this view. It is recommended that vias under paste be filled, plugged or tented.

# EXAMPLE STENCIL DESIGN

DRB0008B

VSON - 1 mm max height

PLASTIC SMALL OUTLINE - NO LEAD

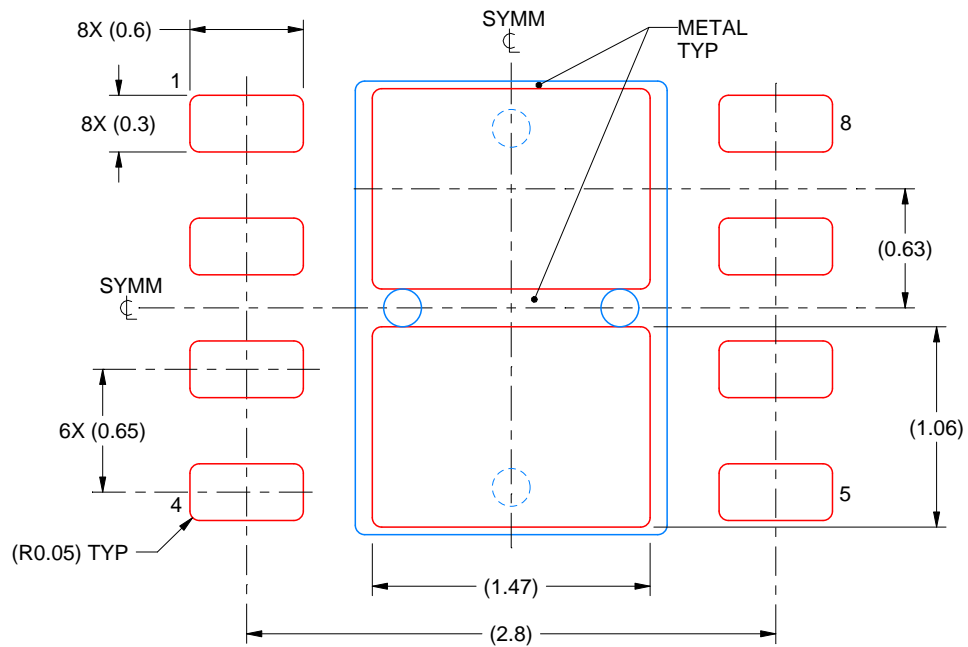

SOLDER PASTE EXAMPLE  
BASED ON 0.125 mm THICK STENCIL

EXPOSED PAD  
81% PRINTED SOLDER COVERAGE BY AREA  
SCALE:25X

4218876/A 12/2017

NOTES: (continued)

6. Laser cutting apertures with trapezoidal walls and rounded corners may offer better paste release. IPC-7525 may have alternate design recommendations.



D0008A

# PACKAGE OUTLINE

SOIC - 1.75 mm max height

SMALL OUTLINE INTEGRATED CIRCUIT



4214825/C 02/2019

NOTES:

1. Linear dimensions are in inches [millimeters]. Dimensions in parenthesis are for reference only. Controlling dimensions are in inches. Dimensioning and tolerancing per ASME Y14.5M.
2. This drawing is subject to change without notice.
3. This dimension does not include mold flash, protrusions, or gate burrs. Mold flash, protrusions, or gate burrs shall not exceed  $.006$  [0.15] per side.
4. This dimension does not include interlead flash.
5. Reference JEDEC registration MS-012, variation AA.



# EXAMPLE BOARD LAYOUT

D0008A

SOIC - 1.75 mm max height

SMALL OUTLINE INTEGRATED CIRCUIT



LAND PATTERN EXAMPLE  
 EXPOSED METAL SHOWN  
 SCALE:8X



SOLDER MASK DETAILS

4214825/C 02/2019

NOTES: (continued)

- 6. Publication IPC-7351 may have alternate designs.
- 7. Solder mask tolerances between and around signal pads can vary based on board fabrication site.

# EXAMPLE STENCIL DESIGN

D0008A

SOIC - 1.75 mm max height

SMALL OUTLINE INTEGRATED CIRCUIT



SOLDER PASTE EXAMPLE  
BASED ON .005 INCH [0.125 MM] THICK STENCIL  
SCALE:8X

4214825/C 02/2019

NOTES: (continued)

8. Laser cutting apertures with trapezoidal walls and rounded corners may offer better paste release. IPC-7525 may have alternate design recommendations.
9. Board assembly site may have different recommendations for stencil design.

## IMPORTANT NOTICE AND DISCLAIMER

TI PROVIDES TECHNICAL AND RELIABILITY DATA (INCLUDING DATASHEETS), DESIGN RESOURCES (INCLUDING REFERENCE DESIGNS), APPLICATION OR OTHER DESIGN ADVICE, WEB TOOLS, SAFETY INFORMATION, AND OTHER RESOURCES "AS IS" AND WITH ALL FAULTS, AND DISCLAIMS ALL WARRANTIES, EXPRESS AND IMPLIED, INCLUDING WITHOUT LIMITATION ANY IMPLIED WARRANTIES OF MERCHANTABILITY, FITNESS FOR A PARTICULAR PURPOSE OR NON-INFRINGEMENT OF THIRD PARTY INTELLECTUAL PROPERTY RIGHTS.

These resources are intended for skilled developers designing with TI products. You are solely responsible for (1) selecting the appropriate TI products for your application, (2) designing, validating and testing your application, and (3) ensuring your application meets applicable standards, and any other safety, security, or other requirements. These resources are subject to change without notice. TI grants you permission to use these resources only for development of an application that uses the TI products described in the resource. Other reproduction and display of these resources is prohibited. No license is granted to any other TI intellectual property right or to any third party intellectual property right. TI disclaims responsibility for, and you will fully indemnify TI and its representatives against, any claims, damages, costs, losses, and liabilities arising out of your use of these resources.

TI's products are provided subject to TI's Terms of Sale ([www.ti.com/legal/termsofsale.html](http://www.ti.com/legal/termsofsale.html)) or other applicable terms available either on [ti.com](http://ti.com) or provided in conjunction with such TI products. TI's provision of these resources does not expand or otherwise alter TI's applicable warranties or warranty disclaimers for TI products.

Mailing Address: Texas Instruments, Post Office Box 655303, Dallas, Texas 75265  
Copyright © 2020, Texas Instruments Incorporated