

TPS1H200A-Q1 40-V 200-mΩ Single-Channel Smart High-Side Switch

1 Features

- Qualified for Automotive Applications
- AEC-Q100 Qualified With the Following Results:
 - Device Temperature Grade 1: –40°C to +125°C Ambient Operating Temperature Range
 - Device HBM ESD Classification Level H2
 - Device CDM ESD Classification Level C4B
- Single-Channel 200-mΩ Smart High-Side Switch
- Wide Operating Voltage: 3.4 V to 40 V
- Ultra-low Standby Current, < 500 nA
- Adjustable Current Limit With External Resistor
 - ±15% When ≥ 500 mA
 - ±10% When ≥ 1.5 A
- Configurable Behavior After Current Limit
 - Holding Mode
 - Latch-Off Mode With Adjustable Delay Time
 - Auto-Retry Mode
- Supports Stand-Alone Operation Without an MCU
- Protection:
 - Short-to-GND and Overload Protection
 - Thermal Shutdown and Thermal Swing
 - Negative Voltage Clamp for Inductive Loads
 - Loss of GND and Loss of Battery Protection
- Diagnostics:
 - Overload and Short-to-GND Detection
 - Open-Load and Short-to-Battery Detection in ON or OFF State

- Thermal Shutdown and Thermal Swing

2 Applications

- Body Lighting
- Infotainment System
- Advanced Driver Assistance Systems (ADAS)
- Single-Channel High-Side Switch for Submodules
- General Resistive, Inductive, and Capacitive Loads

3 Description

The TPS1H200A-Q1 device is a fully protected single-channel high-side power switch with an integrated 200-mΩ NMOS power FET.

An adjustable current limit improves system reliability by limiting the inrush or overload current. The high accuracy of the current limit improves overload protection, simplifying the front-stage power design. Configurable features besides current limit provide design flexibility in functionality, cost, and thermal dissipation.

The device supports full diagnostics with the digital status output. Open-load detection is available in ON and OFF states. The device supports operation with or without an MCU. Stand-alone mode allows isolated systems to use the device.

Device Information⁽¹⁾

| PART NUMBER | PACKAGE | BODY SIZE (NOM) |
|--------------|------------|-------------------|
| TPS1H200A-Q1 | HVSSOP (8) | 3.00 mm × 3.00 mm |

(1) For all available packages, see the orderable addendum at the end of the data sheet.

Typical Block Diagram

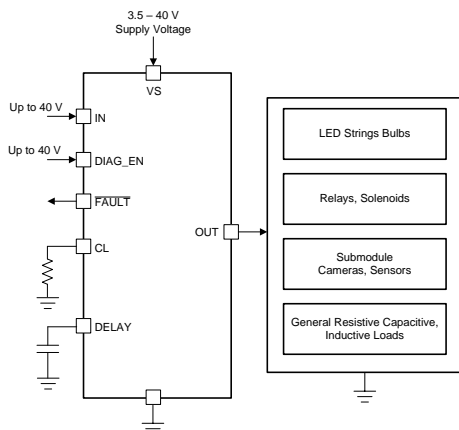

Current Limit Protection in Auto-Retry Mode

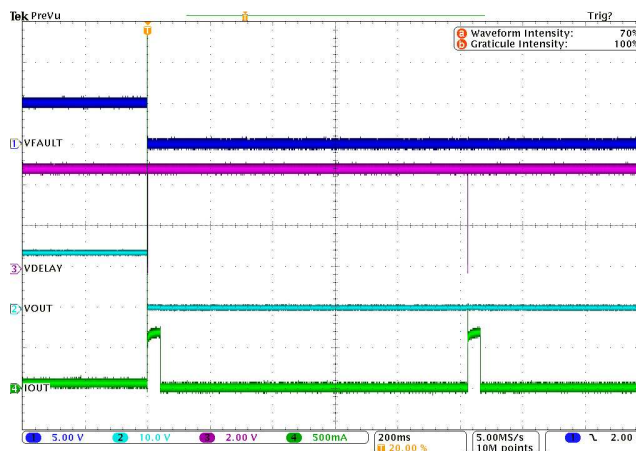

Table of Contents

| | |
|--|--|
| 1 Features 1 2 Applications 1 3 Description 1 4 Revision History 2 5 Pin Configuration and Functions 3 6 Specifications 4 6.1 Absolute Maximum Ratings 4 6.2 ESD Ratings 4 6.3 Recommended Operating Conditions 5 6.4 Thermal Information 5 6.5 Electrical Characteristics 6 6.6 Switching Characteristics 8 6.7 Typical Characteristics 9 7 Detailed Description 11 7.1 Overview 11 7.2 Functional Block Diagram 11 7.3 Feature Description 12 | 7.4 Device Functional Modes 24 8 Application and Implementation 25 8.1 Application Information 25 8.2 Typical Application 25 9 Power Supply Recommendations 27 10 Layout 27 10.1 Layout Guidelines 27 10.2 Layout Example 27 11 Device and Documentation Support 28 11.1 Documentation Support 28 11.2 Receiving Notification of Documentation Updates 28 11.3 Community Resources 28 11.4 Trademarks 28 11.5 Electrostatic Discharge Caution 28 11.6 Glossary 28 12 Mechanical, Packaging, and Orderable Information 29 |
|--|--|

4 Revision History

| Changes from Original (February 2018) to Revision A | Page |
|--|------|
| <ul style="list-style-type: none"> • Changed data sheet status from Advanced Information to Production Data 1 | 1 |

5 Pin Configuration and Functions

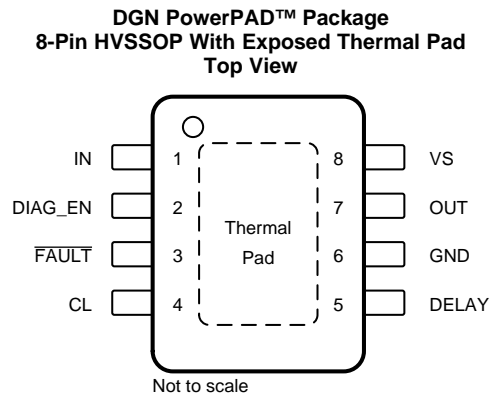

Pin Functions

| PIN | | I/O | DESCRIPTION |
|---------------------------|-----|-----|--|
| NAME | NO. | | |
| CL | 4 | O | Adjustable current limit. Connect to device GND if external current limit is not used. |
| DELAY | 5 | I/O | Function configuration when current limit; internal pullup |
| DIAG_EN | 2 | I | Enable the diagnostic function |
| $\overline{\text{FAULT}}$ | 3 | O | Open-drain diagnostic status output. Leave floating if not used. |
| GND | 6 | — | Ground |
| IN | 1 | I | Input control for output activation; internal pulldown |
| OUT | 7 | O | Output, source of the high-side switch, connected to the load |
| VS | 8 | I | Power supply, drain for the high-side switch |
| Thermal pad | — | — | Thermal pad. Connect to device GND or leave floating. |

6 Specifications

6.1 Absolute Maximum Ratings

 over operating ambient temperature range (unless otherwise noted)⁽¹⁾⁽²⁾

| | | MIN | MAX | UNIT |
|--|---------------|------|-----|------|
| Supply voltage VS pin | t < 400 ms | — | 42 | V |
| Reverse polarity voltage ⁽³⁾ | t < 1 minute | –36 | — | V |
| Current on GND | t < 2 minutes | –100 | 250 | mA |
| Voltage on IN and DIAG_EN pins | | –0.3 | VS | V |
| Current on IN and DIAG_EN pins | | –10 | — | mA |
| Voltage on DELAY pin | | –0.3 | 7 | V |
| Current on DELAY pin | | –60 | — | mA |
| Voltage on $\overline{\text{FAULT}}$ pin | | –0.3 | 7 | V |
| Current on $\overline{\text{FAULT}}$ pin | | –30 | 10 | mA |
| Voltage on CL pin | | –0.3 | 7 | V |
| Current on CL pin | | — | 6 | mA |
| Voltage on OUT pin | | — | 42 | V |
| Inductive load switch-off energy dissipation single pulse ⁽⁴⁾ | | — | 40 | mJ |
| Operating junction temperature, T _J | | –40 | 150 | °C |
| Storage temperature, T _{stg} | | –65 | 150 | °C |

(1) Stresses beyond those listed under *Absolute Maximum Ratings* may cause permanent damage to the device. These are stress ratings only, which do not imply functional operation of the device at these or any other conditions beyond those indicated under *Recommended Operating Conditions*. Exposure to absolute-maximum-rated conditions for extended periods may affect device reliability.

(2) All voltage values are with respect to ground.

(3) Reverse polarity condition: V_{IN} = 0 V, reverse current < I_{R(2)}, GND pin 1-kΩ resistor in parallel with diode.

(4) Test condition: V_{VS} = 13.5 V, L = 8 mH, T_J = 150°C. FR4 2s2p board, 2 × 70-μm Cu, 2 × 35-μm Cu. 600 mm² thermal pad copper area.

6.2 ESD Ratings

| | | | VALUE | UNIT |
|--------------------|-------------------------|---|-------|------|
| V _(ESD) | Electrostatic discharge | Human-body model (HBM), per AEC Q100-002 ⁽¹⁾ | ±2000 | V |
| | | | ±3000 | |
| | | Charged-device model (CDM), per AEC Q100-011 | ±750 | |

(1) AEC-Q100-002 indicates that HBM stressing shall be in accordance with the ANSI/ESDA/JEDEC JS-001 specifications.

6.3 Recommended Operating Conditions

over operating ambient temperature range (unless otherwise noted)

| | | MIN | MAX | UNIT |
|-------------|--|-----|-----|------|
| V_S | Operating voltage | 4 | 40 | V |
| | Voltage on IN and DIAG_EN pins | 0 | 40 | V |
| | Voltage on $\overline{\text{FAULT}}$ pin | 0 | 5 | V |
| $I_{o,nom}$ | Nominal DC load current | 0 | 2.5 | A |
| T_J | Operating junction temperature | -40 | 150 | °C |

6.4 Thermal Information

| THERMAL METRIC ⁽¹⁾ | TPS1H200A-Q1 | | UNIT |
|-------------------------------|--|------|------|
| | DGN (HVSSOP) | | |
| | 8 PINS | | |
| $R_{\theta JA}$ | Junction-to-ambient thermal resistance | 47.4 | °C/W |
| $R_{\theta JC(top)}$ | Junction-to-case (top) thermal resistance | 49.2 | °C/W |
| $R_{\theta JB}$ | Junction-to-board thermal resistance | 18.3 | °C/W |
| ψ_{JT} | Junction-to-top characterization parameter | 0.8 | °C/W |
| ψ_{JB} | Junction-to-board characterization parameter | 18.4 | °C/W |
| $R_{\theta JC(bot)}$ | Junction-to-case (bottom) thermal resistance | 5.6 | °C/W |

(1) For more information about traditional and new thermal metrics, see the [Semiconductor and IC Package Thermal Metrics application report](#).

6.5 Electrical Characteristics

over operating ambient temperature range (unless otherwise noted)

| PARAMETER | | TEST CONDITIONS | MIN | TYP | MAX | UNIT |
|-------------------------------------|--|--|-----|------|-----|---------------|
| OPERATING VOLTAGE | | | | | | |
| $V_{VS(nom)}$ | Nominal operating voltage | | 4 | | 40 | V |
| $V_{VS(uvr)}$ | Undervoltage restart | V_{VS} rising | 3.5 | 3.7 | 4 | V |
| $V_{VS(uvf)}$ | Undervoltage shutdown | V_{VS} falling | 3 | 3.2 | 3.4 | V |
| $V_{(uv,hys)}$ | Undervoltage shutdown, hysteresis | | | 0.5 | | V |
| OPERATING CURRENT | | | | | | |
| $I_{(op)}$ | Nominal operating current | $V_{VS} = 13.5\text{ V}$, $V_{IN} = 5\text{ V}$ $V_{DIAG_EN} = 0\text{ V}$, $I_{OUT} = 0.5\text{ A}$ $I_{CL} = 2\text{ A}$ | | | 5 | mA |
| $I_{(off)}$ | Standby current | $V_{VS} = 13.5\text{ V}$ $V_{IN} = V_{DIAG_EN} = V_{CL} = V_{OUT} = 0\text{ V}$ $T_J = 25^\circ\text{C}$ | | | 0.5 | μA |
| | | $V_{VS} = 13.5\text{ V}$ $V_{IN} = V_{DIAG_EN} = V_{CL} = V_{OUT} = 0\text{ V}$ $T_J = 125^\circ\text{C}$ | | | 3 | |
| $I_{(off,diag)}$ | Standby current with diagnostics enabled | $V_{VS} = 13.5\text{ V}$ $V_{IN} = 0\text{ V}$, $V_{DIAG_EN} = 5\text{ V}$ | | | 3 | mA |
| $t_{(off,deg)}$ | Standby-mode deglitch time ⁽¹⁾ | IN from high to low if deglitch time $\geq t_{(off,deg)}$, then the device enters into standby mode. | | 12.5 | | ms |
| $I_{(lkg,out)}$ | Output leakage current in OFF state | $V_{VS} = 13.5\text{ V}$ $V_{IN} = V_{DIAG_EN} = V_{OUT} = 0\text{ V}$ | | | 3 | μA |
| POWER STAGE | | | | | | |
| $r_{DS(on)}$ | ON state resistance | $V_{VS} \geq 3.5\text{ V}$, $T_J = 25^\circ\text{C}$ | | 200 | | m Ω |
| | | $V_{VS} \geq 3.5\text{ V}$, $T_J = 150^\circ\text{C}$ | | | 400 | |
| $I_{CL(int)}$ | Internal current limit | CL pin connected to GND | 3.5 | 4.8 | 6 | A |
| $I_{CL(TSD)}$ | Current-limit value percentage during thermal shutdown | | | 60% | | |
| $V_{DS(clamp)}$ | Drain-to-source voltage internally clamped | | 45 | | 65 | V |
| OUTPUT DIODE CHARACTERISTICS | | | | | | |
| V_F | Drain-to-source diode voltage | $I_N = 0$, $I_{OUT} = -0.15\text{ A}$ | 0.3 | 0.7 | 1 | V |
| $I_{R(1)}$ | Continuous reverse current from source to drain during a short-to-battery condition ⁽¹⁾ | $t < 60\text{ s}$, $V_{IN} = 0\text{ V}$, $T_J = 25^\circ\text{C}$. | | | 2 | A |
| $I_{R(2)}$ | Continuous reverse current from source to drain during a reverse-polarity condition ⁽¹⁾ | $t < 60\text{ s}$, $V_{IN} = 0\text{ V}$, $T_J = 25^\circ\text{C}$ GND pin 1-k Ω resistor in parallel with diode. | | | 2 | A |
| LOGIC INPUT (IN, DIAG_EN) | | | | | | |
| V_{IH} | Logic high-level voltage | | 2 | | | V |
| V_{IL} | Logic low-level voltage | | | | 0.8 | V |
| $R_{pd,in}$ | Logic-pin pulldown resistor | IN. $V_{IN} = 5\text{ V}$ | 150 | | 400 | k Ω |
| | | DIAG_EN. $V_{VS} = V_{DIAG_EN} = 5\text{ V}$ | 350 | | 850 | |
| DIAGNOSTICS | | | | | | |
| $I_{(lkg(loss,GND))}$ | Loss of ground output leakage current | | | | 100 | μA |
| $t_{d(ol,on)}$ | Open-load deglitch time in ON state | $V_{IN} = 5\text{ V}$, $V_{DIAG_EN} = 5\text{ V}$ when $I_{OUT} < I_{(ol,on)}$, duration longer than $t_{d(ol,on)}$, open load is detected. | 200 | 300 | 450 | μs |

(1) Value specified by design, not subject to production test.

Electrical Characteristics (continued)

over operating ambient temperature range (unless otherwise noted)

| PARAMETER | | TEST CONDITIONS | MIN | TYP | MAX | UNIT |
|--|---|---|------|------|------|--------------------|
| $I_{(ol,on)}$ | Open-load detection threshold in ON state | $V_{IN} = 5\text{ V}$, $V_{DIAG_EN} = 5\text{ V}$ when $I_{OUT} < I_{(ol,on)}$ duration longer than $t_{d(ol,on)}$ open load is detected. | | 10 | 20 | mA |
| $V_{(ol,off)}$ | Open-load detection threshold in OFF state | $V_{IN} = 0\text{ V}$, $V_{DIAG_EN} = 5\text{ V}$ when $V_{VS} - V_{OUT} < V_{(ol,off)}$ duration longer than $t_{d(ol,off)}$ open load is detected. | 1.4 | | 2.6 | V |
| $t_{d(ol,off)}$ | Open-load deglitch time in OFF state | $V_{IN} = 0\text{ V}$, $V_{DIAG_EN} = 5\text{ V}$ when $V_{VS} - V_{OUT} < V_{(ol,off)}$ duration longer than $t_{d(ol,off)}$ open load is detected. | 200 | 300 | 450 | μs |
| $I_{(ol,off)}$ | OFF state output sink current | $V_{IN} = 0\text{ V}$, $V_{DIAG_EN} = 5\text{ V}$ $V_{VS} = V_{OUT} = 13.5\text{ V}$ | -75 | | | μA |
| $\overline{V_{FAULT}}$ | \overline{FAULT} low output voltage | $\overline{I_{FAULT}} = 2\text{ mA}$ | | | 0.2 | V |
| $\overline{t_{FAULT}}$ | \overline{FAULT} signal holding time ⁽¹⁾ | | | 8.5 | | ms |
| $T_{(SD)}$ | Thermal shutdown threshold ⁽¹⁾ | | | 175 | | $^{\circ}\text{C}$ |
| $T_{(SD,rst)}$ | Thermal shutdown status reset ⁽¹⁾ | | | 155 | | $^{\circ}\text{C}$ |
| $T_{(sw)}$ | Thermal swing shutdown threshold ⁽¹⁾ | | | 60 | | $^{\circ}\text{C}$ |
| $T_{(hys)}$ | Hysteresis for resetting the thermal shutdown and swing ⁽¹⁾ | | | 10 | | $^{\circ}\text{C}$ |
| CURRENT LIMIT AND DELAY CONFIGURATION | | | | | | |
| $K_{(CL)}$ | Current-limit current ratio ⁽¹⁾ | | | 2500 | | |
| $V_{CL(th)}$ | Current-limit internal threshold voltage ⁽¹⁾ | | | 0.8 | | V |
| $dK_{(CL)} / K_{(CL)}$ | External current limit accuracy ($I_{OUT} - I_{CL} \times K_{(CL)} \times 100 / (I_{CL} \times K_{(CL)})$) | $I_{limit} \geq 0.25\text{ A}$, $V_{VS} - V_{OUT} \geq 2.5\text{ V}$ | -20% | | 20% | |
| | | $I_{limit} \geq 0.5\text{ A}$, $V_{VS} - V_{OUT} \geq 2.5\text{ V}$ | -15% | | 15% | |
| | | $I_{limit} \geq 1.5\text{ A}$, $I_{limit} < 5\text{ A}$ $V_{VS} - V_{OUT} \geq 2.5\text{ V}$ | -10% | | 10% | |
| $I_{dl(chg)}$ | Delay pin charging current in latch-off mode ⁽¹⁾ | | | 4.5 | | μA |
| $V_{dl(th)}$ | Pulling up threshold in auto-retry mode | | 2.7 | | | V |
| $V_{dl(ref)}$ | Internal reference voltage in latch-off mode | | | 1.45 | | V |
| t_{dl1} | Internal fixed delay time ⁽¹⁾ | | 300 | 400 | 500 | μs |
| t_{dl2} | Adjustable delay time by external capacitor on DELAY pin ⁽¹⁾ | Connect with 3.3 μF capacitor as the maximum value. | | | 1000 | ms |
| $t_{CL(deg)}$ | Deglitch time when current limit ⁽¹⁾ | IN low to high or IN keeps high but thermal shutdown recovery, $V_{DIAG_EN} = 5\text{ V}$ the deglitch time from IN rising edge to \overline{FAULT} reporting out. | 300 | | 550 | μs |
| | | IN keeps high, $V_{DIAG_EN} = 5\text{ V}$ the deglitch time from CL start-point to \overline{FAULT} reporting out. | 80 | | 200 | |
| $t_{hic(on)}$ | On-time when in auto-retry mode ⁽¹⁾ | | 35 | 40 | 45 | ms |
| $t_{hic(off)}$ | Off-time when in auto-retry mode ⁽¹⁾ | | 0.8 | 1 | 1.2 | s |

6.6 Switching Characteristics

| PARAMETER | TEST CONDITIONS | MIN | TYP | MAX | UNIT | |
|-----------------|--|---|-----|------|------|------------------------|
| $t_{d(on)}$ | Turnon delay time IN rising edge to 10% of V_{OUT} | $V_{VS} = 13.5\text{ V}$, $V_{DIAG_EN} = 5\text{ V}$, $I_{OUT} = 0.1\text{ A}$ | 20 | 50 | 90 | μs |
| $t_{d(off)}$ | Turnoff delay time IN falling edge to 90% of V_{OUT} ⁽¹⁾ | $V_{VS} = 13.5\text{ V}$, $V_{DIAG_EN} = 5\text{ V}$, $I_{OUT} = 0.1\text{ A}$ | 20 | 50 | 90 | μs |
| $dV/dt_{(on)}$ | Slew rate on V_{OUT} from 10% to 90% ⁽¹⁾ | $V_{VS} = 13.5\text{ V}$, $V_{DIAG_EN} = 5\text{ V}$, $I_{OUT} = 0.1\text{ A}$ | 0.1 | 0.3 | 0.6 | $\text{V}/\mu\text{s}$ |
| $dV/dt_{(off)}$ | Slew rate off V_{OUT} from 90% to 10% ⁽¹⁾ | $V_{VS} = 13.5\text{ V}$, $V_{DIAG_EN} = 5\text{ V}$, $I_{OUT} = 0.1\text{ A}$ | 0.1 | 0.35 | 0.6 | $\text{V}/\mu\text{s}$ |

(1) Value specified by design, not subject to production test.

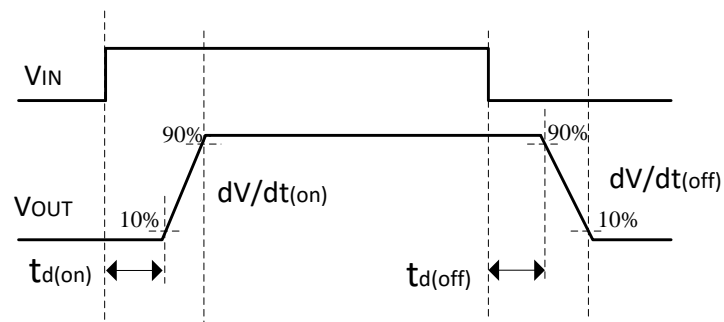

Figure 1. Output Delay Characteristics

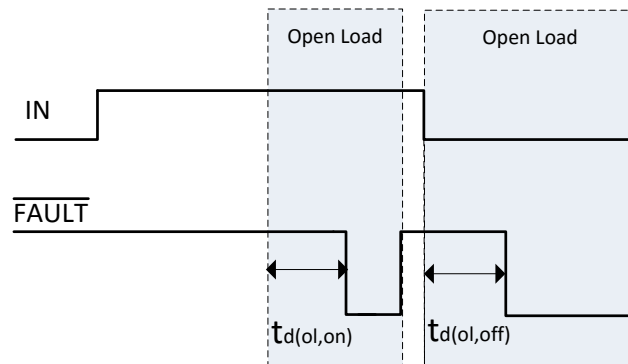

Figure 2. Open-Load Blanking-Time Characteristic

6.7 Typical Characteristics

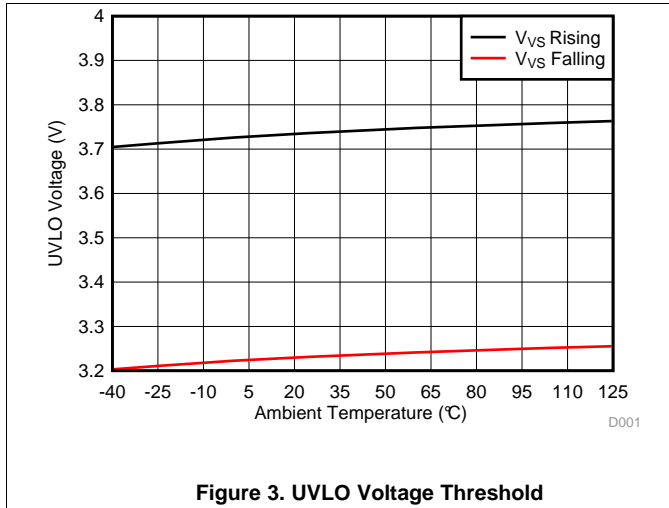

Figure 3. UVLO Voltage Threshold

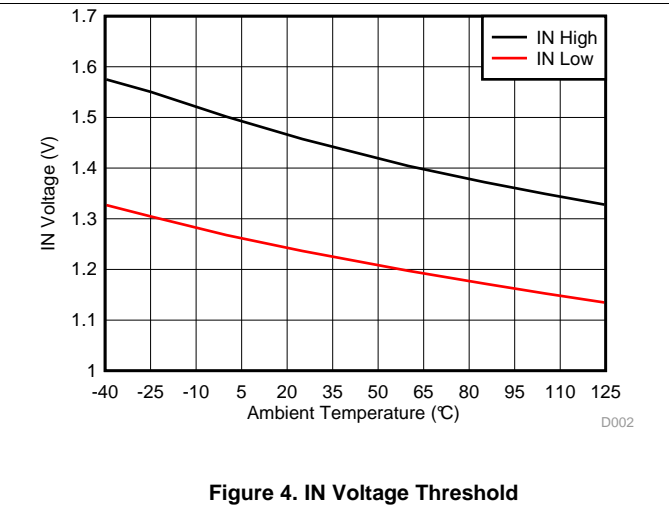

Figure 4. IN Voltage Threshold

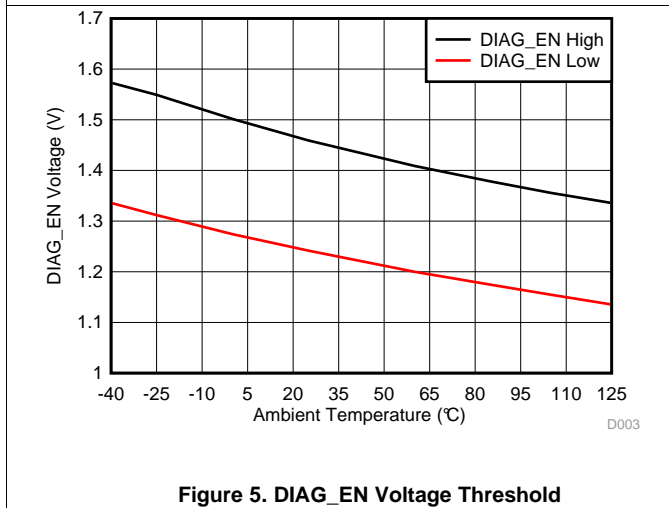

Figure 5. DIAG_EN Voltage Threshold

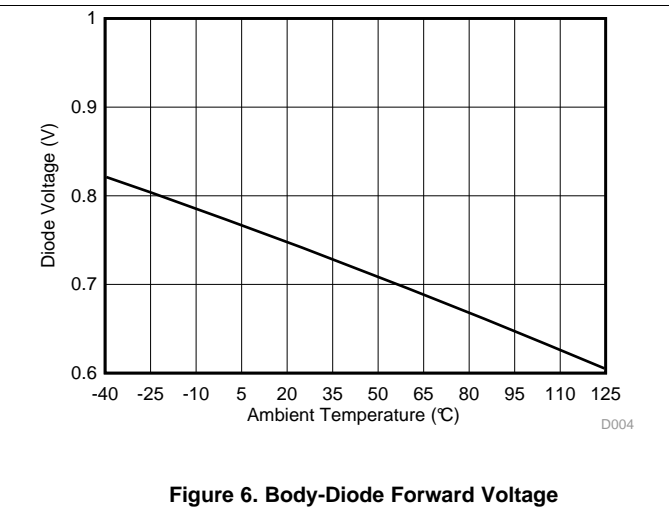

Figure 6. Body-Diode Forward Voltage

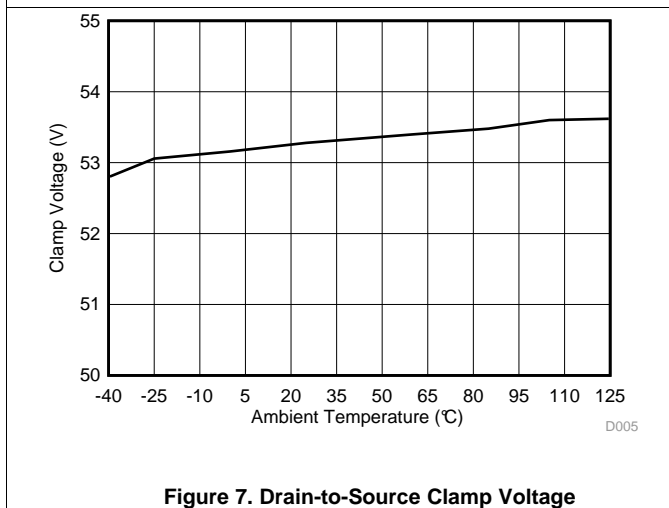

Figure 7. Drain-to-Source Clamp Voltage

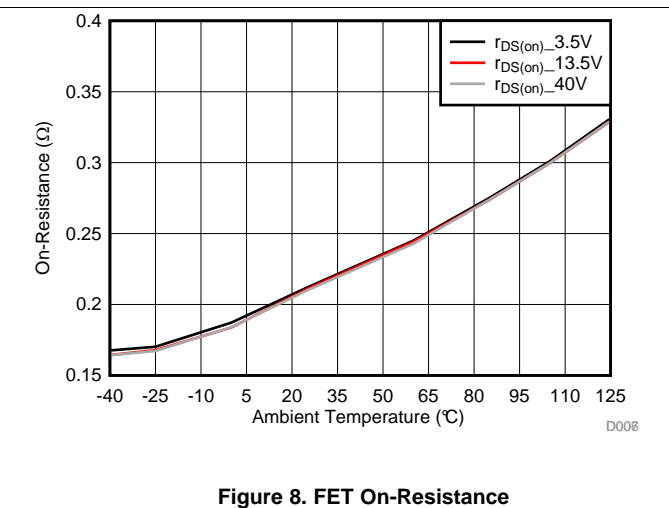

Figure 8. FET On-Resistance

Typical Characteristics (continued)

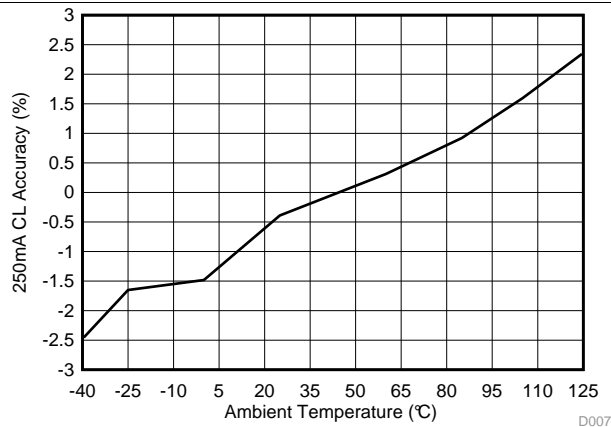

Figure 9. Current-Limit Accuracy at 250 mA

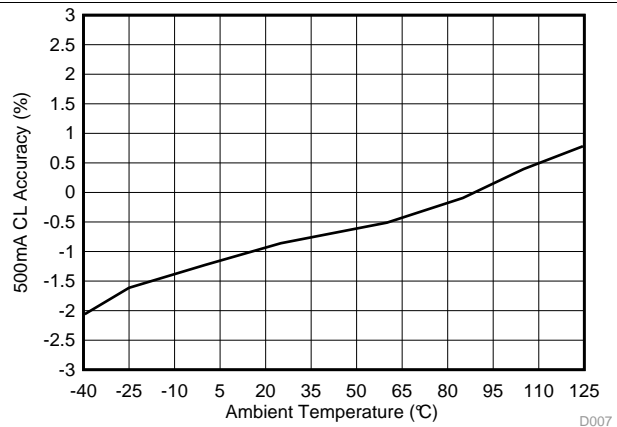

Figure 10. Current-Limit Accuracy at 500 mA

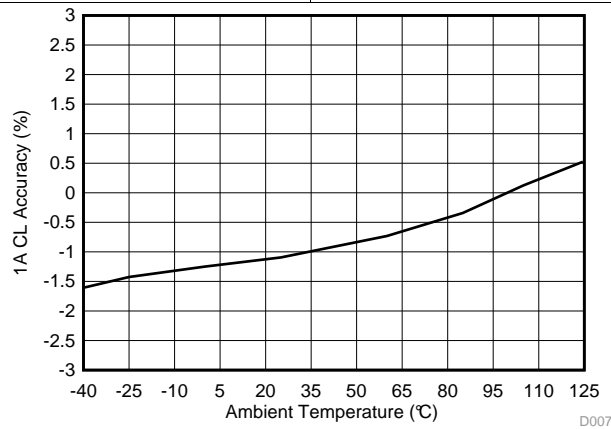

Figure 11. Current-Limit Accuracy at 1 A

7 Detailed Description

7.1 Overview

The TPS1H200A-Q1 device is a smart high-side switch with an internal charge pump and single-channel integrated NMOS power FET. The adjustable current limit function improves the reliability of the whole system. Full diagnostic features enable intelligent control of the load.

The external high-accuracy current limit sets the current limit value for the application. When overcurrent occurs, the device improves system reliability by clamping the inrush current effectively. The device saves system cost by reducing the size of PCB traces and connectors, and the capacity of the preceding power stage. The TPS1H200A-Q1 device allows three modes when a current limit occurs. Users can set the output to consistently hold the current, to immediately latch off, or to automatically retry through the configuration on the DELAY pin. The configurable behaviors during a current limit provides design flexibility. This includes functionality, cost, and thermal dissipation.

This device supports full diagnostics with the digital status output. High-accuracy and low-threshold open-load detection enables real-time ON state monitoring. The device supports operation without an MCU (stand-alone mode) which allows the system to locally implement full functionality.

The TPS1H200A-Q1 device is a smart high-side switch for a wide variety of resistive, inductive, and capacitive loads, including LEDs, bulbs, relays, solenoids, and submodules.

7.2 Functional Block Diagram

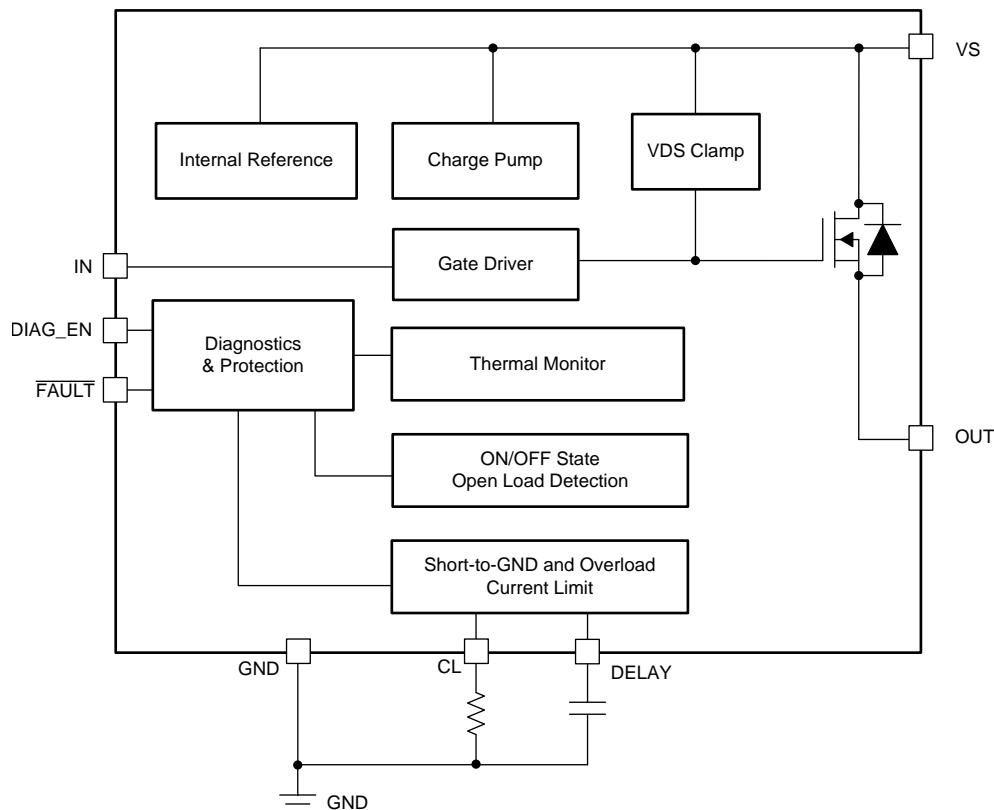

7.3 Feature Description

7.3.1 Current limit

A high-accuracy current limit allows high reliability of the design. The current limit protects the load and the power supply from overstressing during short-circuit-to-GND or power-up conditions. The current limit can also save system cost by reducing the size of PCB traces and connectors, and the capacity of the preceding power stage.

When a current limit threshold is hit, a closed loop immediately activates. The output current is clamped at the set value, and a fault is reported. The device heats up because of high power dissipation on the power FET.

The device has two current limit thresholds.

- **Internal current limit:** The internal current limit is fixed at $I_{CL(int)}$. Tie the CL pin directly to the device GND for large-transient-current applications.
- **External adjustable current limit:** An external resistor is used to set the current limit threshold. Use [Equation 1](#) to calculate $R_{(CL)}$. The external adjustable current limit allows the flexibility to set the current limit value by application.

$$R_{CL} = \frac{V_{CL(th)} \times K_{(CL)}}{I_{OUT}}$$

where

- $V_{CL(th)}$ is the internal band-gap voltage.
- $K_{(CL)}$ is the ratio of the output current and the current limit set value.
- $K_{(CL)}$ is constant across temperature and supply voltage.

(1)

NOTE

When a GND network is used, that causes a level shift between the device GND and board GND, so the CL pin must be connected to the device GND.

For better protection from a hard short-to-GND condition (when the IN pin is enabled, a short-to-GND occurs suddenly), the device will implement a fast-trip protection to turn off the output before the current limit closed loop is set up. Typically, the fast-trip response time is less than 1 μ s. With a fast response like this, the device can achieve a better inrush current-suppression performance.

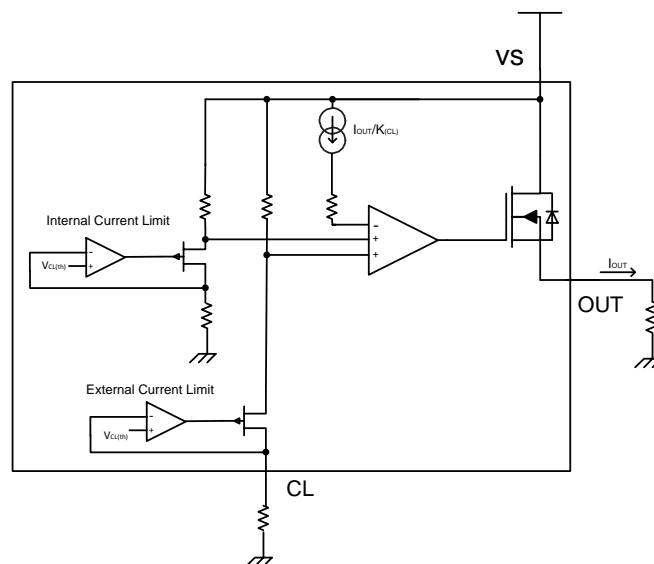

Figure 12. Current Limit

Feature Description (continued)

7.3.2 DELAY Pin Configuration

When a current limit occurs, the TPS1H200A-Q1 device supports three different outcomes of the output. Table 1 lists the current limit configurations and these outcomes behaviors.

Table 1. Current Limit Configurations

| MODE | DELAY CONFIGURATION | OUTPUT CURRENT BEHAVIOR | FAULT RECOVERY |
|------------|-------------------------------------|--|--|
| Holding | Connects to GND directly | When hitting a current limit, the output current holds at the setting current. The device enters into thermal shutdown mode when $T_J > T_{(SD)}$. | $\overline{\text{FAULT}}$ clears when IN turns low for a duration of time longer than $t_{\overline{\text{FAULT}}}$ OR when the current limit is removed when IN is high. |
| Latch-off | Connects to GND through a capacitor | When hitting a current limit, the output current holds at the setting current, but latches off after a preset DELAY time ($t_{dl1} + t_{dl2}$). t_{dl1} is the default delay time, and t_{dl2} is a capacitor-configurable delay time. The output stays latched off regardless of whether the current limit is removed. The output recovers only when IN is toggling. | $\overline{\text{FAULT}}$ clears when IN turns low for a duration of time longer than $t_{\overline{\text{FAULT}}}$. |
| Auto-retry | External pullup | When hitting a current limit, the output current holds at the setting current, but periodically comes on for $t_{hic(on)}$ and turns off for $t_{hic(off)}$. | $\overline{\text{FAULT}}$ clears when IN turns low for a duration of time longer than $t_{\overline{\text{FAULT}}}$ OR when the current limit is removed for $t_{hic(on)}$. |

7.3.2.1 Holding Mode

Holding mode is active when the DELAY pin connects directly to GND. When a current limit is reached, the output current holds at the setting current. The device then enters thermal shutdown mode when $T_J > T_{(SD)}$.

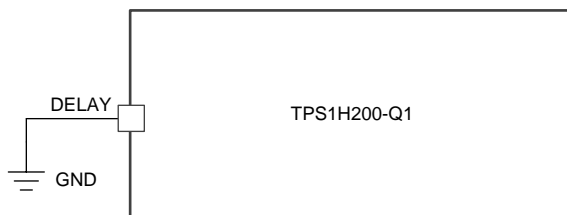

Figure 13. Holding Mode Connection

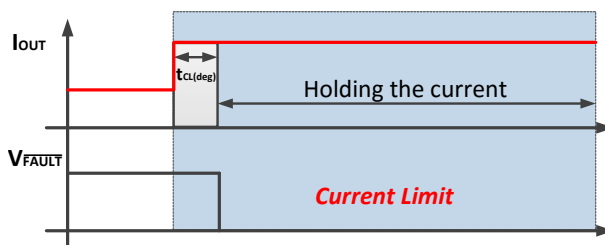

Figure 14. Holding Mode Example

7.3.2.2 Latch-Off Mode

Latch-off mode is active when the DELAY pin connects to GND through a capacitor. When a current limit is reached, the output current holds at the setting current, but latches off after a preset DELAY time ($t_{dl1} + t_{dl2}$). t_{dl1} is the default delay time, and t_{dl2} is a configurable delay time set by a capacitor. Regardless of whether the current limit is removed or not, the output remains latched off. The output only recovers when IN is toggling.

t_{dl2} can be calculated by [Equation 2](#).

$$C_{\text{DELAY}} = \frac{I_{\text{dl(chg)}} \times t_{\text{dl2}}}{V_{\text{dl(ref)}}}$$

where

- C_{DELAY} is the capacitor connected on the DELAY pin.
- The $I_{\text{dl(chg)}}$ is the device that charges the current in latch-off mode.
- t_{dl2} is the user-setting delay time.
- $V_{\text{dl(ref)}}$ is the internal reference voltage in latch-off mode.

(2)

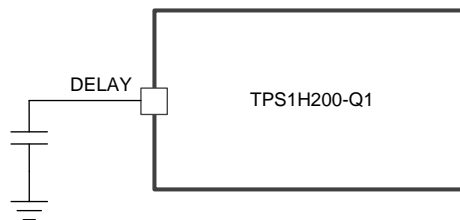

Figure 15. Latch-Off-Mode Connection

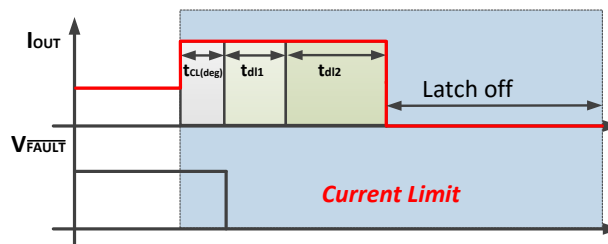

Figure 16. Latch-Off-Mode Example

7.3.2.3 Auto-Retry Mode

Auto-retry mode is active when the DELAY pin is externally pulled up. The pullup voltage must be higher than $V_{dl(th)}$. When the current limit is reached, the output current holds at the setting current, but periodically turns on for $t_{hic(on)}$ and turns off for $t_{hic(off)}$. The device checks the current limit status at the falling edge of $t_{hic(on)}$ clock. If current limit status is captured, the device shuts down for $t_{hic(off)}$. If the current limit status is not captured because of the off window during the thermal conditions, the device keeps turning on for additional $t_{hic(on)}$ or more until the current limit status is captured.

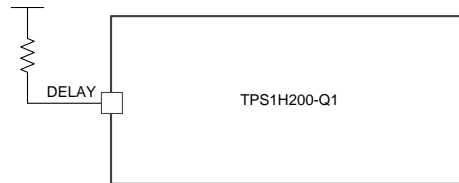

Figure 17. Auto-Retry-Mode Connection

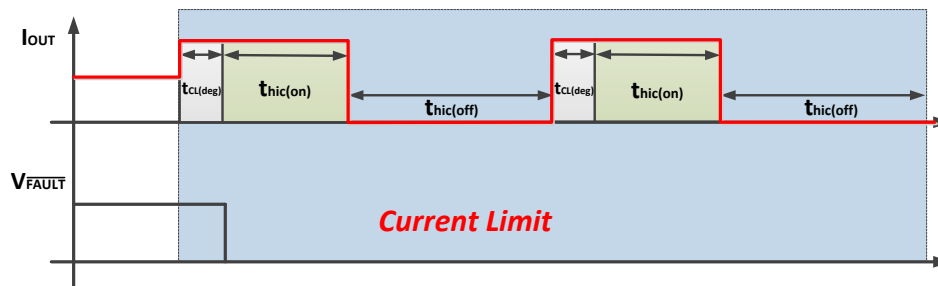

Figure 18. Auto-Retry-Mode Example

7.3.3 Stand-alone Operation

In a typical application, the TPS1H200A-Q1 device is controlled by a microcontroller. The device also supports stand-alone operation. IN and DIAG_EN have a 40-V maximum DC rating, and can be connected to the VS pin directly. When in auto-retry mode, the DELAY pin is connected to the VS pin through a 100-kΩ resistor.

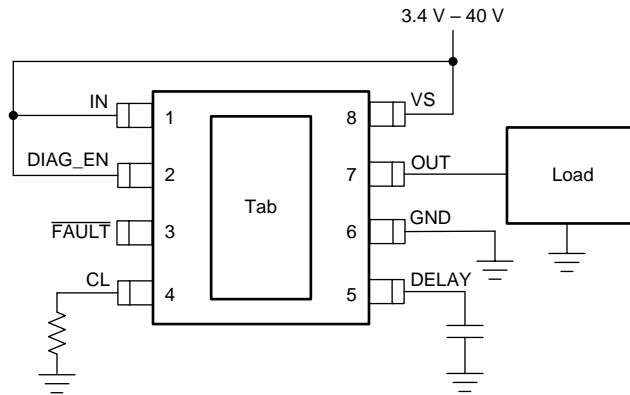

Figure 19. Stand-Alone Operation in Latch-Off Mode

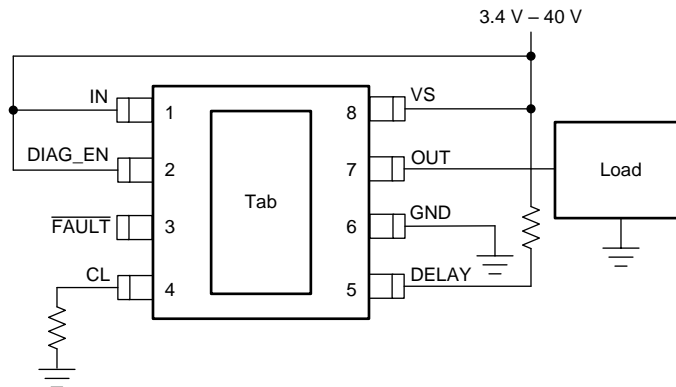

Figure 20. Stand-Alone Operation in Auto-Retry Mode

7.3.4 Fault Truth Table

The DIAG_EN pin enables or disables the diagnostic functions. If multiple devices are used, but the ADC resource is limited in the microcontroller, the microcontroller uses GPIOs to set DIAG_EN high to enable the diagnostics of one device, and disables the diagnostics of the other devices by setting DIAG_EN low. Additionally, the device can keep power consumption to a minimum by setting DIAG_EN and IN low.

Table 2 applies when the DIAG_EN pin is enabled, and Table 3 applies when the DIAG_EN pin is disabled.

Table 2. Fault Truth Table

| CONDITION | IN | OUT | CRITERION | FAULT | FAULT RECOVERY |
|-------------------------------|------------------|-----|-----------------------------------|-------|--|
| Normal | L | L | N/A | H | N/A |
| | H | H | N/A | H | |
| Overload or short to GND | H | L | current limit triggered | L | See Table 1. |
| Open load or short to battery | H | H | $I_{OUT} < I_{(ol,on)}$ | L | $\overline{\text{FAULT}}$ clears when IN turns low for a duration longer than $t_{\overline{\text{FAULT}}}$. OR $\overline{\text{FAULT}}$ clears when the open load is removed. |
| | L ⁽¹⁾ | H | $V_{VS} - V_{OUT} < V_{(ol,off)}$ | L | $\overline{\text{FAULT}}$ clears when IN is toggling OR $\overline{\text{FAULT}}$ clears when the open load is removed. |
| Thermal shutdown | H | N/A | Thermal shutdown triggered | L | $\overline{\text{FAULT}}$ clears when IN turns low for a duration longer than $t_{\overline{\text{FAULT}}}$. OR $\overline{\text{FAULT}}$ clears when thermal shutdown quits. |
| Thermal swing | H | N/A | Thermal swing triggered | L | $\overline{\text{FAULT}}$ clears when IN turns low for a duration longer than $t_{\overline{\text{FAULT}}}$. OR $\overline{\text{FAULT}}$ clears when thermal swing quits. |

(1) An external pullup is required for open-load detection.

Table 3. DIAG_EN Disabled Condition

| DIAG_EN | IN CONDITION | PROTECTIONS AND DIAGNOSTICS |
|---------|--------------|--|
| LOW | ON | Diagnostics disabled, full protections |
| | OFF | Diagnostics disabled, no protection |

7.3.5 Full Diagnostics

7.3.5.1 Short-to-GND and Overload Detection

When the output is on, a short-to-GND or overload condition causes an overcurrent. If the overcurrent triggers the internal or external current limit threshold, the fault condition is reported as $\overline{\text{FAULT}}$ pin = low.

7.3.5.2 Open-Load Detection

7.3.5.2.1 Output On

When the output is on, the device recognizes an open-load fault if the current flowing through the output $I_{OUT} < I_{(ol,on)}$. For open-load detection when output is on, no external circuitry is required.

7.3.5.2.2 Output Off

When the output is off, the output is pulled down to GND if a load is connected. But if an open load occurs, the output voltage is close to the supply voltage ($V_{VS} - V_{OUT} < V_{(ol,off)}$), and the device recognizes an open-load fault.

There is always a leakage current $I_{(ol,off)}$ on the output due to the internal logic control path or external humidity, corrosion, and so forth. As a result, TI recommends using an external pullup resistor to offset the leakage current when an open load is detected. The recommended pullup resistance is 15 k Ω .

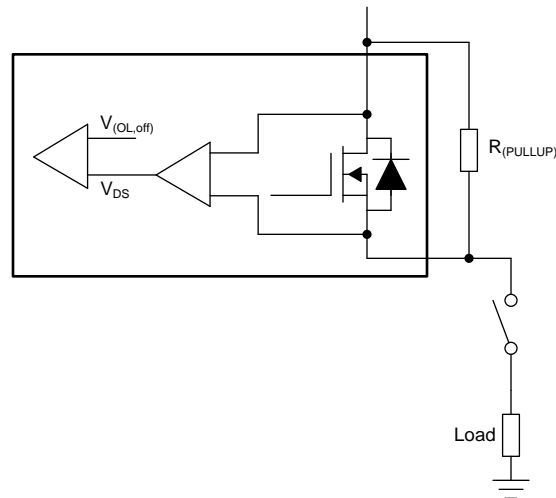

Figure 21. Open-Load Detection in Output OFF State

7.3.5.3 Short-to-Battery Detection

Short-to-battery has the same detection mechanism and behavior as open-load detection in the ON state and the OFF state.

7.3.5.4 Thermal Fault Detection

To protect the device in severe power stressing cases, the device implements two types of thermal fault detection, absolute temperature protection (thermal shutdown) and dynamic temperature protection (thermal swing).

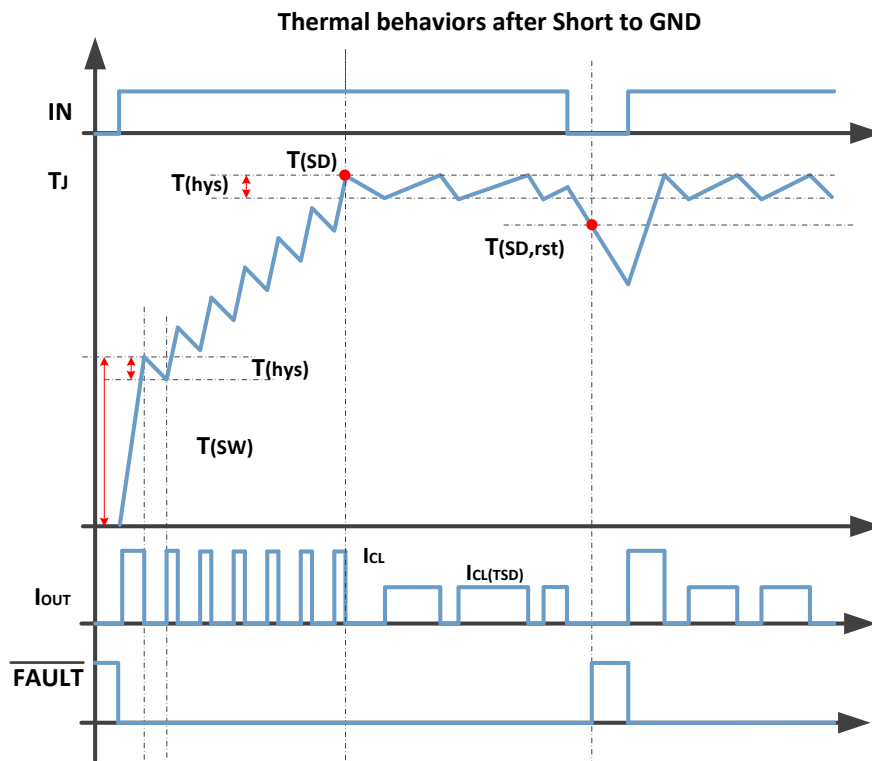

Figure 22. Thermal Behavior Diagram

7.3.5.4.1 Thermal Shutdown

Thermal shutdown is active when the absolute temperature $T_J > T_{(SD)}$. When thermal shutdown occurs, the output turns off.

7.3.5.4.2 Thermal Swing

Thermal swing activates when the power FET temperature sharply increases, that is, when $\Delta T = T_{(FET)} - T_{(Logic)} > T_{(sw)}$, then the output turns off. The output automatically recovers and the fault signal clears when $\Delta T = T_{(FET)} - T_{(Logic)} < T_{(sw)} - T_{(hys)}$. The thermal swing function improves the reliability of the device when subjected to repetitively fast thermal variation.

7.3.5.4.3 Fault Report Holding

When using PWM dimming, \overline{FAULT} is easily cleared by the PWM falling edge. Even if the fault condition remains all the time, \overline{FAULT} is discontinuous. To avoid this unexpected fault report behavior, the device implements fault report holding time. Figure 23 shows an issue that typically occurs during PWM dimming, the \overline{FAULT} is cleared unexpectedly even when the short-to-GND still exists. The TPS1H200A-Q1 device with fault-report holding function allows the right behavior as shown in Figure 24.

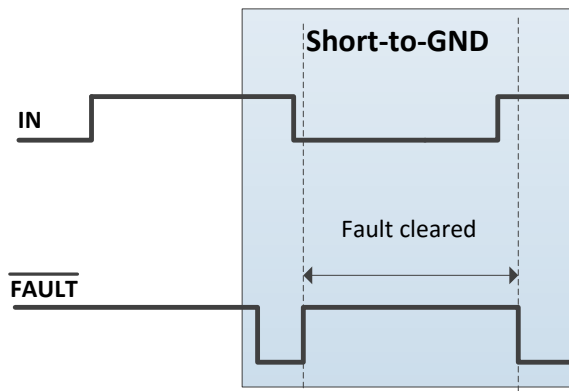
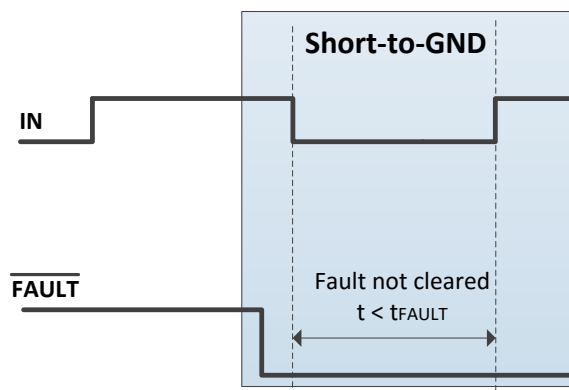
Figure 23. Without Fault-Report Holding

Figure 24. With Fault-Report Holding

7.3.6 Full Protections

7.3.6.1 UVLO Protection

The device monitors the supply voltage, V_{VS} , to prevent unpredicted behaviors when V_{VS} is too low. When V_{VS} drops down to $V_{VS(uvf)}$, the device shuts down. When V_{VS} rises up to $V_{VS(uvr)}$, the device turns on.

7.3.6.2 Inductive Load Switching Off Clamp

When an inductive load is switched off, the inductive reactance pulls the output voltage negative. However, excessive negative voltage can cause the power FET to break down. To protect the power FET from breaking down, an internal clamp ($V_{DS(clamp)}$) is implemented.

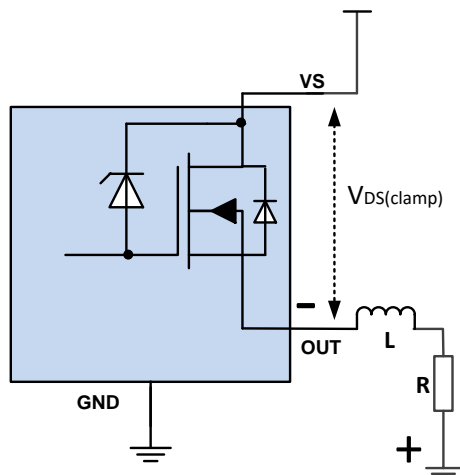

Figure 25. Drain-to-Source Clamping Structure

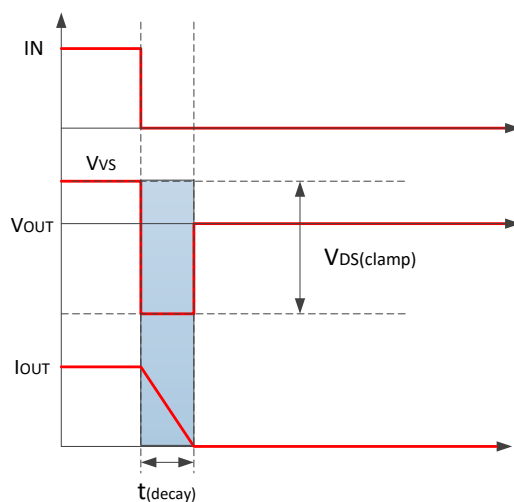

Figure 26. Inductive-Load Switching-Off Diagram

7.3.6.3 Loss-of-GND Protection

When a loss-of-GND occurs, the output shuts down, regardless of whether the IN pin is high or low. The device can protect against two ground-loss conditions, loss of device GND and loss of module GND.

7.3.6.4 Loss-of-Power-Supply Protection

When a loss-of-power-supply occurs, the output shuts down, regardless of whether the IN pin is high or low. For a resistive or a capacitive load, the loss-of-power-supply has no risk. But for a charged inductive load, the current is driven from all the logic control pins to maintain the inductance current. To protect the system in this condition, TI recommends protection with an external free-wheeling diode.

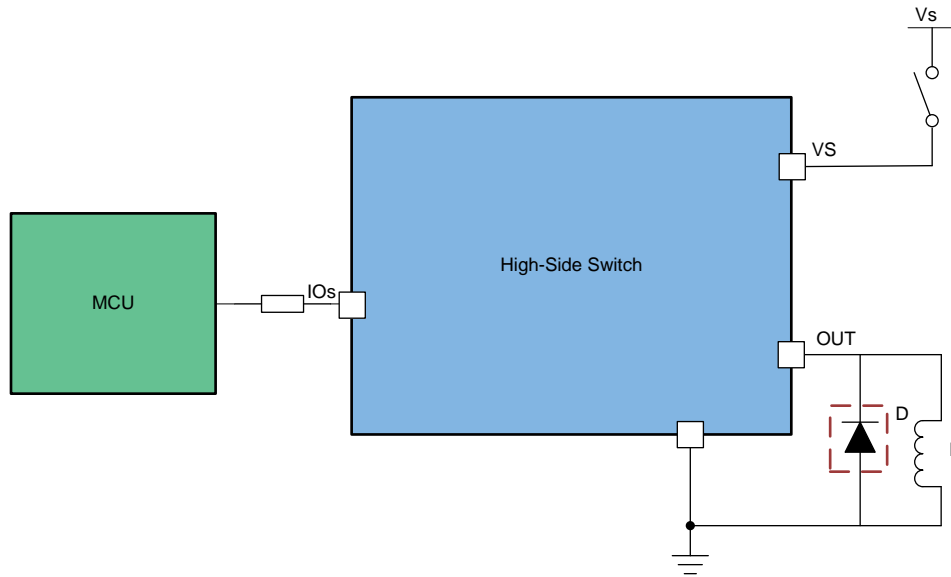

Figure 27. Protection for Loss of Power Supply

7.3.6.5 Reverse-Current Protection

Reverse current occurs in two conditions: short to supply and reverse polarity.

- When a short to the supply occurs, there is only reverse current through the body diode. $I_{R(1)}$ specifies the limit of the reverse current.
- In a reverse-polarity condition, there are reverse currents through the body diode and the device GND pin. $I_{R(2)}$ specifies the limit of the reverse current.

To protect the device, TI recommends using two types of external circuitry.

- Adding a blocking diode (method 1). The device and load are protected when in reverse polarity.
- Adding a GND network (method 2). The reverse current through the device GND is blocked. The reverse current through the FET is limited by the load itself. TI recommends a resistor in parallel with the diode as a GND network. The recommended configuration is a 1-k Ω resistor in parallel with a diode that is less than 100 mA.

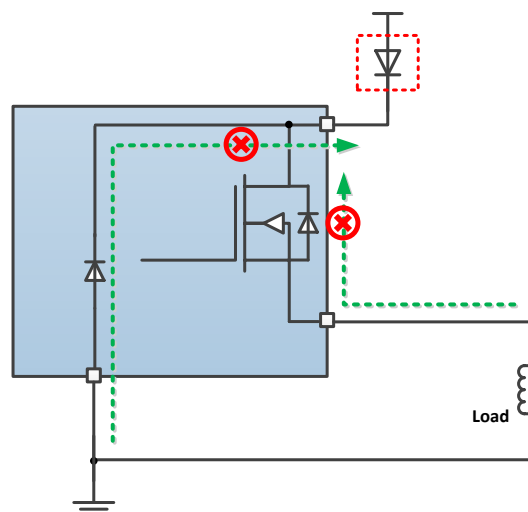

Figure 28. Reverse-Current External Protection Method 1

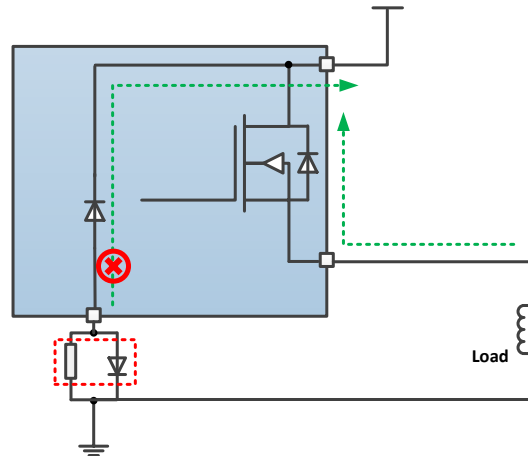

Figure 29. Reverse-Current External Protection Method 2

7.3.6.6 MCU I/O Protection

TI recommends using series resistors to protect the microcontroller, for example, 4.7-k Ω when using a 3.3-V microcontroller and 10-k Ω for a 5-V microcontroller.

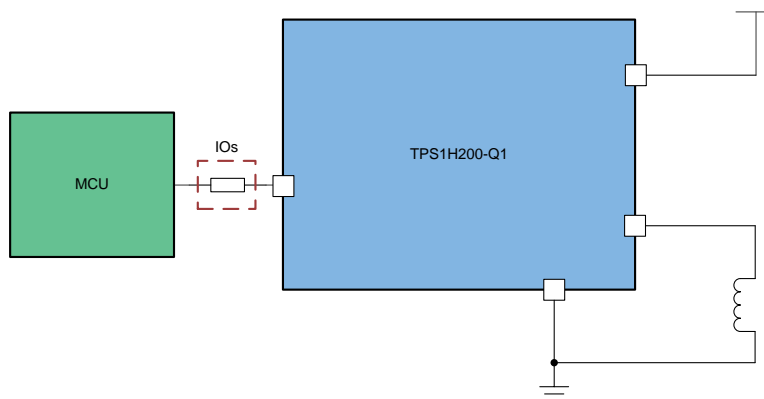

Figure 30. MCU I/O External Protection

7.4 Device Functional Modes

7.4.1 Working Modes

The device has three working modes, the normal mode, the standby mode, and the standby mode with diagnostics, as shown in [Figure 31](#).

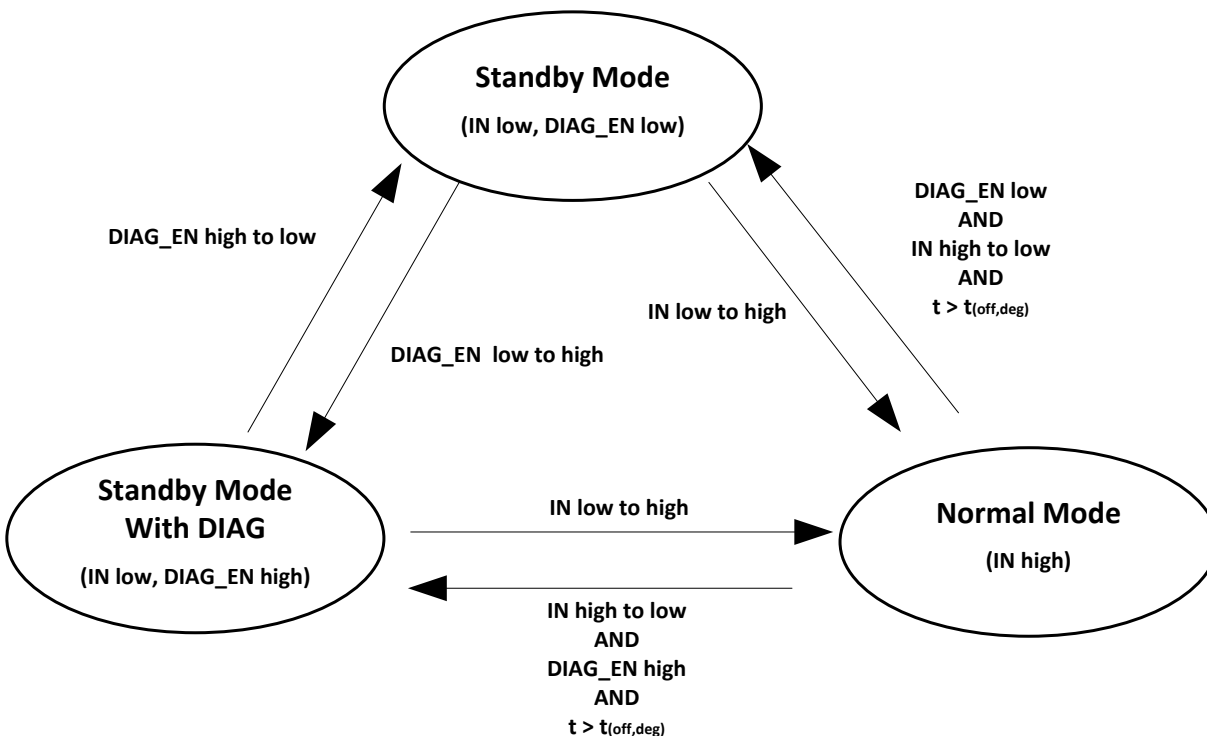

Figure 31. Working Modes

7.4.1.1 Normal Mode

When IN is high, the device enters normal mode.

7.4.1.2 Standby Mode

When IN is high and DIAG_EN is high, the device enters standby mode with ultra-low power consumption.

7.4.1.3 Standby Mode With Diagnostics

When IN is low and DIAG_EN is high, the device enters standby mode with diagnostics. The device still supports open-load and short-to-battery detection even when IN is low.

8 Application and Implementation

NOTE

Information in the following applications sections is not part of the TI component specification, and TI does not warrant its accuracy or completeness. TI's customers are responsible for determining suitability of components for their purposes. Customers should validate and test their design implementation to confirm system functionality.

8.1 Application Information

The TPS1H200A-Q1 device is a smart high-side switch, with an internal charge pump and single-channel integrated NMOS power FET. The adjustable current limit function greatly improves the reliability of the whole system. Full diagnostic features enable intelligent control of the load. The TPS1H200A-Q1 device applies for a wide variety of resistive, inductive, and capacitive loads, including LEDs, relays, and submodules.

8.2 Typical Application

Figure 32 shows an example of how to design the external circuitry parameters.

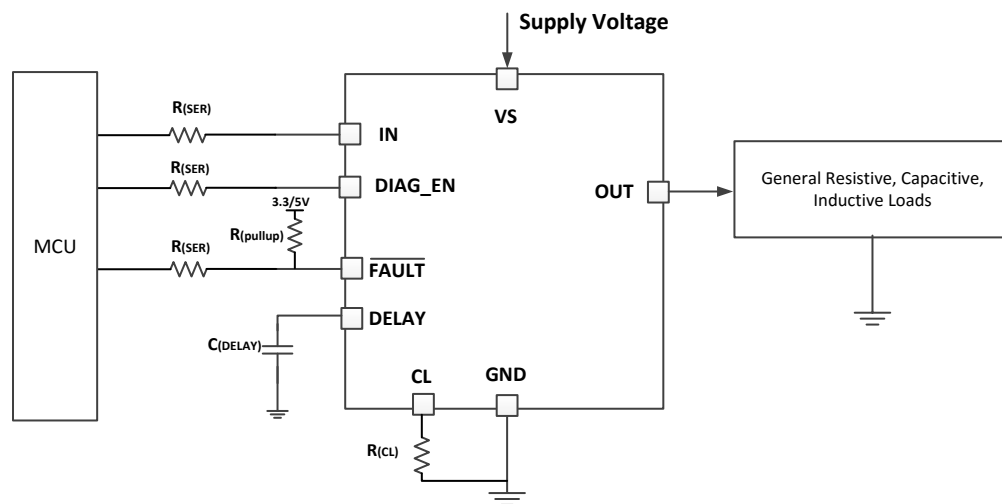

Figure 32. Typical Application Circuitry

8.2.1 Design Requirements

- V_{VS} range from 6 V to 18 V
- Nominal current of 500 mA
- Expected current limit value of 2 A
- Thermal sensitive system. When current limit occurs, the output latches off after 0.2 seconds. The 0.2 seconds is to ensure the safe start-up for a capacitive load, clamping the inrush current but without latch-off during start-up.
- Full diagnostics with 5-V MCU, including ON state open-load detection, short-to-GND, or overcurrent detection, and thermal shutdown detection

Typical Application (continued)

8.2.2 Detailed Design Procedure

To set the adjustable current limit value at 2 A, calculate $R_{(CL)}$ as follows:

$$R_{(CL)} = \frac{V_{CL(th)} \times K_{(CL)}}{I_{OUT}} = \frac{0.8 \times 2500}{2} = 1000 \Omega \tag{3}$$

To set the adjustable latch-off delay at 0.2 s, calculate $C_{(DELAY)}$ as follows:

$$t_{dl} = t_{CL(deg)} + t_{dl1} + t_{dl2} = 0.2 \gg t_{dl2}$$

$$C_{DELAY} = \frac{I_{dl(chg)} \times t_{dl2}}{V_{dl(ref)}} = \frac{4.5 \times 0.2}{1.45} \times 10^{-6} = 0.62 \mu F \tag{4}$$

TI recommends $R_{(SER)} = 10 \text{ k}\Omega$ for a 5-V MCU, and $R_{(pullup)} = 10 \text{ k}\Omega$ as the pullup resistor.

8.2.3 Application Curves

The following curves are test examples of hard-short conditions. The load is 0.1 A and the current limit value is 0.6 A. [Figure 33](#) shows a waveform of the latch-off mode. [Figure 34](#) shows a waveform of the auto-retry mode.

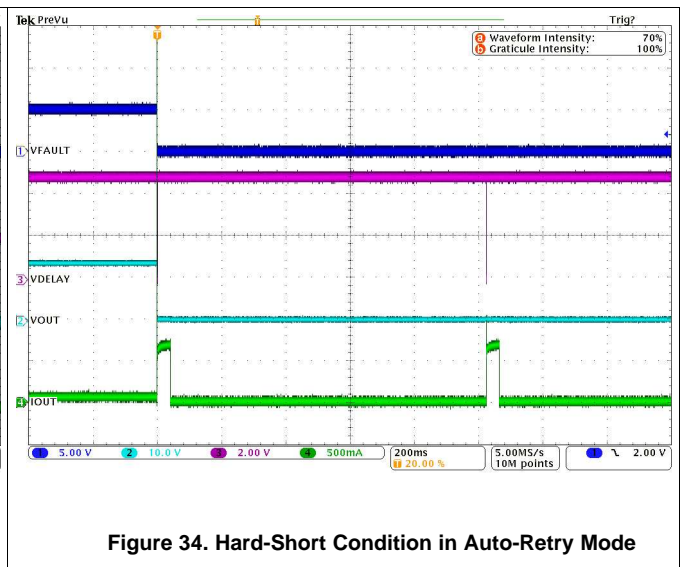
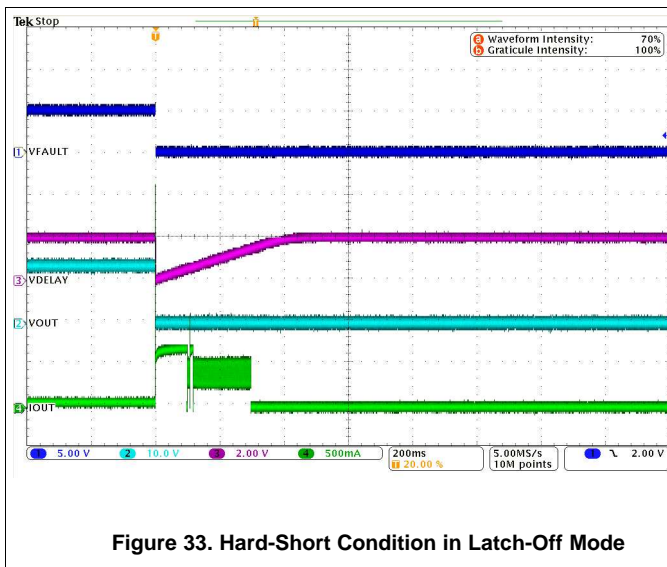

9 Power Supply Recommendations

The device applies to 12-V and 24-V applications. The normal power supply connection is a 12-V or 24-V system.

10 Layout

10.1 Layout Guidelines

To prevent thermal shutdown, T_J must be less than 175°C. If the output current is high, the power dissipation may be large. However, the PCB layout is very important. A good PCB design optimizes heat transfer, which is essential for the long-term reliability of the device.

- Maximize the copper coverage on the PCB to increase the thermal conductivity of the board. The major heat-flow path from the package to the ambient is through the copper on the PCB. Maximum copper is extremely important when no heat sinks are attached to the PCB on the other side of the board opposite the package.
- Add as many thermal vias as possible directly under the package ground pad to optimize the thermal conductivity of the board.
- All thermal vias should either be plated shut or plugged and capped on both sides of the board to prevent solder voids. To ensure reliability and performance, the solder coverage must be at least 85%.

10.2 Layout Example

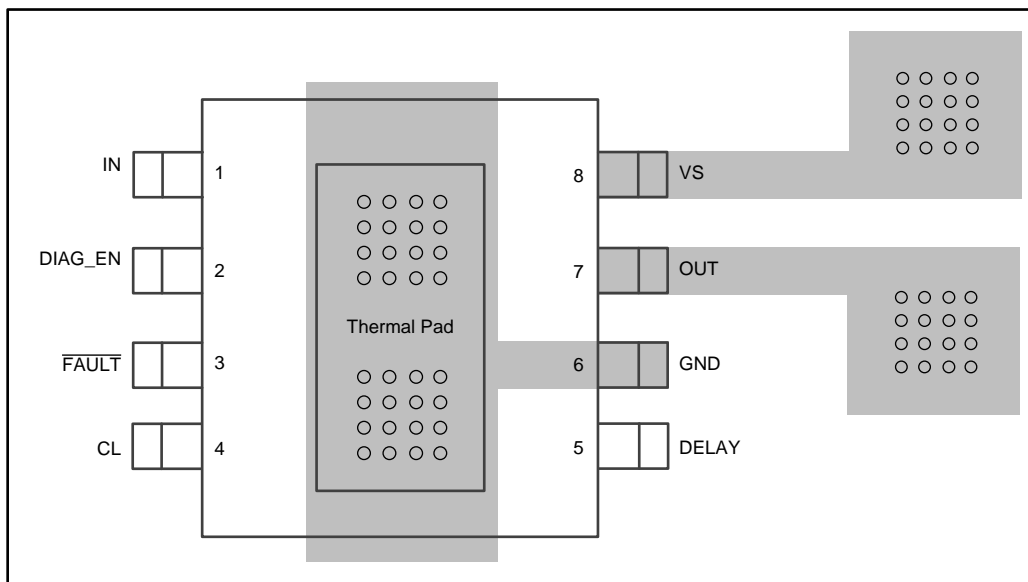

Figure 35. Layout Example

11 Device and Documentation Support

11.1 Documentation Support

11.1.1 Related Documentation

For related documentation see the following:

- Texas Instruments, [TPS1H000-Q1 Evaluation Module \(EVM\) User's Guide](#)

11.2 Receiving Notification of Documentation Updates

To receive notification of documentation updates, navigate to the device product folder on ti.com. In the upper-right corner, click on *Alert me* to register and receive a weekly digest of any product information that has changed. For change details, review the revision history included in any revised document.

11.3 Community Resources

The following links connect to TI community resources. Linked contents are provided "AS IS" by the respective contributors. They do not constitute TI specifications and do not necessarily reflect TI's views; see TI's [Terms of Use](#).

TI E2E™ Online Community *TI's Engineer-to-Engineer (E2E) Community*. Created to foster collaboration among engineers. At e2e.ti.com, you can ask questions, share knowledge, explore ideas and help solve problems with fellow engineers.

Design Support *TI's Design Support* Quickly find helpful E2E forums along with design support tools and contact information for technical support.

11.4 Trademarks

PowerPAD, E2E are trademarks of Texas Instruments.
All other trademarks are the property of their respective owners.

11.5 Electrostatic Discharge Caution



This integrated circuit can be damaged by ESD. Texas Instruments recommends that all integrated circuits be handled with appropriate precautions. Failure to observe proper handling and installation procedures can cause damage.

ESD damage can range from subtle performance degradation to complete device failure. Precision integrated circuits may be more susceptible to damage because very small parametric changes could cause the device not to meet its published specifications.

11.6 Glossary

SLYZ022 — *TI Glossary*.

This glossary lists and explains terms, acronyms, and definitions.

12 Mechanical, Packaging, and Orderable Information

The following pages include mechanical, packaging, and orderable information. This information is the most current data available for the designated devices. This data is subject to change without notice and revision of this document. For browser-based versions of this data sheet, refer to the left-hand navigation.

PACKAGING INFORMATION

| Orderable Device | Status (1) | Package Type | Package Drawing | Pins | Package Qty | Eco Plan (2) | Lead/Ball Finish (6) | MSL Peak Temp (3) | Op Temp (°C) | Device Marking (4/5) | Samples |
|------------------|---------------|---------------|-----------------|------|-------------|-------------------------|-------------------------|----------------------|--------------|-------------------------|-------------------------|
| TPS1H200AQDGNRQ1 | ACTIVE | MSOP-PowerPAD | DGN | 8 | 2500 | Green (RoHS & no Sb/Br) | CU NIPDAUAG | Level-2-260C-1 YEAR | -40 to 125 | 1EWX | Samples |

(1) The marketing status values are defined as follows:

ACTIVE: Product device recommended for new designs.

LIFEBUY: TI has announced that the device will be discontinued, and a lifetime-buy period is in effect.

NRND: Not recommended for new designs. Device is in production to support existing customers, but TI does not recommend using this part in a new design.

PREVIEW: Device has been announced but is not in production. Samples may or may not be available.

OBSOLETE: TI has discontinued the production of the device.

(2) **RoHS:** TI defines "RoHS" to mean semiconductor products that are compliant with the current EU RoHS requirements for all 10 RoHS substances, including the requirement that RoHS substance do not exceed 0.1% by weight in homogeneous materials. Where designed to be soldered at high temperatures, "RoHS" products are suitable for use in specified lead-free processes. TI may reference these types of products as "Pb-Free".

RoHS Exempt: TI defines "RoHS Exempt" to mean products that contain lead but are compliant with EU RoHS pursuant to a specific EU RoHS exemption.

Green: TI defines "Green" to mean the content of Chlorine (Cl) and Bromine (Br) based flame retardants meet JS709B low halogen requirements of <=1000ppm threshold. Antimony trioxide based flame retardants must also meet the <=1000ppm threshold requirement.

(3) MSL, Peak Temp. - The Moisture Sensitivity Level rating according to the JEDEC industry standard classifications, and peak solder temperature.

(4) There may be additional marking, which relates to the logo, the lot trace code information, or the environmental category on the device.

(5) Multiple Device Markings will be inside parentheses. Only one Device Marking contained in parentheses and separated by a "~" will appear on a device. If a line is indented then it is a continuation of the previous line and the two combined represent the entire Device Marking for that device.

(6) Lead/Ball Finish - Orderable Devices may have multiple material finish options. Finish options are separated by a vertical ruled line. Lead/Ball Finish values may wrap to two lines if the finish value exceeds the maximum column width.

Important Information and Disclaimer:The information provided on this page represents TI's knowledge and belief as of the date that it is provided. TI bases its knowledge and belief on information provided by third parties, and makes no representation or warranty as to the accuracy of such information. Efforts are underway to better integrate information from third parties. TI has taken and continues to take reasonable steps to provide representative and accurate information but may not have conducted destructive testing or chemical analysis on incoming materials and chemicals. TI and TI suppliers consider certain information to be proprietary, and thus CAS numbers and other limited information may not be available for release.

In no event shall TI's liability arising out of such information exceed the total purchase price of the TI part(s) at issue in this document sold by TI to Customer on an annual basis.

TAPE AND REEL INFORMATION



QUADRANT ASSIGNMENTS FOR PIN 1 ORIENTATION IN TAPE



*All dimensions are nominal

| Device | Package Type | Package Drawing | Pins | SPQ | Reel Diameter (mm) | Reel Width W1 (mm) | A0 (mm) | B0 (mm) | K0 (mm) | P1 (mm) | W (mm) | Pin1 Quadrant |
|------------------|----------------|-----------------|------|------|--------------------|--------------------|---------|---------|---------|---------|--------|---------------|
| TPS1H200AQDGNRQ1 | MSOP-Power PAD | DGN | 8 | 2500 | 330.0 | 12.4 | 5.3 | 3.4 | 1.4 | 8.0 | 12.0 | Q1 |

TAPE AND REEL BOX DIMENSIONS



*All dimensions are nominal

| Device | Package Type | Package Drawing | Pins | SPQ | Length (mm) | Width (mm) | Height (mm) |
|------------------|---------------|-----------------|------|------|-------------|------------|-------------|
| TPS1H200AQDGNRQ1 | MSOP-PowerPAD | DGN | 8 | 2500 | 366.0 | 364.0 | 50.0 |

DGN (S-PDSO-G8)

PowerPAD™ PLASTIC SMALL OUTLINE



- NOTES:
- All linear dimensions are in millimeters.
 - This drawing is subject to change without notice.
 - Body dimensions do not include mold flash or protrusion.
 - This package is designed to be soldered to a thermal pad on the board. Refer to Technical Brief, PowerPad Thermally Enhanced Package, Texas Instruments Literature No. SLMA002 for information regarding recommended board layout. This document is available at www.ti.com <<http://www.ti.com>>.
 - See the additional figure in the Product Data Sheet for details regarding the exposed thermal pad features and dimensions.
 - Falls within JEDEC MO-187 variation AA-T

PowerPAD is a trademark of Texas Instruments.

DGN (S-PDSO-G8)

PowerPAD™ PLASTIC SMALL OUTLINE

THERMAL INFORMATION

This PowerPAD™ package incorporates an exposed thermal pad that is designed to be attached to a printed circuit board (PCB). The thermal pad must be soldered directly to the PCB. After soldering, the PCB can be used as a heatsink. In addition, through the use of thermal vias, the thermal pad can be attached directly to the appropriate copper plane shown in the electrical schematic for the device, or alternatively, can be attached to a special heatsink structure designed into the PCB. This design optimizes the heat transfer from the integrated circuit (IC).

For additional information on the PowerPAD package and how to take advantage of its heat dissipating abilities, refer to Technical Brief, PowerPAD Thermally Enhanced Package, Texas Instruments Literature No. SLMA002 and Application Brief, PowerPAD Made Easy, Texas Instruments Literature No. SLMA004. Both documents are available at www.ti.com.

The exposed thermal pad dimensions for this package are shown in the following illustration.

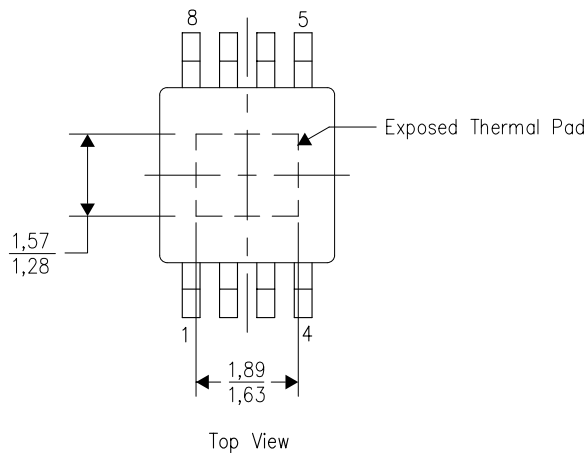

Exposed Thermal Pad Dimensions

4206323-2/1 12/11

NOTE: All linear dimensions are in millimeters

PowerPAD is a trademark of Texas Instruments



- NOTES:
- A. All linear dimensions are in millimeters.
 - B. This drawing is subject to change without notice.
 - C. Customers should place a note on the circuit board fabrication drawing not to alter the center solder mask defined pad.
 - D. This package is designed to be soldered to a thermal pad on the board. Refer to Technical Brief, PowerPad Thermally Enhanced Package, Texas Instruments Literature No. SLMA002, SLMA004, and also the Product Data Sheets for specific thermal information, via requirements, and recommended board layout. These documents are available at www.ti.com <<http://www.ti.com>>.
 - E. Laser cutting apertures with trapezoidal walls and also rounding corners will offer better paste release. Customers should contact their board assembly site for stencil design recommendations. Example stencil design based on a 50% volumetric metal load solder paste. Refer to IPC-7525 for other stencil recommendations.
 - F. Customers should contact their board fabrication site for solder mask tolerances between and around signal pads.

PowerPAD is a trademark of Texas Instruments

IMPORTANT NOTICE

Texas Instruments Incorporated (TI) reserves the right to make corrections, enhancements, improvements and other changes to its semiconductor products and services per JESD46, latest issue, and to discontinue any product or service per JESD48, latest issue. Buyers should obtain the latest relevant information before placing orders and should verify that such information is current and complete.

TI's published terms of sale for semiconductor products (<http://www.ti.com/sc/docs/stdterms.htm>) apply to the sale of packaged integrated circuit products that TI has qualified and released to market. Additional terms may apply to the use or sale of other types of TI products and services.

Reproduction of significant portions of TI information in TI data sheets is permissible only if reproduction is without alteration and is accompanied by all associated warranties, conditions, limitations, and notices. TI is not responsible or liable for such reproduced documentation. Information of third parties may be subject to additional restrictions. Resale of TI products or services with statements different from or beyond the parameters stated by TI for that product or service voids all express and any implied warranties for the associated TI product or service and is an unfair and deceptive business practice. TI is not responsible or liable for any such statements.

Buyers and others who are developing systems that incorporate TI products (collectively, "Designers") understand and agree that Designers remain responsible for using their independent analysis, evaluation and judgment in designing their applications and that Designers have full and exclusive responsibility to assure the safety of Designers' applications and compliance of their applications (and of all TI products used in or for Designers' applications) with all applicable regulations, laws and other applicable requirements. Designer represents that, with respect to their applications, Designer has all the necessary expertise to create and implement safeguards that (1) anticipate dangerous consequences of failures, (2) monitor failures and their consequences, and (3) lessen the likelihood of failures that might cause harm and take appropriate actions. Designer agrees that prior to using or distributing any applications that include TI products, Designer will thoroughly test such applications and the functionality of such TI products as used in such applications.

TI's provision of technical, application or other design advice, quality characterization, reliability data or other services or information, including, but not limited to, reference designs and materials relating to evaluation modules, (collectively, "TI Resources") are intended to assist designers who are developing applications that incorporate TI products; by downloading, accessing or using TI Resources in any way, Designer (individually or, if Designer is acting on behalf of a company, Designer's company) agrees to use any particular TI Resource solely for this purpose and subject to the terms of this Notice.

TI's provision of TI Resources does not expand or otherwise alter TI's applicable published warranties or warranty disclaimers for TI products, and no additional obligations or liabilities arise from TI providing such TI Resources. TI reserves the right to make corrections, enhancements, improvements and other changes to its TI Resources. TI has not conducted any testing other than that specifically described in the published documentation for a particular TI Resource.

Designer is authorized to use, copy and modify any individual TI Resource only in connection with the development of applications that include the TI product(s) identified in such TI Resource. NO OTHER LICENSE, EXPRESS OR IMPLIED, BY ESTOPPEL OR OTHERWISE TO ANY OTHER TI INTELLECTUAL PROPERTY RIGHT, AND NO LICENSE TO ANY TECHNOLOGY OR INTELLECTUAL PROPERTY RIGHT OF TI OR ANY THIRD PARTY IS GRANTED HEREIN, including but not limited to any patent right, copyright, mask work right, or other intellectual property right relating to any combination, machine, or process in which TI products or services are used. Information regarding or referencing third-party products or services does not constitute a license to use such products or services, or a warranty or endorsement thereof. Use of TI Resources may require a license from a third party under the patents or other intellectual property of the third party, or a license from TI under the patents or other intellectual property of TI.

TI RESOURCES ARE PROVIDED "AS IS" AND WITH ALL FAULTS. TI DISCLAIMS ALL OTHER WARRANTIES OR REPRESENTATIONS, EXPRESS OR IMPLIED, REGARDING RESOURCES OR USE THEREOF, INCLUDING BUT NOT LIMITED TO ACCURACY OR COMPLETENESS, TITLE, ANY EPIDEMIC FAILURE WARRANTY AND ANY IMPLIED WARRANTIES OF MERCHANTABILITY, FITNESS FOR A PARTICULAR PURPOSE, AND NON-INFRINGEMENT OF ANY THIRD PARTY INTELLECTUAL PROPERTY RIGHTS. TI SHALL NOT BE LIABLE FOR AND SHALL NOT DEFEND OR INDEMNIFY DESIGNER AGAINST ANY CLAIM, INCLUDING BUT NOT LIMITED TO ANY INFRINGEMENT CLAIM THAT RELATES TO OR IS BASED ON ANY COMBINATION OF PRODUCTS EVEN IF DESCRIBED IN TI RESOURCES OR OTHERWISE. IN NO EVENT SHALL TI BE LIABLE FOR ANY ACTUAL, DIRECT, SPECIAL, COLLATERAL, INDIRECT, PUNITIVE, INCIDENTAL, CONSEQUENTIAL OR EXEMPLARY DAMAGES IN CONNECTION WITH OR ARISING OUT OF TI RESOURCES OR USE THEREOF, AND REGARDLESS OF WHETHER TI HAS BEEN ADVISED OF THE POSSIBILITY OF SUCH DAMAGES.

Unless TI has explicitly designated an individual product as meeting the requirements of a particular industry standard (e.g., ISO/TS 16949 and ISO 26262), TI is not responsible for any failure to meet such industry standard requirements.

Where TI specifically promotes products as facilitating functional safety or as compliant with industry functional safety standards, such products are intended to help enable customers to design and create their own applications that meet applicable functional safety standards and requirements. Using products in an application does not by itself establish any safety features in the application. Designers must ensure compliance with safety-related requirements and standards applicable to their applications. Designer may not use any TI products in life-critical medical equipment unless authorized officers of the parties have executed a special contract specifically governing such use. Life-critical medical equipment is medical equipment where failure of such equipment would cause serious bodily injury or death (e.g., life support, pacemakers, defibrillators, heart pumps, neurostimulators, and implantables). Such equipment includes, without limitation, all medical devices identified by the U.S. Food and Drug Administration as Class III devices and equivalent classifications outside the U.S.

TI may expressly designate certain products as completing a particular qualification (e.g., Q100, Military Grade, or Enhanced Product). Designers agree that it has the necessary expertise to select the product with the appropriate qualification designation for their applications and that proper product selection is at Designers' own risk. Designers are solely responsible for compliance with all legal and regulatory requirements in connection with such selection.

Designer will fully indemnify TI and its representatives against any damages, costs, losses, and/or liabilities arising out of Designer's non-compliance with the terms and provisions of this Notice.