

# TMUX1109 5 V, ±2.5 V, Low-Leakage-Current, 4:1, 2-Channel Precision Multiplexer

## 1 Features

- Single Supply Range: 1.08 V to 5.5 V
- Dual Supply Range: ±2.75 V
- Low Leakage Current: 3 pA
- Low Charge Injection: 1 pC
- Low On-Resistance: 1.8 Ω
- -40°C to +125°C Operating Temperature
- [1.8 V Logic Compatible](#)
- [Fail-Safe Logic](#)
- [Rail to Rail Operation](#)
- [Bidirectional Signal Path](#)
- Break-Before-Make Switching
- ESD Protection HBM: 2000 V

## 2 Applications

- Ultrasound Scanners
- Patient Monitoring & Diagnostics
- Optical Networking
- Optical Test Equipment
- Remote Radio Unit
- Wired Networking
- ATE Test Equipment
- Factory Automation and Industrial Controls
- Programmable Logic Controllers (PLC)
- Analog Input Modules
- SONAR Receivers
- Motor Drive
- Servo Drive Position Feedback

## 3 Description

The TMUX1109 is a precision complementary metal-oxide semiconductor (CMOS) multiplexer (MUX). The TMUX1109 offers differential 4:1 or dual 4:1 single-ended channels. Wide operating supply of 1.08 V to 5.5 V allows for use in a broad array of applications from medical equipment to industrial systems. The device supports bidirectional analog and digital signals on the source (Sx) and drain (D) pins ranging from GND to V<sub>DD</sub>. All logic inputs have [1.8 V logic compatible](#) thresholds, ensuring both TTL and CMOS logic compatibility when operating in the valid supply voltage range. [Fail-Safe Logic](#) circuitry allows voltages on the control pins to be applied before the supply pin, protecting the device from potential damage.

The TMUX1109 is part of the precision switches and multiplexers family of devices. These devices have very low on and off leakage currents and low charge injection, allowing them to be used in high precision measurement applications. A low supply current of 8nA and small package options enable use in portable applications.

### Device Information<sup>(1)</sup>

PART NUMBER	PACKAGE	BODY SIZE (NOM)
TMUX1109	TSSOP (16)	5.00 mm x 4.40 mm
	QFN (16)	2.60 mm x 1.80 mm

(1) For all available packages, see the package option addendum at the end of the data sheet.

### Application Example

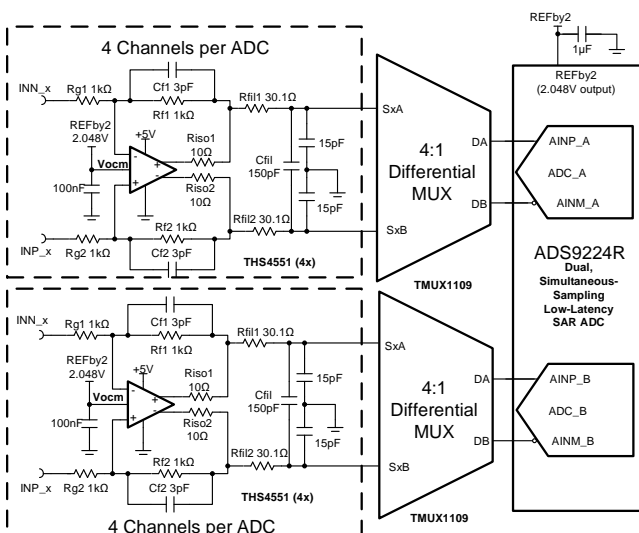

### Block Diagram

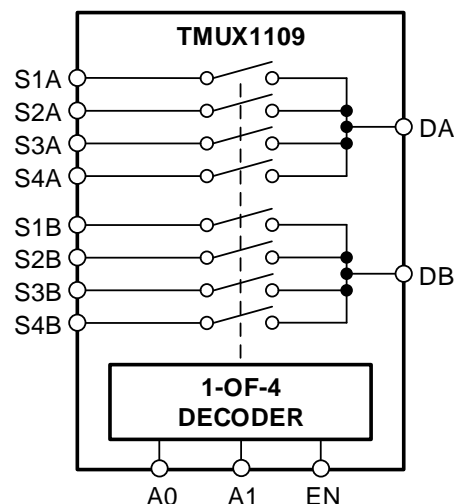

## Table of Contents

<b>1 Features</b> .....	<b>1</b>	7.4 Device Functional Modes.....	<b>25</b>
<b>2 Applications</b> .....	<b>1</b>	<b>8 Application and Implementation</b> .....	<b>26</b>
<b>3 Description</b> .....	<b>1</b>	8.1 Application Information.....	<b>26</b>
<b>4 Revision History</b> .....	<b>2</b>	8.2 Typical Application .....	<b>26</b>
<b>5 Pin Configuration and Functions</b> .....	<b>3</b>	8.3 Design Requirements.....	<b>27</b>
<b>6 Specifications</b> .....	<b>4</b>	8.4 Detailed Design Procedure .....	<b>27</b>
6.1 Absolute Maximum Ratings .....	<b>4</b>	8.5 Application Curve .....	<b>28</b>
6.2 ESD Ratings.....	<b>4</b>	<b>9 Power Supply Recommendations</b> .....	<b>28</b>
6.3 Recommended Operating Conditions.....	<b>4</b>	<b>10 Layout</b> .....	<b>29</b>
6.4 Thermal Information .....	<b>4</b>	10.1 Layout Guidelines .....	<b>29</b>
6.5 Electrical Characteristics ( $V_{DD} = 5\text{ V} \pm 10\%$ ) .....	<b>5</b>	10.2 Layout Example .....	<b>29</b>
6.6 Electrical Characteristics ( $V_{DD} = 3.3\text{ V} \pm 10\%$ ) .....	<b>7</b>	<b>11 Device and Documentation Support</b> .....	<b>30</b>
6.7 Electrical Characteristics ( $V_{DD} = 2.5\text{ V} \pm 10\%$ ), ( $V_{SS} = -2.5\text{ V} \pm 10\%$ ) .....	<b>9</b>	11.1 Documentation Support .....	<b>30</b>
6.8 Electrical Characteristics ( $V_{DD} = 1.8\text{ V} \pm 10\%$ ) .....	<b>11</b>	11.2 Related Links .....	<b>30</b>
6.9 Electrical Characteristics ( $V_{DD} = 1.2\text{ V} \pm 10\%$ ) .....	<b>13</b>	11.3 Receiving Notification of Documentation Updates .....	<b>30</b>
6.10 Typical Characteristics .....	<b>15</b>	11.4 Community Resources.....	<b>30</b>
<b>7 Detailed Description</b> .....	<b>18</b>	11.5 Trademarks .....	<b>30</b>
7.1 Overview .....	<b>18</b>	11.6 Electrostatic Discharge Caution.....	<b>30</b>
7.2 Functional Block Diagram .....	<b>23</b>	11.7 Glossary .....	<b>30</b>
7.3 Feature Description.....	<b>23</b>	<b>12 Mechanical, Packaging, and Orderable Information</b> .....	<b>30</b>

## 4 Revision History

NOTE: Page numbers for previous revisions may differ from page numbers in the current version.

DATE	REVISION	NOTES
December 2018	*	Initial release.

## 5 Pin Configuration and Functions

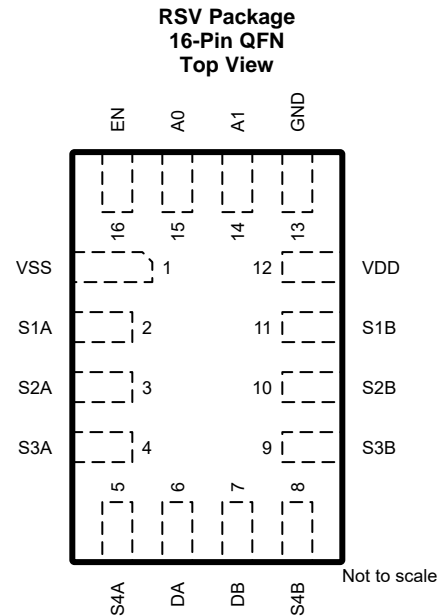
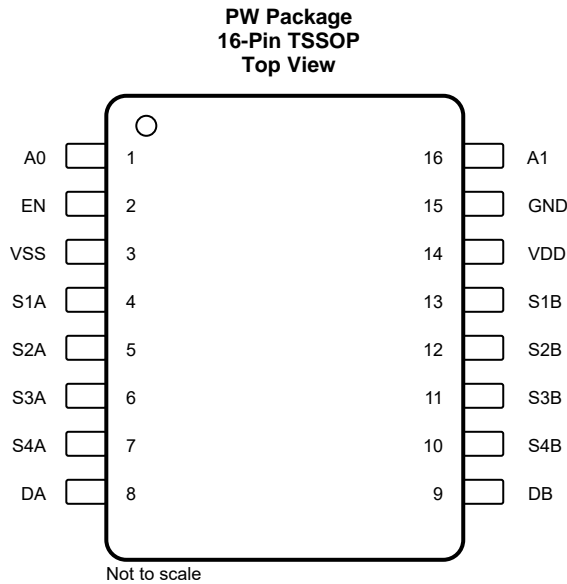

### Pin Functions

NAME	PIN		TYPE <sup>(1)</sup>	DESCRIPTION
	TSSOP	UQFN		
A0	1	15	I	Address line 0. Controls the switch configuration as shown in <a href="#">Table 1</a> .
EN	2	16	I	Active high logic input. When this pin is low, all switches are turned off. When this pin is high, the A[1:0] address inputs determine which switch is turned on.
VSS	3	1	P	Negative power supply. This pin is the most negative power-supply potential. For reliable operation, connect a decoupling capacitor ranging from 0.1 $\mu$ F to 10 $\mu$ F between $V_{SS}$ and GND. $V_{SS}$ can be connected to ground for single supply applications.
S1A	4	2	I/O	Source pin 1A. Can be an input or output.
S2A	5	3	I/O	Source pin 2A. Can be an input or output.
S3A	6	4	I/O	Source pin 3A. Can be an input or output.
S4A	7	5	I/O	Source pin 4A. Can be an input or output.
DA	8	6	I/O	Drain pin A. Can be an input or output.
DB	9	7	I/O	Drain pin B. Can be an input or output.
S4B	10	8	I/O	Source pin 4B. Can be an input or output.
S3B	11	9	I/O	Source pin 3B. Can be an input or output.
S2B	12	10	I/O	Source pin 2B. Can be an input or output.
S1B	13	11	I/O	Source pin 1B. Can be an input or output.
VDD	14	12	P	Positive power supply. This pin is the most positive power-supply potential. For reliable operation, connect a decoupling capacitor ranging from 0.1 $\mu$ F to 10 $\mu$ F between $V_{DD}$ and GND.
GND	15	13	P	Ground (0 V) reference
A1	16	14	I	Address line 1. Controls the switch configuration as shown in <a href="#">Table 1</a> .

(1) I = input, O = output, I/O = input and output, P = power

## 6 Specifications

### 6.1 Absolute Maximum Ratings

 over operating free-air temperature range (unless otherwise noted)<sup>(1)</sup> <sup>(2)</sup> <sup>(3)</sup>

		MIN	MAX	UNIT
$V_{DD}-V_{SS}$	Supply voltage	-0.5	6	V
$V_{DD}$		-0.5	6	V
$V_{SS}$		-3.0	0.3	V
$V_{SEL}$ or $V_{EN}$	Logic control input pin voltage (EN, A0, A1)	-0.5	6	V
$I_{SEL}$ or $I_{EN}$	Logic control input pin current (EN, A0, A1)	-30	30	mA
$V_S$ or $V_D$	Source or drain voltage (Sx, Dx)	-0.5	$V_{DD}+0.5$	V
$I_S$ or $I_D$ (CONT)	Source or drain continuous current (Sx, Dx)	-30	30	mA
$T_{stg}$	Storage temperature	-65	150	°C
$T_J$	Junction temperature		150	°C

- (1) Stresses beyond those listed under *Absolute Maximum Rating* may cause permanent damage to the device. These are stress ratings only, which do not imply functional operation of the device at these or any other conditions beyond those indicated under *Recommended Operating Condition*. Exposure to absolute-maximum-rated conditions for extended periods may affect device reliability.
- (2) The algebraic convention, whereby the most negative value is a minimum and the most positive value is a maximum.
- (3) All voltages are with respect to ground, unless otherwise specified.

### 6.2 ESD Ratings

		VALUE	UNIT
$V_{(ESD)}$	Electrostatic discharge	Human body model (HBM), per ANSI/ESDA/JEDEC JS-001, all pins <sup>(1)</sup>	±2000
		Charged device model (CDM), per JEDEC specification JESD22-C101, all pins <sup>(2)</sup>	±750

- (1) JEDEC document JEP155 states that 500-V HBM allows safe manufacturing with a standard ESD control process.
- (2) JEDEC document JEP157 states that 250-V CDM allows safe manufacturing with a standard ESD control process.

### 6.3 Recommended Operating Conditions

over operating free-air temperature range (unless otherwise noted)

		MIN	NOM	MAX	UNIT
$V_{DD}$	Positive power supply voltage (single)	1.08		5.5	V
$V_{SS}$	Negative power supply voltage (dual)	-2.75		0	V
$V_{DD} - V_{SS}$	Supply rail voltage difference	1.08		5.5	V
$V_S$ or $V_D$	Signal path input/output voltage (source or drain pin) (Sx, Dx)	$V_{SS}$		$V_{DD}$	V
$V_{SEL}$ or $V_{EN}$	Logic control input pin voltage	0		5.5	V
$T_A$	Ambient temperature	-40		125	°C

### 6.4 Thermal Information

THERMAL METRIC <sup>(1)</sup>		TMUX1109		UNIT
		PW (TSSOP)	RSV (QFN)	
		16 PINS	16 PINS	
$R_{\theta JA}$	Junction-to-ambient thermal resistance	118.9	134.6	°C/W
$R_{\theta JC(top)}$	Junction-to-case (top) thermal resistance	49.3	74.3	°C/W
$R_{\theta JB}$	Junction-to-board thermal resistance	65.2	62.8	°C/W
$\Psi_{JT}$	Junction-to-top characterization parameter	7.6	4.3	°C/W
$\Psi_{JB}$	Junction-to-board characterization parameter	64.6	61.1	°C/W
$R_{\theta JC(bot)}$	Junction-to-case (bottom) thermal resistance	N/A	N/A	°C/W

- (1) For more information about traditional and new thermal metrics, see the [Semiconductor and IC Package Thermal Metrics](#) application report.

## 6.5 Electrical Characteristics ( $V_{DD} = 5\text{ V} \pm 10\%$ )

at  $T_A = 25^\circ\text{C}$ ,  $V_{DD} = 5\text{ V}$  (unless otherwise noted)

PARAMETER		TEST CONDITIONS	TA	MIN	TYP	MAX	UNIT
<b>ANALOG SWITCH</b>							
$R_{ON}$	On-resistance	$V_S = 0\text{ V to }V_{DD}$ $I_{SD} = 10\text{ mA}$ Refer to <a href="#">On-Resistance</a>	25°C	1.8		4	$\Omega$
			-40°C to +85°C			4.5	$\Omega$
			-40°C to +125°C			4.9	$\Omega$
$\Delta R_{ON}$	On-resistance matching between channels	$V_S = 0\text{ V to }V_{DD}$ $I_{SD} = 10\text{ mA}$ Refer to <a href="#">On-Resistance</a>	25°C	0.18			$\Omega$
			-40°C to +85°C			0.4	$\Omega$
			-40°C to +125°C			0.5	$\Omega$
$R_{ON}$ FLAT	On-resistance flatness	$V_S = 0\text{ V to }V_{DD}$ $I_{SD} = 10\text{ mA}$ Refer to <a href="#">On-Resistance</a>	25°C	0.85			$\Omega$
			-40°C to +85°C			1.6	$\Omega$
			-40°C to +125°C			1.6	$\Omega$
$I_{S(OFF)}$	Source off leakage current <sup>(1)</sup>	$V_{DD} = 5\text{ V}$ Switch Off $V_D = 4.5\text{ V} / 1.5\text{ V}$ $V_S = 1.5\text{ V} / 4.5\text{ V}$ Refer to <a href="#">Off-Leakage Current</a>	25°C	-0.08	$\pm 0.005$	0.08	nA
			-40°C to +85°C		-0.3	0.3	nA
			-40°C to +125°C		-0.9	0.9	nA
$I_{D(OFF)}$	Drain off leakage current <sup>(1)</sup>	$V_{DD} = 5\text{ V}$ Switch Off $V_D = 4.5\text{ V} / 1.5\text{ V}$ $V_S = 1.5\text{ V} / 4.5\text{ V}$ Refer to <a href="#">Off-Leakage Current</a>	25°C	-0.1	$\pm 0.01$	0.1	nA
			-40°C to +85°C		-0.75	0.75	nA
			-40°C to +125°C		-3.5	3.5	nA
$I_{D(ON)}$ $I_{S(ON)}$	Channel on leakage current	$V_{DD} = 5\text{ V}$ Switch On $V_D = V_S = 2.5\text{ V}$ Refer to <a href="#">On-Leakage Current</a>	25°C	-0.025	$\pm 0.003$	0.025	nA
			-40°C to +85°C		-0.3	0.3	nA
			-40°C to +125°C		-0.75	0.75	nA
$I_{D(ON)}$ $I_{S(ON)}$	Channel on leakage current	$V_{DD} = 5\text{ V}$ Switch On $V_D = V_S = 4.5\text{ V} / 1.5\text{ V}$ Refer to <a href="#">On-Leakage Current</a>	25°C	-0.1	$\pm 0.01$	0.1	nA
			-40°C to +85°C		-0.75	0.75	nA
			-40°C to +125°C		-3	3	nA
<b>LOGIC INPUTS (EN, A0, A1)</b>							
$V_{IH}$	Input logic high		-40°C to +125°C	1.49		5.5	V
$V_{IL}$	Input logic low		-40°C to +125°C	0		0.87	V
$I_{IH}$ $I_{IL}$	Input leakage current		25°C	$\pm 0.005$			$\mu\text{A}$
$I_{IH}$ $I_{IL}$	Input leakage current		-40°C to +125°C			$\pm 0.05$	$\mu\text{A}$
$C_{IN}$	Logic input capacitance		25°C		1		pF
			-40°C to +125°C			2	pF
<b>POWER SUPPLY</b>							
$I_{DD}$	$V_{DD}$ supply current	Logic inputs = 0 V or 5.5 V	25°C	0.008			$\mu\text{A}$
			-40°C to +125°C			1	$\mu\text{A}$

(1) When  $V_S$  is 4.5 V,  $V_D$  is 1.5 V, and vice versa.

**Electrical Characteristics ( $V_{DD} = 5\text{ V} \pm 10\%$ ) (continued)**

 at  $T_A = 25^\circ\text{C}$ ,  $V_{DD} = 5\text{ V}$  (unless otherwise noted)

PARAMETER		TEST CONDITIONS	TA	MIN	TYP	MAX	UNIT
<b>DYNAMIC CHARACTERISTICS</b>							
$t_{\text{TRAN}}$	Transition time between channels	$V_S = 3\text{ V}$ $R_L = 200\ \Omega$ , $C_L = 15\text{ pF}$ Refer to <a href="#">Transition Time</a>	25°C	14			ns
			-40°C to +85°C			18	ns
			-40°C to +125°C			19	ns
$t_{\text{OPEN}}$ (BBM)	Break before make time	$V_S = 3\text{ V}$ $R_L = 200\ \Omega$ , $C_L = 15\text{ pF}$ Refer to <a href="#">Break-Before-Make</a>	25°C	8			ns
			-40°C to +85°C	1			ns
			-40°C to +125°C	1			ns
$t_{\text{ON(EN)}}$	Enable turn-on time	$V_S = 3\text{ V}$ $R_L = 200\ \Omega$ , $C_L = 15\text{ pF}$ Refer to $t_{\text{ON(EN)}}$ and $t_{\text{OFF(EN)}}$	25°C	12			ns
			-40°C to +85°C			19	ns
			-40°C to +125°C			20	ns
$t_{\text{OFF(EN)}}$	Enable turn-off time	$V_S = 3\text{ V}$ $R_L = 200\ \Omega$ , $C_L = 15\text{ pF}$ Refer to $t_{\text{ON(EN)}}$ and $t_{\text{OFF(EN)}}$	25°C	6			ns
			-40°C to +85°C			8	ns
			-40°C to +125°C			9	ns
$Q_C$	Charge Injection	$V_S = 1\text{ V}$ $R_S = 0\ \Omega$ , $C_L = 1\text{ nF}$ Refer to <a href="#">Charge Injection</a>	25°C		-1		pC
$O_{\text{ISO}}$	Off Isolation	$R_L = 50\ \Omega$ , $C_L = 5\text{ pF}$ $f = 1\text{ MHz}$ Refer to <a href="#">Off Isolation</a>	25°C		-65		dB
		$R_L = 50\ \Omega$ , $C_L = 5\text{ pF}$ $f = 10\text{ MHz}$ Refer to <a href="#">Off Isolation</a>	25°C		-45		dB
$X_{\text{TALK}}$	Crosstalk	$R_L = 50\ \Omega$ , $C_L = 5\text{ pF}$ $f = 1\text{ MHz}$ Refer to <a href="#">Crosstalk</a>	25°C		-90		dB
		$R_L = 50\ \Omega$ , $C_L = 5\text{ pF}$ $f = 10\text{ MHz}$ Refer to <a href="#">Crosstalk</a>	25°C		-80		dB
BW	Bandwidth	$R_L = 50\ \Omega$ , $C_L = 5\text{ pF}$ Refer to <a href="#">Bandwidth</a>	25°C		135		MHz
$C_{\text{SOFF}}$	Source off capacitance	$f = 1\text{ MHz}$	25°C		7.5		pF
$C_{\text{DOFF}}$	Drain off capacitance	$f = 1\text{ MHz}$	25°C		32		pF
$C_{\text{SON}}$ $C_{\text{DON}}$	On capacitance	$f = 1\text{ MHz}$	25°C		38		pF

## 6.6 Electrical Characteristics ( $V_{DD} = 3.3\text{ V} \pm 10\%$ )

at  $T_A = 25^\circ\text{C}$ ,  $V_{DD} = 3.3\text{ V}$  (unless otherwise noted)

PARAMETER		TEST CONDITIONS	TA	MIN	TYP	MAX	UNIT	
<b>ANALOG SWITCH</b>								
$R_{ON}$	On-resistance	$V_S = 0\text{ V to }V_{DD}$ $I_{SD} = 10\text{ mA}$ Refer to <a href="#">On-Resistance</a>	25°C		4	8.75	$\Omega$	
			-40°C to +85°C			9.5	$\Omega$	
			-40°C to +125°C			9.75	$\Omega$	
$\Delta R_{ON}$	On-resistance matching between channels	$V_S = 0\text{ V to }V_{DD}$ $I_{SD} = 10\text{ mA}$ Refer to <a href="#">On-Resistance</a>	25°C		0.13		$\Omega$	
			-40°C to +85°C			0.4	$\Omega$	
			-40°C to +125°C			0.5	$\Omega$	
$R_{ON\ FLAT}$	On-resistance flatness	$V_S = 0\text{ V to }V_{DD}$ $I_{SD} = 10\text{ mA}$ Refer to <a href="#">On-Resistance</a>	25°C		1.9		$\Omega$	
			-40°C to +85°C			2	$\Omega$	
			-40°C to +125°C			2.2	$\Omega$	
$I_{S(OFF)}$	Source off leakage current <sup>(1)</sup>	$V_{DD} = 3.3\text{ V}$ Switch Off $V_D = 3\text{ V} / 1\text{ V}$ $V_S = 1\text{ V} / 3\text{ V}$ Refer to <a href="#">Off-Leakage Current</a>	25°C	-0.05	$\pm 0.001$	0.05	nA	
			-40°C to +85°C		-0.1		0.1	nA
			-40°C to +125°C		-0.5		0.5	nA
$I_{D(OFF)}$	Drain off leakage current <sup>(1)</sup>	$V_{DD} = 3.3\text{ V}$ Switch Off $V_D = 3\text{ V} / 1\text{ V}$ $V_S = 1\text{ V} / 3\text{ V}$ Refer to <a href="#">Off-Leakage Current</a>	25°C	-0.1	$\pm 0.005$	0.1	nA	
			-40°C to +85°C		-0.5		0.5	nA
			-40°C to +125°C		-2		2	nA
$I_{D(ON)}$ $I_{S(ON)}$	Channel on leakage current	$V_{DD} = 3.3\text{ V}$ Switch On $V_D = V_S = 3\text{ V} / 1\text{ V}$ Refer to <a href="#">On-Leakage Current</a>	25°C	-0.1	$\pm 0.005$	0.1	nA	
			-40°C to +85°C		-0.5		0.5	nA
			-40°C to +125°C		-2		2	nA
<b>LOGIC INPUTS (EN, A0, A1)</b>								
$V_{IH}$	Input logic high		-40°C to +125°C	1.35		5.5	V	
$V_{IL}$	Input logic low						0	0.8
$I_{IH}$ $I_{IL}$	Input leakage current		25°C		$\pm 0.005$		$\mu\text{A}$	
$I_{IH}$ $I_{IL}$	Input leakage current		-40°C to +125°C			$\pm 0.05$	$\mu\text{A}$	
$C_{IN}$	Logic input capacitance		25°C		1		pF	
			-40°C to +125°C			2	pF	
<b>POWER SUPPLY</b>								
$I_{DD}$	$V_{DD}$ supply current	Logic inputs = 0 V or 5.5 V	25°C		0.006		$\mu\text{A}$	
			-40°C to +125°C			1	$\mu\text{A}$	

(1) When  $V_S$  is 3 V,  $V_D$  is 1 V, and vice versa.

**Electrical Characteristics ( $V_{DD} = 3.3\text{ V} \pm 10\%$ ) (continued)**

 at  $T_A = 25^\circ\text{C}$ ,  $V_{DD} = 3.3\text{ V}$  (unless otherwise noted)

PARAMETER		TEST CONDITIONS	TA	MIN	TYP	MAX	UNIT
<b>DYNAMIC CHARACTERISTICS</b>							
$t_{\text{TRAN}}$	Transition time between channels	$V_S = 2\text{ V}$ $R_L = 200\ \Omega$ , $C_L = 15\text{ pF}$ Refer to <a href="#">Transition Time</a>	25°C	15			ns
			–40°C to +85°C			23	ns
			–40°C to +125°C			23	ns
$t_{\text{OPEN}}$ (BBM)	Break before make time	$V_S = 2\text{ V}$ $R_L = 200\ \Omega$ , $C_L = 15\text{ pF}$ Refer to <a href="#">Break-Before-Make</a>	25°C	9			ns
			–40°C to +85°C	1			ns
			–40°C to +125°C	1			ns
$t_{\text{ON(EN)}}$	Enable turn-on time	$V_S = 2\text{ V}$ $R_L = 200\ \Omega$ , $C_L = 15\text{ pF}$ Refer to $t_{\text{ON(EN)}}$ and $t_{\text{OFF(EN)}}$	25°C	14			ns
			–40°C to +85°C			25	ns
			–40°C to +125°C			25	ns
$t_{\text{OFF(EN)}}$	Enable turn-off time	$V_S = 2\text{ V}$ $R_L = 200\ \Omega$ , $C_L = 15\text{ pF}$ Refer to $t_{\text{ON(EN)}}$ and $t_{\text{OFF(EN)}}$	25°C	7			ns
			–40°C to +85°C			12	ns
			–40°C to +125°C			12	ns
$Q_C$	Charge Injection	$V_S = 1\text{ V}$ $R_S = 0\ \Omega$ , $C_L = 1\text{ nF}$ Refer to <a href="#">Charge Injection</a>	25°C		–1		pC
$O_{\text{ISO}}$	Off Isolation	$R_L = 50\ \Omega$ , $C_L = 5\text{ pF}$ $f = 1\text{ MHz}$ Refer to <a href="#">Off Isolation</a>	25°C		–65		dB
		$R_L = 50\ \Omega$ , $C_L = 5\text{ pF}$ $f = 10\text{ MHz}$ Refer to <a href="#">Off Isolation</a>	25°C		–45		dB
$X_{\text{TALK}}$	Crosstalk	$R_L = 50\ \Omega$ , $C_L = 5\text{ pF}$ $f = 1\text{ MHz}$ Refer to <a href="#">Crosstalk</a>	25°C		–90		dB
		$R_L = 50\ \Omega$ , $C_L = 5\text{ pF}$ $f = 10\text{ MHz}$ Refer to <a href="#">Crosstalk</a>	25°C		–80		dB
BW	Bandwidth	$R_L = 50\ \Omega$ , $C_L = 5\text{ pF}$ Refer to <a href="#">Bandwidth</a>	25°C		135		MHz
$C_{\text{SOFF}}$	Source off capacitance	$f = 1\text{ MHz}$	25°C		7		pF
$C_{\text{DOFF}}$	Drain off capacitance	$f = 1\text{ MHz}$	25°C		32		pF
$C_{\text{SON}}$ $C_{\text{DON}}$	On capacitance	$f = 1\text{ MHz}$	25°C		38		pF



## 6.7 Electrical Characteristics ( $V_{DD} = 2.5\text{ V} \pm 10\%$ ), ( $V_{SS} = -2.5\text{ V} \pm 10\%$ )

at  $T_A = 25^\circ\text{C}$ ,  $V_{DD} = +2.5\text{ V}$ ,  $V_{SS} = -2.5\text{ V}$  (unless otherwise noted)

PARAMETER		TEST CONDITIONS	TA	MIN	TYP	MAX	UNIT	
<b>ANALOG SWITCH</b>								
$R_{ON}$	On-resistance	$V_S = V_{SS}$ to $V_{DD}$ $I_{SD} = 10\text{ mA}$ Refer to <a href="#">On-Resistance</a>	25°C	1.8		4	$\Omega$	
			-40°C to +85°C			4.5	$\Omega$	
			-40°C to +125°C			4.9	$\Omega$	
$\Delta R_{ON}$	On-resistance matching between channels	$V_S = V_{SS}$ to $V_{DD}$ $I_{SD} = 10\text{ mA}$ Refer to <a href="#">On-Resistance</a>	25°C	0.18			$\Omega$	
			-40°C to +85°C			0.4	$\Omega$	
			-40°C to +125°C			0.5	$\Omega$	
$R_{ON}$ FLAT	On-resistance flatness	$V_S = V_{SS}$ to $V_{DD}$ $I_{SD} = 10\text{ mA}$ Refer to <a href="#">On-Resistance</a>	25°C	0.85			$\Omega$	
			-40°C to +85°C			1.6	$\Omega$	
			-40°C to +125°C			1.6	$\Omega$	
$I_{S(OFF)}$	Source off leakage current <sup>(1)</sup>	$V_{DD} = +2.5\text{ V}$ , $V_{SS} = -2.5\text{ V}$ Switch Off $V_D = +2\text{ V} / -1\text{ V}$ $V_S = -1\text{ V} / +2\text{ V}$ Refer to <a href="#">Off-Leakage Current</a>	25°C	-0.08	$\pm 0.005$	0.08	nA	
			-40°C to +85°C			-0.3	0.3	nA
			-40°C to +125°C			-0.9	0.9	nA
$I_{D(OFF)}$	Drain off leakage current <sup>(1)</sup>	$V_{DD} = +2.5\text{ V}$ , $V_{SS} = -2.5\text{ V}$ Switch Off $V_D = +2\text{ V} / -1\text{ V}$ $V_S = -1\text{ V} / +2\text{ V}$ Refer to <a href="#">Off-Leakage Current</a>	25°C	-0.1	$\pm 0.01$	0.1	nA	
			-40°C to +85°C			-0.75	0.75	nA
			-40°C to +125°C			-3.5	3.5	nA
$I_{D(ON)}$ $I_{S(ON)}$	Channel on leakage current	$V_{DD} = +2.5\text{ V}$ , $V_{SS} = -2.5\text{ V}$ Switch On $V_D = V_S = +2\text{ V} / -1\text{ V}$ Refer to <a href="#">On-Leakage Current</a>	25°C	-0.1	$\pm 0.01$	0.1	nA	
			-40°C to +85°C			-0.75	0.75	nA
			-40°C to +125°C			-3	3	nA
<b>LOGIC INPUTS (EN, A0, A1)</b>								
$V_{IH}$	Input logic high		-40°C to +125°C	1.2		2.75	V	
$V_{IL}$	Input logic low			0		0.73	V	
$I_{IH}$ $I_{IL}$	Input leakage current		25°C	$\pm 0.005$			$\mu\text{A}$	
$I_{IH}$ $I_{IL}$	Input leakage current		-40°C to +125°C			$\pm 0.05$	$\mu\text{A}$	
$C_{IN}$	Logic input capacitance		25°C		1		pF	
			-40°C to +125°C			2	pF	
<b>POWER SUPPLY</b>								
$I_{DD}$	$V_{DD}$ supply current	Logic inputs = 0 V or 2.75 V	25°C	0.008			$\mu\text{A}$	
			-40°C to +125°C			1	$\mu\text{A}$	
$I_{SS}$	$V_{SS}$ supply current	Logic inputs = 0 V or 2.75 V	25°C	0.008			$\mu\text{A}$	
			-40°C to +125°C			1	$\mu\text{A}$	

(1) When  $V_S$  is positive,  $V_D$  is negative, and vice versa.

**Electrical Characteristics ( $V_{DD} = 2.5\text{ V} \pm 10\%$ ), ( $V_{SS} = -2.5\text{ V} \pm 10\%$ ) (continued)**

 at  $T_A = 25^\circ\text{C}$ ,  $V_{DD} = +2.5\text{ V}$ ,  $V_{SS} = -2.5\text{ V}$  (unless otherwise noted)

PARAMETER		TEST CONDITIONS	TA	MIN	TYP	MAX	UNIT
<b>DYNAMIC CHARACTERISTICS</b>							
$t_{\text{TRAN}}$	Transition time between channels	$V_S = 1.5\text{ V}$ $R_L = 200\ \Omega$ , $C_L = 15\text{ pF}$ Refer to <a href="#">Transition Time</a>	25°C	14			ns
			-40°C to +85°C			21	ns
			-40°C to +125°C			21	ns
$t_{\text{OPEN}}$ (BBM)	Break before make time	$V_S = 1.5\text{ V}$ $R_L = 200\ \Omega$ , $C_L = 15\text{ pF}$ Refer to <a href="#">Break-Before-Make</a>	25°C	8			ns
			-40°C to +85°C	1			ns
			-40°C to +125°C	1			ns
$t_{\text{ON(EN)}}$	Enable turn-on time	$V_S = 1.5\text{ V}$ $R_L = 200\ \Omega$ , $C_L = 15\text{ pF}$ Refer to $t_{\text{ON(EN)}}$ and $t_{\text{OFF(EN)}}$	25°C	14			ns
			-40°C to +85°C			21	ns
			-40°C to +125°C			22	ns
$t_{\text{OFF(EN)}}$	Enable turn-off time	$V_S = 1.5\text{ V}$ $R_L = 200\ \Omega$ , $C_L = 15\text{ pF}$ Refer to $t_{\text{ON(EN)}}$ and $t_{\text{OFF(EN)}}$	25°C	8			ns
			-40°C to +85°C			11	ns
			-40°C to +125°C			12	ns
$Q_C$	Charge Injection	$V_S = -1\text{ V}$ $R_S = 0\ \Omega$ , $C_L = 1\text{ nF}$ Refer to <a href="#">Charge Injection</a>	25°C		-1		pC
$O_{\text{ISO}}$	Off Isolation	$R_L = 50\ \Omega$ , $C_L = 5\text{ pF}$ $f = 1\text{ MHz}$ Refer to <a href="#">Off Isolation</a>	25°C		-65		dB
		$R_L = 50\ \Omega$ , $C_L = 5\text{ pF}$ $f = 10\text{ MHz}$ Refer to <a href="#">Off Isolation</a>	25°C		-45		dB
$X_{\text{TALK}}$	Crosstalk	$R_L = 50\ \Omega$ , $C_L = 5\text{ pF}$ $f = 1\text{ MHz}$ Refer to <a href="#">Crosstalk</a>	25°C		-90		dB
		$R_L = 50\ \Omega$ , $C_L = 5\text{ pF}$ $f = 10\text{ MHz}$ Refer to <a href="#">Crosstalk</a>	25°C		-80		dB
BW	Bandwidth	$R_L = 50\ \Omega$ , $C_L = 5\text{ pF}$ Refer to <a href="#">Bandwidth</a>	25°C		135		MHz
$C_{\text{SOFF}}$	Source off capacitance	$f = 1\text{ MHz}$	25°C		7		pF
$C_{\text{DOFF}}$	Drain off capacitance	$f = 1\text{ MHz}$	25°C		32		pF
$C_{\text{SON}}$ $C_{\text{DON}}$	On capacitance	$f = 1\text{ MHz}$	25°C		38		pF

## 6.8 Electrical Characteristics ( $V_{DD} = 1.8\text{ V} \pm 10\%$ )

at  $T_A = 25^\circ\text{C}$ ,  $V_{DD} = 1.8\text{ V}$  (unless otherwise noted)

PARAMETER		TEST CONDITIONS	TA	MIN	TYP	MAX	UNIT	
<b>ANALOG SWITCH</b>								
$R_{ON}$	On-resistance	$V_S = 0\text{ V to }V_{DD}$ $I_{SD} = 10\text{ mA}$ Refer to <a href="#">On-Resistance</a>	25°C	40			$\Omega$	
			-40°C to +85°C			80	$\Omega$	
			-40°C to +125°C			80	$\Omega$	
$\Delta R_{ON}$	On-resistance matching between channels	$V_S = 0\text{ V to }V_{DD}$ $I_{SD} = 10\text{ mA}$ Refer to <a href="#">On-Resistance</a>	25°C	0.4			$\Omega$	
			-40°C to +85°C			1.5	$\Omega$	
			-40°C to +125°C			1.5	$\Omega$	
$I_{S(OFF)}$	Source off leakage current <sup>(1)</sup>	$V_{DD} = 1.98\text{ V}$ Switch Off $V_D = 1.62\text{ V} / 1\text{ V}$ $V_S = 1\text{ V} / 1.62\text{ V}$ Refer to <a href="#">Off-Leakage Current</a>	25°C	-0.05	$\pm 0.003$	0.05	nA	
			-40°C to +85°C		-0.1		0.1	nA
			-40°C to +125°C		-0.5		0.5	nA
$I_{D(OFF)}$	Drain off leakage current <sup>(1)</sup>	$V_{DD} = 1.98\text{ V}$ Switch Off $V_D = 1.62\text{ V} / 1\text{ V}$ $V_S = 1\text{ V} / 1.62\text{ V}$ Refer to <a href="#">Off-Leakage Current</a>	25°C	-0.1	$\pm 0.005$	0.1	nA	
			-40°C to +85°C		-0.5		0.5	nA
			-40°C to +125°C		-2		2	nA
$I_{D(ON)}$ $I_{S(ON)}$	Channel on leakage current	$V_{DD} = 1.98\text{ V}$ Switch On $V_D = V_S = 1.62\text{ V} / 1\text{ V}$ Refer to <a href="#">On-Leakage Current</a>	25°C	-0.1	$\pm 0.005$	0.1	nA	
			-40°C to +85°C		-0.5		0.5	nA
			-40°C to +125°C		-2		2	nA
<b>LOGIC INPUTS (EN, A0, A1)</b>								
$V_{IH}$	Input logic high		-40°C to +125°C	1.07		5.5	V	
$V_{IL}$	Input logic low			0		0.68	V	
$I_{IH}$ $I_{IL}$	Input leakage current		25°C	$\pm 0.005$			$\mu\text{A}$	
			-40°C to +125°C		$\pm 0.05$		$\mu\text{A}$	
$C_{IN}$	Logic input capacitance		25°C	1			pF	
			-40°C to +125°C		2		pF	
<b>POWER SUPPLY</b>								
$I_{DD}$	$V_{DD}$ supply current	Logic inputs = 0 V or 5.5 V	25°C	0.001			$\mu\text{A}$	
			-40°C to +125°C		0.85		$\mu\text{A}$	

(1) When  $V_S$  is 1.62 V,  $V_D$  is 1 V, and vice versa.

**Electrical Characteristics ( $V_{DD} = 1.8\text{ V} \pm 10\%$ ) (continued)**

 at  $T_A = 25^\circ\text{C}$ ,  $V_{DD} = 1.8\text{ V}$  (unless otherwise noted)

PARAMETER		TEST CONDITIONS	TA	MIN	TYP	MAX	UNIT
<b>DYNAMIC CHARACTERISTICS</b>							
$t_{\text{TRAN}}$	Transition time between channels	$V_S = 1\text{ V}$ $R_L = 200\ \Omega$ , $C_L = 15\text{ pF}$ Refer to <a href="#">Transition Time</a>	25°C		28		ns
			–40°C to +85°C			48	ns
			–40°C to +125°C			48	ns
$t_{\text{OPEN}}$ (BBM)	Break before make time	$V_S = 1\text{ V}$ $R_L = 200\ \Omega$ , $C_L = 15\text{ pF}$ Refer to <a href="#">Break-Before-Make</a>	25°C		16		ns
			–40°C to +85°C		1		ns
			–40°C to +125°C		1		ns
$t_{\text{ON(EN)}}$	Enable turn-on time	$V_S = 1\text{ V}$ $R_L = 200\ \Omega$ , $C_L = 15\text{ pF}$ Refer to $t_{\text{ON(EN)}}$ and $t_{\text{OFF(EN)}}$	25°C		28		ns
			–40°C to +85°C			48	ns
			–40°C to +125°C			48	ns
$t_{\text{OFF(EN)}}$	Enable turn-off time	$V_S = 1\text{ V}$ $R_L = 200\ \Omega$ , $C_L = 15\text{ pF}$ Refer to $t_{\text{ON(EN)}}$ and $t_{\text{OFF(EN)}}$	25°C		16		ns
			–40°C to +85°C			27	ns
			–40°C to +125°C			27	ns
$Q_C$	Charge Injection	$V_S = 1\text{ V}$ $R_S = 0\ \Omega$ , $C_L = 1\text{ nF}$ Refer to <a href="#">Charge Injection</a>	25°C		–0.5		pC
$O_{\text{ISO}}$	Off Isolation	$R_L = 50\ \Omega$ , $C_L = 5\text{ pF}$ $f = 1\text{ MHz}$ Refer to <a href="#">Off Isolation</a>	25°C		–65		dB
		$R_L = 50\ \Omega$ , $C_L = 5\text{ pF}$ $f = 10\text{ MHz}$ Refer to <a href="#">Off Isolation</a>	25°C		–45		dB
$X_{\text{TALK}}$	Crosstalk	$R_L = 50\ \Omega$ , $C_L = 5\text{ pF}$ $f = 1\text{ MHz}$ Refer to <a href="#">Crosstalk</a>	25°C		–90		dB
		$R_L = 50\ \Omega$ , $C_L = 5\text{ pF}$ $f = 10\text{ MHz}$ Refer to <a href="#">Crosstalk</a>	25°C		–80		dB
BW	Bandwidth	$R_L = 50\ \Omega$ , $C_L = 5\text{ pF}$ Refer to <a href="#">Bandwidth</a>	25°C		135		MHz
$C_{\text{SOFF}}$	Source off capacitance	$f = 1\text{ MHz}$	25°C		7		pF
$C_{\text{DOFF}}$	Drain off capacitance	$f = 1\text{ MHz}$	25°C		32		pF
$C_{\text{SON}}$ $C_{\text{DON}}$	On capacitance	$f = 1\text{ MHz}$	25°C		38		pF

**6.9 Electrical Characteristics ( $V_{DD} = 1.2\text{ V} \pm 10\%$ )**

PARAMETER		TEST CONDITIONS	TA	MIN	TYP	MAX	UNIT
<b>ANALOG SWITCH</b>							
$R_{ON}$	On-resistance	$V_S = 0\text{ V to }V_{DD}$ $I_{SD} = 10\text{ mA}$ Refer to <a href="#">On-Resistance</a>	25°C	70			$\Omega$
			-40°C to +85°C			105	$\Omega$
			-40°C to +125°C			105	$\Omega$
$\Delta R_{ON}$	On-resistance matching between channels	$V_S = 0\text{ V to }V_{DD}$ $I_{SD} = 10\text{ mA}$ Refer to <a href="#">On-Resistance</a>	25°C	0.4			$\Omega$
			-40°C to +85°C			1.5	$\Omega$
			-40°C to +125°C			1.5	$\Omega$
$I_{S(OFF)}$	Source off leakage current <sup>(1)</sup>	$V_{DD} = 1.32\text{ V}$ Switch Off $V_D = 1\text{ V} / 0.8\text{ V}$ $V_S = 0.8\text{ V} / 1\text{ V}$ Refer to <a href="#">Off-Leakage Current</a>	25°C	-0.05	$\pm 0.003$	0.05	nA
			-40°C to +85°C	-0.1		0.1	nA
			-40°C to +125°C	-0.5		0.5	nA
$I_{D(OFF)}$	Drain off leakage current <sup>(1)</sup>	$V_{DD} = 1.32\text{ V}$ Switch Off $V_D = 1\text{ V} / 0.8\text{ V}$ $V_S = 0.8\text{ V} / 1\text{ V}$ Refer to <a href="#">Off-Leakage Current</a>	25°C	-0.1	$\pm 0.005$	0.1	nA
			-40°C to +85°C	-0.5		0.5	nA
			-40°C to +125°C	-2		2	nA
$I_{D(ON)}$ $I_{S(ON)}$	Channel on leakage current	$V_{DD} = 1.32\text{ V}$ Switch On $V_D = V_S = 1\text{ V} / 0.8\text{ V}$ Refer to <a href="#">On-Leakage Current</a>	25°C	-0.1	$\pm 0.005$	0.1	nA
			-40°C to +85°C	-0.5		0.5	nA
			-40°C to +125°C	-2		2	nA
<b>LOGIC INPUTS (EN, A0, A1)</b>							
$V_{IH}$	Input logic high		-40°C to +125°C	0.96		5.5	V
$V_{IL}$	Input logic low			0		0.36	V
$I_{IH}$ $I_{IL}$	Input leakage current		25°C	$\pm 0.005$			$\mu\text{A}$
			-40°C to +125°C			$\pm 0.05$	$\mu\text{A}$
$C_{IN}$	Logic input capacitance		25°C	1			pF
			-40°C to +125°C			2	pF
<b>POWER SUPPLY</b>							
$I_{DD}$	$V_{DD}$ supply current	Logic inputs = 0 V or 5.5 V	25°C	0.001			$\mu\text{A}$
			-40°C to +125°C			0.7	$\mu\text{A}$

(1) When  $V_S$  is 1 V,  $V_D$  is 0.8 V, and vice versa.

**Electrical Characteristics ( $V_{DD} = 1.2\text{ V} \pm 10\%$ ) (continued)**

PARAMETER		TEST CONDITIONS	TA	MIN	TYP	MAX	UNIT
<b>DYNAMIC CHARACTERISTICS</b>							
$t_{\text{TRAN}}$	Transition time between channels	$V_S = 1\text{ V}$ $R_L = 200\ \Omega$ , $C_L = 15\text{ pF}$ Refer to <a href="#">Transition Time</a>	25°C		60		ns
			–40°C to +85°C			210	ns
			–40°C to +125°C			210	ns
$t_{\text{OPEN}}$ (BBM)	Break before make time	$V_S = 1\text{ V}$ $R_L = 200\ \Omega$ , $C_L = 15\text{ pF}$ Refer to <a href="#">Break-Before-Make</a>	25°C		28		ns
			–40°C to +85°C		1		ns
			–40°C to +125°C		1		ns
$t_{\text{ON(EN)}}$	Enable turn-on time	$V_S = 1\text{ V}$ $R_L = 200\ \Omega$ , $C_L = 15\text{ pF}$ Refer to $t_{\text{ON(EN)}}$ and $t_{\text{OFF(EN)}}$	25°C		60		ns
			–40°C to +85°C			190	ns
			–40°C to +125°C			190	ns
$t_{\text{OFF(EN)}}$	Enable turn-off time	$V_S = 1\text{ V}$ $R_L = 200\ \Omega$ , $C_L = 15\text{ pF}$ Refer to $t_{\text{ON(EN)}}$ and $t_{\text{OFF(EN)}}$	25°C		45		ns
			–40°C to +85°C			150	ns
			–40°C to +125°C			150	ns
$Q_C$	Charge Injection	$V_S = 1\text{ V}$ $R_S = 0\ \Omega$ , $C_L = 1\text{ nF}$ Refer to <a href="#">Charge Injection</a>	25°C		–0.5		pC
$O_{\text{ISO}}$	Off Isolation	$R_L = 50\ \Omega$ , $C_L = 5\text{ pF}$ $f = 1\text{ MHz}$ Refer to <a href="#">Off Isolation</a>	25°C		–65		dB
		$R_L = 50\ \Omega$ , $C_L = 5\text{ pF}$ $f = 10\text{ MHz}$ Refer to <a href="#">Off Isolation</a>	25°C		–45		dB
$X_{\text{TALK}}$	Crosstalk	$R_L = 50\ \Omega$ , $C_L = 5\text{ pF}$ $f = 1\text{ MHz}$ Refer to <a href="#">Crosstalk</a>	25°C		–90		dB
		$R_L = 50\ \Omega$ , $C_L = 5\text{ pF}$ $f = 10\text{ MHz}$ Refer to <a href="#">Crosstalk</a>	25°C		–80		dB
BW	Bandwidth	$R_L = 50\ \Omega$ , $C_L = 5\text{ pF}$ Refer to <a href="#">Bandwidth</a>	25°C		135		MHz
$C_{\text{SOFF}}$	Source off capacitance	$f = 1\text{ MHz}$	25°C		7		pF
$C_{\text{DOFF}}$	Drain off capacitance	$f = 1\text{ MHz}$	25°C		32		pF
$C_{\text{SON}}$ $C_{\text{DON}}$	On capacitance	$f = 1\text{ MHz}$	25°C		38		pF

### 6.10 Typical Characteristics

at  $T_A = 25^\circ\text{C}$ ,  $V_{DD} = 5\text{ V}$  (unless otherwise noted)

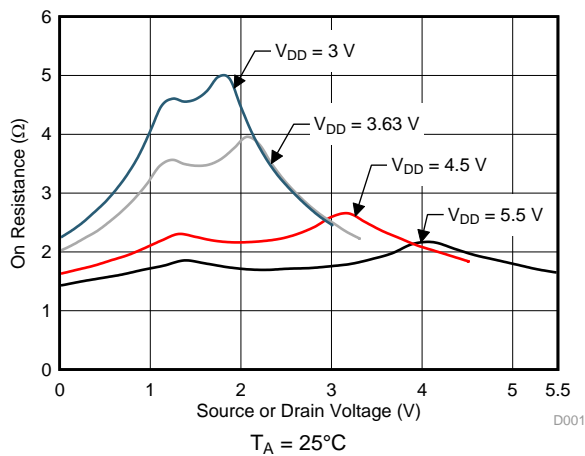

Figure 1. On-Resistance vs Source or Drain Voltage

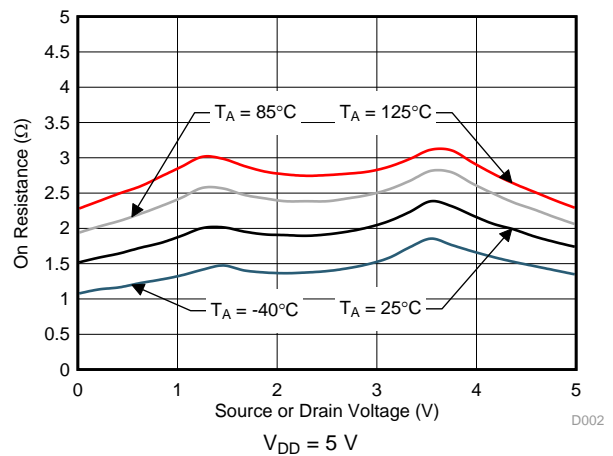

Figure 2. On-Resistance vs Temperature

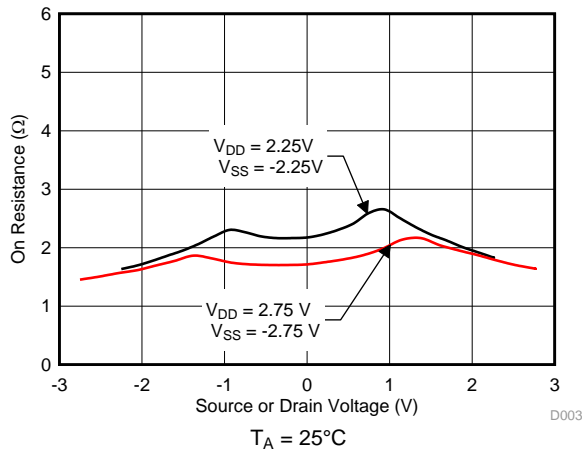

Figure 3. On-Resistance vs Source or Drain Voltage

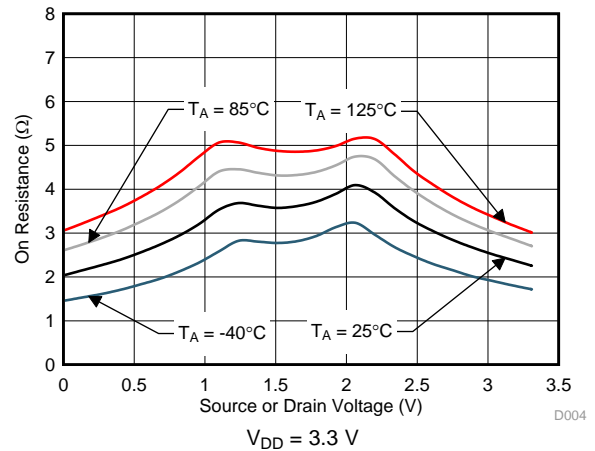

Figure 4. On-Resistance vs Temperature

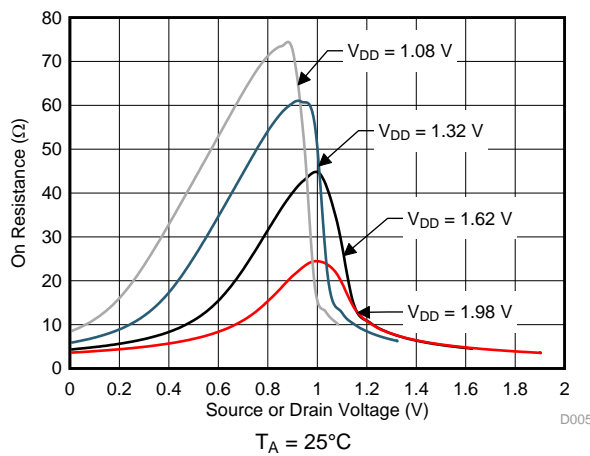

Figure 5. On-Resistance vs Source or Drain Voltage

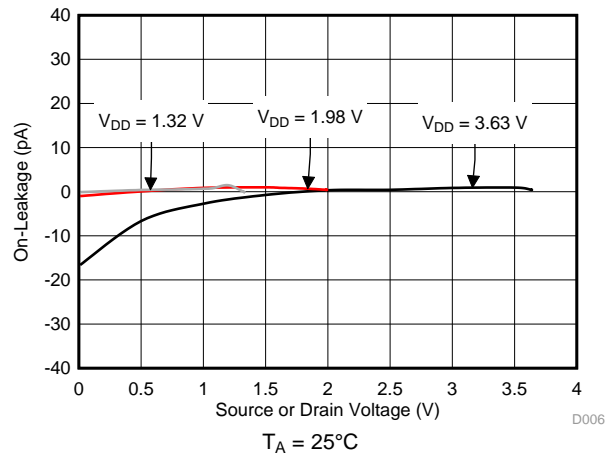

Figure 6. On-Leakage vs Source or Drain Voltage

Typical Characteristics (continued)

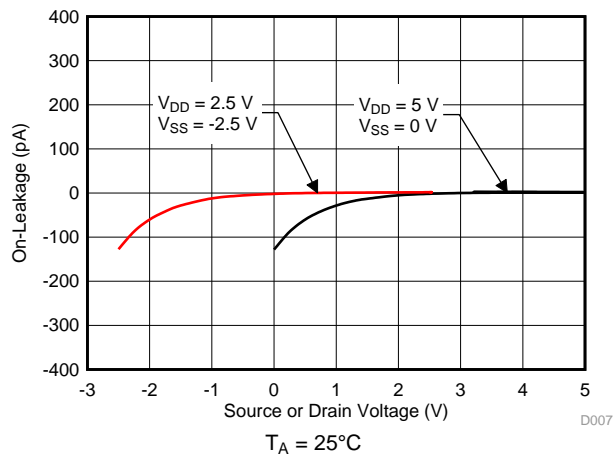

Figure 7. On-Leakage vs Source or Drain Voltage

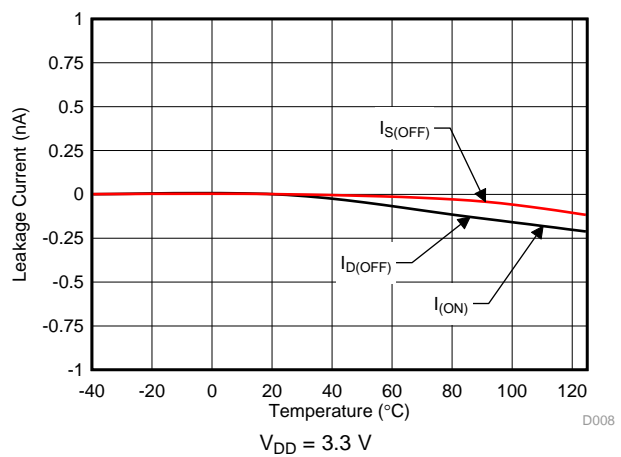

Figure 8. Leakage Current vs Temperature

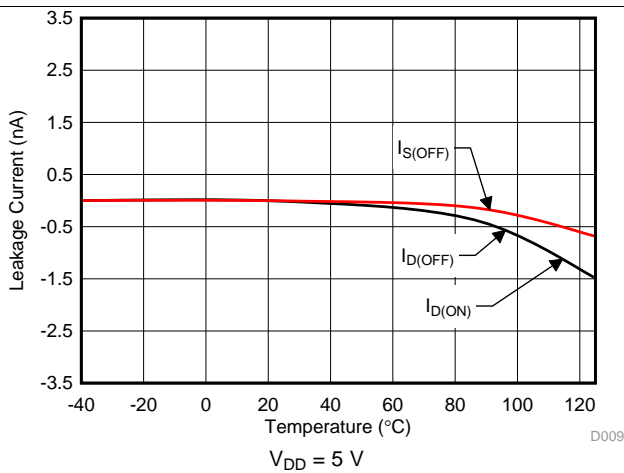

Figure 9. Leakage Current vs Temperature

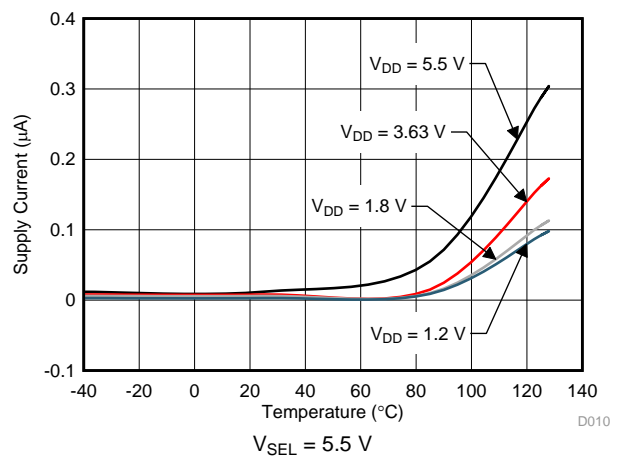

Figure 10. Supply Current vs Temperature

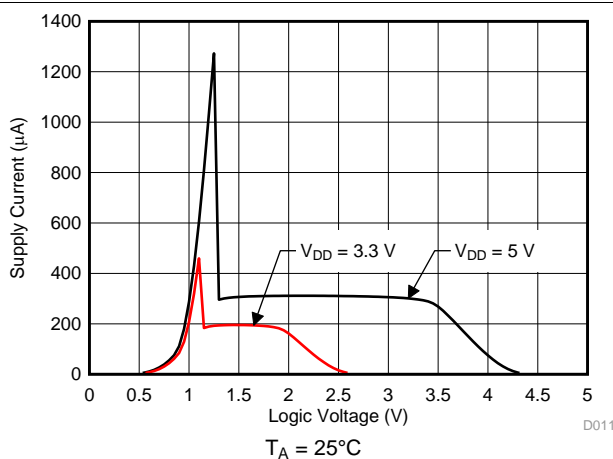

Figure 11. Supply Current vs Logic Voltage

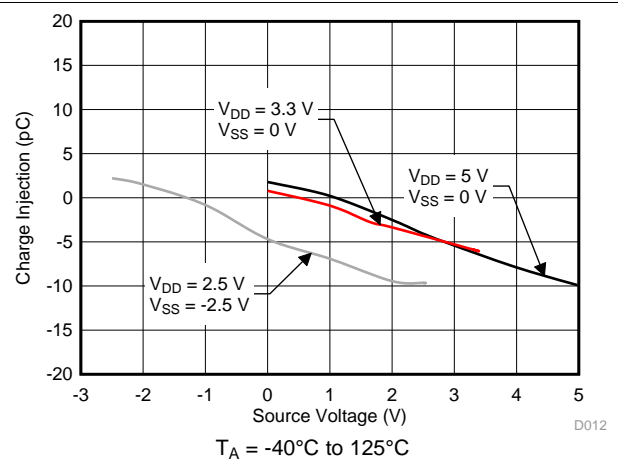

Figure 12. Charge Injection vs Source or Drain Voltage



Typical Characteristics (continued)

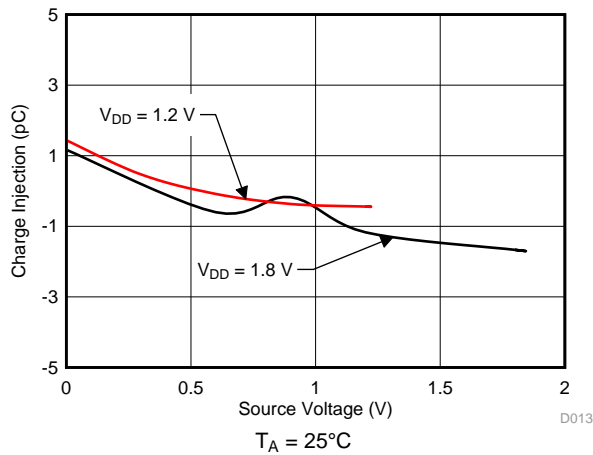

Figure 13. Charge Injection vs Source or Drain Voltage

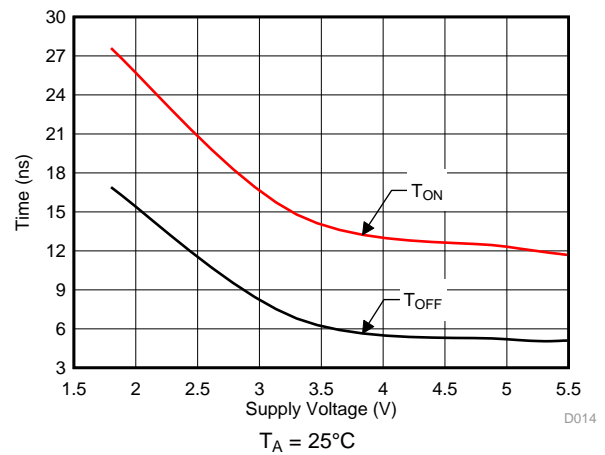

Figure 14.  $T_{ON(EN)}$  and  $T_{OFF(EN)}$  vs Supply Voltage

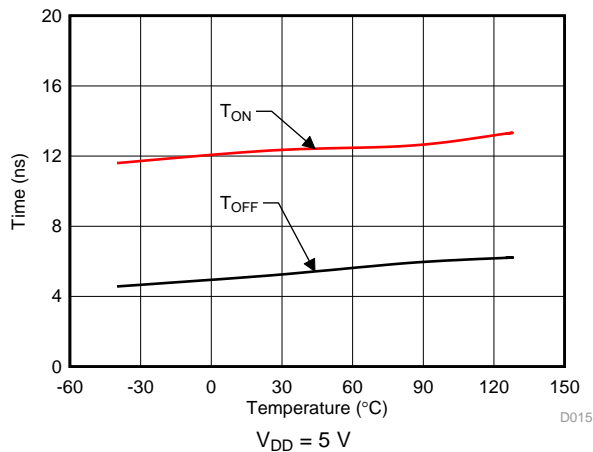

Figure 15.  $T_{ON(EN)}$  and  $T_{OFF(EN)}$  vs Temperature

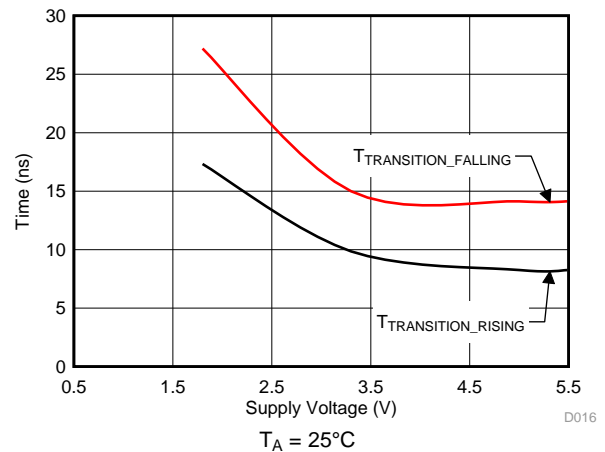

Figure 16.  $T_{TRANSITION}$  vs Supply Voltage

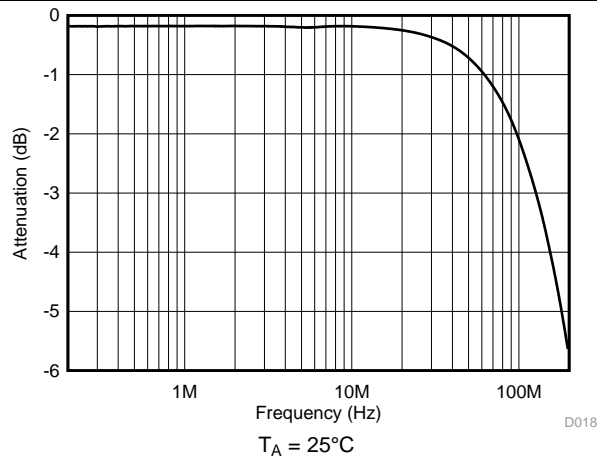

Figure 17. Frequency Response

## 7 Detailed Description

### 7.1 Overview

#### 7.1.1 On-Resistance

The on-resistance of a device is the ohmic resistance between the source (Sx) and drain (D) pins of the device. The on-resistance varies with input voltage and supply voltage. The symbol  $R_{ON}$  is used to denote on-resistance. The measurement setup used to measure  $R_{ON}$  is shown in Figure 18. Voltage (V) and current ( $I_{SD}$ ) are measured using this setup, and  $R_{ON}$  is computed with  $R_{ON} = V / I_{SD}$ :

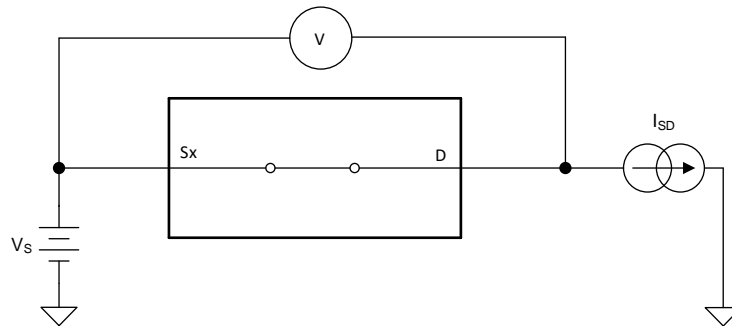

**Figure 18. On-Resistance Measurement Setup**

#### 7.1.2 Off-Leakage Current

There are two types of leakage currents associated with a switch during the off state:

1. Source off-leakage current
2. Drain off-leakage current

Source leakage current is defined as the leakage current flowing into or out of the source pin when the switch is off. This current is denoted by the symbol  $I_{S(OFF)}$ .

Drain leakage current is defined as the leakage current flowing into or out of the drain pin when the switch is off. This current is denoted by the symbol  $I_{D(OFF)}$ .

The setup used to measure both off-leakage currents is shown in Figure 19.

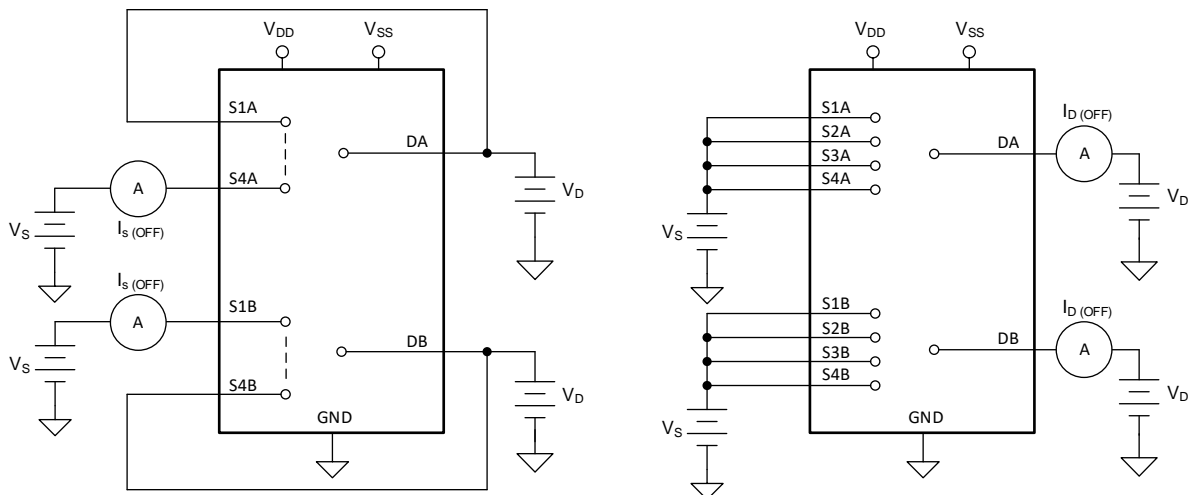

**Figure 19. Off-Leakage Measurement Setup**

## Overview (continued)

### 7.1.3 On-Leakage Current

Source on-leakage current is defined as the leakage current flowing into or out of the source pin when the switch is on. This current is denoted by the symbol  $I_{S(ON)}$ .

Drain on-leakage current is defined as the leakage current flowing into or out of the drain pin when the switch is on. This current is denoted by the symbol  $I_{D(ON)}$ .

Either the source pin or drain pin is left floating during the measurement. Figure 20 shows the circuit used for measuring the on-leakage current, denoted by  $I_{S(ON)}$  or  $I_{D(ON)}$ .

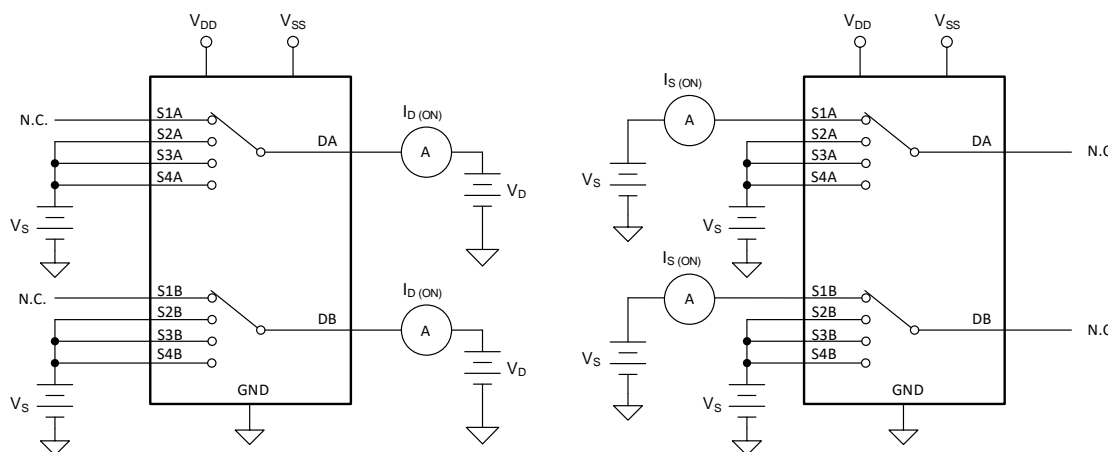

Figure 20. On-Leakage Measurement Setup

### 7.1.4 Transition Time

Transition time is defined as the time taken by the output of the device to rise or fall 10% after the address signal has risen or fallen past the logic threshold. The 10% transition measurement is utilized to provide the timing of the device, system level timing can then account for the time constant added from the load resistance and load capacitance. Figure 21 shows the setup used to measure transition time, denoted by the symbol  $t_{TRANSITION}$ .

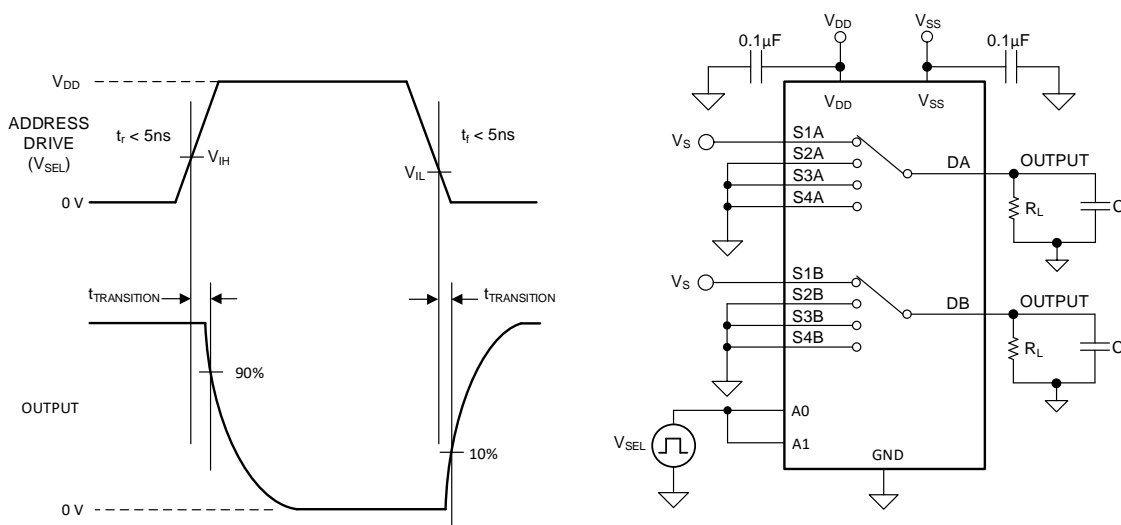

Figure 21. Transition-Time Measurement Setup

## Overview (continued)

### 7.1.5 Break-Before-Make

Break-before-make delay is a safety feature that prevents two inputs from connecting when the device is switching. The output first breaks from the on-state switch before making the connection with the next on-state switch. The time delay between the *break* and the *make* is known as break-before-make delay. Figure 22 shows the setup used to measure break-before-make delay, denoted by the symbol  $t_{OPEN(BBM)}$ .

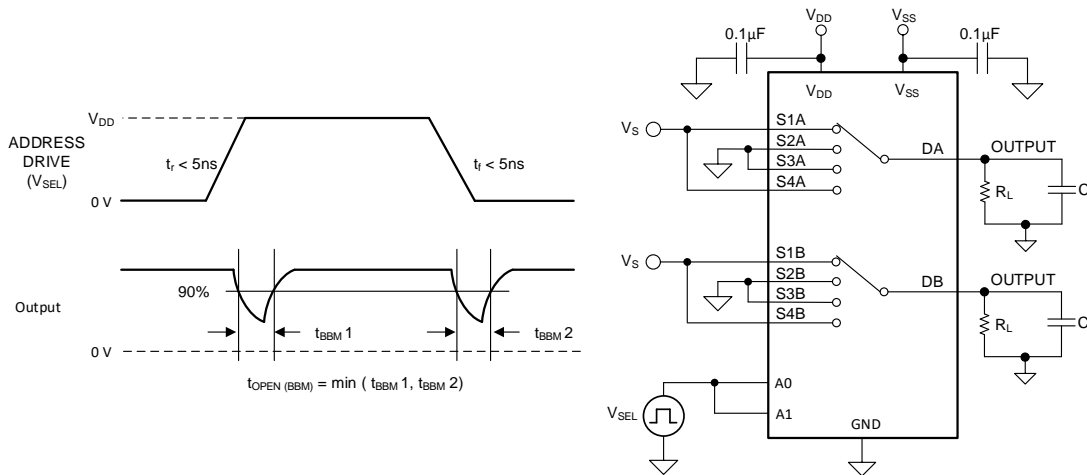

Figure 22. Break-Before-Make Delay Measurement Setup

### 7.1.6 $t_{ON(EN)}$ and $t_{OFF(EN)}$

Turn-on time is defined as the time taken by the output of the device to rise to 10% after the enable has risen past the logic threshold. The 10% measurement is utilized to provide the timing of the device, system level timing can then account for the time constant added from the load resistance and load capacitance. Figure 23 shows the setup used to measure turn-on time, denoted by the symbol  $t_{ON(EN)}$ .

Turn-off time is defined as the time taken by the output of the device to fall to 90% after the enable has fallen past the logic threshold. The 90% measurement is utilized to provide the timing of the device, system level timing can then account for the time constant added from the load resistance and load capacitance. Figure 23 shows the setup used to measure turn-off time, denoted by the symbol  $t_{OFF(EN)}$ .

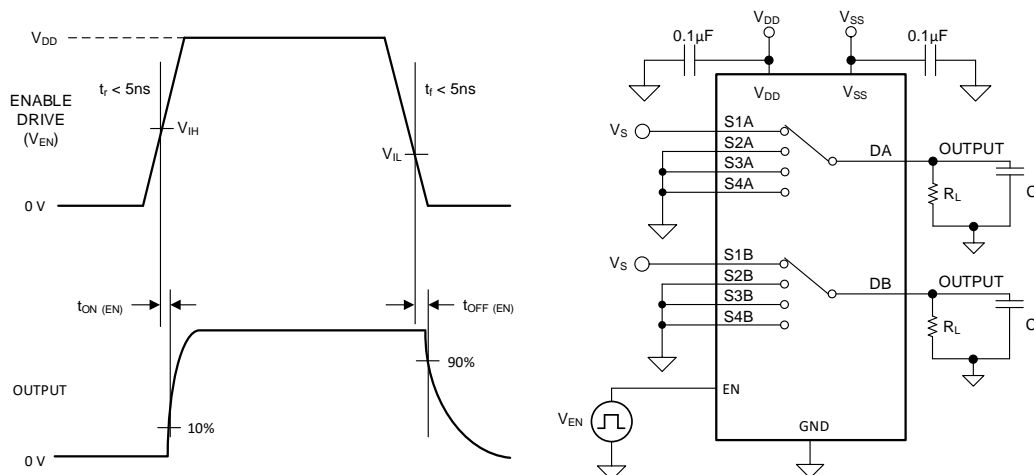

Figure 23. Turn-On and Turn-Off Time Measurement Setup

## Overview (continued)

### 7.1.7 Charge Injection

The TMUX1109 has a transmission-gate topology. Any mismatch in capacitance between the NMOS and PMOS transistors results in a charge injected into the drain or source during the falling or rising edge of the gate signal. The amount of charge injected into the source or drain of the device is known as charge injection, and is denoted by the symbol  $Q_C$ . Figure 24 shows the setup used to measure charge injection from source (Sx) to drain (D).

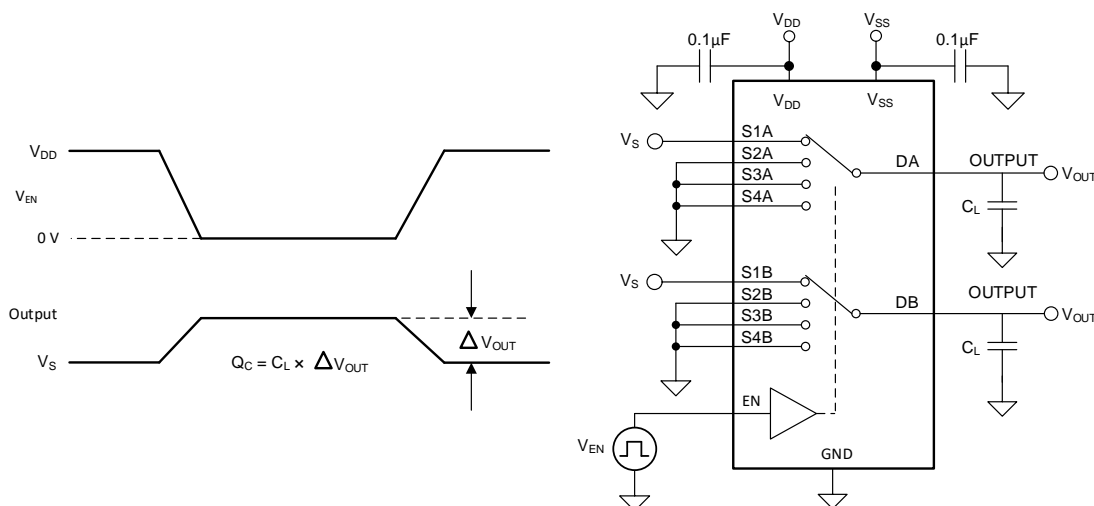

Figure 24. Charge-Injection Measurement Setup

### 7.1.8 Off Isolation

Off isolation is defined as the ratio of the signal at the drain pin (D) of the device when a signal is applied to the source pin (Sx) of an off-channel. Figure 25 shows the setup used to measure and the equation used to compute off isolation.

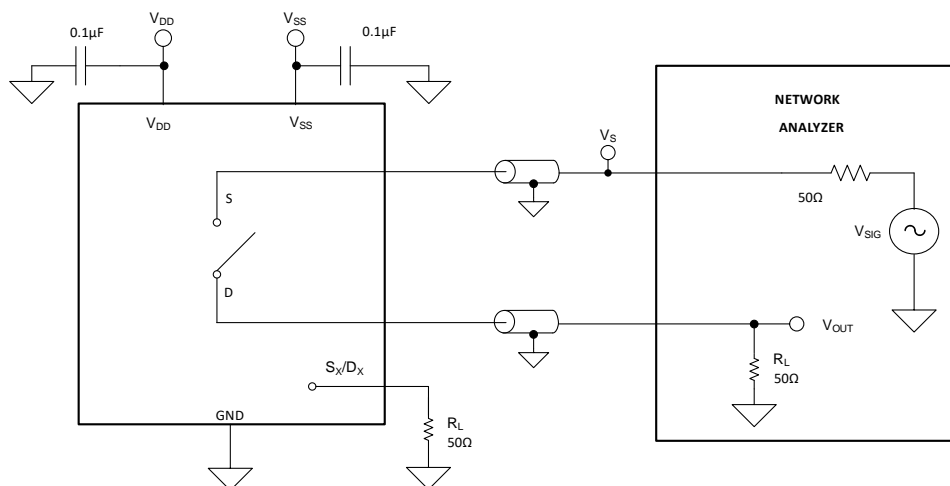

Figure 25. Off Isolation Measurement Setup

$$\text{Off Isolation} = 20 \cdot \text{Log} \left( \frac{V_{\text{OUT}}}{V_S} \right) \quad (1)$$

## Overview (continued)

### 7.1.9 Crosstalk

Crosstalk is defined as the ratio of the signal at the drain pin (D) of a different channel, when a signal is applied at the source pin (Sx) of an on-channel. [Figure 26](#) shows the setup used to measure, and the equation used to compute crosstalk.

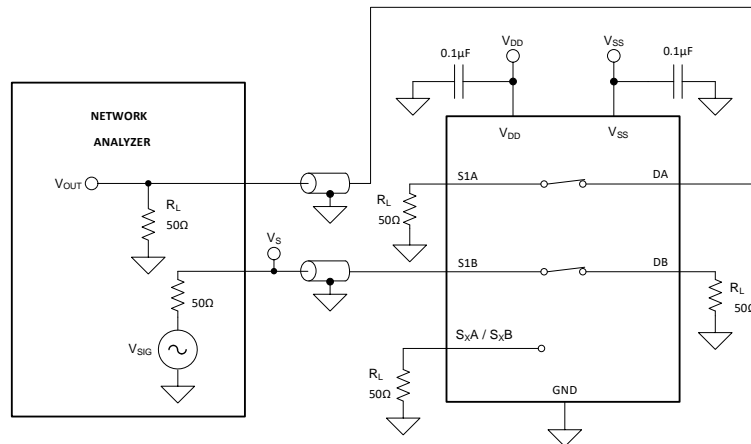
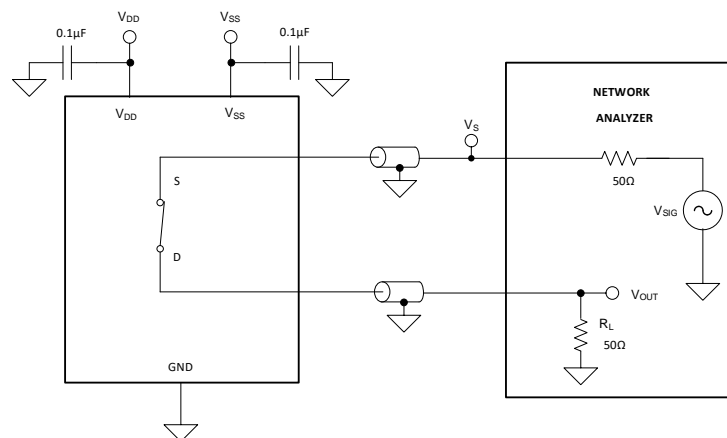

**Figure 26. Crosstalk Measurement Setup**

$$\text{Channel-to-Channel Crosstalk} = 20 \cdot \text{Log} \left( \frac{V_{\text{OUT}}}{V_{\text{S}}} \right) \quad (2)$$

### 7.1.10 Bandwidth

Bandwidth is defined as the range of frequencies that are attenuated by less than 3 dB when the input is applied to the source pin (Sx) of an on-channel, and the output is measured at the drain pin (D) of the device. [Figure 27](#) shows the setup used to measure bandwidth.



**Figure 27. Bandwidth Measurement Setup**

## 7.2 Functional Block Diagram

The TMUX1109 is an 4:1, differential (2-channel), multiplexer. Each switch is turned on or off based on the state of the address lines and enable pin.

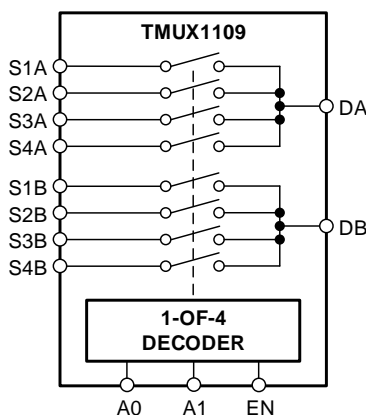

Figure 28. TMUX1109 Functional Block Diagram

## 7.3 Feature Description

### 7.3.1 Bidirectional Operation

The TMUX1109 conducts equally well from source (Sx) to drain (Dx) or from drain (Dx) to source (Sx). Each channel has very similar characteristics in both directions and supports both analog and digital signals.

### 7.3.2 Rail to Rail Operation

The valid signal path input/output voltage for TMUX1109 ranges from  $V_{SS}$  to  $V_{DD}$ .

### 7.3.3 1.8 V Logic Compatible Inputs

The TMUX1109 has 1.8-V logic compatible control for all logic control inputs. The logic input thresholds scale with supply but still provide 1.8-V logic control when operating at 5.5 V supply voltage. 1.8-V logic level inputs allows the TMUX1109 to interface with processors that have lower logic I/O rails and eliminates the need for an external translator, which saves both space and BOM cost. For more information on 1.8 V logic implementations refer to [Simplifying Design with 1.8 V logic Muxes and Switches](#)

### 7.3.4 Fail-Safe Logic

The TMUX1109 supports Fail-Safe Logic on the control input pins (EN, A0, A1) allowing for operation up to 5.5 V above  $V_{SS}$ , regardless of the state of the supply pin. This feature allows voltages on the control pins to be applied before the supply pin, protecting the device from potential damage. Fail-Safe Logic minimizes system complexity by removing the need for power supply sequencing on the logic control pins. For example, the Fail-Safe Logic feature allows the select pins of the TMUX1109 to be ramped to 5.5 V while  $V_{DD} = 0$  V. Additionally, the feature enables operation of the TMUX1109 with  $V_{DD} = 1.2$  V while allowing the select pins to interface with a logic level of another device up to 5.5 V.

## Feature Description (continued)

### 7.3.5 Ultra-low Leakage Current

The TMUX1109 provides extremely low on-leakage and off-leakage currents. The TMUX1109 is capable of switching signals from high source-impedance inputs into a high input-impedance op amp with minimal offset error because of the ultralow leakage currents. Figure 29 shows typical leakage currents of the TMUX1109 versus temperature.

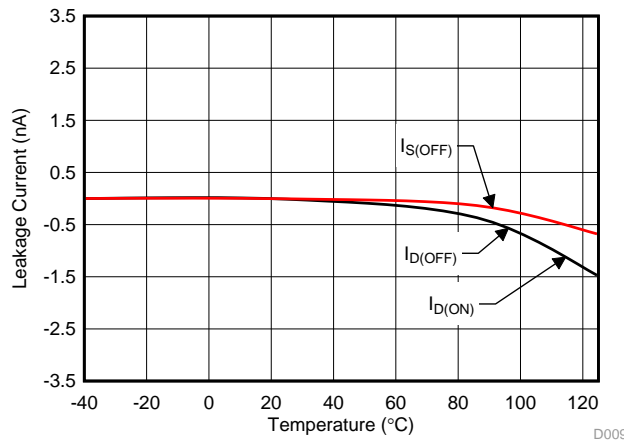

Figure 29. Leakage Current vs Temperature

### 7.3.6 Ultra-low Charge Injection

The TMUX1109 has a transmission gate topology, as shown in Figure 30. Any mismatch in the stray capacitance associated with the NMOS and PMOS causes an output level change whenever the switch is opened or closed.

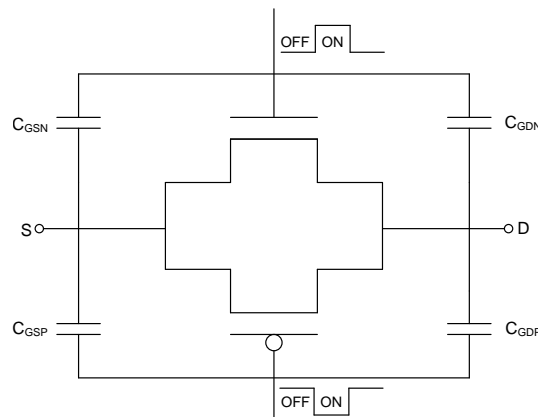

Figure 30. Transmission Gate Topology

The TMUX1109 has special charge-injection cancellation circuitry that reduces the source-to-drain charge injection to as low as 1 pC at  $V_S = 1$  V as shown in Figure 31.



## Feature Description (continued)

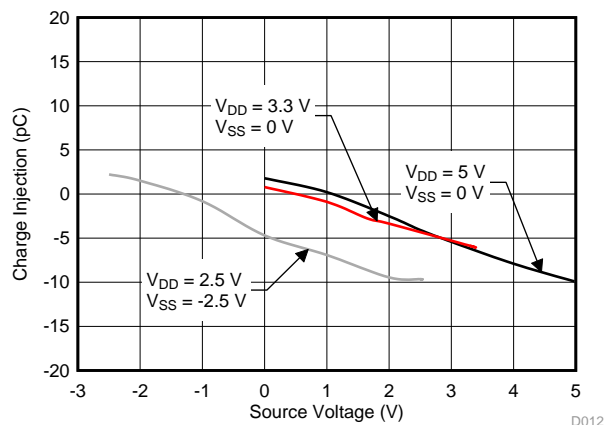

Figure 31. Charge Injection vs Source Voltage

## 7.4 Device Functional Modes

When the EN pin of the TMUX1109 is pulled high, one of the switches is closed based on the state of the address lines. When the EN pin is pulled low, all the switches are in an open state regardless of the state of the address lines.

### 7.4.1 Truth Tables

Table 1. TMUX1109 Truth Table

EN	A1	A0	Selected Input Connected To Drain (DA, DB) Pins
0	X <sup>(1)</sup>	X <sup>(1)</sup>	All channels are off
1	0	0	S1A and S1B
1	0	1	S2A and S2B
1	1	0	S3A and S3B
1	1	1	S4A and S4B

(1) X denotes *don't care*.

## 8 Application and Implementation

### NOTE

Information in the following applications sections is not part of the TI component specification, and TI does not warrant its accuracy or completeness. TI's customers are responsible for determining suitability of components for their purposes. Customers should validate and test their design implementation to confirm system functionality.

### 8.1 Application Information

The TMUX11xx family offers ultra-low input/output leakage currents and low charge injection. These devices operate up to 5.5 V, and offer true rail-to-rail input and output. The TMUX1109 has a low on-capacitance which allows faster settling time when multiplexing inputs in the time domain. These features make the TMUX11xx devices a family of precision, robust, high-performance analog multiplexer for low-voltage applications.

### 8.2 Typical Application

Figure 32 shows a 16-bit, simultaneous-sampling data-acquisition system. This example is typical in industrial applications that require sampling simultaneous signals such as Optical Modules, Analog Input Modules, and Motor Drive circuits for position feedback. The circuit uses eight Fully Differential Amplifiers (FDAs), a 16-bit, 3-MSPS successive-approximation-resistor (SAR) analog-to-digital converter (ADC), along with a two differential precision multiplexers. Refer to [True Differential, 4 x 2 MUX, Analog Front End, Simultaneous-Sampling ADC Circuit](#) for more information.

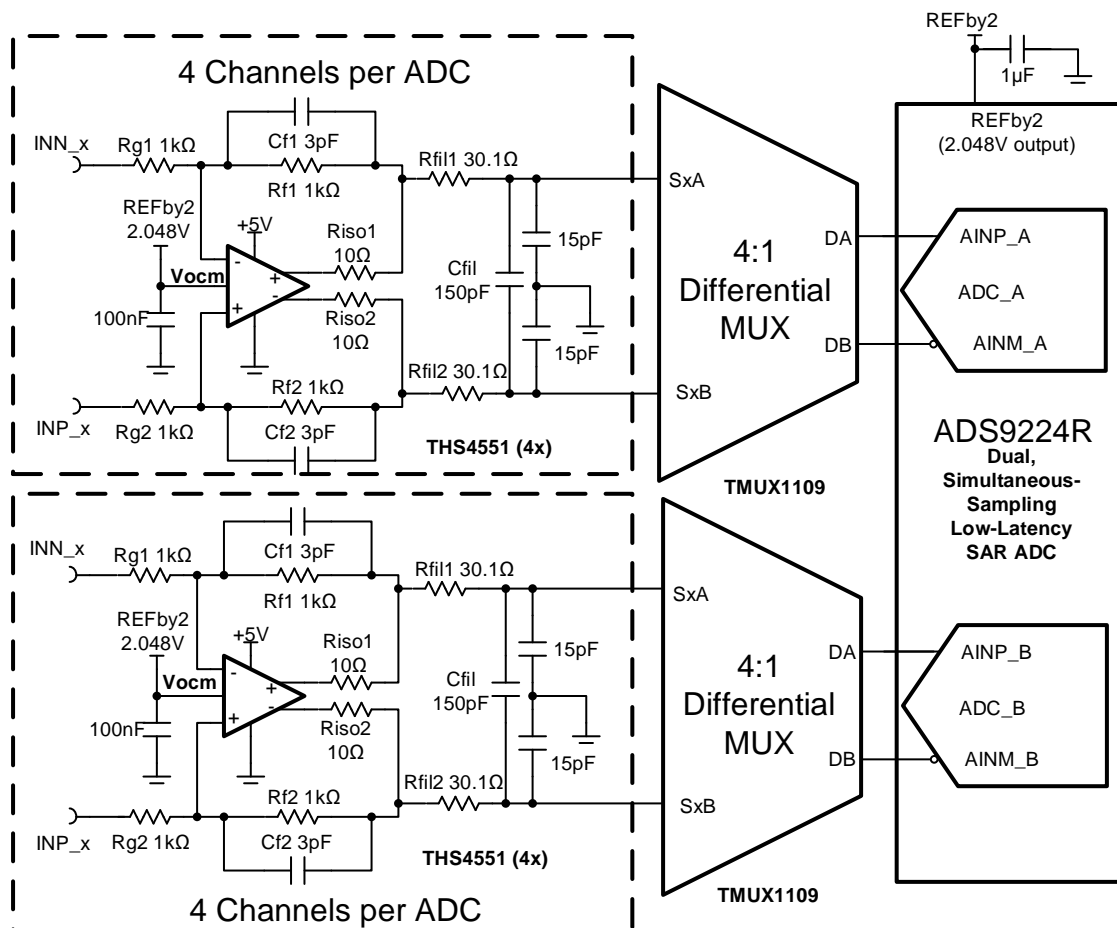

Figure 32. Simultaneous-Sampling ADC Circuit

### 8.3 Design Requirements

For this design example, use the parameters listed in [Table 2](#).

**Table 2. Design Parameters**

PARAMETERS	VALUES
Supply ( $V_{DD}$ )	5 V
Vref	4.096 V
Vocm	2.048 V
Max Differential Voltage	3.636 V
Control logic thresholds	1.8 V compatible

### 8.4 Detailed Design Procedure

The TMUX1109 can be operated without any external components except for the supply decoupling capacitors. If the device desired power-up state is disabled, the enable pin should have a weak pull-down resistor and be controlled by the MCU via GPIO. All inputs being muxed to the ADC must fall within the recommend operating conditions of the TMUX1109 including signal range and continuous current. System level design and component selection are made according to [True Differential, 4 x 2 MUX, Analog Front End, Simultaneous-Sampling ADC Circuit](#).

1. The ADS9224R was selected because of the dual simultaneous sampling and high throughput (3-MSPS).
2. The TMUX1109 4:1 (2x) multiplexer was selected to support 4 differential inputs for each ADC.
3. Find ADC full-scale range, resolution and common-mode range specifications.
4. Determine the linear range of the FDA (THS4551) based on common-mode and output swing specification.
5. Select COG capacitors for all filter capacitors at the ADC input to minimize distortion.
6. Select the FDA gain resistors  $RF_{1,2}$ ,  $RG_{1,2}$ . Use 0.1% 20ppm/°C film resistors or better for good accuracy, low gain drift and to minimize distortion.
7. [Introduction to SAR ADC Front-End Component Selection](#) covers the methods for selecting the charge bucket circuit  $R_{fil1}$ ,  $R_{fil}$  and  $C_{fil}$ . These component values are dependent on the amplifier bandwidth, data converter sampling rate, and data converter design. The values shown here will give good settling and AC performance for the amplifier and data converter in this example. If the design is modified, a different RC filter must be selected.
8. The THS4551 is commonly used in high-speed precision fully differential SAR applications as it has sufficient bandwidth to settle to charge kickback transients from the ADC input sampling, and multiplexer charge injection and provides the common-mode level shifting to the voltage range of the SAR ADC.
9. The TMUX1109 is used in high-speed precision fully differential SAR applications as it has sufficient bandwidth, low charge injection, and low on-resistance and capacitance. Low capacitance supports fast switching between channels and allows the system to settle within required precision in the specified timing.

## 8.5 Application Curve

Charge injection impacts system performance and settling characteristics of the charge bucket circuit. A multiplexer with low charge injection and a flat response across input voltage allows the system to settle to the required precision during the ADC acquisition period. Figure 33 shows the flat charge injection of the TMUX1109 at multiple supply voltages.

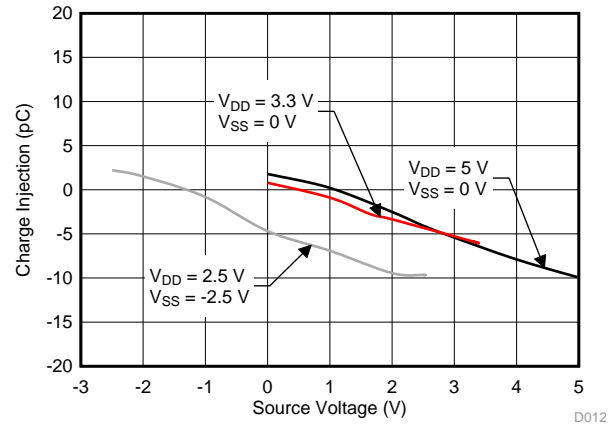

$T_A = 25^\circ\text{C}$

**Figure 33. Charge Injection vs Source Voltage**

## 9 Power Supply Recommendations

The TMUX1109 operates across a wide supply range of 1.08 V to 5.5 V, or  $\pm 2.5$  V. Do not exceed the absolute maximum ratings because stresses beyond the listed ratings can cause permanent damage to the devices.

Power-supply bypassing improves noise margin and prevents switching noise propagation from the  $V_{DD}$  and  $V_{SS}$  supplies to other components. Good power-supply decoupling is important to achieve optimum performance. For improved supply noise immunity, use a supply decoupling capacitor ranging from 0.1  $\mu\text{F}$  to 10  $\mu\text{F}$  from  $V_{DD}$  and  $V_{SS}$  to ground. Place the bypass capacitors as close to the power supply pins of the device as possible using low-impedance connections. TI recommends using multi-layer ceramic chip capacitors (MLCCs) that offer low equivalent series resistance (ESR) and inductance (ESL) characteristics for power-supply decoupling purposes. For very sensitive systems, or for systems in harsh noise environments, avoiding the use of vias for connecting the capacitors to the device pins may offer superior noise immunity. The use of multiple vias in parallel lowers the overall inductance and is beneficial for connections to ground planes.

## 10 Layout

### 10.1 Layout Guidelines

#### 10.1.1 Layout Information

When a PCB trace turns a corner at a 90° angle, a reflection can occur. A reflection occurs primarily because of the change of width of the trace. At the apex of the turn, the trace width increases to 1.414 times the width. This increase upsets the transmission-line characteristics, especially the distributed capacitance and self-inductance of the trace which results in the reflection. Not all PCB traces can be straight and therefore some traces must turn corners. Figure 34 shows progressively better techniques of rounding corners. Only the last example (BEST) maintains constant trace width and minimizes reflections.

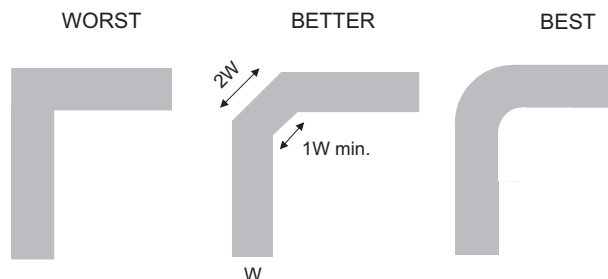

Figure 34. Trace Example

Route high-speed signals using a minimum of vias and corners which reduces signal reflections and impedance changes. When a via must be used, increase the clearance size around it to minimize its capacitance. Each via introduces discontinuities in the signal's transmission line and increases the chance of picking up interference from the other layers of the board. Be careful when designing test points, through-hole pins are not recommended at high frequencies.

Figure 35 illustrates an example of a PCB layout with the TMUX1109. Some key considerations are:

- Decouple the  $V_{DD}$  pin with a 0.1- $\mu\text{F}$  capacitor, placed as close to the pin as possible. Make sure that the capacitor voltage rating is sufficient for the  $V_{DD}$  supply.
- Keep the input lines as short as possible.
- Use a solid ground plane to help reduce electromagnetic interference (EMI) noise pickup.
- Do not run sensitive analog traces in parallel with digital traces. Avoid crossing digital and analog traces if possible, and only make perpendicular crossings when necessary.

### 10.2 Layout Example

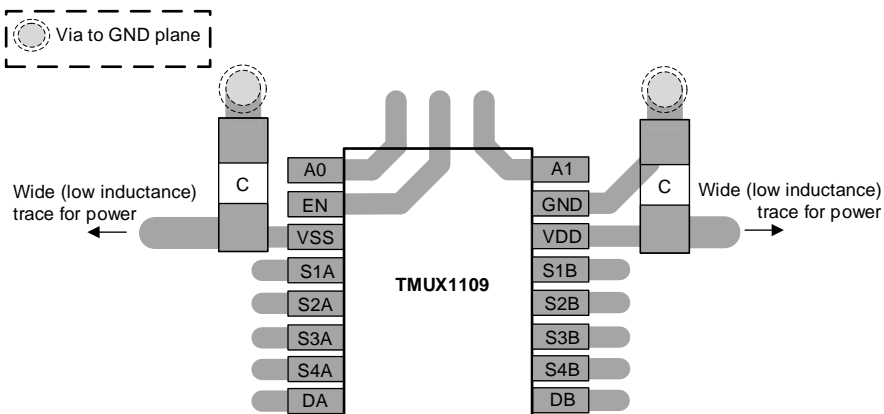

Figure 35. TMUX1109 Layout Example

## 11 Device and Documentation Support

### 11.1 Documentation Support

#### 11.1.1 Related Documentation

Texas Instruments, [True Differential, 4 x 2 MUX, Analog Front End, Simultaneous-Sampling ADC Circuit](#).

Texas Instruments, [Improve Stability Issues with Low CON Multiplexers](#).

Texas Instruments, [Simplifying Design with 1.8 V logic Muxes and Switches](#).

Texas Instruments, [Eliminate Power Sequencing with Powered-off Protection Signal Switches](#).

Texas Instruments, [System-Level Protection for High-Voltage Analog Multiplexers](#).

Texas Instruments, [QFN/SON PCB Attachment](#).

Texas Instruments, [Quad Flatpack No-Lead Logic Packages](#).

#### 11.2 Related Links

The table below lists quick access links. Categories include technical documents, support and community resources, tools and software, and quick access to order now.

#### 11.3 Receiving Notification of Documentation Updates

To receive notification of documentation updates, navigate to the device product folder on ti.com. In the upper right corner, click on *Alert me* to register and receive a weekly digest of any product information that has changed. For change details, review the revision history included in any revised document.

#### 11.4 Community Resources

The following links connect to TI community resources. Linked contents are provided "AS IS" by the respective contributors. They do not constitute TI specifications and do not necessarily reflect TI's views; see TI's [Terms of Use](#).

**TI E2E™ Online Community** *TI's Engineer-to-Engineer (E2E) Community*. Created to foster collaboration among engineers. At e2e.ti.com, you can ask questions, share knowledge, explore ideas and help solve problems with fellow engineers.

**Design Support** *TI's Design Support* Quickly find helpful E2E forums along with design support tools and contact information for technical support.

#### 11.5 Trademarks

E2E is a trademark of Texas Instruments.

#### 11.6 Electrostatic Discharge Caution



This integrated circuit can be damaged by ESD. Texas Instruments recommends that all integrated circuits be handled with appropriate precautions. Failure to observe proper handling and installation procedures can cause damage.

ESD damage can range from subtle performance degradation to complete device failure. Precision integrated circuits may be more susceptible to damage because very small parametric changes could cause the device not to meet its published specifications.

#### 11.7 Glossary

[SLYZ022](#) — *TI Glossary*.

This glossary lists and explains terms, acronyms, and definitions.

## 12 Mechanical, Packaging, and Orderable Information

The following pages include mechanical, packaging, and orderable information. This information is the most current data available for the designated devices. This data is subject to change without notice and revision of this document. For browser-based versions of this data sheet, refer to the left-hand navigation.

**PACKAGING INFORMATION**

Orderable Device	Status (1)	Package Type	Package Drawing	Pins	Package Qty	Eco Plan (2)	Lead/Ball Finish (6)	MSL Peak Temp (3)	Op Temp (°C)	Device Marking (4/5)	Samples
TMUX1109PWR	ACTIVE	TSSOP	PW	16	2000	Green (RoHS & no Sb/Br)	CU NIPDAU	Level-1-260C-UNLIM	-40 to 125	TM1109	<a href="#">Samples</a>
TMUX1109RSVR	ACTIVE	UQFN	RSV	16	3000	Green (RoHS & no Sb/Br)	CU NIPDAUAG	Level-1-260C-UNLIM	-40 to 125	1D1	<a href="#">Samples</a>

(1) The marketing status values are defined as follows:

**ACTIVE:** Product device recommended for new designs.

**LIFEBUY:** TI has announced that the device will be discontinued, and a lifetime-buy period is in effect.

**NRND:** Not recommended for new designs. Device is in production to support existing customers, but TI does not recommend using this part in a new design.

**PREVIEW:** Device has been announced but is not in production. Samples may or may not be available.

**OBSOLETE:** TI has discontinued the production of the device.

(2) **RoHS:** TI defines "RoHS" to mean semiconductor products that are compliant with the current EU RoHS requirements for all 10 RoHS substances, including the requirement that RoHS substance do not exceed 0.1% by weight in homogeneous materials. Where designed to be soldered at high temperatures, "RoHS" products are suitable for use in specified lead-free processes. TI may reference these types of products as "Pb-Free".

**RoHS Exempt:** TI defines "RoHS Exempt" to mean products that contain lead but are compliant with EU RoHS pursuant to a specific EU RoHS exemption.

**Green:** TI defines "Green" to mean the content of Chlorine (Cl) and Bromine (Br) based flame retardants meet JS709B low halogen requirements of <=1000ppm threshold. Antimony trioxide based flame retardants must also meet the <=1000ppm threshold requirement.

(3) MSL, Peak Temp. - The Moisture Sensitivity Level rating according to the JEDEC industry standard classifications, and peak solder temperature.

(4) There may be additional marking, which relates to the logo, the lot trace code information, or the environmental category on the device.

(5) Multiple Device Markings will be inside parentheses. Only one Device Marking contained in parentheses and separated by a "~" will appear on a device. If a line is indented then it is a continuation of the previous line and the two combined represent the entire Device Marking for that device.

(6) Lead/Ball Finish - Orderable Devices may have multiple material finish options. Finish options are separated by a vertical ruled line. Lead/Ball Finish values may wrap to two lines if the finish value exceeds the maximum column width.

**Important Information and Disclaimer:**The information provided on this page represents TI's knowledge and belief as of the date that it is provided. TI bases its knowledge and belief on information provided by third parties, and makes no representation or warranty as to the accuracy of such information. Efforts are underway to better integrate information from third parties. TI has taken and continues to take reasonable steps to provide representative and accurate information but may not have conducted destructive testing or chemical analysis on incoming materials and chemicals. TI and TI suppliers consider certain information to be proprietary, and thus CAS numbers and other limited information may not be available for release.

In no event shall TI's liability arising out of such information exceed the total purchase price of the TI part(s) at issue in this document sold by TI to Customer on an annual basis.





## TAPE AND REEL INFORMATION



### QUADRANT ASSIGNMENTS FOR PIN 1 ORIENTATION IN TAPE



\*All dimensions are nominal

Device	Package Type	Package Drawing	Pins	SPQ	Reel Diameter (mm)	Reel Width W1 (mm)	A0 (mm)	B0 (mm)	K0 (mm)	P1 (mm)	W (mm)	Pin1 Quadrant
TMUX1109PWR	TSSOP	PW	16	2000	330.0	12.4	6.9	5.6	1.6	8.0	12.0	Q1
TMUX1109RSVR	UQFN	RSV	16	3000	178.0	13.5	2.1	2.9	0.75	4.0	12.0	Q1

**TAPE AND REEL BOX DIMENSIONS**

\*All dimensions are nominal

Device	Package Type	Package Drawing	Pins	SPQ	Length (mm)	Width (mm)	Height (mm)
TMUX1109PWR	TSSOP	PW	16	2000	367.0	367.0	35.0
TMUX1109RSVR	UQFN	RSV	16	3000	189.0	185.0	36.0



4220204/A 02/2017

NOTES:

1. All linear dimensions are in millimeters. Any dimensions in parenthesis are for reference only. Dimensioning and tolerancing per ASME Y14.5M.
2. This drawing is subject to change without notice.
3. This dimension does not include mold flash, protrusions, or gate burrs. Mold flash, protrusions, or gate burrs shall not exceed 0.15 mm per side.
4. This dimension does not include interlead flash. Interlead flash shall not exceed 0.25 mm per side.
5. Reference JEDEC registration MO-153.

# EXAMPLE BOARD LAYOUT

PW0016A

TSSOP - 1.2 mm max height

SMALL OUTLINE PACKAGE



LAND PATTERN EXAMPLE  
EXPOSED METAL SHOWN  
SCALE: 10X



SOLDER MASK DETAILS

4220204/A 02/2017

NOTES: (continued)

- 6. Publication IPC-7351 may have alternate designs.
- 7. Solder mask tolerances between and around signal pads can vary based on board fabrication site.

# EXAMPLE STENCIL DESIGN

PW0016A

TSSOP - 1.2 mm max height

SMALL OUTLINE PACKAGE



SOLDER PASTE EXAMPLE  
BASED ON 0.125 mm THICK STENCIL  
SCALE: 10X

4220204/A 02/2017

NOTES: (continued)

8. Laser cutting apertures with trapezoidal walls and rounded corners may offer better paste release. IPC-7525 may have alternate design recommendations.
9. Board assembly site may have different recommendations for stencil design.



# EXAMPLE BOARD LAYOUT

RSV0016A

UQFN - 0.55 mm max height

ULTRA THIN QUAD FLATPACK - NO LEAD

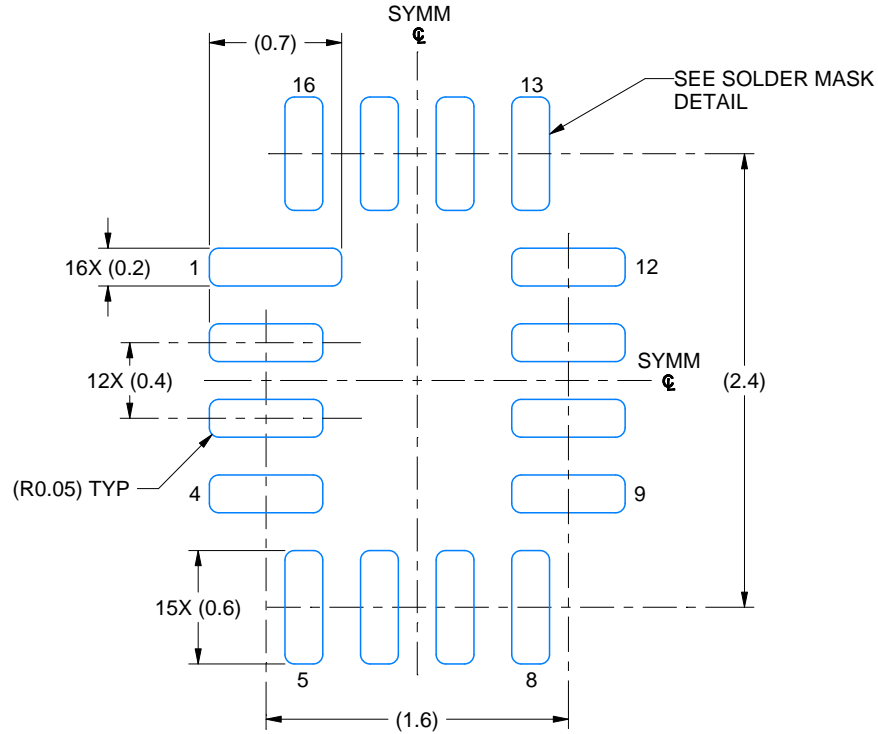

LAND PATTERN EXAMPLE  
EXPOSED METAL SHOWN  
SCALE: 25X

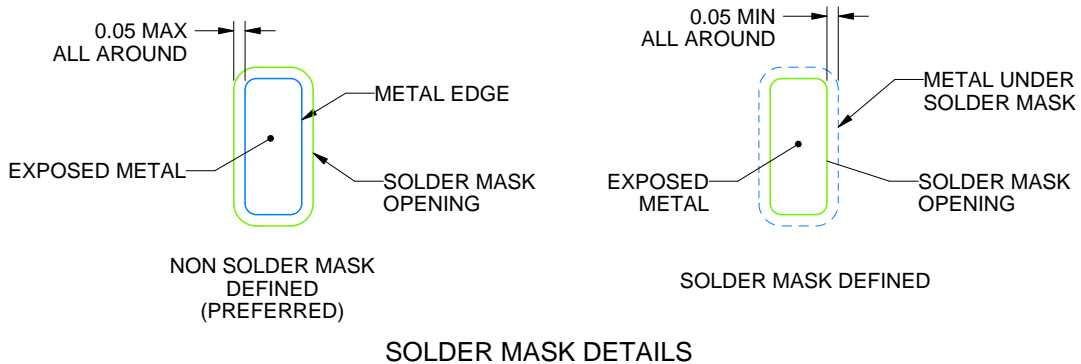

SOLDER MASK DETAILS

4220314/B 05/2019

NOTES: (continued)

- This package is designed to be soldered to a thermal pad on the board. For more information, see Texas Instruments literature number SLUA271 ([www.ti.com/lit/slua271](http://www.ti.com/lit/slua271)).

# EXAMPLE STENCIL DESIGN

RSV0016A

UQFN - 0.55 mm max height

ULTRA THIN QUAD FLATPACK - NO LEAD

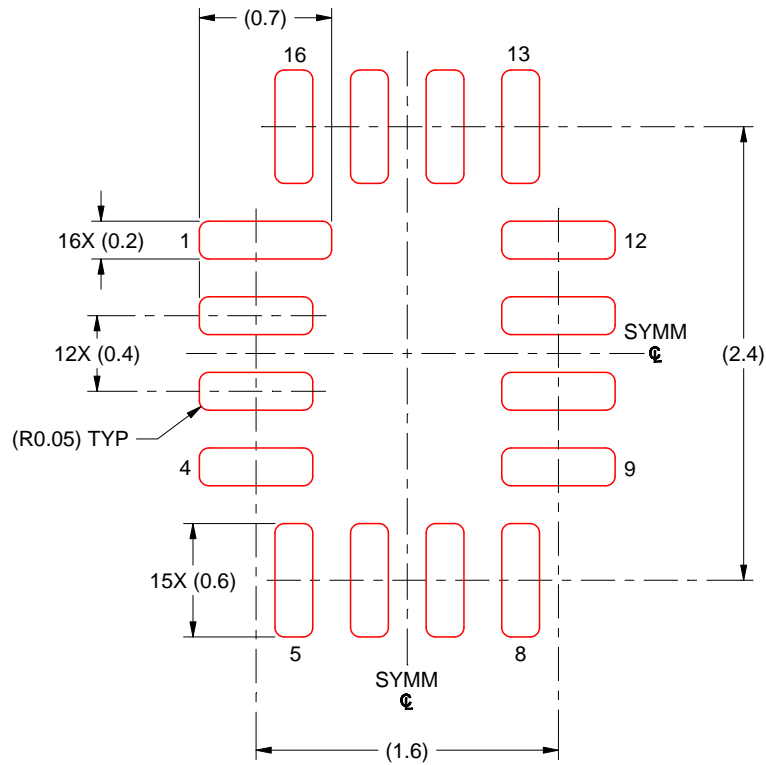

SOLDER PASTE EXAMPLE  
BASED ON 0.125 MM THICK STENCIL  
SCALE: 25X

4220314/B 05/2019

NOTES: (continued)

4. Laser cutting apertures with trapezoidal walls and rounded corners may offer better paste release. IPC-7525 may have alternate design recommendations.



## IMPORTANT NOTICE AND DISCLAIMER

TI PROVIDES TECHNICAL AND RELIABILITY DATA (INCLUDING DATASHEETS), DESIGN RESOURCES (INCLUDING REFERENCE DESIGNS), APPLICATION OR OTHER DESIGN ADVICE, WEB TOOLS, SAFETY INFORMATION, AND OTHER RESOURCES "AS IS" AND WITH ALL FAULTS, AND DISCLAIMS ALL WARRANTIES, EXPRESS AND IMPLIED, INCLUDING WITHOUT LIMITATION ANY IMPLIED WARRANTIES OF MERCHANTABILITY, FITNESS FOR A PARTICULAR PURPOSE OR NON-INFRINGEMENT OF THIRD PARTY INTELLECTUAL PROPERTY RIGHTS.

These resources are intended for skilled developers designing with TI products. You are solely responsible for (1) selecting the appropriate TI products for your application, (2) designing, validating and testing your application, and (3) ensuring your application meets applicable standards, and any other safety, security, or other requirements. These resources are subject to change without notice. TI grants you permission to use these resources only for development of an application that uses the TI products described in the resource. Other reproduction and display of these resources is prohibited. No license is granted to any other TI intellectual property right or to any third party intellectual property right. TI disclaims responsibility for, and you will fully indemnify TI and its representatives against, any claims, damages, costs, losses, and liabilities arising out of your use of these resources.

TI's products are provided subject to TI's Terms of Sale ([www.ti.com/legal/termsofsale.html](http://www.ti.com/legal/termsofsale.html)) or other applicable terms available either on [ti.com](http://ti.com) or provided in conjunction with such TI products. TI's provision of these resources does not expand or otherwise alter TI's applicable warranties or warranty disclaimers for TI products.

Mailing Address: Texas Instruments, Post Office Box 655303, Dallas, Texas 75265  
Copyright © 2019, Texas Instruments Incorporated