

General Description

The MIC5011 is the “minimum parts count” member of the Micrel MIC501X driver family. These ICs are designed to drive the gate of an N-channel power MOSFET above the supply rail in high-side power switch applications. The 8-pin MIC5011 is extremely easy to use, requiring only a power FET and nominal supply decoupling to implement either a high- or low-side switch.

The MIC5011 charges a 1nF load in 60µs typical with no external components. Faster switching is achieved by adding two 1nF charge pump capacitors. Operation down to 4.75V allows the MIC5011 to drive standard MOSFETs in 5V low-side applications by boosting the gate voltage above the logic supply. In addition, multiple paralleled MOSFETs can be driven by a single MIC5011 for ultra-high current applications.

Other members of the Micrel driver family include the MIC5013 protected 8-pin driver.

For new designs, Micrel recommends the pin-compatible MIC5014 MOSFET driver.

Features

- 4.75V to 32V operation
- Less than 1µA standby current in the “off” state
- Internal charge pump to drive the gate of an N-channel power FET above supply
- Available in small outline SOIC packages
- Internal zener clamp for gate protection
- Minimum external parts count
- Can be used to boost drive to low-side power FETs operating on logic supplies
- 25µs typical turn-on time with optional external capacitors
- Implements high- or low-side drivers

Applications

- Lamp drivers
- Relay and solenoid drivers
- Heater switching
- Power bus switching

Typical Applications

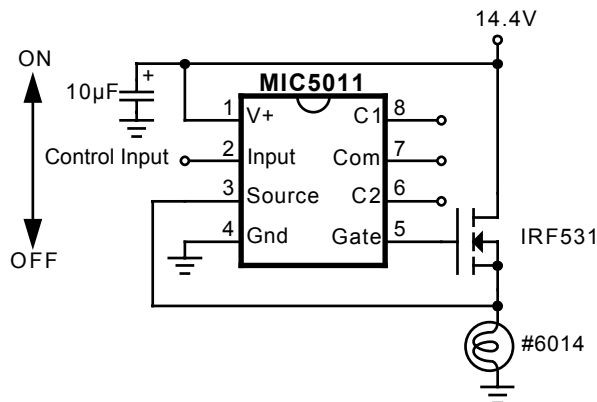

Figure 1. High Side Driver

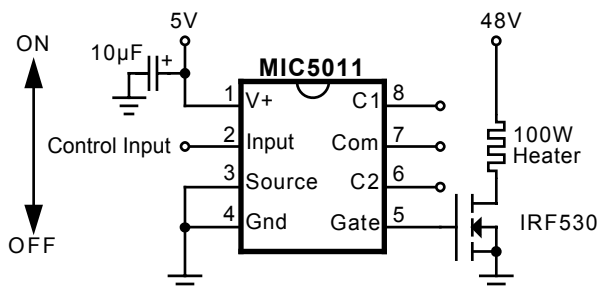

Figure 2. Low Side Driver

Ordering Information

Part Number		Temperature Range	Package
Standard	Pb-Free		
MIC5011BN	MIC5011YN	-40°C to +85°C	8-pin Plastic DIP
MIC5011BM	MIC5011YM	-40°C to +85°C	8-pin SOIC

Note: The MIC5011 is ESD sensitive.

Protected under one or more of the following Micrel patents:
patent #4,951,101; patent #4,914,546

Absolute Maximum Ratings (Note 1, 2)

Supply Voltage (V ⁺), Pin 1	-0.5V to 36V
Input Voltage, Pin 2	-10V to V ⁺
Source Voltage, Pin 3	-10V to V ⁺
Current into Pin 3	50mA
Gate Voltage, Pin 5	-1V to 50V
Junction Temperature	150°C

Operating Ratings (Notes 1, 2)

Power Dissipation	1.25W
θ_{JA} (Plastic DIP)	100°C/W
θ_{JA} (SOIC)	170°C/W
Ambient Temperature: B version	-40°C to +85°C
Storage Temperature	-65°C to +150°C
Lead Temperature (Soldering, 10 seconds)	260°C
Supply Voltage (V ⁺), Pin 1	4.75V to 32V high side 4.75V to 15V low side

Pin Description (Refer to **Typical Applications**)

Pin Number	Pin Name	Pin Function
1	V ⁺	Supply; must be decoupled to isolate from large transients caused by the power FET drain. 10 μ F is recommended close to pins 1 and 4.
2	Input	Turns on power MOSFET when taken above threshold (3.5V typical). Requires <1 μ A to switch.
3	Source	Connects to source lead of power FET and is the return for the gate clamp zener. Can safely swing to -10V when turning off inductive loads.
4	Ground	
5	Gate	Drives and clamps the gate of the power FET. Will be clamped to approximately -0.7V by an internal diode when turning off inductive loads.
6, 7, 8	C2, Com, C1	Optional 1nF capacitors reduce gate turn-on time; C2 has dominant effect.

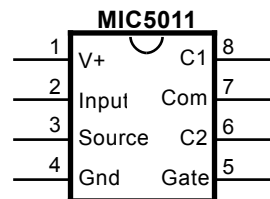
Pin Configuration

Electrical Characteristics (Note 3)

Test circuit. $T_A = -55^\circ\text{C}$ to $+125^\circ\text{C}$, $V^+ = 15\text{V}$, all switches open, unless otherwise specified.

Parameter	Conditions	Min	Typical	Max	Units	
Supply Current, I_1	$V^+ = 32\text{V}$	$V_{\text{IN}} = 0\text{V}$, S2 closed	0.1	10	μA	
		$V_{\text{IN}} = V^+ = 32\text{V}$	8	20	mA	
	$V^+ = 5\text{V}$	$V_{\text{IN}} = 5\text{V}$, S2 closed		1.6	4	mA
Logic Input Voltage	$V^+ = 4.75\text{V}$	Adjust V_{IN} for V_{GATE} low			2	V
		Adjust V_{IN} for V_{GATE} high	4.5			V
	$V^+ = 15\text{V}$	Adjust V_{IN} for V_{GATE} high	5.0			V
Logic Input Current, I_2	$V^+ = 32\text{V}$	$V_{\text{IN}} = 0\text{V}$	-1			μA
		$V_{\text{IN}} = 32\text{V}$			1	μA
Input Capacitance	Pin 2		5		pF	
Gate Drive, V_{GATE}	S1, S2 closed, $V_S = V^+$, $V_{\text{IN}} = 5\text{V}$	$V^+ = 4.75\text{V}$, $I_{\text{GATE}} = 0$, $V_{\text{IN}} = 4.5\text{V}$	7	10		V
		$V^+ = 15\text{V}$, $I_{\text{GATE}} = 100\mu\text{A}$, $V_{\text{IN}} = 5\text{V}$	24	27		V
Zener Clamp, $V_{\text{GATE}} - V_{\text{SOURCE}}$	S2 closed, $V_{\text{IN}} = 5\text{V}$	$V^+ = 15\text{V}$, $V_S = 15\text{V}$	11	12.5	15	V
		$V^+ = 32\text{V}$, $V_S = 32\text{V}$	11	13	16	V
Gate Turn-on Time, t_{ON} (Note 4)	V_{IN} switched from 0 to 5V; measure time for V_{GATE} to reach 20V		25	50	μs	
Gate Turn-off Time, t_{OFF}	V_{IN} switched from 5 to 0V; measure time for V_{GATE} to reach 1V		4	10	μs	

Note 1 **Absolute Maximum Ratings** indicate limits beyond which damage to the device may occur. Electrical specifications do not apply when operating the device beyond its specified **Operating Ratings**.

Note 2 The MIC5011 is ESD sensitive.

Note 3 Minimum and maximum **Electrical Characteristics** are 100% tested at $T_A = 25^\circ\text{C}$ and $T_A = 85^\circ\text{C}$, and 100% guaranteed over the entire range. Typicals are characterized at 25°C and represent the most likely parametric norm.

Note 4 Test conditions reflect worst case high-side driver performance. Low-side and bootstrapped topologies are significantly faster—see **Applications Information**. Maximum value of switching speed seen at 125°C , units operated at room temperature will reflect the typical values shown.

Test Circuit

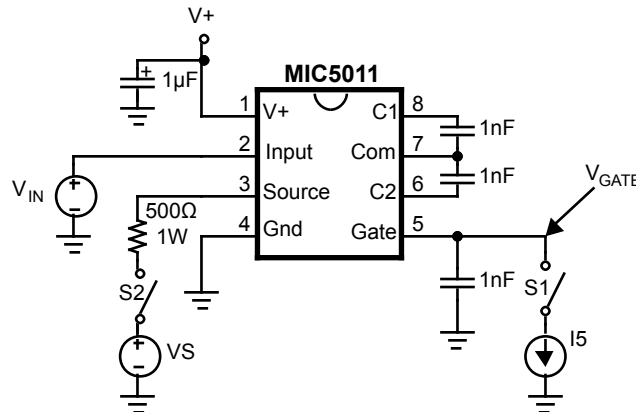

Typical Characteristics (Continued)

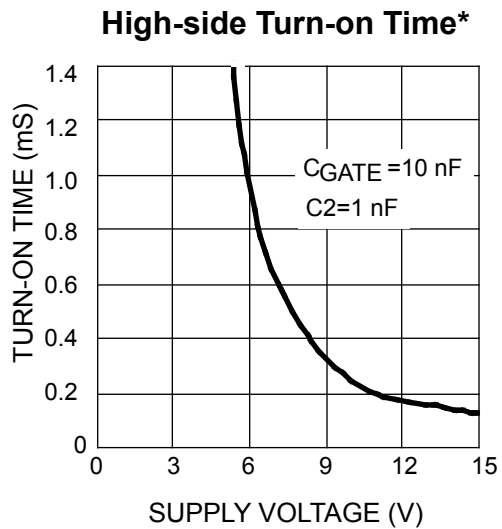
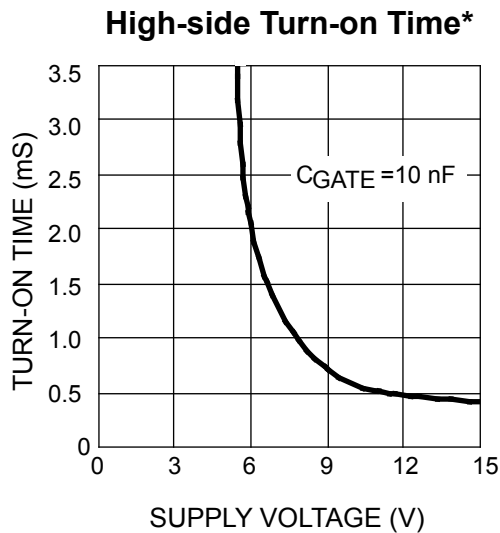
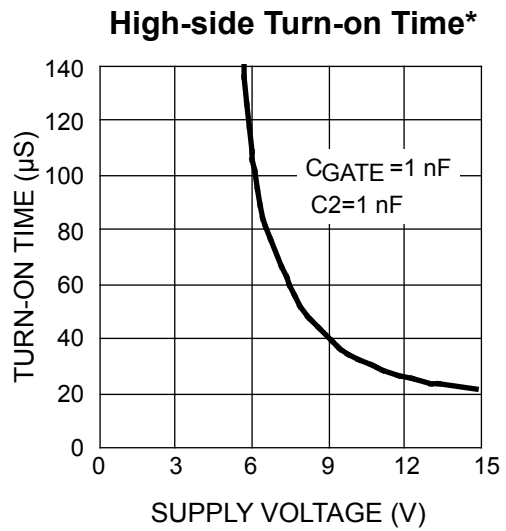
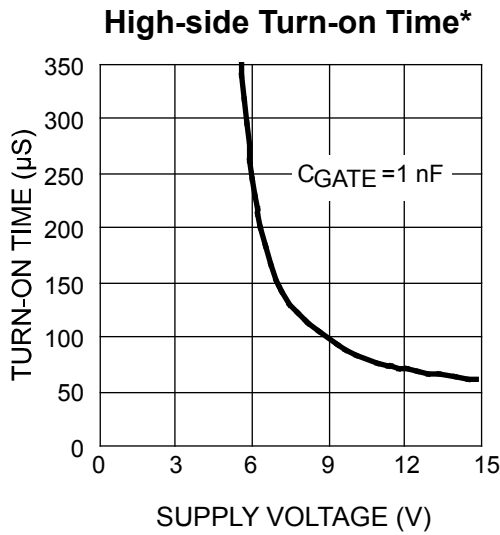
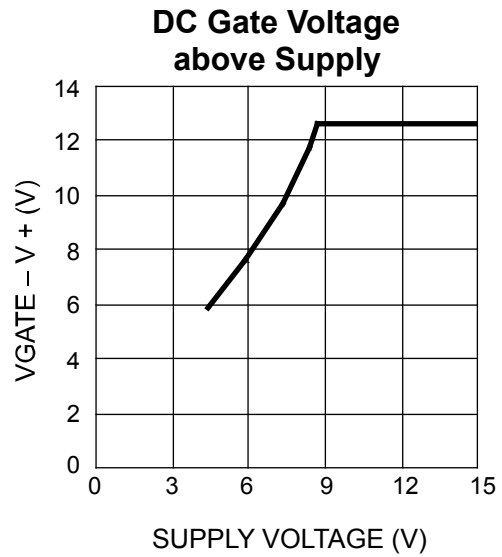
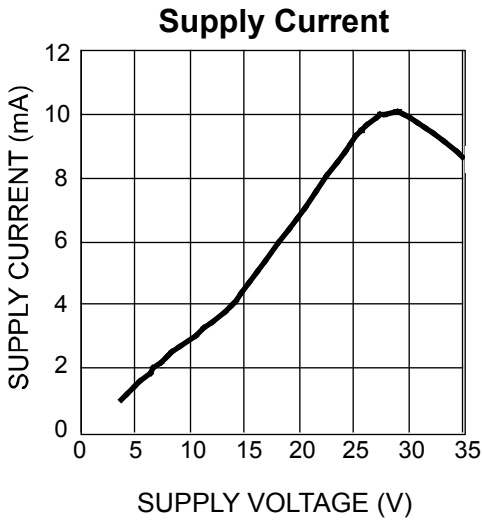

* Time for gate to reach V⁺ + 5V in test circuit with V_S = V⁺ - 5V.

Typical Characteristics (Continued)

Low-side Turn-on Time for Gate = 5V

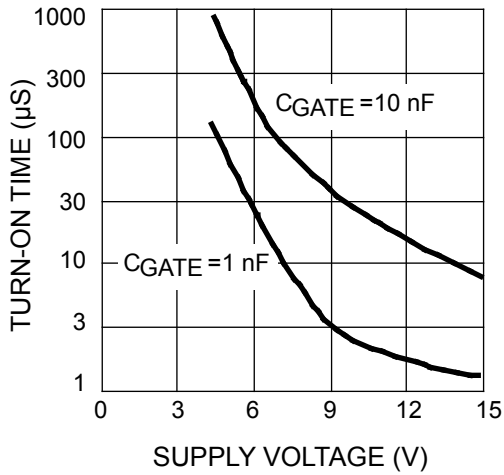

Low-side Turn-on Time for Gate = 5V

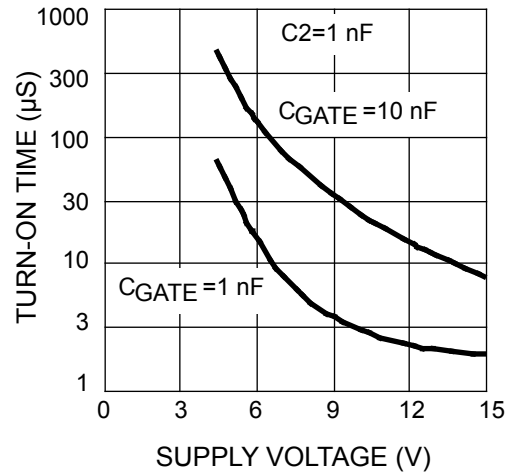

Low-side Turn-on Time for Gate = 10V

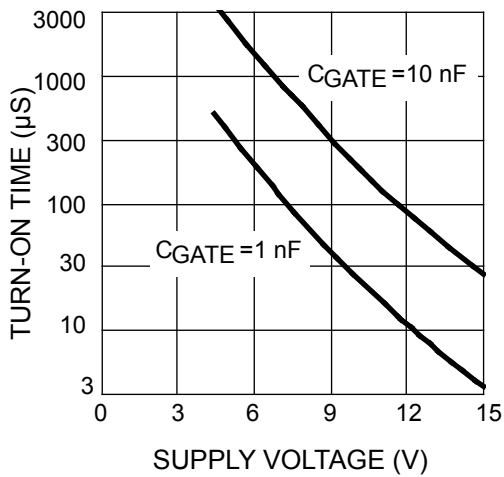

Low-side Turn-on Time for Gate = 10V

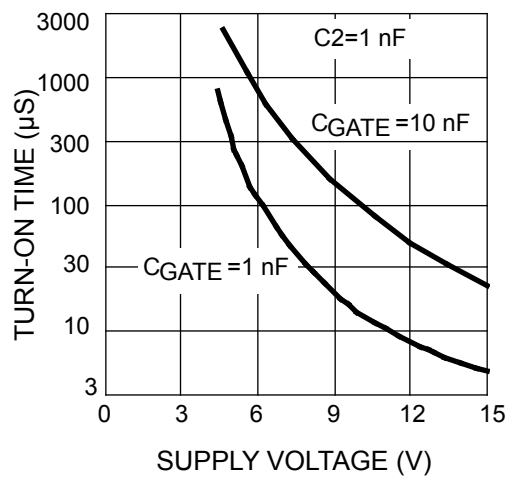

Turn-off Time

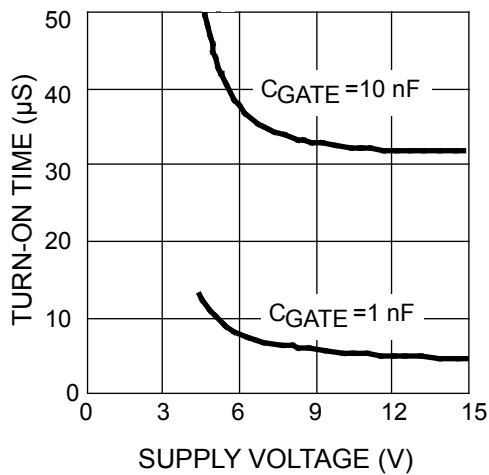

Turn-on Time

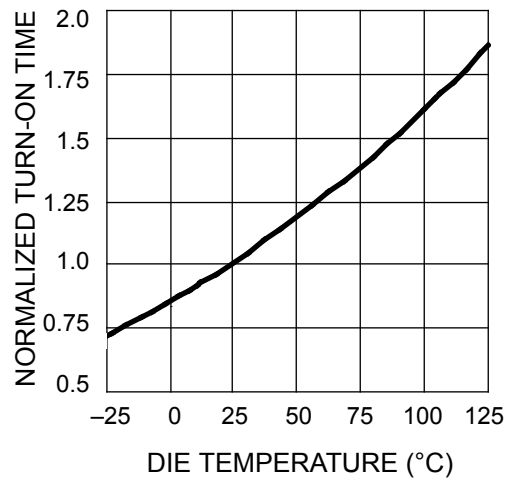

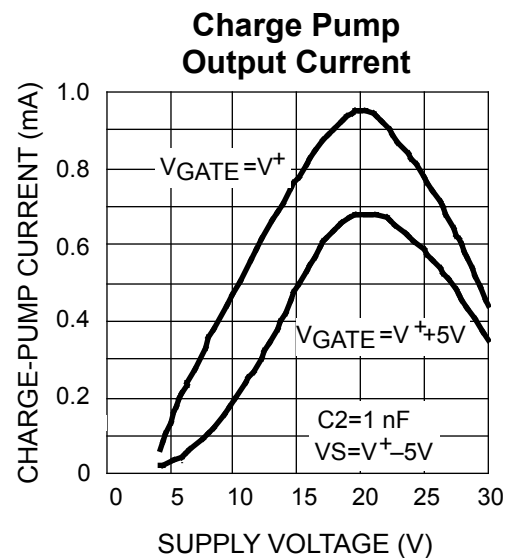
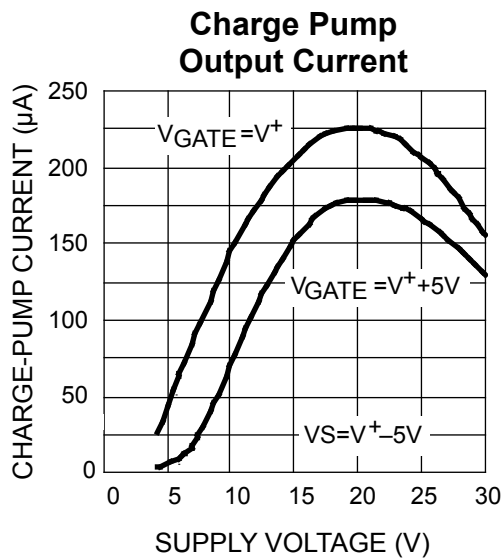

Block Diagram

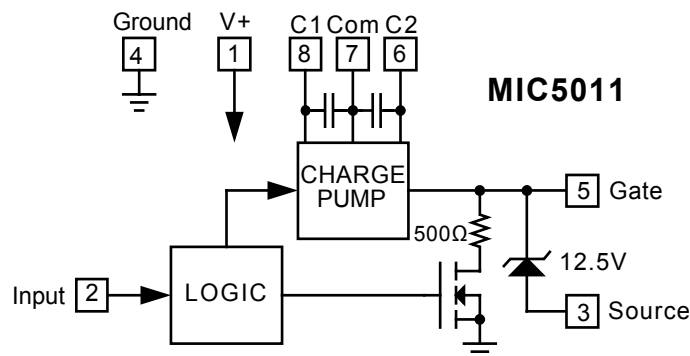

Applications Information

Functional Description (Refer to Block Diagram)

The MIC5011 functions are controlled via a logic block connected to the input pin 2. When the input is low, all functions are turned off for low standby current and the gate of the power MOSFET is also held low through 500 Ω to an N-channel switch. When the input is taken above the turn-on threshold (3.5V typical), the N-channel switch turns off and the charge pump is turned on to charge the gate of the power FET.

The charge pump incorporates a 100kHz oscillator and on-chip pump capacitors capable of charging 1nF to 5V above supply in 60 μs typical. With the addition of 1nF capacitors at C1 and C2, the turn-on time is reduced to 25 μs typical (see Figure 3). The charge pump is capable of pumping the gate up to over twice the supply voltage. For this reason, a zener clamp (12.5V typical) is provided between the gate pin 5 and source pin 3 to prevent exceeding the V_{GS} rating of the MOSFET at high supplies.

Applications Information (Continued)

Construction Hints

High current pulse circuits demand equipment and assembly techniques that are more stringent than normal, low current lab practices. The following are the sources of pitfalls most often encountered during prototyping. *Supplies:* many bench power supplies have poor transient response. Circuits that are being pulse tested, or those that operate by pulse-width modulation will produce strange results when used with a supply that has poor ripple rejection, or a peaked transient response. Always monitor the power supply voltage that appears at the drain of a high-side driver (or the supply side of the load in a low-side driver) with an oscilloscope. It is not uncommon to find bench power supplies in the 1 kW class that overshoot or undershoot by as much as 50% when pulse loaded. Not only will the load current and voltage measurements be affected, but it is possible to over-stress various components—especially electrolytic capacitors—with possibly catastrophic results. A 10 μ F supply bypass capacitor at the chip is recommended.

Residual Resistances: Resistances in circuit connections may also cause confusing results. For example, a circuit may employ a 50m Ω power MOSFET for low drop, but careless construction techniques could easily add 50 to 100m Ω resistance. Do not use a socket for the MOSFET. If the MOSFET is a TO-220 type package, make high-current drain connections to the tab. Wiring losses have a profound effect on high-current circuits. A floating millivoltmeter can identify connections that are contributing excess drop under load.

Circuit Topologies

The MIC5011 is suited for use with standard MOSFETs in high- or low-side driver applications. In addition, the MIC5011 works well in applications where, for faster switching times, the supply is bootstrapped from the MOSFET source output. Low voltage, high-side drivers (such as shown in Figure 1) are the slowest; their speed is reflected in the gate turn-on time specifications. The fastest drivers are the low-side and bootstrapped high-side types (Figures 2 and 4). Load current switching times are often much faster than the time to full gate enhancement, depending on the circuit type, the MOSFET, and the load. Turn-off times are essentially the same for all circuits (less than 10 μ s to $V_{GS} = 1V$). The choice of one topology over another is based on a combination of considerations including speed, voltage, and desired system characteristics.

High-Side Driver (Figure 1). The high-side topology works well down to $V^+ = 7V$ with standard MOSFETs. From 4.75 to 7V supply, a logic-level MOSFET can be substituted since the MIC5011 will not reach 10V gate enhancement (10V is the maximum rating for logic-compatible MOSFETs).

High-side drivers implemented with MIC501X drivers are self-protected against inductive switching transients. During turn-off an inductive load will force the MOSFET source 5V or more below ground, while the MIC5011 holds the gate at ground potential. The MOSFET is forced into conduction,

and it dissipates the energy stored in the load inductance. The MIC5011 source pin (3) is designed to withstand this negative excursion without damage. External clamp diodes are unnecessary.

Low-Side Driver (Figure 2). A key advantage of the low-side topology is that the load supply is limited only by the MOSFET BVDS rating. Clamping may be required to protect the MOSFET drain terminal from inductive switching transients. The MIC5011 supply should be limited to 15V in low-side topologies, otherwise a large current will be forced through the gate clamp zener.

Low-side drivers constructed with the MIC501X family are also fast; the MOSFET gate is driven to near supply immediately when commanded ON. Typical circuits achieve 10V enhancement in 10 μ s or less on a 12 to 15V supply.

Modifying Switching Times (Figure 3). High-side switching times can be improved by a factor of 2 or more by adding external charge pump capacitors of 1nF each. In cost-sensitive applications, omit C1 (C2 has a dominant effect on speed).

Do not add external capacitors to the MOSFET gate. Add a resistor (1k Ω to 51k Ω) in series with the gate to slow down the switching time.

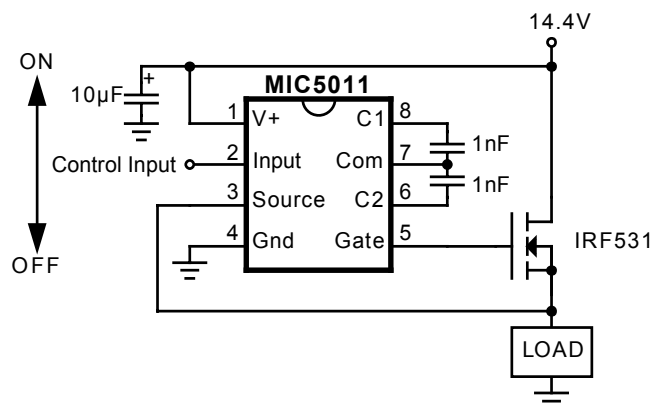

Figure 3. High Side Driver with External Charge Pump Capacitors

Bootstrapped High-Side Driver (Figure 4). The speed of a high-side driver can be increased to better than 10 μ s by bootstrapping the supply off of the MOSFET source. This topology can be used where the load is pulse-width modulated (100Hz to 20kHz), or where it is energized continuously. The Schottky barrier diode prevents the MIC5011 supply pin from dropping more than 200mV below the drain supply, and it also improves turn-on time on supplies of less than 10V. Since the supply current in the “off” state is only a small leakage, the 100nF bypass capacitor tends to remain charged for several seconds after the MIC5011 is turned off. In a PWM application the chip supply is sustained at a higher potential than the system supply, which improves switching time.

Applications Information (Continued)

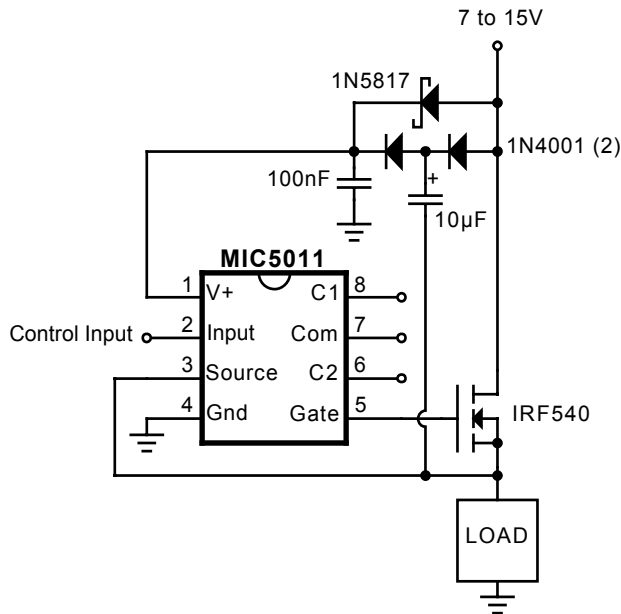

Figure 4. Bootstrapped High-Side Driver

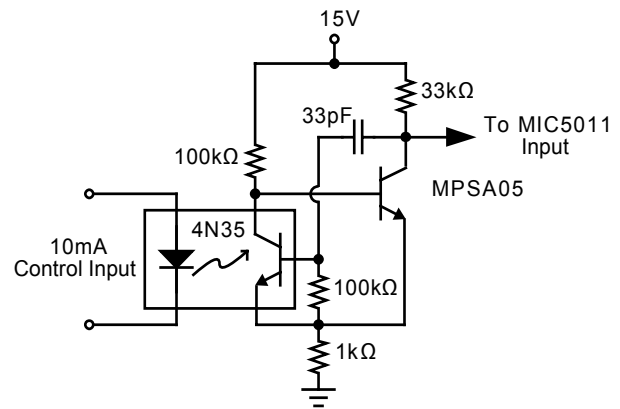

Figure 5. Improved Opto-Isolator Performance

Opto-Isolated Interface (Figure 5). Although the MIC5011 has no special input slew rate requirement, the lethargic transitions provided by an opto-isolator may cause oscillations on the rise and fall of the output. The circuit shown accelerates the input transitions from a 4N35 opto-isolator by adding hysteresis. Opto-isolators are used where the control circuitry cannot share a common ground with the MIC5011 and high-current power supply, or where the control circuitry is located remotely. This implementation is intrinsically safe; if the control line is severed the MIC5011 will turn OFF.

Industrial Switch (Figure 6). The most common manual control for industrial loads is a push button on/off switch. The “on” button is physically arranged in a recess so that in a panic situation the “off” button, which extends out from the control box, is more easily pressed. This circuit is

compatible with control boxes such as the CR2943 series (GE). The circuit is configured so that if both switches close simultaneously, the “off” button has precedence.

This application also illustrates how two (or more) MOSFETs can be paralleled. This reduces the switch drop, and distributes the switch dissipation into multiple packages.

High-Voltage Bootstrap (Figure 7). Although the MIC5011 is limited to operation on 4.75 to 32V supplies, a floating bootstrap arrangement can be used to build a high-side switch that operates on much higher voltages. The MIC5011 and MOSFET are configured as a low-side driver, but the load is connected in series with ground.

Power for the MIC5011 is supplied by a charge pump. A 20kHz square wave (15Vp-p) drives the pump capacitor and delivers current to a 100µF storage capacitor. A zener

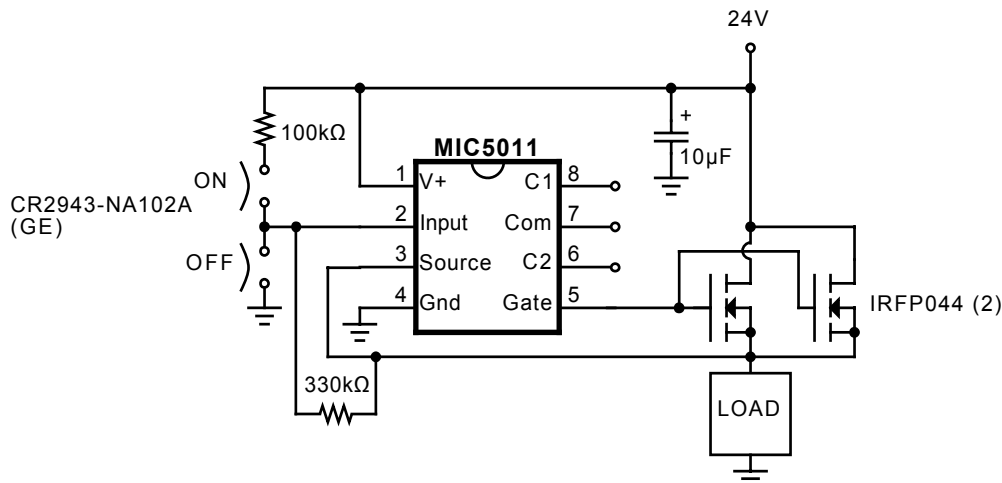

Figure 6. 50-Ampere Industrial Switch

Applications Information (Continued)

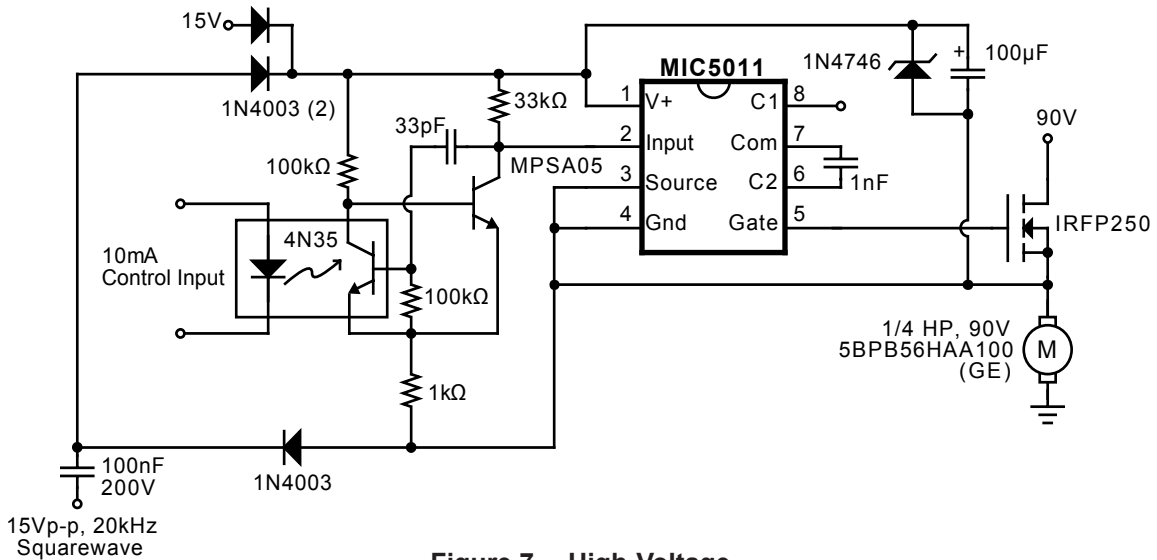

Figure 7. High-Voltage Bootstrapped Driver

diode limits the supply to 18V. When the MIC5011 is off, power is supplied by a diode connected to a 15V supply. The circuit of Figure 5 is put to good use as a barrier between low voltage control circuitry and the 90V motor supply.

Half-Bridge Motor Driver (Figure 8). Closed loop control of motor speed requires a half-bridge driver. This topology presents an extra challenge since the two output devices should not cross conduct (shoot-through) when switching.

Cross conduction increases output device power dissipation. Speed is also important, since PWM control requires the outputs to switch in the 2 to 20kHz range.

The circuit of Figure 8 utilizes fast configurations for both the top- and bottom-side drivers. Delay networks at each input provide a 2 to 3μs dead time effectively eliminating cross conduction. Two of these circuits can be connected together to form an H-bridge for locked antiphase or sign/magnitude control.

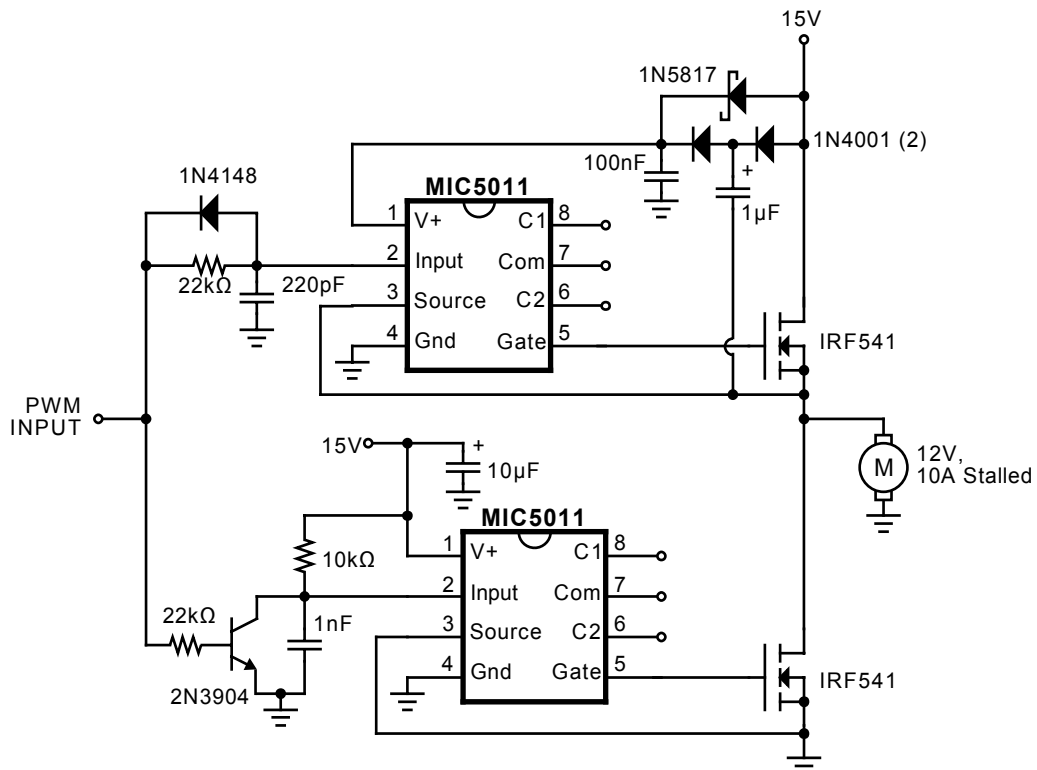

Figure 8. Half-Bridge Motor Driver

Applications Information (Continued)

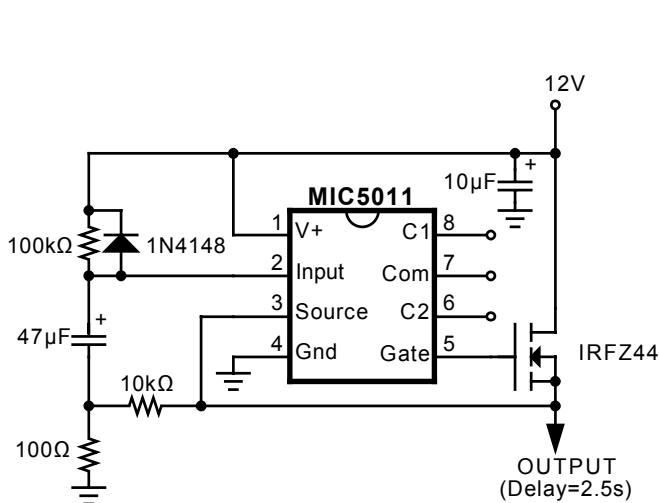

Figure 9. 30-Ampere Time-Delay Relay

Time-Delay Relay (Figure 9). The MIC5011 forms the basis of a simple time-delay relay. As shown, the delay commences when power is applied, but the 100kΩ/1N4148 could be independently driven from an external source such as a switch or another high-side driver to give a delay relative to some other event in the system. Hysteresis has been added to guarantee clean switching at turn-on.

Motor Driver with Stall Shutdown (Figure 10). Tachometer feedback can be used to shut down a motor driver circuit when a stall condition occurs. The control switch is a 3-way type; the “START” position is momentary and forces the driver ON. When released, the switch returns to the “RUN” position, and the tachometer’s output is used to hold the MIC5011 input ON. If the motor slows down, the tach output is reduced, and the MIC5011 switches OFF. Resistor “R” sets the shutdown threshold.

Electronic Governor (Figure 11). The output of an ac tachometer can be used to form a PWM loop to maintain the speed of a motor. The tachometer output is rectified, partially filtered, and fed back to the input of the MIC5011. When the motor is stalled there is no tachometer output, and MIC5011 input is pulled high delivering full power to the motor. If the motor spins fast enough, the tachometer output is sufficient to pull the MIC5011 input low, shutting the output off. Since the rectified waveform is only partially filtered, the input oscillates around its threshold causing the MIC5011 to switch on and off at the frequency of the tachometer signal. A PWM action results since the average dc voltage at the input decreases as the motor spins faster. The 1kΩ potentiometer is used to set the running speed of the motor. Loop gain (and speed regulation) is increased by increasing the value of the 100nF filter capacitor.

The performance of such a loop is imprecise, but stable and inexpensive. A more elaborate loop would consist of a PWM controller and a half-bridge.

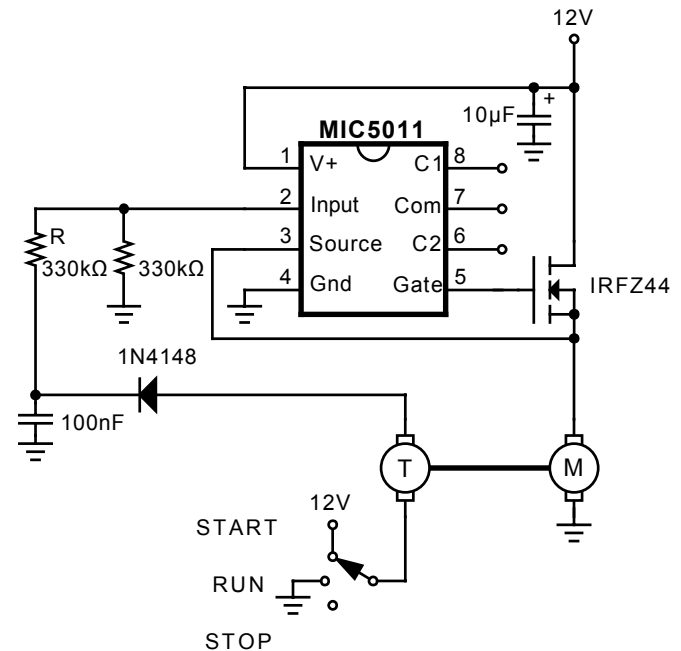

Figure 10. Motor Stall Shutdown

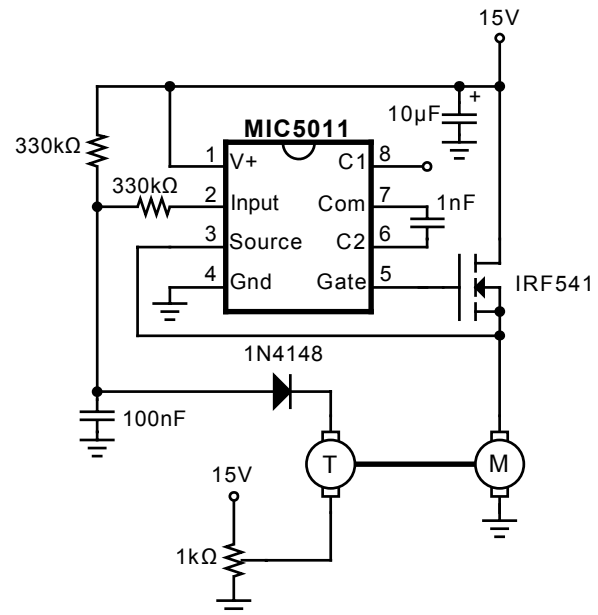

Figure 11. Electronic Governor

Applications Information (Continued)

Gate Control Circuit

When applying the MIC5011, it is helpful to understand the operation of the gate control circuitry (see Figure 12). The gate circuitry can be divided into two sections: 1) charge pump (oscillator, Q1-Q5, and the capacitors) and 2) gate turn-off switch (Q6).

When the MIC5011 is in the OFF state, the oscillator is turned off, thereby disabling the charge pump. Q5 is also turned off, and Q6 is turned on. Q6 holds the gate pin (G) at ground potential which effectively turns the external MOSFET off.

Q6 is turned off when the MIC5011 is commanded on, and Q5 pulls the gate up to supply (through 2 diodes). Next, the charge pump begins supplying current to the gate. The gate accepts charge until the gate-source voltage reaches 12.5V and is clamped by the zener diode.

A 2-output, three-phase clock switches Q1-Q4, providing a quasi-tripling action. During the initial phase Q4 and Q2 are

ON. C1 is discharged, and C2 is charged to supply through Q5. For the second phase Q4 turns off and Q3 turns on, pushing pin C2 above supply (charge is dumped into the gate). Q3 also charges C1. On the third phase Q2 turns off and Q1 turns on, pushing the common point of the two capacitors above supply. Some of the charge in C1 makes its way to the gate. The sequence is repeated by turning Q2 and Q4 back on, and Q1 and Q3 off.

In a low-side application operating on a 12 to 15V supply, the MOSFET is fully enhanced by the action of Q5 alone. On supplies of more than approximately 14V, current flows directly from Q5 through the zener diode to ground. To prevent excessive current flow, the MIC5011 supply should be limited to 15V in low-side applications.

The action of Q5 makes the MIC5011 operate quickly in low-side applications. In high-side applications Q5 pre-charges the MOSFET gate to supply, leaving the charge pump to carry the gate up to full enhancement 10V above supply. Bootstrapped high-side drivers are as fast as low-side drivers since the chip supply is boosted well above the drain at turn-on.

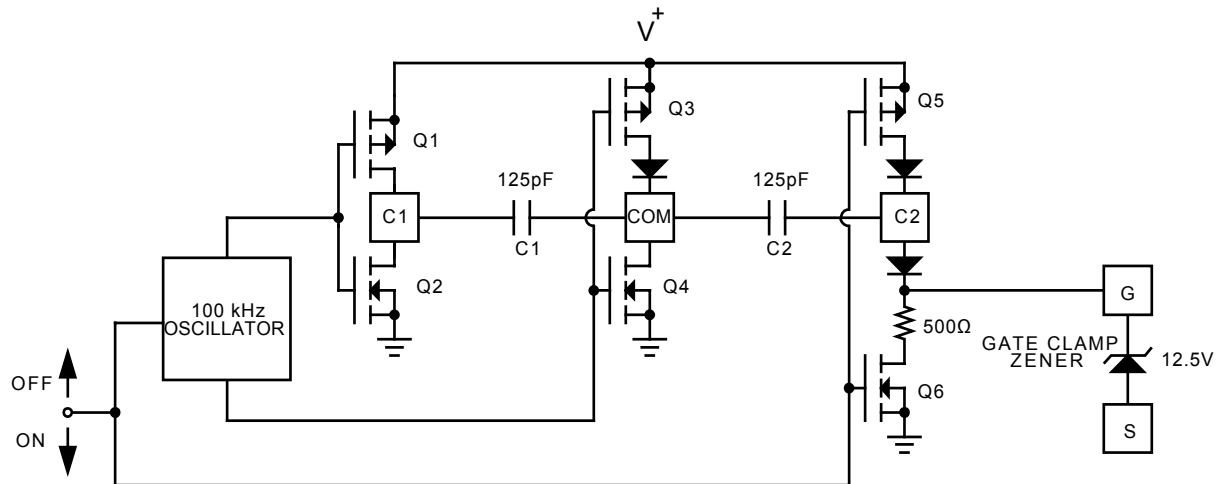
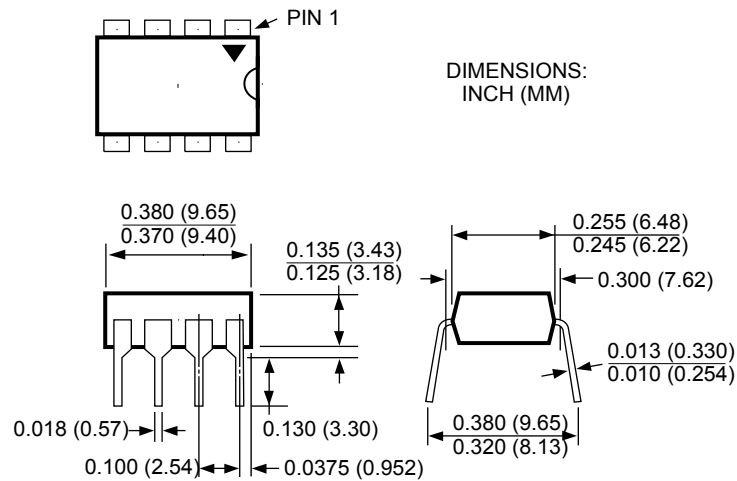
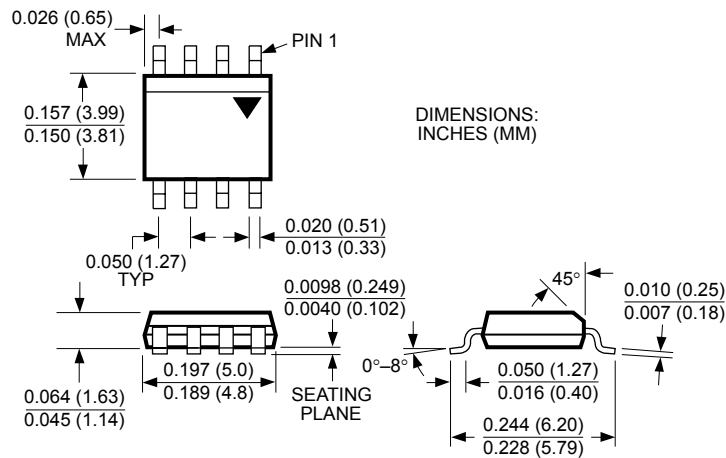

Figure 12. Gate Control Circuit Detail

Package Information



8-Pin Plastic DIP (N)



8-Pin SOIC (M)

MICREL INC. 2180 FORTUNE DRIVE SAN JOSE, CA 95131 USA

TEL + 1 (408) 944-0800 FAX + 1 (408) 474-1000 WEB <http://www.micrel.com>

This information furnished by Micrel in this data sheet is believed to be accurate and reliable. However no responsibility is assumed by Micrel for its use. Micrel reserves the right to change circuitry and specifications at any time without notification to the customer.

Micrel Products are not designed or authorized for use as components in life support appliances, devices or systems where malfunction of a product can reasonably be expected to result in personal injury. Life support devices or systems are devices or systems that (a) are intended for surgical implant into the body or (b) support or sustain life, and whose failure to perform can be reasonably expected to result in a significant injury to the user. A Purchaser's use or sale of Micrel Products for use in life support appliances, devices or systems is a Purchaser's own risk and Purchaser agrees to fully indemnify Micrel for any damages resulting from such use or sale.

© 1998 Micrel, Inc.

Mouser Electronics

Authorized Distributor

Click to View Pricing, Inventory, Delivery & Lifecycle Information:

[Microchip:](#)

[MIC5011YN](#) [MIC5011YM TR](#) [MIC5011YM](#) [MIC5011YM-TR](#)