

# TLV61048 14-V Output Voltage Non-synchronous Boost Converter in SOT-23 package

## 1 Features

- Input voltage 2.65 V to 5.5 V (falling 2.4 V)
- Output voltage up to 14 V
- Integrated low-side FET: 85 mΩ at 3.3 V<sub>IN</sub>
- 3.7-A (Typical) switch current limit
- Up to 90% Efficiency at 3.3-V Input and 12-V Output
- 600-kHz or 1-MHz Selectable switching frequency
- Internal Compensation
- 1-μA Shutdown current
- ±2.5% Output-voltage accuracy
- PFM operation mode at light load
- Internal 2-ms soft-start time
- Thermal shutdown protection
- 2.9-mm × 1.6-mm 6-Pin SOT-23 package

## 2 Applications

- PLC backup power
- LCD bias supply
- Industrial isolation DC/DC

## 3 Description

The TLV61048 is a non-synchronous boost converter that provides a power-supply solution for products powered by a low-voltage super capacitor and a single-cell Li-ion battery. The TLV61048 integrates a power switch with 3.7-A typical current limit to extend the discharge capability of the input source without sacrificing maximal load delivery.

The TLV61048 could be configured at 600 kHz for higher efficiency or 1 MHz for smaller inductor and output capacitor. At the light load, the device enters into the PFM operation to achieve higher efficiency. The TLV61048 has built-in 2-ms soft start to minimize the inrush current.

The TLV61048 is available in a 2.9-mm × 1.6-mm 6-pin SOT-23 package.

### Device Information<sup>(1)</sup>

| PART NUMBER | PACKAGE    | BODY SIZE (NOM)   |
|-------------|------------|-------------------|
| TLV61048    | SOT-23 (6) | 2.90 mm × 1.60 mm |

(1) For all available packages, see the orderable addendum at the end of the data sheet.

### Simplified Schematic

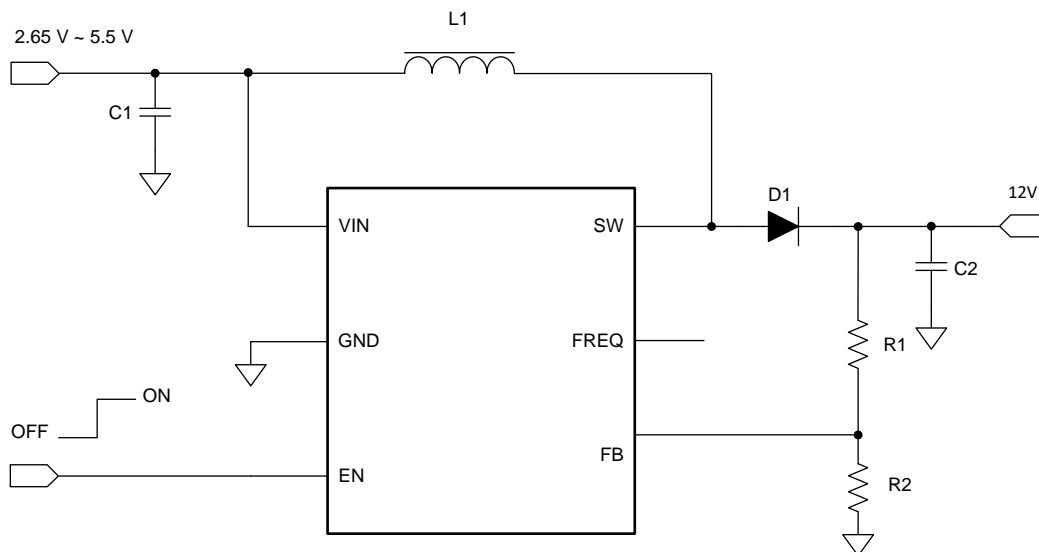

## Table of Contents

|  |          |  |           |
|--|----------|--|-----------|
| <b>1 Features</b> .....                        | <b>1</b> | 7.4 Device Functional Modes.....                                 | <b>8</b>  |
| <b>2 Applications</b> .....                    | <b>1</b> | <b>8 Application and Implementation</b> .....                    | <b>10</b> |
| <b>3 Description</b> .....                     | <b>1</b> | 8.1 Application Information.....                                 | <b>10</b> |
| <b>4 Revision History</b> .....                | <b>2</b> | 8.2 Typical Applications .....                                   | <b>10</b> |
| <b>5 Pin Configuration and Functions</b> ..... | <b>3</b> | <b>9 Power Supply Recommendations</b> .....                      | <b>15</b> |
| <b>6 Specifications</b> .....                  | <b>4</b> | <b>10 Layout</b> .....   | <b>15</b> |
| 6.1 Absolute Maximum Ratings .....             | <b>4</b> | 10.1 Layout Guidelines .....                                     | <b>15</b> |
| 6.2 ESD Ratings .....                          | <b>4</b> | 10.2 Layout Example .....  | <b>15</b> |
| 6.3 Recommended Operating Conditions.....      | <b>4</b> | <b>11 Device and Documentation Support</b> .....                 | <b>16</b> |
| 6.4 Thermal Information .....                  | <b>4</b> | 11.1 Device Support .....  | <b>16</b> |
| 6.5 Electrical Characteristics.....            | <b>5</b> | 11.2 Receiving Notification of Documentation Updates             | <b>16</b> |
| 6.6 Typical Characteristics.....               | <b>6</b> | 11.3 Community Resources.....                                    | <b>16</b> |
| <b>7 Detailed Description</b> .....            | <b>7</b> | 11.4 Trademarks .....  | <b>16</b> |
| 7.1 Overview .....                             | <b>7</b> | 11.5 Electrostatic Discharge Caution.....                        | <b>16</b> |
| 7.2 Functional Block Diagram .....             | <b>7</b> | 11.6 Glossary .....  | <b>16</b> |
| 7.3 Feature Description.....                   | <b>7</b> | <b>12 Mechanical, Packaging, and Orderable Information</b> ..... | <b>16</b> |

## 4 Revision History

NOTE: Page numbers for previous revisions may differ from page numbers in the current version.

### Changes from Original (March 2019) to Revision A

Page

|  |          |
|--|----------|
| • Changed to production data release with typical characteristics curves. .... | <b>1</b> |
|--|----------|

## 5 Pin Configuration and Functions

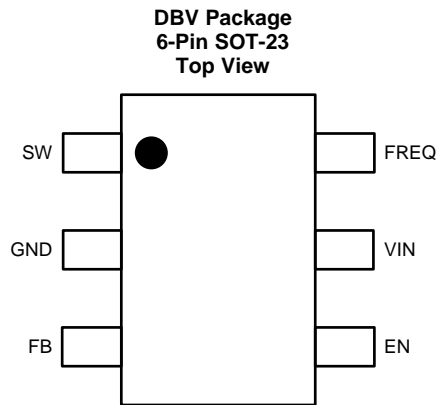

### Pin Functions

| PIN |      | I/O | DESCRIPTION   |
|-----|------|-----|---|
| NO. | NAME |     |   |
| 1   | SW   | PWR | The switch pin of the converter. It is connected to the drain of the internal power MOSFET.                                       |
| 2   | GND  | PWR | Ground  |
| 3   | FB   | I   | Voltage feedback of output voltage. Connected to the center tap of a resistor divider to program the output voltage.              |
| 4   | EN   | I   | Enable logic input. Logic high voltage enables the device. Logic low voltage disables the device and turns it into shutdown mode. |
| 5   | VIN  | I   | IC power supply input   |
| 6   | FREQ | I   | Frequency select pin. The device operates at 600 kHz if FREQ is left floating or pulled high and at 1 MHz if connected to GND.    |

## 6 Specifications

### 6.1 Absolute Maximum Ratings

over operating free-air temperature range (unless otherwise noted) <sup>(1)</sup>

|  |               | MIN  | MAX | UNIT |
|--|---------------|------|-----|------|
| Voltage range at terminals <sup>(2)</sup>            | VIN, EN, FREQ | -0.3 | 6   | V    |
|  | SW            | -0.3 | 18  | V    |
|  | FB            | -0.3 | 3.6 | V    |
| Operating junction temperature range, T <sub>J</sub> |               | -40  | 150 | °C   |

- (1) Stresses beyond those listed under *Absolute Maximum Ratings* may cause permanent damage to the device. These are stress ratings only, which do not imply functional operation of the device at these or any other conditions beyond those indicated under *Recommended Operating Conditions*. Exposure to absolute-maximum-rated conditions for extended periods may affect device reliability.
- (2) All voltage values are with respect to network ground terminal.

### 6.2 ESD Ratings

|                                   |                         |  | VALUE | UNIT |
|-----------------------------------|-------------------------|--|-------|------|
| V <sub>(ESD)</sub> <sup>(1)</sup> | Electrostatic discharge | Human body model (HBM), per ANSI/ESDA/JEDEC JS-001, all pins <sup>(2)</sup>              | ±2000 | V    |
|                                   |                         | Charged device model (CDM), per JEDEC specification JESD22-C101, all pins <sup>(3)</sup> | ±500  | V    |

- (1) Electrostatic discharge (ESD) to measure device sensitivity and immunity to damage caused by assembly line electrostatic discharges in to the device.
- (2) JEDEC document JEP155 states that 500-V HBM allows safe manufacturing with a standard ESD control process.
- (3) JEDEC document JEP157 states that 250-V CDM allows safe manufacturing with a standard ESD control process.

### 6.3 Recommended Operating Conditions

over operating free-air temperature range (unless otherwise noted)

|                  |                                    | MIN  | TYP | MAX | UNIT |
|------------------|------------------------------------|------|-----|-----|------|
| V <sub>IN</sub>  | Input voltage range                | 2.65 |     | 5.5 | V    |
| V <sub>OUT</sub> | Output voltage range               | 3.3  |     | 14  | V    |
| L                | Effective inductance range         | 2.2  | 4.7 | 10  | μH   |
| C <sub>IN</sub>  | Effective input capacitance range  | 0.22 | 1   |     | μF   |
| C <sub>OUT</sub> | Effective output capacitance range | 3    |     |     | μF   |
| T <sub>J</sub>   | Operating junction temperature     | -40  |     | 125 | °C   |

### 6.4 Thermal Information

| THERMAL METRIC <sup>(1)</sup> |  | TLV61048    | UNIT |
|-------------------------------|--|-------------|------|
|                               |  | DBV (SOT23) |      |
|                               |  | 6 PINS      |      |
| R <sub>θJA</sub>              | Junction-to-ambient thermal resistance       | 177.7       | °C/W |
| R <sub>θJC(top)</sub>         | Junction-to-case (top) thermal resistance    | 120.6       | °C/W |
| R <sub>θJB</sub>              | Junction-to-board thermal resistance         | 33.2        | °C/W |
| ψ <sub>JT</sub>               | Junction-to-top characterization parameter   | 21.5        | °C/W |
| ψ <sub>JB</sub>               | Junction-to-board characterization parameter | 32.6        | °C/W |
| R <sub>θJC(bot)</sub>         | Junction-to-case (bottom) thermal resistance | n/a         | °C/W |

- (1) For more information about traditional and new thermal metrics, see the [Semiconductor and IC package thermal metrics application report](#).

## 6.5 Electrical Characteristics

$T_A = -40^{\circ}\text{C}$  to  $85^{\circ}\text{C}$ ,  $V_{IN} = 3.3\text{ V}$ . Typical values are at  $T_A = 25^{\circ}\text{C}$ , unless otherwise noted.

| PARAMETER              |                                 | TEST CONDITIONS   | MIN  | TYP  | MAX  | UNIT               |
|------------------------|---------------------------------|---|------|------|------|--------------------|
| <b>POWER SUPPLY</b>    |                                 |   |      |      |      |                    |
| $V_{IN}$               | Input voltage range             |   | 2.65 |      | 5.5  | V                  |
| $V_{IN\_UVLO}$         | Under voltage lockout threshold | $V_{IN}$ rising   |      | 2.55 | 2.65 | V                  |
|                        |                                 | $V_{IN}$ falling  | 2.3  | 2.4  |      |                    |
| $V_{IN\_HYS}$          | VIN UVLO hysteresis             |   |      | 150  |      | mV                 |
| $I_{Q\_VIN}$           | Quiescent current into VIN pin  | IC enabled, no load, no switching   |      | 100  |      | $\mu\text{A}$      |
| $I_{SD}$               | Shutdown current into VIN pin   | IC disabled, $V_{IN} = 2.6\text{ V}$ to $5.5\text{ V}$ , $T_A = 25^{\circ}\text{C}$ |      |      | 1.0  | $\mu\text{A}$      |
| <b>OUTPUT</b>          |                                 |   |      |      |      |                    |
| $V_{OUT}$              | Output voltage range            |   | 3.3  |      | 14   | V                  |
| $V_{REF}$              | Feedback voltage                | PWM mode, $T_A = -40^{\circ}\text{C}$ to $125^{\circ}\text{C}$                      | 0.78 | 0.8  | 0.82 | V                  |
|                        |                                 | PFM mode, $T_A = 25^{\circ}\text{C}$  |      | 0.81 |      | V                  |
| $I_{FB\_LKG}$          | Leakage current into FB pin     | $T_A = 25^{\circ}\text{C}$  |      |      | 50   | nA                 |
| $I_{SW\_LKG}$          | Leakage current into SW pin     | IC disabled, $SW = 5.5\text{V}$   |      |      | 500  | nA                 |
| <b>POWER SWITCH</b>    |                                 |   |      |      |      |                    |
| $R_{DS(on)}$           | Low-side MOSFET on resistance   | $V_{IN} = 3.3$ , $V_{OUT} = 12\text{V}$   |      | 85   |      | m $\Omega$         |
| $f_{SW}$               | Switching frequency             | $V_{IN} = 3.3\text{ V}$ , $V_{OUT} = 12\text{ V}$ , PWM mode                        | 430  | 550  | 630  | kHz                |
|                        |                                 | $V_{IN} = 3.3\text{ V}$ , $V_{OUT} = 12\text{ V}$ , PFM mode                        | 850  | 1000 | 1250 |                    |
| $t_{OFF\_min}$         | Min. off time                   |   |      | 130  |      | ns                 |
| $I_{LIM\_SW}$          | Peak switch current limit       | 600kHz, $V_{IN} = 3.3\text{V}$  | 2.9  | 3.7  | 4.5  | A                  |
| $t_{STARTUP}$          | Startup time                    |   |      | 2    |      | ms                 |
| <b>LOGIC INTERFACE</b> |                                 |   |      |      |      |                    |
| $V_{EN\_H}$            | EN Logic high threshold         |   |      |      | 1.2  | V                  |
| $V_{EN\_L}$            | EN Logic low threshold          |   | 0.4  |      |      | V                  |
| $R_{EN}$               | EN Pull Down Resistor           |   |      | 1    |      | M $\Omega$         |
| $R_{FREQ}$             | FREQ pull up resistance         |   |      | 950  |      | k $\Omega$         |
| $V_{FREQ\_H}$          | FREQ logic high threshold       |   |      |      | 1.2  | V                  |
| $V_{FREQ\_L}$          | FREQ logic low threshold        |   | 0.4  |      |      | V                  |
| <b>PROTECTION</b>      |                                 |   |      |      |      |                    |
| $T_{SD}$               | Thermal shutdown threshold      | $T_J$ rising  |      | 150  |      | $^{\circ}\text{C}$ |
| $T_{SD\_HYS}$          | Thermal shutdown hysteresis     | $T_J$ falling below $T_{SD}$  |      | 20   |      | $^{\circ}\text{C}$ |

### 6.6 Typical Characteristics

$V_{IN} = 3.3\text{ V}$ ,  $V_{OUT} = 12\text{ V}$ ,  $T_A = 25^\circ\text{C}$ , unless otherwise noted

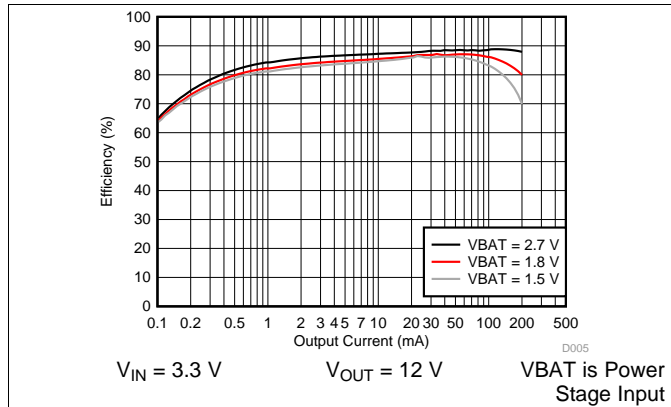

Figure 1. Efficiency vs Output Current

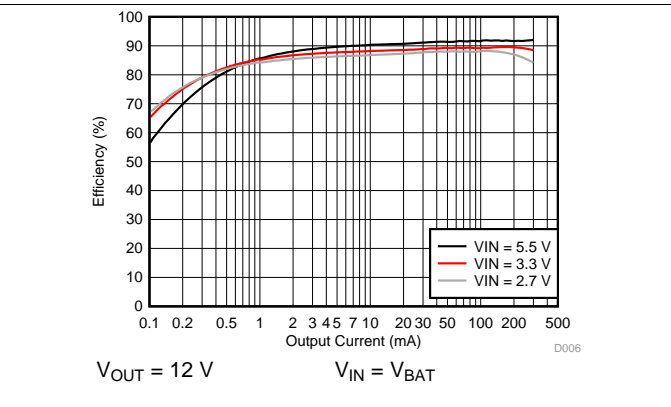

Figure 2. Efficiency vs Output Current

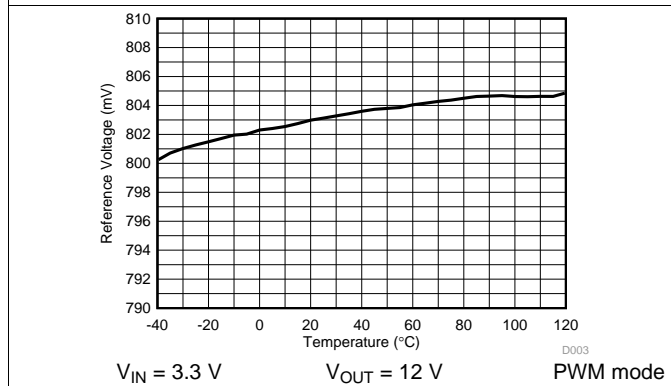

Figure 3. FB Reference Voltage vs Temperature

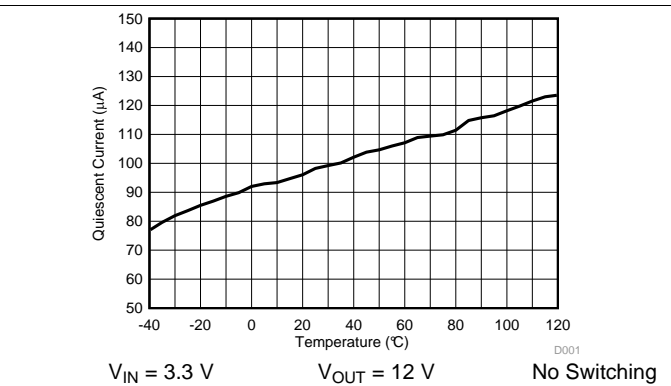

Figure 4. Quiescent Current into VIN vs Temperature

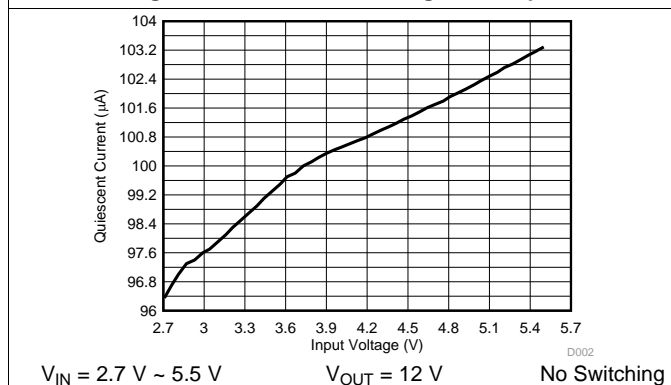

Figure 5. Quiescent Current into VIN vs Input Voltage

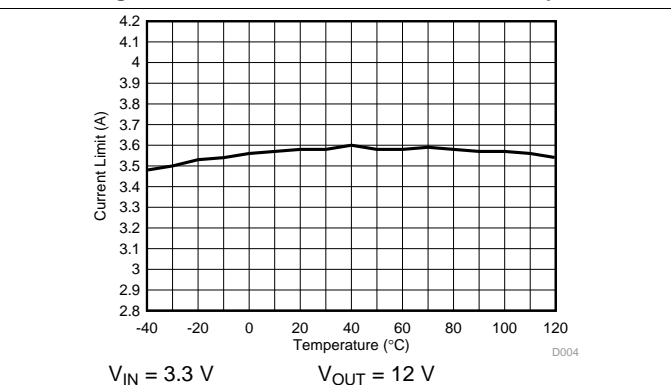

Figure 6. Current Limit vs Temperature

## 7 Detailed Description

### 7.1 Overview

The TLV61048 is a non-synchronous boost converter supporting output voltage up to 14 V with input ranging from 2.65 V to 5.5 V. The TLV61048 integrates a power switch with current limit up to 3.7 A (typical). The device operates in a current mode scheme with quasi-constant frequency with internal loop compensation built in. The switching frequency is selectable between 600 kHz and 1 MHz. There is internal fixed soft start time which is 2 ms typically to control the inrush current during startup.

Topology of the TLV61048 boost converter is adaptive off-time with peak current control, which provides superior load and line transient responses. The selectable switching frequency offers the possibility to optimize the design either for the use of small sized inductor (1 MHz) or for higher system efficiency (600 kHz).

The converter operates in continuous conduction mode (CCM) when the inductor valley current is above zero, while switches into discontinuous conduction mode (DCM) if valley current crossing zero. If the load is further lowered, the device enters into PFM operation to achieve even higher efficiency.

### 7.2 Functional Block Diagram

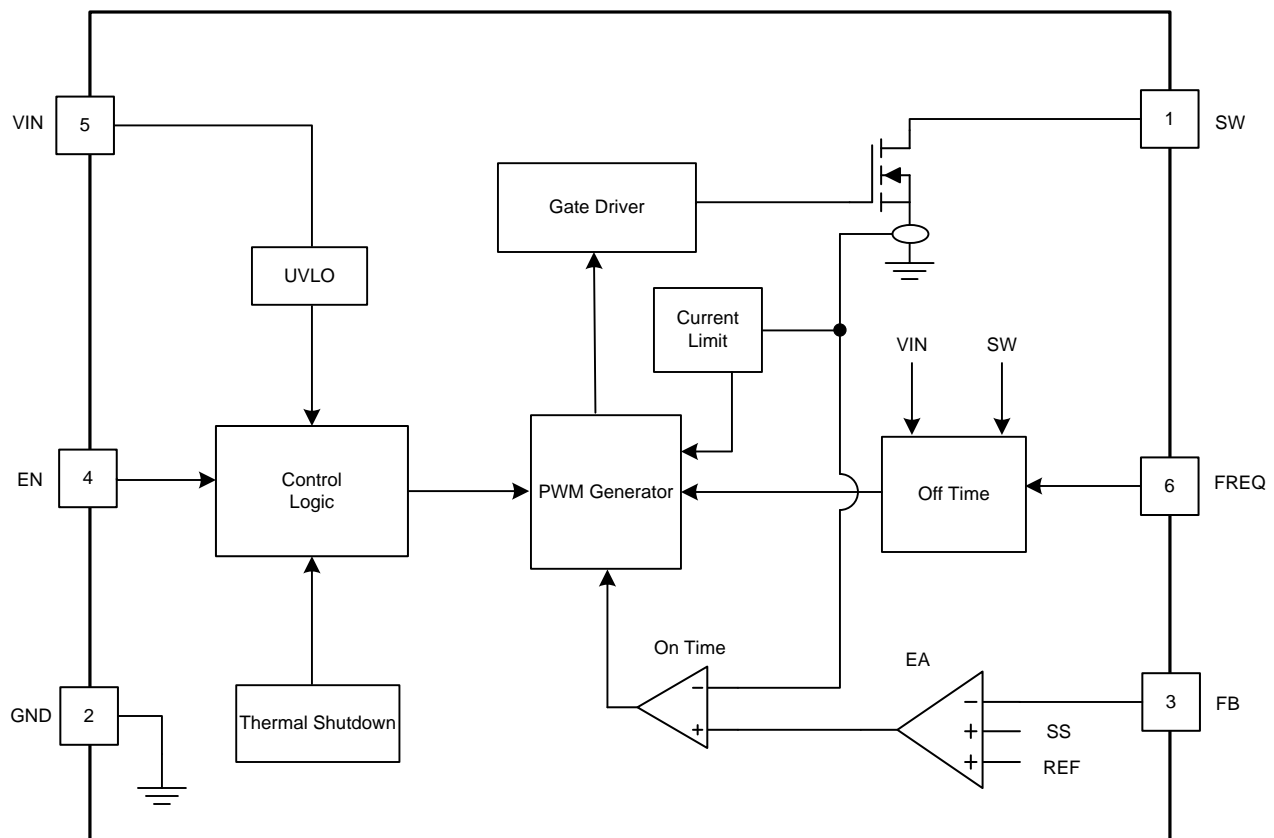

### 7.3 Feature Description

#### 7.3.1 Undervoltage Lockout

An undervoltage lockout (UVLO) circuit stops the operation of the converter when the input voltage drops below the typical UVLO falling threshold of 2.4 V. A hysteresis of 150 mV is added so that the device cannot be enabled again until the input voltage goes up to typical UVLO rising threshold of 2.55 V. This function is implemented in order to prevent malfunctioning of the device when the input voltage is between 2.4 V and 2.55 V.

## Feature Description (continued)

### 7.3.2 Enable and Disable

When the input voltage is above typical UVLO rising threshold of 2.55 V and the EN pin is pulled high, the TLV61048 is enabled. When the EN pin is pulled low, the TLV61048 stops the PWM switch and turns off the low side switch. The EN pin has an internal pull-down resistance of 1M $\Omega$ , the device is disabled when the EN pin is floating. In shutdown mode, less than 1- $\mu$ A input current is consumed.

### 7.3.3 Soft Start

The soft-start feature helps the regulator to gradually reach the steady state operating point, thus reducing start-up stresses and surge. When the input voltage is applied, the output capacitor is charged to VIN through the inductor and high side rectifier diode. After reaching the 2.55 V (typical) UVLO rising threshold, the internal soft-start control circuit initiates to ramp the reference voltage to 0.8 V within 2 ms (typical), while the low side FET starts switching after output capacitor is charged to the input voltage.

### 7.3.4 Frequency Select (FREQ)

The frequency select pin FREQ allows to set the switching frequency of the device to 600 kHz (FREQ = floating/high) or 1 MHz (FREQ = GND). Higher switching frequency improves load transient response but reduces efficiency slightly. The other benefit of higher switching frequency is lower output ripple voltage.

## 7.4 Device Functional Modes

The TLV61048 has two operation modes: PWM mode and PFM mode.

### 7.4.1 PWM Mode

The TLV61048 uses a quasi-constant frequency pulse width modulation (PWM) at moderate to heavy load currents. Based on the VIN/VOUTratio, a circuit predicts the required off-time. At the beginning of the switching cycle, the integrated NMOS switching FET, shown in the functional block diagram, is turned on. The input voltage is applied across the inductor and the inductor current ramps up. In this phase, the output capacitor is discharged by the load current. When the inductor current hits the current threshold that is set by the error amplifier output, the PWM switch is turned off, and the external power diode is forward-biased. The inductor transfers its stored energy to replenish the output capacitor and supply the load. When the off-time is expired, the next switching cycle starts again. The error amplifier compares the FB pin voltage with an internal reference, and its output determines the duty cycle of the PWM switching.

The TLV61048 has a built-in compensation circuit that can accommodate a wide range of input and output voltages for stable operation.

### 7.4.2 PFM Mode

The TLV61048 integrates a power save mode with pulse frequency modulation (PFM) to improve efficiency at light load. When the load current decreases, the inductor peak current set by the output of the error amplifier declines to regulate the output voltage. When the inductor peak current hits the low limit (400 mA typical), the output voltage exceeds the set threshold voltage as the load current decreases further. When the FB voltage hits the PFM reference voltage, the TLV61048 goes into power-save mode. In the power-save mode, the device only switches when the output voltage trips below a set threshold voltage. It ramps up the output with several pulses and enters the power save mode when the output voltage exceeds the set threshold voltage.



**Device Functional Modes (continued)**

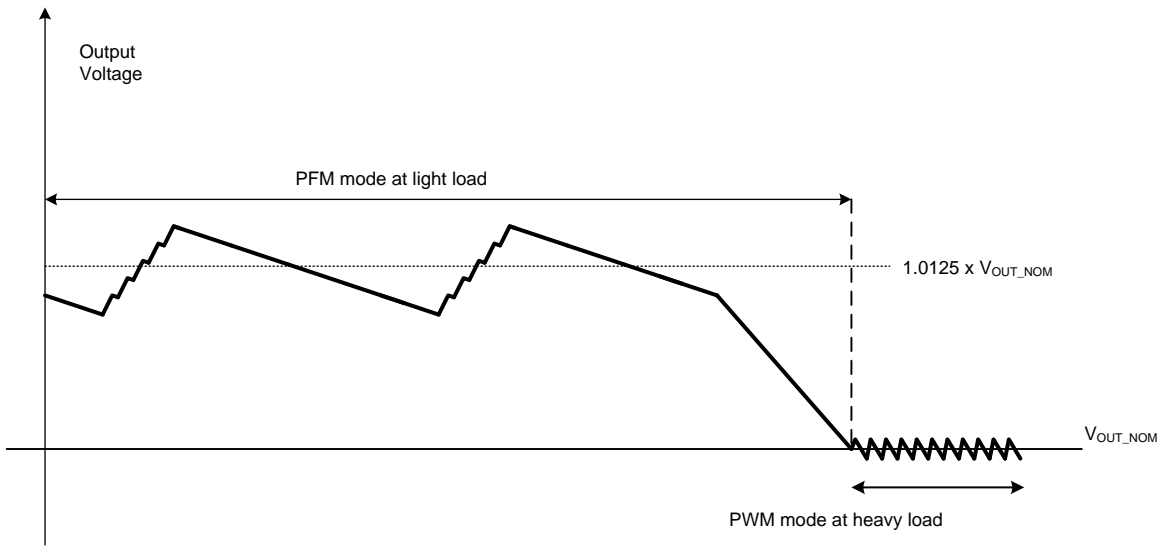

## 8 Application and Implementation

### NOTE

Information in the following applications sections is not part of the TI component specification, and TI does not warrant its accuracy or completeness. TI's customers are responsible for determining suitability of components for their purposes. Customers should validate and test their design implementation to confirm system functionality.

### 8.1 Application Information

TLV61048 is a boost DC/DC converter integrating a power switch and loop compensation circuits. The device has input range from 2.65 V to 5.5 V. The device can operate down to 1.5 V if an external 3.3-V bias supply is applied to the VIN pin. The TLV61048 adopts the current-mode control with adaptive constant off-time. The switching frequency is quasi-constant and selectable between 600 kHz and 1 MHz. The following design procedure can be used to select component values for the TLV61048.

### 8.2 Typical Applications

#### 8.2.1 12-V Output Boost Converter With External Bias

In this design example, TLV61048 VIN pin is supplied by an external 3.3-V bias voltage to keep internal circuitry on in order to extend power stage operating  $V_{IN}$  to 1.5 V. 600-kHz switching frequency is selected to reduce switching loss in order to improve overall efficiency.

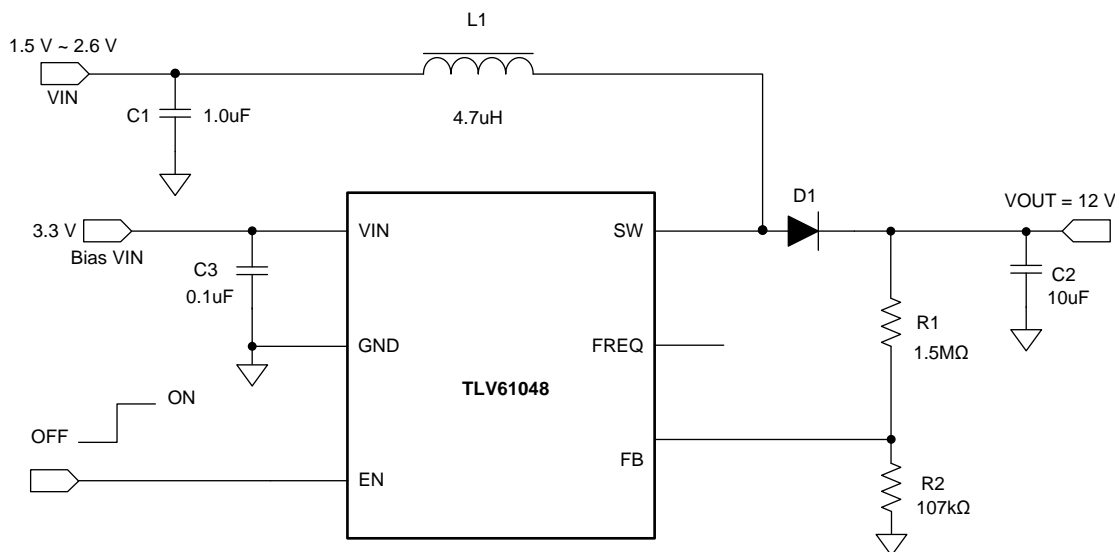

Figure 7. 12-V Boost Converter With External Bias

#### 8.2.1.1 Design Requirements

For this design example, see parameters are shown in Table 1:

Table 1. Design Requirements

| PARAMETERS            | VALUE          |
|-----------------------|----------------|
| Power input voltage   | 1.5 V to 2.6 V |
| Control input voltage | 3.3 V          |
| Output voltage        | 12 V           |
| Frequency             | 600 kHz        |
| Output current        | 0 - 200 mA     |

### 8.2.1.2 Detailed Design Procedure

#### 8.2.1.2.1 Programming the Output Voltage

Output voltage is programmed via external resistor divider. By selecting the external resistor divider R1 and R2, as shown in [Equation 1](#), the output voltage is programmed to the desired value. When the output voltage is regulated, the typical voltage at the FB pin is  $V_{REF}$  of 800 mV.

$$R1 = \left( \frac{V_{OUT}}{V_{REF}} - 1 \right) \times R2$$

where

- $V_{OUT}$  is the desired output voltage
  - $V_{REF}$  is the internal reference voltage at the FB pin
- (1)

For best accuracy, R2 should be kept smaller than 150 k $\Omega$  to ensure the current flowing through R2 is at least 100 times larger than the FB pin leakage current. Changing R2 towards a lower value increases the immunity against noise injection. Changing the R2 towards a higher value reduces the quiescent current for achieving higher efficiency at low load currents.

#### 8.2.1.2.2 Inductor Selection

Because the selection of the inductor affects steady state operation, transient behavior, and loop stability, the inductor is the most important component in power regulator design. There are three important inductor specifications, inductor value, saturation current, and DC resistance (DCR). The TLV61048 is designed to work with inductor values between 2.2  $\mu$ H and 10  $\mu$ H. Use [Equation 2](#) to [Equation 4](#) to calculate the peak current of the application inductor. To calculate the current in the worst case, use the minimum input voltage, maximum output voltage, and maximum load current of the application. To have enough design margin, choose the inductor value with  $-30\%$  tolerance, and a low power-conversion efficiency for the calculation. In a boost regulator, the inductor dc current can be calculated with [Equation 2](#).

$$I_{L(DC)} = \frac{V_{OUT} \times I_{OUT}}{V_{IN} \times \eta}$$

where

- $V_{OUT}$  = output voltage
  - $I_{OUT}$  = output current
  - $V_{IN}$  = input voltage
  - $\eta$  = power conversion efficiency, use 80% for most applications
- (2)

The inductor ripple current is calculated with the [Equation 3](#) for an asynchronous boost converter in continuous conduction mode (CCM).

$$\Delta I_{L(P-P)} = \frac{V_{IN} \times (V_{OUT} + 0.8V - V_{IN})}{L \times f_{SW} \times (V_{OUT} + 0.8V)}$$

where

- $\Delta I_{L(P-P)}$  = inductor ripple current
  - L = inductor value
  - $f_{SW}$  = switching frequency
  - $V_{OUT}$  = output voltage
  - $V_{IN}$  = input voltage
- (3)

Therefore, the inductor peak current is calculated with [Equation 4](#).

$$I_{L(P)} = I_{L(DC)} + \frac{\Delta I_{L(P-P)}}{2}$$
(4)

Normally, it is advisable to work with an inductor peak-to-peak current of less than 40% of the average inductor current for maximum output current. A smaller ripple from a larger valued inductor reduces the magnetic hysteresis losses in the inductor and EMI. However, in the same way, load transient response time is increased. [Table 2](#) lists the recommended inductor for the TLV61048 in the 600-kHz configuration.

**Table 2. Recommended Inductors for the TLV61048 at 600-kHz Configuration**

| PART NUMBER    | L (μH) | DCR MAX (mΩ) | SATURATION CURRENT TYPICAL (A) | SIZE (L×W×H) (mm) | VENDOR <sup>(1)</sup> |
|----------------|--------|--------------|--------------------------------|-------------------|-----------------------|
| SWPA5040S4R7NT | 4.7    | 39           | 3.9                            | 5 × 5 × 4         | Sunlord               |
| XAL4030-472ME  | 4.7    | 44.1         | 4.5                            | 4 × 4 × 3         | Coilcraft             |
| SWPA5040S100MT | 10     | 83           | 2.9                            | 5 × 5 × 4         | Sunlord               |
| XAL4040-103ME  | 10     | 92.4         | 3                              | 4 × 4 × 4         | Coilcraft             |

(1) See [Third-party Products Disclaimer](#)

### 8.2.1.2.3 Input and Output Capacitor Selection

The output capacitor is mainly selected to meet the requirements for output ripple and loop stability. This ripple voltage is related to the capacitor's capacitance and its equivalent series resistance (ESR). Assuming a ceramic capacitor with zero ESR, the minimum capacitance needed for a given ripple can be calculated by:

$$C_{OUT} = \frac{I_{OUT} \times D_{MAX}}{f_{SW} \times V_{RIPPLE}}$$

where

- $D_{MAX}$  = maximum switching duty cycle
- $V_{RIPPLE}$  = peak to peak output voltage ripple (5)

The ESR impact on the output ripple must be considered if tantalum or aluminum electrolytic capacitors are used.

Take care when evaluating the derating of a ceramic capacitor under DC bias, aging, and AC signal. For example, the DC bias can significantly reduce capacitance. A ceramic capacitor can lose more than 50% of its capacitance at its rated voltage. Therefore, always leave margin on the voltage rating to ensure adequate capacitance at the required output voltage.

TI recommends using the output capacitor with effective capacitance in the range of 3.3 μF to 10 μF for 600-kHz configuration. TI also recommends placing a small 1 μF capacitor right across the rectifier diode cathode to the GND pin of the TLV61048 to reduce the high RMS current loop's inductance. The output capacitor affects the small signal control loop stability of the boost regulator. If the output capacitor is below the range, the boost regulator can potentially become unstable. Increasing the output capacitor makes the output voltage ripple smaller in PWM mode. [Table 3](#) lists the recommended capacitor for the TLV61048.

**Table 3. Recommended Output Capacitors for the TLV61048**

| PART NUMBER       | C <sub>OUT</sub> (μF) | RATING    | PACKAGE | VENDOR <sup>(1)</sup> |
|-------------------|-----------------------|-----------|---------|-----------------------|
| TMK316BLD106KL    | 10                    | 25 V, X5R | 1206    | Taiyo Yuden           |
| CC1206KKX5R8BB106 | 10                    | 25 V, X5R | 1206    | Yageo                 |

(1) See [Third-party Products Disclaimer](#).

For input capacitor, a ceramic capacitor with more than 1 μF is enough for most applications.

### 8.2.1.2.4 Diode Rectifier Selection

Voltage rating of high side rectifier diode in boost topology should be higher than the DC output voltage, in addition, margin should be added to withstand switching spikes. Average current going through the rectifier is approximately the DC load current. For this 12 V output application, a 20 V, 1 A Schottky diode B120AF-13 is selected to provide minimal forward voltage drop to improve efficiency.

### 8.2.1.3 Application Curves



### 8.2.2 14-V Output Boost Converter

In this design example, TLV61048 is configured to output 14-V DC voltage. 1-MHz switching frequency is selected to reduce output ripple. TI recommends placing an RC snubber from the switch node to the ground node to ensure voltage spike does not exceed the specified absolute maximum rating.

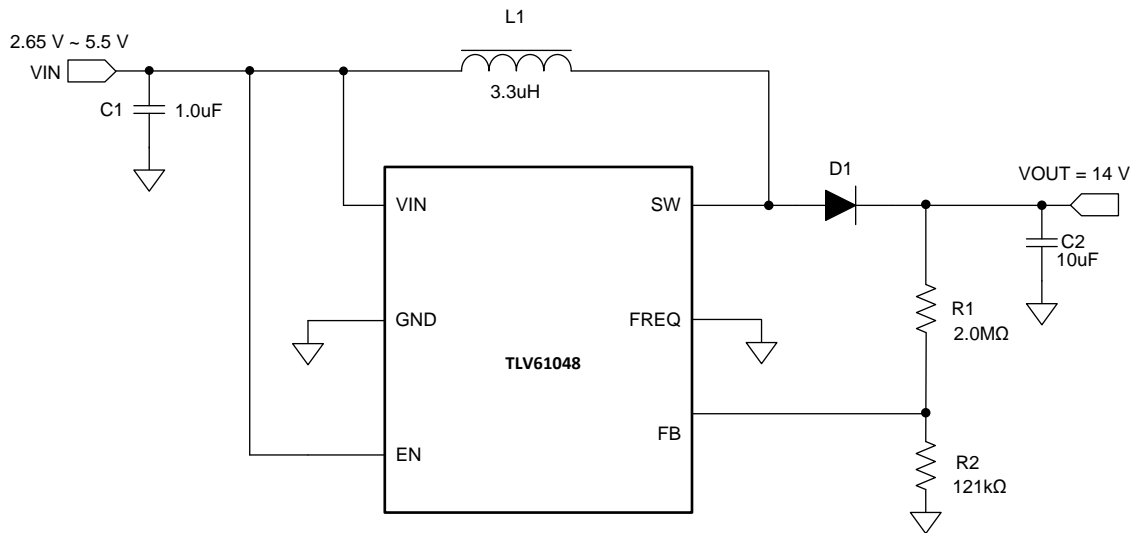

Figure 14. 14-V Boost Converter

### 8.2.2.1 Design Requirements

Table 4. Design Requirements

| PARAMETER           | VALUE           |
|---------------------|-----------------|
| Power input voltage | 2.65 V to 5.5 V |
| Output voltage      | 14 V            |
| Frequency           | 1 MHz           |
| Output current      | 0 to 300 mA     |

### 8.2.2.2 Detailed Design Procedure

#### 8.2.2.2.1 Inductor Selection

A smaller inductance is selected to push the right-half-plane-zero to a higher frequency beyond the crossover frequency of the control loop as well as reducing output ripple voltage. The recommended inductors for 1-MHz operation are listed in [Table 5](#).

Table 5. Recommended Inductors for the TLV61048 at 1-MHz Configuration

| PART NUMBER    | L (μH) | DCR MAX (mΩ) | SATURATION CURRENT TYPICAL (A) | SIZE (LxWxH) (mm) | VENDOR <sup>(1)</sup> |
|----------------|--------|--------------|--------------------------------|-------------------|-----------------------|
| SWPA5040S2R2NT | 2.2    | 25           | 5.6                            | 5 × 5 × 4         | Sunlord               |
| XAL4020-222ME  | 2.2    | 38.7         | 5.6                            | 4 × 4 × 3         | Coilcraft             |
| SWPA5040S3R3NT | 3.3    | 31           | 4.6                            | 5 × 5 × 4         | Sunlord               |
| XAL4030-332ME  | 3.3    | 28.6         | 5.5                            | 4 × 4 × 4         | Coilcraft             |

(1) See [Third-party Products Disclaimer](#).

#### 8.2.2.2.2 Input and Output Capacitor Selection

For 1-MHz configuration, use the information provided in [Input and Output Capacitor Selection](#).

## 9 Power Supply Recommendations

The device is designed to operate from an input voltage supply range between 1.5 V to 5.5 V. This input supply must be well regulated. If the input supply is located more than a few inches from the converter, additional bulk capacitance may be required in addition to the ceramic bypass capacitors. A typical choice is an electrolytic or tantalum capacitor with a value of 47  $\mu$ F. Output current of the input power supply must be rated according to the supply voltage, output voltage and output current of the TLV61048.

## 10 Layout

### 10.1 Layout Guidelines

As for all switching power supplies, especially those running at high switching frequency and high currents, layout is an important design step. If the layout is not carefully done, the regulator could suffer from instability and noise problems. To maximize efficiency, switch rise and fall time are very fast. To prevent radiation of high frequency noise (for example, EMI), proper layout of the high-frequency switching path is essential. Minimize the length and area of all traces connected to the SW pin, and always use a ground plane under the switching regulator to minimize interplane coupling. The input capacitor must not only be close to the VIN pin, but also to the GND pin in order to reduce input supply ripple.

The most critical current path for all boost converters is from the switching FET, through the rectifier diode, then the output capacitors, and back to ground of the switching FET. This high current path contains nanosecond rise and fall time and must be kept as short as possible. Therefore, the output capacitor must not only be close to the GND pin, but also to the cathode of the high side rectifier to reduce the overshoot at the SW pin.

### 10.2 Layout Example

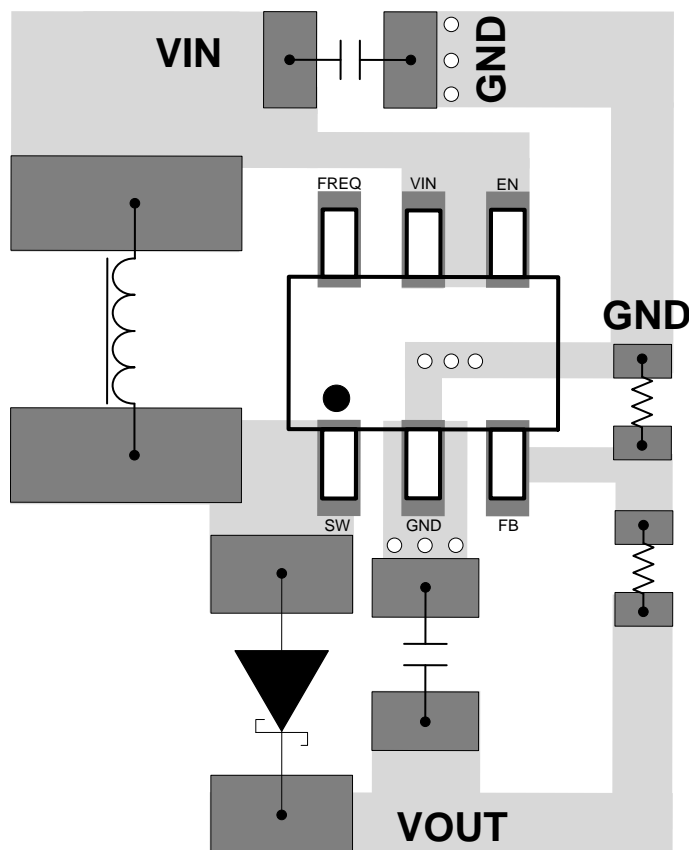

Figure 15. TLV61048 Layout

## 11 Device and Documentation Support

### 11.1 Device Support

#### 11.1.1 Third-Party Products Disclaimer

TI'S PUBLICATION OF INFORMATION REGARDING THIRD-PARTY PRODUCTS OR SERVICES DOES NOT CONSTITUTE AN ENDORSEMENT REGARDING THE SUITABILITY OF SUCH PRODUCTS OR SERVICES OR A WARRANTY, REPRESENTATION OR ENDORSEMENT OF SUCH PRODUCTS OR SERVICES, EITHER ALONE OR IN COMBINATION WITH ANY TI PRODUCT OR SERVICE.

#### 11.2 Receiving Notification of Documentation Updates

To receive notification of documentation updates, navigate to the device product folder on ti.com. In the upper right corner, click on *Alert me* to register and receive a weekly digest of any product information that has changed. For change details, review the revision history included in any revised document.

#### 11.3 Community Resources

The following links connect to TI community resources. Linked contents are provided "AS IS" by the respective contributors. They do not constitute TI specifications and do not necessarily reflect TI's views; see TI's [Terms of Use](#).

**TI E2E™ Online Community** *TI's Engineer-to-Engineer (E2E) Community*. Created to foster collaboration among engineers. At e2e.ti.com, you can ask questions, share knowledge, explore ideas and help solve problems with fellow engineers.

**Design Support** *TI's Design Support* Quickly find helpful E2E forums along with design support tools and contact information for technical support.

#### 11.4 Trademarks

E2E is a trademark of Texas Instruments.  
All other trademarks are the property of their respective owners.

#### 11.5 Electrostatic Discharge Caution



This integrated circuit can be damaged by ESD. Texas Instruments recommends that all integrated circuits be handled with appropriate precautions. Failure to observe proper handling and installation procedures can cause damage.

ESD damage can range from subtle performance degradation to complete device failure. Precision integrated circuits may be more susceptible to damage because very small parametric changes could cause the device not to meet its published specifications.

#### 11.6 Glossary

[SLYZ022](#) — *TI Glossary*.

This glossary lists and explains terms, acronyms, and definitions.

## 12 Mechanical, Packaging, and Orderable Information

The following pages include mechanical, packaging, and orderable information. This information is the most current data available for the designated devices. This data is subject to change without notice and revision of this document. For browser-based versions of this data sheet, refer to the left-hand navigation.



**PACKAGING INFORMATION**

| Orderable Device | Status<br>(1) | Package Type | Package Drawing | Pins | Package Qty | Eco Plan<br>(2) | Lead finish/<br>Ball material<br>(6) | MSL Peak Temp<br>(3) | Op Temp (°C) | Device Marking<br>(4/5) | Samples                 |
|------------------|---------------|--------------|-----------------|------|-------------|-----------------|--------------------------------------|----------------------|--------------|-------------------------|-------------------------|
| TLV61048DBVR     | ACTIVE        | SOT-23       | DBV             | 6    | 3000        | RoHS & Green    | NIPDAU                               | Level-1-260C-UNLIM   | -40 to 125   | 1VSF                    | <a href="#">Samples</a> |
| TLV61048DBVT     | ACTIVE        | SOT-23       | DBV             | 6    | 250         | RoHS & Green    | NIPDAU                               | Level-1-260C-UNLIM   | -40 to 125   | 1VSF                    | <a href="#">Samples</a> |

(1) The marketing status values are defined as follows:

**ACTIVE:** Product device recommended for new designs.

**LIFEBUY:** TI has announced that the device will be discontinued, and a lifetime-buy period is in effect.

**NRND:** Not recommended for new designs. Device is in production to support existing customers, but TI does not recommend using this part in a new design.

**PREVIEW:** Device has been announced but is not in production. Samples may or may not be available.

**OBSELETE:** TI has discontinued the production of the device.

(2) **RoHS:** TI defines "RoHS" to mean semiconductor products that are compliant with the current EU RoHS requirements for all 10 RoHS substances, including the requirement that RoHS substance do not exceed 0.1% by weight in homogeneous materials. Where designed to be soldered at high temperatures, "RoHS" products are suitable for use in specified lead-free processes. TI may reference these types of products as "Pb-Free".

**RoHS Exempt:** TI defines "RoHS Exempt" to mean products that contain lead but are compliant with EU RoHS pursuant to a specific EU RoHS exemption.

**Green:** TI defines "Green" to mean the content of Chlorine (Cl) and Bromine (Br) based flame retardants meet JS709B low halogen requirements of <=1000ppm threshold. Antimony trioxide based flame retardants must also meet the <=1000ppm threshold requirement.

(3) MSL, Peak Temp. - The Moisture Sensitivity Level rating according to the JEDEC industry standard classifications, and peak solder temperature.

(4) There may be additional marking, which relates to the logo, the lot trace code information, or the environmental category on the device.

(5) Multiple Device Markings will be inside parentheses. Only one Device Marking contained in parentheses and separated by a "~" will appear on a device. If a line is indented then it is a continuation of the previous line and the two combined represent the entire Device Marking for that device.

(6) Lead finish/Ball material - Orderable Devices may have multiple material finish options. Finish options are separated by a vertical ruled line. Lead finish/Ball material values may wrap to two lines if the finish value exceeds the maximum column width.

**Important Information and Disclaimer:**The information provided on this page represents TI's knowledge and belief as of the date that it is provided. TI bases its knowledge and belief on information provided by third parties, and makes no representation or warranty as to the accuracy of such information. Efforts are underway to better integrate information from third parties. TI has taken and continues to take reasonable steps to provide representative and accurate information but may not have conducted destructive testing or chemical analysis on incoming materials and chemicals. TI and TI suppliers consider certain information to be proprietary, and thus CAS numbers and other limited information may not be available for release.

In no event shall TI's liability arising out of such information exceed the total purchase price of the TI part(s) at issue in this document sold by TI to Customer on an annual basis.



## TAPE AND REEL INFORMATION



### QUADRANT ASSIGNMENTS FOR PIN 1 ORIENTATION IN TAPE



\*All dimensions are nominal

| Device       | Package Type | Package Drawing | Pins | SPQ  | Reel Diameter (mm) | Reel Width W1 (mm) | A0 (mm) | B0 (mm) | K0 (mm) | P1 (mm) | W (mm) | Pin1 Quadrant |
|--------------|--------------|-----------------|------|------|--------------------|--------------------|---------|---------|---------|---------|--------|---------------|
| TLV61048DBVR | SOT-23       | DBV             | 6    | 3000 | 180.0              | 8.4                | 3.2     | 3.2     | 1.4     | 4.0     | 8.0    | Q3            |
| TLV61048DBVT | SOT-23       | DBV             | 6    | 250  | 180.0              | 8.4                | 3.2     | 3.2     | 1.4     | 4.0     | 8.0    | Q3            |

**TAPE AND REEL BOX DIMENSIONS**

\*All dimensions are nominal

| Device       | Package Type | Package Drawing | Pins | SPQ  | Length (mm) | Width (mm) | Height (mm) |
|--------------|--------------|-----------------|------|------|-------------|------------|-------------|
| TLV61048DBVR | SOT-23       | DBV             | 6    | 3000 | 210.0       | 185.0      | 35.0        |
| TLV61048DBVT | SOT-23       | DBV             | 6    | 250  | 210.0       | 185.0      | 35.0        |



# EXAMPLE BOARD LAYOUT

DBV0006A

SOT-23 - 1.45 mm max height

SMALL OUTLINE TRANSISTOR

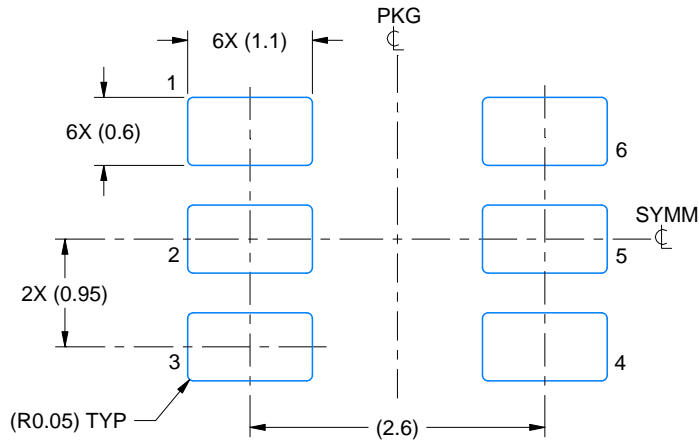

LAND PATTERN EXAMPLE  
EXPOSED METAL SHOWN  
SCALE:15X

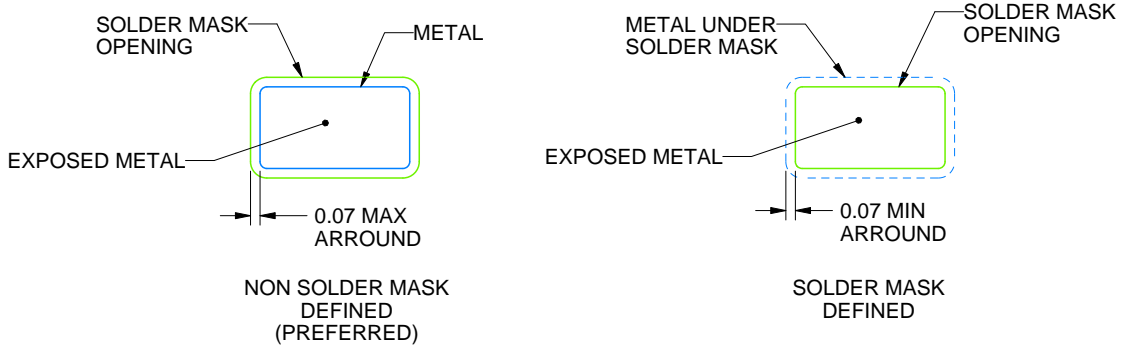

SOLDER MASK DETAILS

4214840/B 03/2018

NOTES: (continued)

- 6. Publication IPC-7351 may have alternate designs.
- 7. Solder mask tolerances between and around signal pads can vary based on board fabrication site.

# EXAMPLE STENCIL DESIGN

DBV0006A

SOT-23 - 1.45 mm max height

SMALL OUTLINE TRANSISTOR

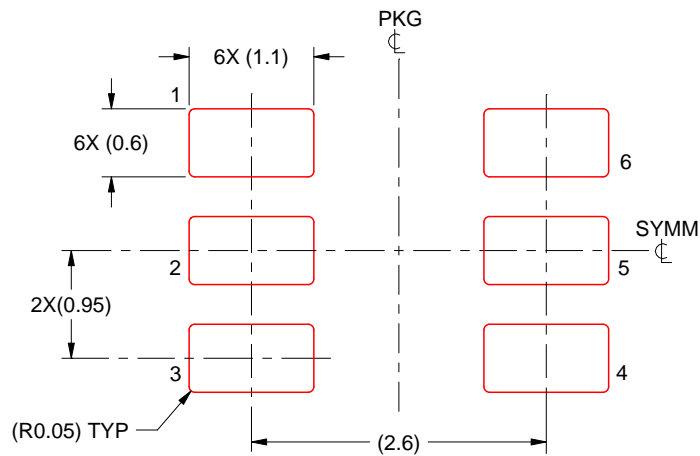

SOLDER PASTE EXAMPLE  
BASED ON 0.125 mm THICK STENCIL  
SCALE:15X

4214840/B 03/2018

NOTES: (continued)

8. Laser cutting apertures with trapezoidal walls and rounded corners may offer better paste release. IPC-7525 may have alternate design recommendations.
9. Board assembly site may have different recommendations for stencil design.

## IMPORTANT NOTICE AND DISCLAIMER

TI PROVIDES TECHNICAL AND RELIABILITY DATA (INCLUDING DATASHEETS), DESIGN RESOURCES (INCLUDING REFERENCE DESIGNS), APPLICATION OR OTHER DESIGN ADVICE, WEB TOOLS, SAFETY INFORMATION, AND OTHER RESOURCES "AS IS" AND WITH ALL FAULTS, AND DISCLAIMS ALL WARRANTIES, EXPRESS AND IMPLIED, INCLUDING WITHOUT LIMITATION ANY IMPLIED WARRANTIES OF MERCHANTABILITY, FITNESS FOR A PARTICULAR PURPOSE OR NON-INFRINGEMENT OF THIRD PARTY INTELLECTUAL PROPERTY RIGHTS.

These resources are intended for skilled developers designing with TI products. You are solely responsible for (1) selecting the appropriate TI products for your application, (2) designing, validating and testing your application, and (3) ensuring your application meets applicable standards, and any other safety, security, or other requirements. These resources are subject to change without notice. TI grants you permission to use these resources only for development of an application that uses the TI products described in the resource. Other reproduction and display of these resources is prohibited. No license is granted to any other TI intellectual property right or to any third party intellectual property right. TI disclaims responsibility for, and you will fully indemnify TI and its representatives against, any claims, damages, costs, losses, and liabilities arising out of your use of these resources.

TI's products are provided subject to TI's Terms of Sale ([www.ti.com/legal/termsofsale.html](http://www.ti.com/legal/termsofsale.html)) or other applicable terms available either on [ti.com](http://ti.com) or provided in conjunction with such TI products. TI's provision of these resources does not expand or otherwise alter TI's applicable warranties or warranty disclaimers for TI products.

Mailing Address: Texas Instruments, Post Office Box 655303, Dallas, Texas 75265  
Copyright © 2020, Texas Instruments Incorporated