

181-001 • M29504/05 fiber optic socket terminus, size 16 MIL-DTL-38999 Series III Type

M29504/05 TYPE, STYLE 1 SOCKET TERMINUS FOR MIL-DTL-38999 SERIES III



Part Number	Fiber Size Core/Cladding/Coating (Microns)	Ø A (Microns)	Ref. M29504/05-XXXX
181-001-125	9/125 (Singlemode)	125.5	M29504/05-4237
181-001-126S	9/125 (Singlemode)	126.0	M29504/05-4238
181-001-126	50/125 & 62.5/125	126.0	M29504/05-4239
181-001-127	50/125 & 62.5/125	127.0	M29504/05-4046
181-001-142	100/140	142.0	M29504/05-4049
181-001-144	100/140	144.0	N/A
181-001-145	100/140	145.0	M29504/05-4050
181-001-156	62.5/125/155 (Polyimide)	156.0	M29504/05-4240
181-001-157	62.5/125/155 (Polyimide)	157.0	M29504/05-4241
181-001-173	100/140/172 (Polyimide)	173.0	M29504/05-4088
181-001-175	100/140/172 (Polyimide)	175.0	M29504/05-4242
181-001-231	200/230	231.0	N/A
181-001-236	200/230	236.0	N/A
181-001-286	200/280	286.0	N/A
181-001-448	400/440	448.0	N/A
181-001-533	486/500	533.0	N/A

Consult factory for additional sizes and QPL status

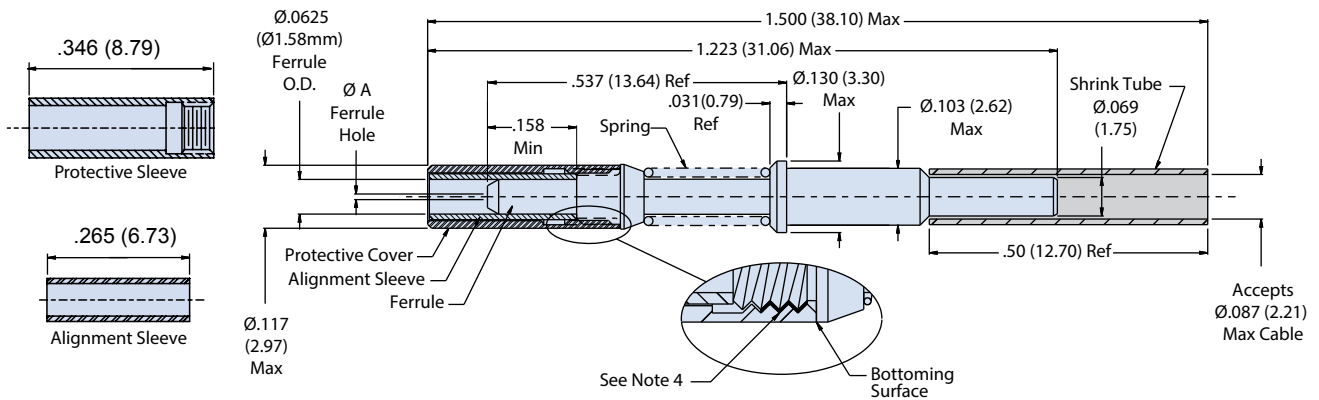

Ceramic alignment sleeve supplied with terminus. Add **K** to the end of part number development to supply with optional stainless steel alignment sleeve e.g. 181-001-126**K**.

ACCESSORIES	
Part Number	Description
181-001-S	Alignment Sleeve, Split Ceramic (standard)
181-001-K	Alignment Sleeve, Split Stainless Steel
181-001-C	Protective cover

NOTES

- Alignment sleeve & protective cover are supplied with terminus and may be ordered separately (see accessories table).
- Insertion/extraction tool: P/N M81969/14-03 or equivalent
- For socket dust cap use part number 187-019 over ferrule and 187-029 over protective cover
- Threaded protective cover must be retained using threadlocker "loctite 222" prior to insertion into connector. See Glenair assembly procedure GAP-015 for termination instructions
- Hand polishing tool: 182-001S or 182-001SW
- Material/Finish
 - Ferrule: zirconia ceramic
 - Alignment sleeve: zirconia ceramic or stainless steel/passivate.
 - Terminus body, spring, cover: stainless steel/passivate
 - Shrink tube: kynar

Mouser Electronics

Authorized Distributor

Click to View Pricing, Inventory, Delivery & Lifecycle Information:

[Glenair:](#)

[181-001-125](#)