



1A Step-Down DC-DC Converter ME3102

General Description

The ME3102 is a step-down current-mode, DC-DC converter. At heavy load, the constant-frequency PWM control performs excellent stability and transient response. To ensure the longest battery life in portable applications, the ME3102 provides a power-saving pulse -Skipping Modulation (PSM) mode to reduce quiescent current under light load operation to save power.

The ME3102 supports a range of input voltages from 2.5V to 5.5V, allowing the use of a single Li+/Li-polymer cell, multiple Alkaline/NiMH cell, USB, and other standard power sources. The output voltage is adjustable from 0.6V to the input voltage, while the part number suffix ME3102 indicates pre-set output voltage of 3.3V, 2.8V, 2.5V, 1.8V, 1.5V, 1.2V or adjustable. All versions employ internal power switch and synchronous rectifier for to minimize external part count and realize high efficiency. During shutdown, the input is disconnected from the output and the shutdown current is less than 0.1 μ A. Other key features include under-voltage lockout to prevent deep battery discharge.

Typical Applications

- Cellular Phone
- Portable Electronics
- Wireless Devices
- Cordless Phone
- Computer Peripherals
- Battery Powered Widgets
- Electronic Scales
- Digital Frame

Features

- Efficiency up to 96%
- Only 45 μ A (TYP.) Quiescent Current
- Output Current: Up to 1A
- Internal Synchronous Rectifier
- 1.75MHz/1.4MHz Switching Frequency
- Soft Start
- Short Circuit Protection

Package

- 5-pin SOT23-5
- 6-pin DFN2*2-6

Typical Application

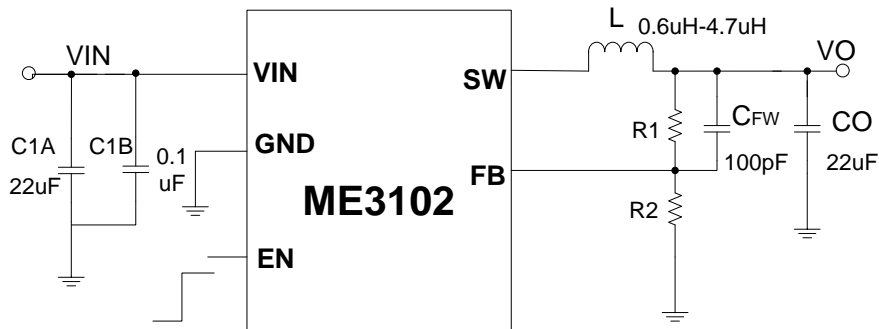

$$V_o = 0.6 \times (1 + R_1/R_2)$$

Selection Guide

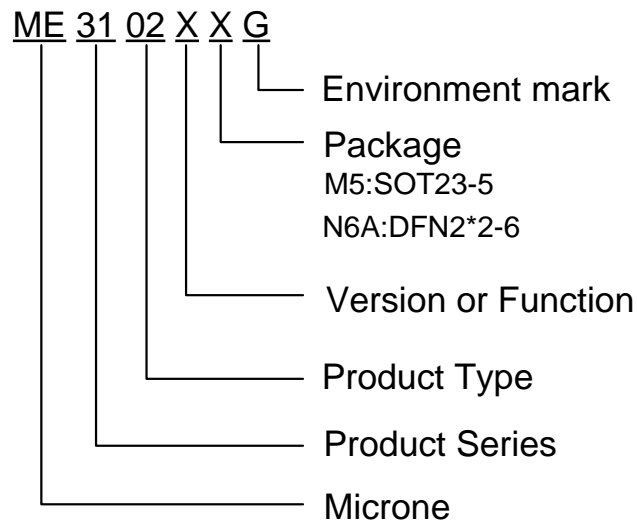

product series	product description
ME3102AM5G	VFB=0.6V; Fosc=1.75MHz; Package: SOT23-5
ME3102BM5G	VFB=0.6V; Fosc=1.4MHz; Package: SOT23-5
ME3102BN6AG	VFB=0.6V; Fosc=1.4MHz; Package: DFN2*2-6
ME3102CN6AG	VFB=0.6V; Fosc=1.4MHz; Package: DFN2*2-6; Different Pin Assignment

NOTE: If you need other voltage and package, please contact our sales staff.

Pin Configuration

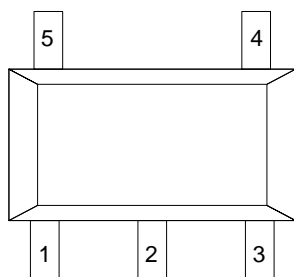

SOT23-5

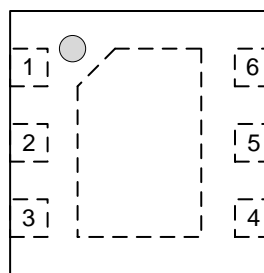

DFN2*2-6

Pin Assignment

Pin Number (SOT23-5)	Pin Number (DFN2*2-6L)		Name	Function
	ME3102B	ME3102C		
ME3102A/B	ME3102B	ME3102C		
1	3	4	EN	Chip Enable
2	2	6	GND	Ground
3	1	1	SW	Switch
4	5	5	V _{IN}	Input
5	4	3	FB	Feedback
	6	2	NC	No Connect

Block Diagram

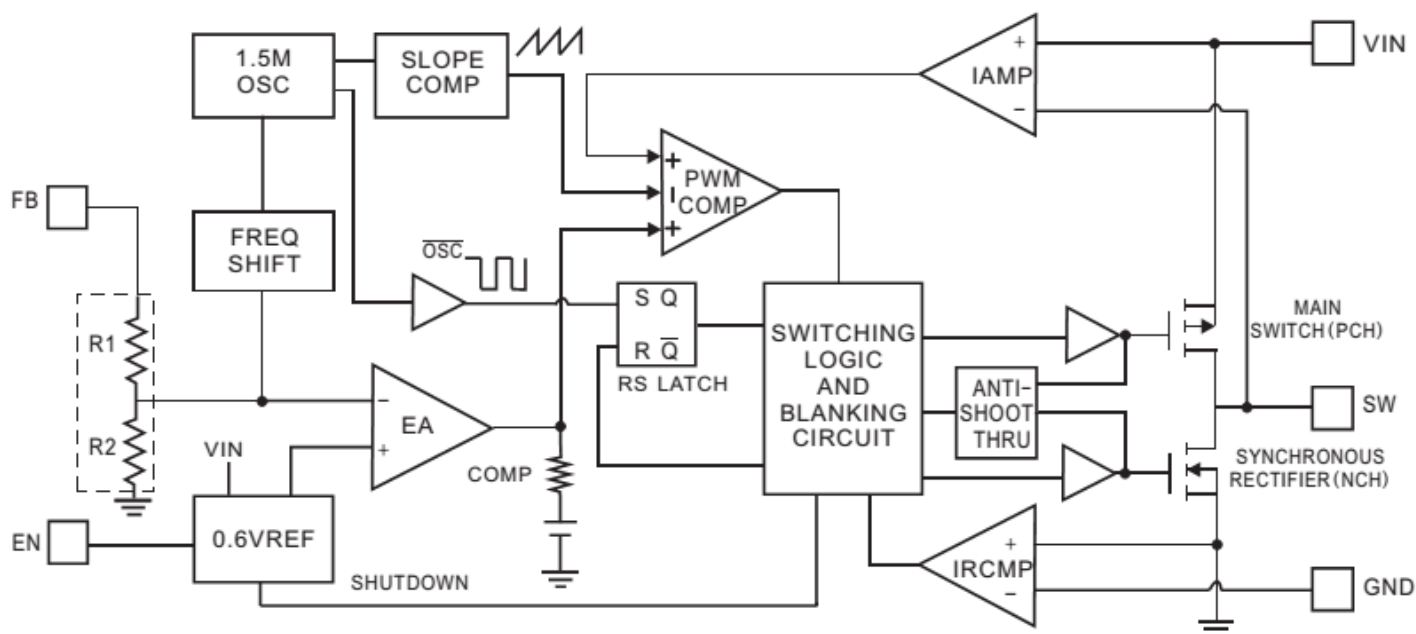

Absolute Maximum Ratings

Parameter		Symbol	Rating	Unit
Power supply voltage, V_{IN}		V_{IN}	6.0	V
voltage at EN、FB Pin		V_{EN}, V_{FB}	6.0	V
voltage at SW Pin		V_{SW}	-0.3~ V_{IN}	V
Internal Power Dissipation	SOT23-5	P_D	0.6	mW
	DFN2*2-6		1.3	mW
Thermal resistance	SOT23-5	θ_{JA}	210	°C/W
	DFN2*2-6		95	
Operating Ambient Temperature		T_{opr}	-40~+85	°C
Storage Temperature		T_{stg}	-55~+150	°C
Soldering temperature and time		T_{solder}	260(10S)	°C

Electrical Characteristics

$V_{IN}=3.6V$, $V_O=1.8V$, $C_{IN}=22\mu F//0.1\mu F$, $C_O=22\mu F$, $L=2.2\mu H$, $T_A=25^\circ C$, unless otherwise noted.

Parameter	Symbol	Test condition	Min	Typ.	Max	Unit	
Input voltage range	V_{IN}		2.5	-	5.5	V	
Regulated Feedback Voltage	V_{FB}		0.588	0.6	0.612	V	
Regulated Output Voltage Accuracy	V_O	$I_O=100mA$	-3	-	+3	%	
Output Voltage Line Regulation	LNR	$V_{IN}=2.5V$ to $5V$, $I_O=10mA$	-	0.2	0.5	%/V	
Output Voltage Load Regulation	LDR	$I_O=1.0mA$ to $800mA$	-	0.5	1.5	%	
Quiescent Current	I_Q	No load	-	45	70	μA	
Shutdown Current	I_{SD}	$V_{EN}=0V$	-	0.1	1	μA	
Current limiting protection	I_{limit}			1.6		A	
SW Leakage Current	I_{LSW}		-1		1	μA	
Oscillator Frequency	F_{OSC}	$V_O=100\%$	ME3102A	1.45	1.75	2.1	MHz
			ME3102B/C	1.2	1.4	1.8	
		$V_{FB}=0V$ or $V_O=0V$	ME3102A		600		KHz
			ME3102B/C		500		
Drain-Source On-State Resistance	$R_{DS(ON)}$	$I_{DS}=100mA$	P MOSFET	-	0.3	0.6	Ω
			N MOSFET	-	0.3	0.6	Ω
High Efficiency	η		-	96	-	%	
EN Threshold High	V_{EH}		1.5	-	-	V	
EN Threshold Low	V_{EL}		-	-	0.3	V	

Typical Performance Characteristics

1. Efficiency VS Output Current ($V_O=1.8V$)

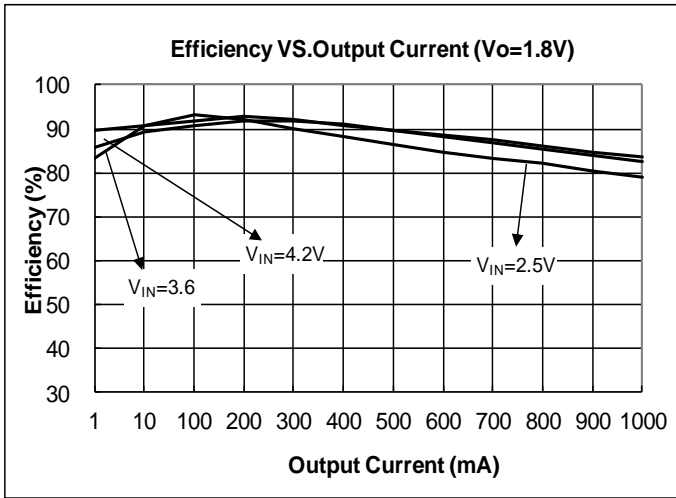

Efficiency VS Output Current ($V_O=3.3V$)

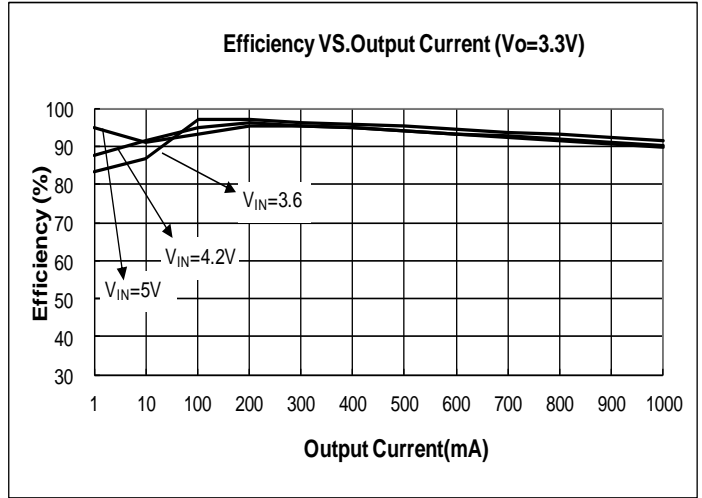

2. Efficiency VS Input Voltage ($V_O=1.8V$)

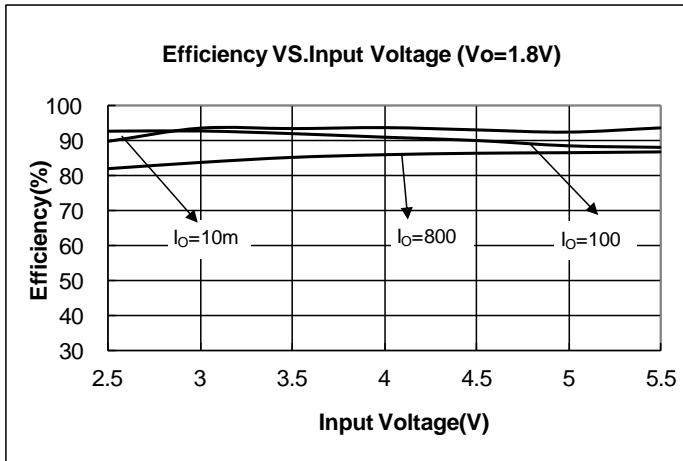

Efficiency VS Input Voltage ($V_O=3.3V$)

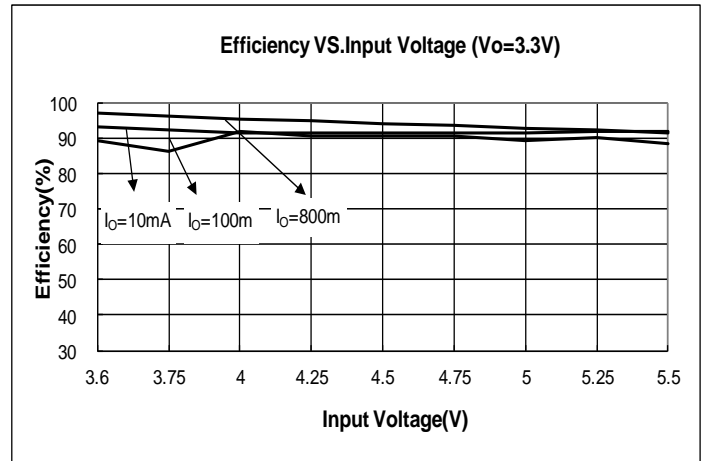

3. V_{FB} VS Input Voltage

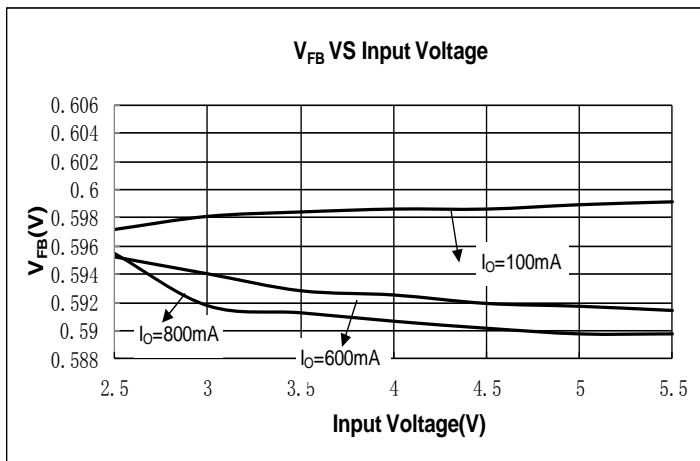

4. V_{FB} VS Output Current

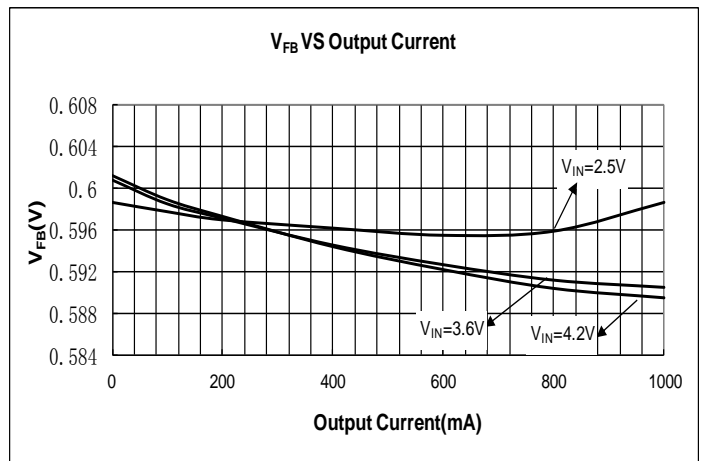

5. Output Voltage VS Output Current ($V_O=1.8V$)

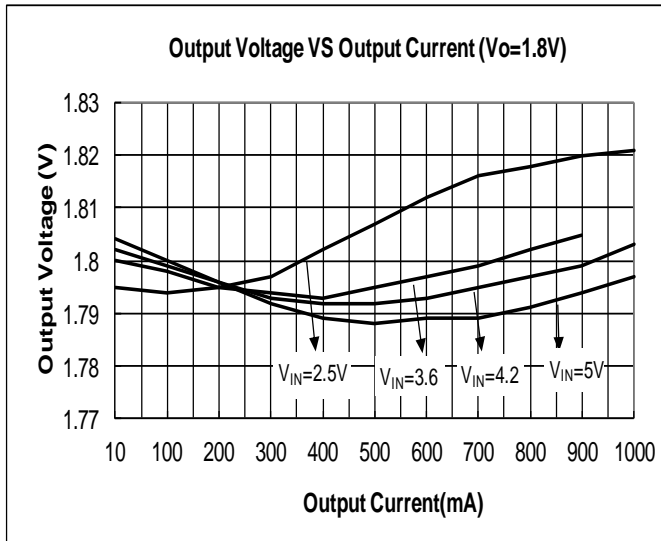

6. V_{FB} VS Temperature

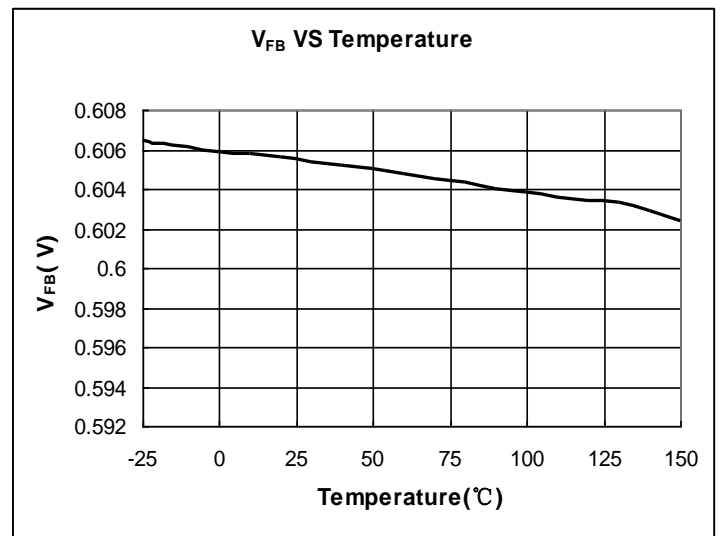

7. Dynamic Supply Current VS Input Voltage ($V_O=1.8V$)

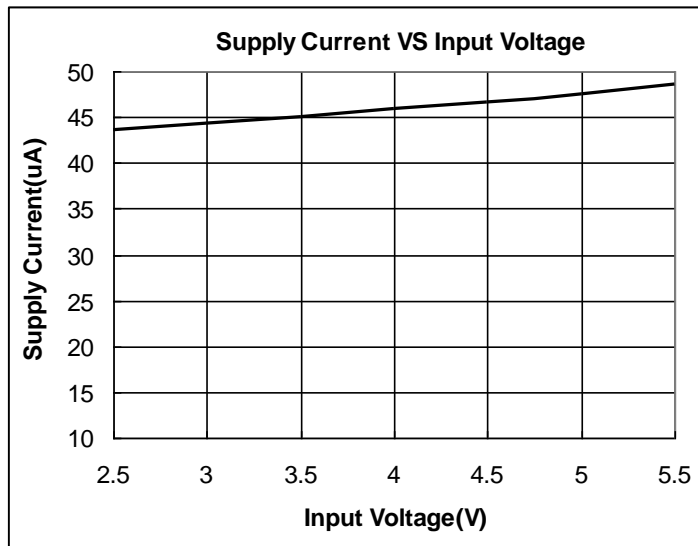

8. Dynamic Supply Current VS Temperature ($V_{IN}=3.6V$, $V_O=1.8V$)

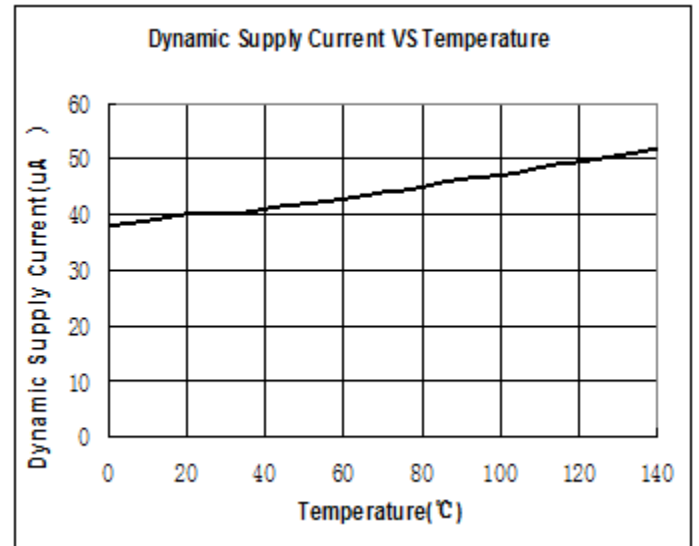

9. Oscillator Frequency VS Input Voltage

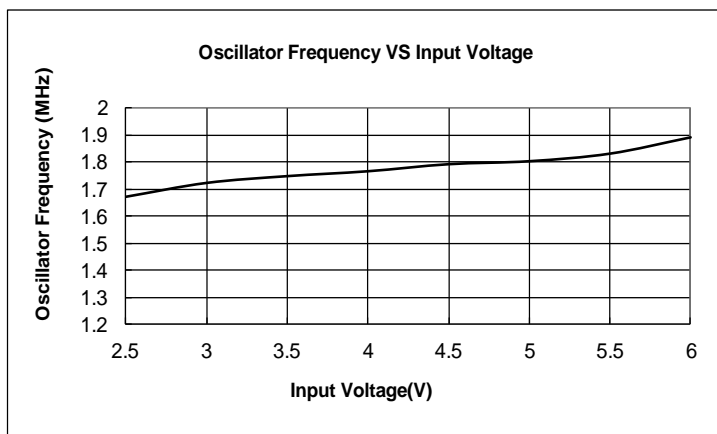

Application Information

The basic ME3102 application circuit is shown as up figures. External component selection is determined by the load requirement, selecting L first and then C_{IN} and C_{OUT}. It is better to use the patch ceramic capacitors at C_{OUT}.

Inductor Selection

For most applications, the value of the inductor will fall in the range of 0.6μH to 4.7μH. Its value is chosen based on the desired ripple current. Large value inductors lower ripple current and small value inductors result in higher ripple currents. Higher V_{IN} or V_{OUT} also increases the ripple current as shown in equation 1. A reasonable starting point for setting ripple current is ΔI_L=400mA (40% of 1A).

$$\Delta I_L = \frac{1}{f \times L} V_{OUT} \left(1 - \frac{V_{OUT}}{V_{IN}} \right)$$

The DC current rating of the inductor should be at least equal to the maximum load current plus half the ripple current to prevent core saturation. Thus, a 2A rated inductor should be enough for most applications. For better efficiency, choose a low DC-resistance inductor.

V _O	0.6V	1.2V	1.5V	1.8V/2.5V/2.8V/3.3V
L	0.6μH	1.2μH	1.5μH	2.2μH/3.3μH/4.3μH

C_{IN} and C_{OUT} Selection

In continuous mode, the source current of the top MOSFET is a square wave of duty cycle V_{OUT}/V_{IN}. To prevent large voltage transients, a low ESR input capacitor sized for the maximum RMS current must be used. The maximum RMS capacitor current is given by: C_{IN} required

$$I_{RMS} \cong I_{OMAX} \frac{[V_{OUT} (V_{IN} - V_{OUT})]^{1/2}}{V_{IN}}$$

This formula has a maximum at V_{IN}=2V_{OUT}, where I_{RMS}=I_{OUT}/2. This simple worst-case condition is commonly used for design because even significant deviations do not offer much relief. Note that the capacitor manufacturer's ripple current ratings are often based on 2000 hours of life. This makes it advisable to further derate the capacitor, or choose a capacitor rated at a higher temperature than required. Consult the manufacturer if there is any question.

The selection of C_{OUT} is driven by the required effective series resistance (ESR). Typically, once the ESR requirement for C_{OUT} has been met, the RMS current rating generally far exceeds the IRIPPLE (P-P) requirement.

The output ripple ΔV_{OUT} is determined by:

$$\Delta V_{OUT} \cong \Delta I_L \left(ESR + \frac{1}{8fC_{OUT}} \right)$$

Where f = operating frequency, C_{OUT}=output capacitance and ΔI_L= ripple current in the inductor. For a fixed output

voltage, the output ripple is highest at maximum input voltage since ΔI increases with input voltage.

Using Ceramic Input and Output Capacitors

Higher values, lower cost ceramic capacitors are now becoming available in smaller case sizes. Their high ripple current, high voltage rating and low ESR make them ideal for switching regulator applications. Using ceramic capacitors can achieve very low output ripple and small circuit size.

When choosing the input and output ceramic capacitors, choose the X5R or X7R dielectric formulations. These dielectrics have the best temperature and voltage characteristics of all the ceramics for a given value and size.

Setting the Output Voltage

The internal reference is 0.6V (Typical). The output voltage is calculated as below:

$$V_o = 0.6 \times \left(1 + \frac{R1}{R2} \right)$$

The output voltage is given by Table 1.

Table 1: Resistor selection for output voltage setting

V_o (V)	R1 (K Ω)	R2 (K Ω)
1.2	100	100
1.5	150	100
1.8	200	100
2.5	380	120
3.3	540	120

100% Duty Cycle Operation

As the input voltage approaches the output voltage, the converter turns the P-channel transistor continuously on. In this mode the output voltage is equal to the input voltage minus the voltage drop across the P- channel transistor:

$$V_{OUT} = V - I_{LOAD} (R_{DSON} + R_L)$$

where R_{DSON} = P-channel switch ON resistance, I_{LOAD} = Output current , R_L = Inductor DC resistance

Soft-Start

The ME3102 has an internal soft-start circuit that limits the in-rush current during start-up. This prevents possible voltage drops of the input voltage and eliminates the output voltage overshoot.

Short Circuit Protection

The switch peak current is limited cycle-by-cycle to a typical value of 1600mA. In the event of an output voltage short circuit, the device operates with a frequency of 600KHz and minimum duty cycle, therefore the average input current is typically 200mA.

PCB Layout Check List

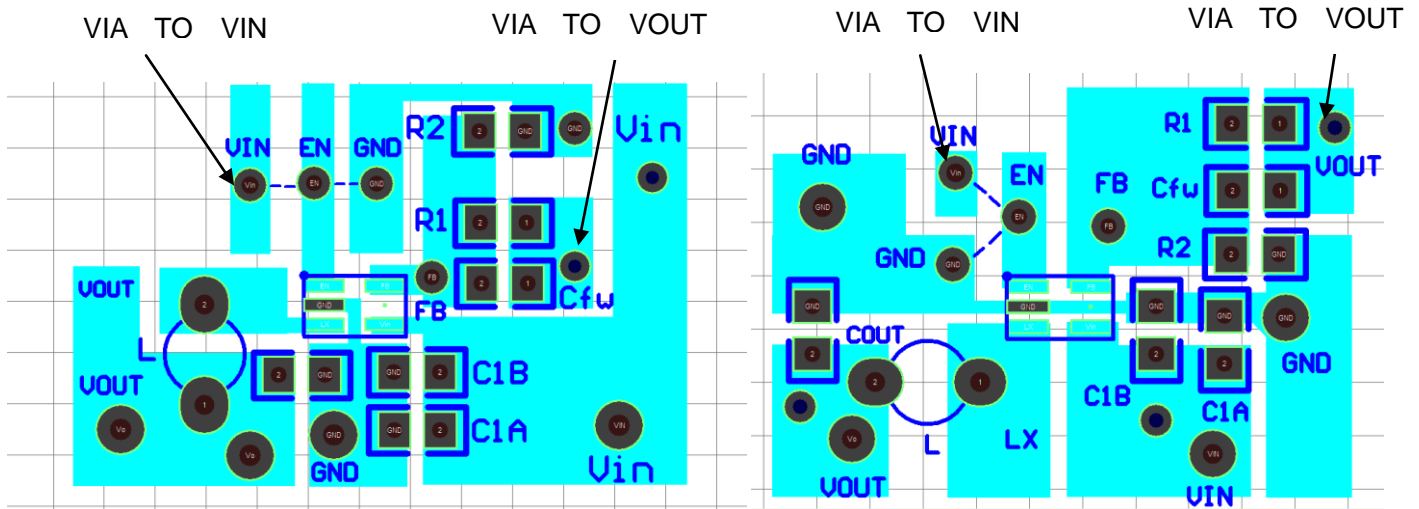

When laying out the printed circuit board, the following checklist should be used to ensure proper operation of the ME3102.

1. The power traces, consisting of the GND trace, the SW trace and the V_{IN} trace should be kept short, direct and wide.
2. Does the V_{FB} pin connect directly to the feedback resistors? The resistive divider R1/R2 must be connected between the (+) plate of C_{OUT} and ground.
3. Does the (+) plate of C_{IN} connect to V_{IN} as closely as possible? This capacitor provides the AC current to the internal power MOSFETs.
4. Keep the switching node, SW, away from the sensitive V_{FB} node.
5. Keep the (-) plates of C and C_{OUT} as close as possible.

Package Information

- Package type:SOT23-5

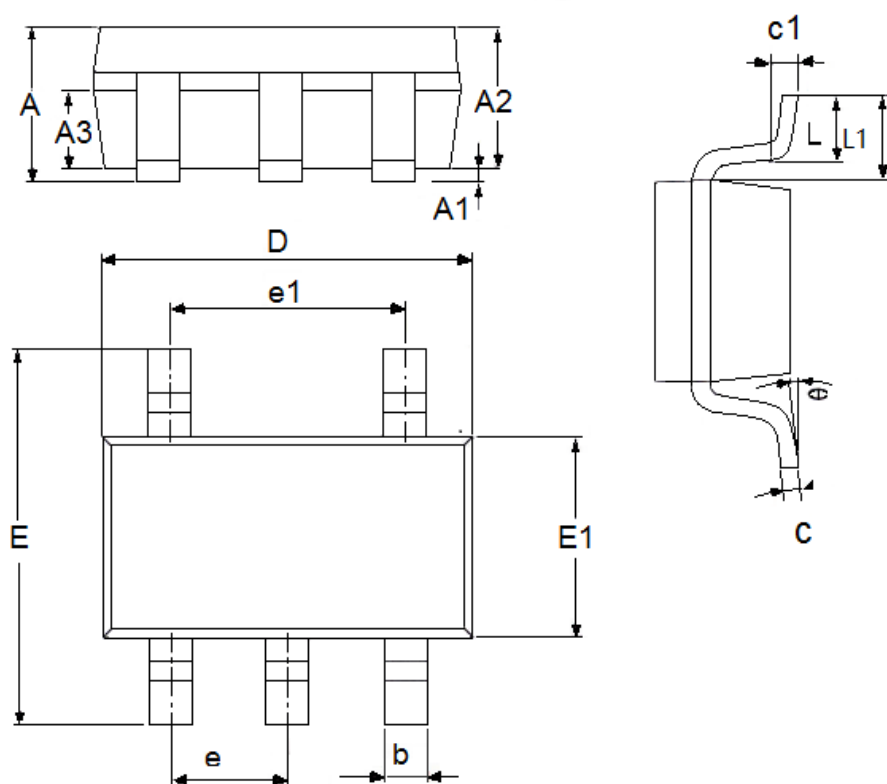

DIM	Millimeters		Inches	
	Min	Max	Min	Max
A	1.05	1.45	0.0413	0.0571
A1	0	0.15	0.0000	0.0059
A2	0.9	1.3	0.0354	0.0512
A3	0.6	0.7	0.0236	0.0276
b	0.25	0.5	0.0098	0.0197
c	0.1	0.23	0.0039	0.0091
D	2.82	3.05	0.1110	0.1201
e1	1.9(TYP)		0.0748(TYP)	
E	2.6	3.05	0.1024	0.1201
E1	1.5	1.75	0.0512	0.0689
e	0.95(TYP)		0.0374(TYP)	
L	0.25	0.6	0.0098	0.0236
L1	0.59(TYP)		0.0232(TYP)	
θ	0	8°	0.0000	8°
c1	0.2(TYP)		0.0079(TYP)	

● Package type:DFN2*2-6

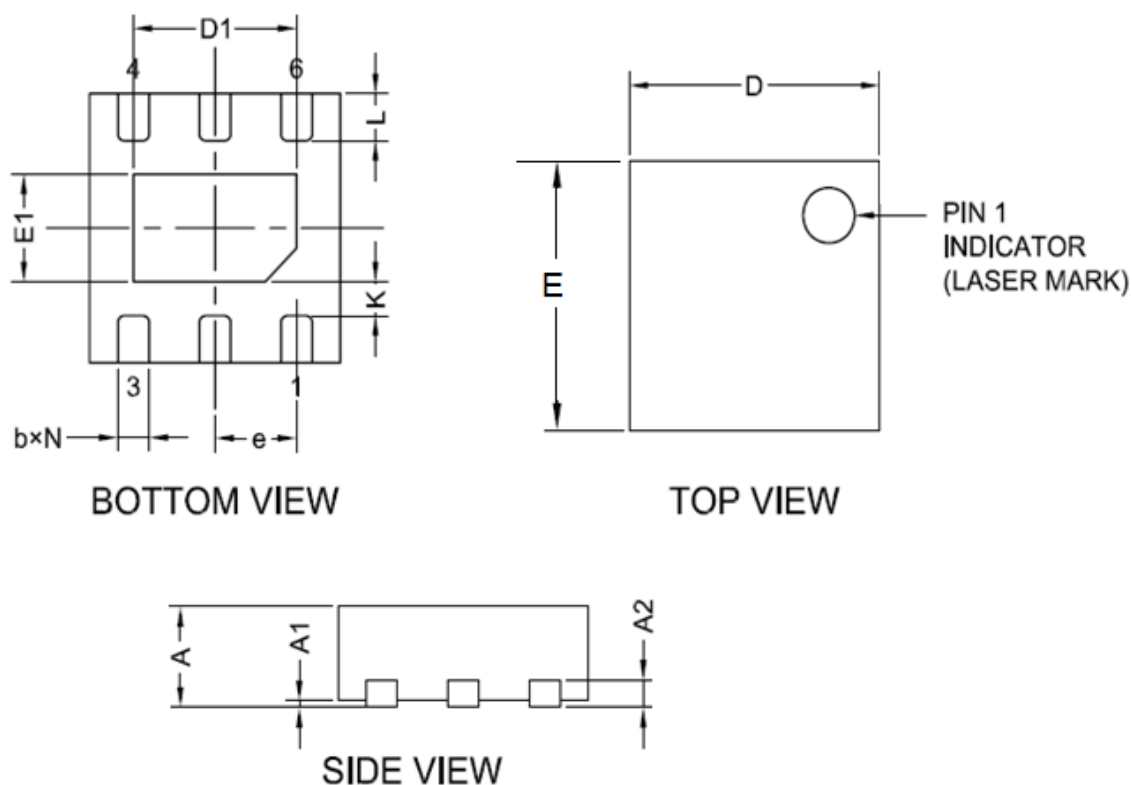

DIM	Millimeters		Inches	
	Min	Max	Min	Max
A	0.7	0.8	0.0276	0.0315
A1	0	0.05	0	0.002
A2	0.203(TYP)		0.008(TYP)	
b	0.2	0.35	0.0078	0.0138
D	1.9	2.1	0.0748	0.0827
E	1.9	2.1	0.0748	0.0827
E1	0.5	0.9	0.0197	0.0354
e	0.65(TYP)		0.0256(TYP)	
L	0.25	0.426	0.0098	0.0168
K	0.2	—	0.0079	—
D1	1	1.45	0.0393	0.0571

- The information described herein is subject to change without notice.
- Nanjing Micro One Electronics Inc is not responsible for any problems caused by circuits or diagrams described herein whose related industrial properties, patents, or other rights belong to third parties. The application circuit examples explain typical applications of the products, and do not guarantee the success of any specific mass-production design.
- Use of the information described herein for other purposes and/or reproduction or copying without the express permission of Nanjing Micro One Electronics Inc is strictly prohibited.
- The products described herein cannot be used as part of any device or equipment affecting the human body, such as exercise equipment, medical equipment, security systems, gas equipment, or any apparatus installed in airplanes and other vehicles, without prior written permission of Nanjing Micro One Electronics Inc.
- Although Nanjing Micro One Electronics Inc exerts the greatest possible effort to ensure high quality and reliability, the failure or malfunction of semiconductor products may occur. The user of these products should therefore give thorough consideration to safety design, including redundancy, fire-prevention measures, and malfunction prevention, to prevent any accidents, fires, or community damage that may ensue.