

TL431-Q1 / TL432-Q1 Adjustable Precision Shunt Regulator

1 Features

- Qualified for automotive applications
- AEC-Q100 test guidance with the following:
 - Device temperature grade 1: -40°C to 125°C ambient operating temperature range
- Reference voltage tolerance at 25°C :
 - 1% (A Grade)
 - 0.5% (B Grade)
- Typical temperature drift:
 - 14 mV (Q Temp)
- Low output noise
- $0.2\text{-}\Omega$ Typical output impedance
- Sink-current capability: 1 mA to 100 mA
- Adjustable output voltage: V_{REF} to 36 V

2 Applications

- Adjustable voltage and current referencing
- Secondary side regulation in flyback SMPSs
- Zener replacement
- Voltage monitoring
- Comparator with integrated reference

3 Description

The TL431LI-Q1 / TL432LI-Q1 are pin-to-pin alternatives to TL431-Q1 / TL432-Q1. TL43xLI-Q1 offers better stability, lower temperature drift ($V_{\text{I(dev)}}$), and lower reference current (I_{ref}) for improved system accuracy.

The TL431-Q1 is a three-pin adjustable shunt regulator with specified thermal stability over applicable automotive temperature ranges. The output voltage can be set to any value from V_{REF} (approximately 2.5 V) to 36 V, with two external resistors (see Figure 28). This device has a typical output impedance of $0.2\ \Omega$. Active output circuitry provides a sharp turnon characteristic, making this device an excellent replacement for Zener diodes in many applications, such as onboard regulation, adjustable power supplies, and switching power supplies.

The TL432-Q1 has exactly the same functionality and electrical specifications as the TL431-Q1 device, but has a different pinout for the DBZ package.

Device Information⁽¹⁾

PART NUMBER	PACKAGE	BODY SIZE (NOM)
TL431A-Q1	SOT-23 (5)	2.90 mm x 1.60 mm
TL43x-Q1	SOT-23 (3)	2.92 mm x 1.30 mm

(1) For all available packages, see the orderable addendum at the end of the data sheet.

Simplified Schematic

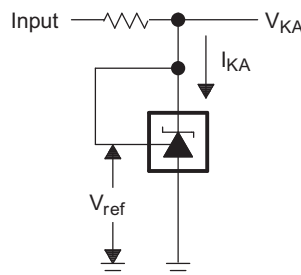

Copyright © 2016, Texas Instruments Incorporated



Table of Contents

1 Features	1	8.3 Feature Description	12
2 Applications	1	8.4 Device Functional Modes	12
3 Description	1	9 Application and Implementation	13
4 Revision History	2	9.1 Application Information	13
5 Pin Configuration and Functions	3	9.2 Typical Applications	13
6 Specifications	4	10 Power Supply Recommendations	18
6.1 Absolute Maximum Ratings	4	11 Layout	18
6.2 ESD Ratings	4	11.1 Layout Guidelines	18
6.3 Recommended Operating Conditions	4	11.2 Layout Example	18
6.4 Thermal Information	4	12 Device and Documentation Support	19
6.5 Electrical Characteristics: TL43x-Q1	4	12.1 Documentation Support	19
6.6 Electrical Characteristics: TL43xA-Q1	5	12.2 Related Links	19
6.7 Electrical Characteristics: TL43xB-Q1	5	12.3 Receiving Notification of Documentation Updates	19
6.8 Typical Characteristics	6	12.4 Community Resources	19
7 Parameter Measurement Information	9	12.5 Trademarks	19
8 Detailed Description	11	12.6 Electrostatic Discharge Caution	19
8.1 Overview	11	12.7 Glossary	19
8.2 Functional Block Diagram	11	13 Mechanical, Packaging, and Orderable Information	20

4 Revision History

NOTE: Page numbers for previous revisions may differ from page numbers in the current version.

Changes from Revision E (November 2016) to Revision F	Page
• The TL431LI-Q1 / TL432LI-Q1 are pin-to-pin alternatives to TL431-Q1 / TL432-Q1. TL43xLI-Q1 offers better stability, lower temperature drift (VI(dev)), and lower reference current (Iref) for improved system accuracy.	1
• Merged the TL431-Q1 with the TL432-Q1 data sheet.	1

Changes from Revision D (March 2013) to Revision E	Page
• Added <i>Applications</i> section, <i>Device Information</i> table, <i>Pin Configuration and Functions</i> section, <i>Specifications</i> section, <i>ESD Ratings</i> table, <i>Detailed Description</i> section, <i>Application and Implementation</i> section, <i>Power Supply Recommendations</i> section, <i>Layout</i> section, <i>Device and Documentation Support</i> section, and <i>Mechanical, Packaging, and Orderable Information</i> section	1
• Deleted <i>Ordering Information</i> table; see <i>Package Option Addendum</i> at the end of the data sheet	1
• Added <i>Thermal Information</i> table	4
• Changed R _{0JA} values for 5-pin DBV (SOT-23) From: 206 To: 215 and for 3-pin DBZ (SOT-23) From: 206 To: 334.7	4

5 Pin Configuration and Functions

**TL431A-Q1 DBV Package
5-Pin SOT-23
Top View**

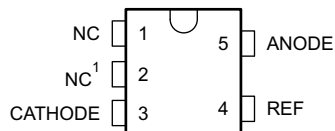

(1) Pin 2 is connected internally to ANODE (die substrate) and must be left floating or connected to ANODE.

**TL431-Q1 DBZ Package
3-Pin SOT-23
Top View**

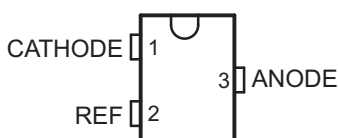

**TL432-Q1 DBZ Package
3-Pin SOT-23
Top View**

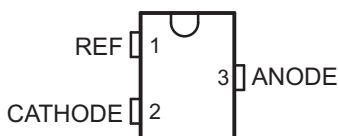

Pin Functions

NAME	PIN			I/O	DESCRIPTION
	TL431A-Q1 DBV	TL431-Q1 DBZ	TL432-Q1 DBZ		
ANODE	5	3	3	O	Common pin, normally connected to ground.
CATHODE	3	1	2	I/O	Shunt current or voltage input
NC	1, 2	—	—	—	No connection ⁽¹⁾
REF	4	2	1	I	Threshold relative to common anode

(1) Pin 2 of the 5-pin DBV (SOT-23) package is connected internally to ANODE (die substrate) and must be left floating or connected to ANODE.

6 Specifications

6.1 Absolute Maximum Ratings

 over operating free-air temperature range (unless otherwise noted)⁽¹⁾

		MIN	MAX	UNIT
Cathode voltage ⁽²⁾			37	V
Continuous cathode current		–100	150	mA
Reference input current	Low	–50		μA
	High		10	mA
Operating junction temperature, T _J			150	°C
Storage temperature, T _{stg}		–65	150	°C

- (1) Stresses beyond those listed under *Absolute Maximum Ratings* may cause permanent damage to the device. These are stress ratings only, which do not imply functional operation of the device at these or any other conditions beyond those indicated under *Recommended Operating Conditions*. Exposure to absolute-maximum-rated conditions for extended periods may affect device reliability.
- (2) Voltage values are with respect to the ANODE pin, unless otherwise noted.

6.2 ESD Ratings

		VALUE	UNIT
V _(ESD)	Electrostatic discharge	Human-body model (HBM), per AEC Q100-002 ⁽¹⁾	±2500
		Charged-device model (CDM), per AEC Q100-011	±1000
		Machine model (MM)	±200

- (1) AEC Q100-002 indicates that HBM stressing shall be in accordance with the ANSI/ESDA/JEDEC JS-001 specification.

6.3 Recommended Operating Conditions

over operating free-air temperature range (unless otherwise noted)

		MIN	MAX	UNIT
V _{KA}	Cathode voltage	V _{REF}	36	V
I _{KA}	Cathode current	1	100	mA
T _A	Operating free-air temperature	–40	125	°C

6.4 Thermal Information

THERMAL METRIC ⁽¹⁾	TL43x-Q1		UNIT	
	DBV (SOT-23)	DBZ (SOT-23)		
	5 PINS	3 PINS		
R _{θJA}	Junction-to-ambient thermal resistance	215	334.7	°C/W
R _{θJC(top)}	Junction-to-case (top) thermal resistance	135.2	113.5	°C/W
R _{θJB}	Junction-to-board thermal resistance	43	67.6	°C/W
ψ _{JT}	Junction-to-top characterization parameter	19.6	6.7	°C/W
ψ _{JB}	Junction-to-board characterization parameter	42.1	65.9	°C/W

- (1) For more information about traditional and new thermal metrics, see the *Semiconductor and IC Package Thermal Metrics* application report.

6.5 Electrical Characteristics: TL43x-Q1

 over recommended operating conditions, T_A = 25°C (unless otherwise noted)

PARAMETER	TEST CONDITIONS	MIN	TYP	MAX	UNIT
V _{REF}	Reference voltage	V _{KA} = V _{REF} , I _{KA} = 10 mA, see Figure 20			mV
V _{I(DEV)}	Deviation of reference voltage over full temperature ⁽¹⁾	V _{KA} = V _{REF} , I _{KA} = 10 mA, T _A = –40°C to 125°C, see Figure 20			mV
ΔV _{REF} /ΔV _{KA}	Ratio of change in reference voltage to the change in cathode voltage	I _{KA} = 10 mA, see Figure 21	ΔV _{KA} = 10 V – V _{REF}	–1.4	–2.7
			ΔV _{KA} = 36 V – 10 V	–1	–2

- (1) The deviation parameters (V_{I(DEV)} and I_{I(DEV)}) are defined as the differences between the maximum and minimum values obtained over the recommended temperature range.

Electrical Characteristics: TL43x-Q1 (continued)

over recommended operating conditions, $T_A = 25^\circ\text{C}$ (unless otherwise noted)

PARAMETER	TEST CONDITIONS	MIN	TYP	MAX	UNIT
I_{REF}	Reference current		2	4	μA
$I_{I(DEV)}$	Deviation of reference current over full temperature ⁽¹⁾		0.8	2.5	μA
I_{MIN}	Minimum cathode current for regulation		0.4	1	mA
I_{OFF}	OFF-state cathode current		0.1	1	μA
$ Z_{KA} $	Dynamic impedance ⁽¹⁾		0.2	0.5	Ω

6.6 Electrical Characteristics: TL43xA-Q1

over recommended operating conditions, $T_A = 25^\circ\text{C}$ (unless otherwise noted)

PARAMETER	TEST CONDITIONS	MIN	TYP	MAX	UNIT
V_{REF}	Reference voltage	2470	2495	2520	mV
$V_{I(DEV)}$	Deviation of reference voltage over full temperature ⁽¹⁾		14	34	mV
$\Delta V_{REF}/\Delta V_{KA}$	Ratio of change in reference voltage to the change in cathode voltage		-1.4	-2.7	mV/V
I_{REF}	Reference current		2	4	μA
$I_{I(DEV)}$	Deviation of reference current over full temperature ⁽¹⁾		0.8	2.5	μA
I_{MIN}	Minimum cathode current for regulation		0.4	0.7	mA
I_{OFF}	OFF-state cathode current		0.1	0.5	μA
$ Z_{KA} $	Dynamic impedance ⁽¹⁾		0.2	0.5	Ω

(1) The deviation parameters ($V_{I(DEV)}$ and $I_{I(DEV)}$) are defined as the differences between the maximum and minimum values obtained over the recommended temperature range.

6.7 Electrical Characteristics: TL43xB-Q1

over recommended operating conditions, $T_A = 25^\circ\text{C}$ (unless otherwise noted)

PARAMETER	TEST CONDITIONS	MIN	TYP	MAX	UNIT
V_{REF}	Reference voltage	2483	2495	2507	mV
$V_{I(DEV)}$	Deviation of reference voltage over full temperature ⁽¹⁾		14	34	mV
$\Delta V_{REF}/\Delta V_{KA}$	Ratio of change in reference voltage to the change in cathode voltage		-1.4	-2.7	mV/V
I_{REF}	Reference current		2	4	μA
$I_{I(DEV)}$	Deviation of reference current over full temperature ⁽¹⁾		0.8	2.5	μA
I_{MIN}	Minimum cathode current for regulation		0.4	0.7	mA
I_{OFF}	OFF-state cathode current		0.1	0.5	μA
$ Z_{KA} $	Dynamic impedance ⁽¹⁾		0.2	0.5	Ω

(1) The deviation parameters ($V_{I(DEV)}$ and $I_{I(DEV)}$) are defined as the differences between the maximum and minimum values obtained over the recommended temperature range.

6.8 Typical Characteristics

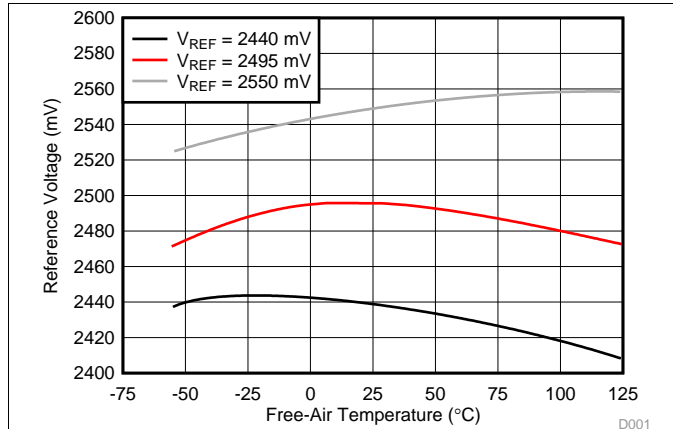

Data is for devices having the indicated value of V_{REF} at $I_{KA} = 10$ mA, $T_A = 25^\circ\text{C}$.

Figure 1. Reference Voltage vs Free-air Temperature

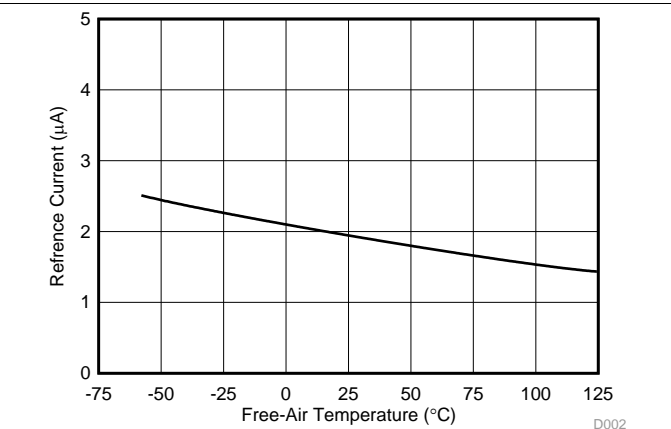

Figure 2. Reference Current vs Free-air Temperature

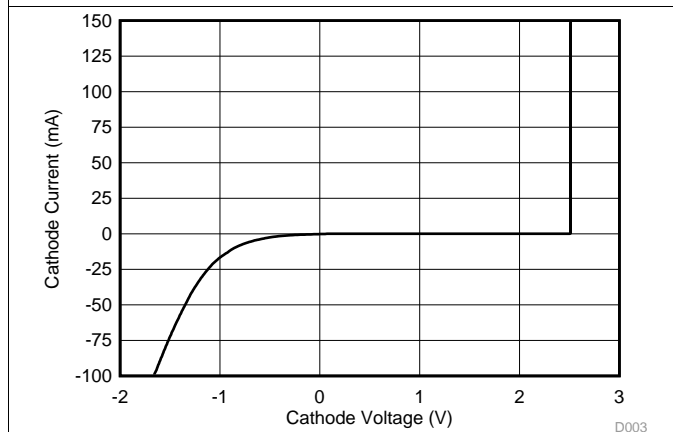

Figure 3. Cathode Current vs Cathode Voltage

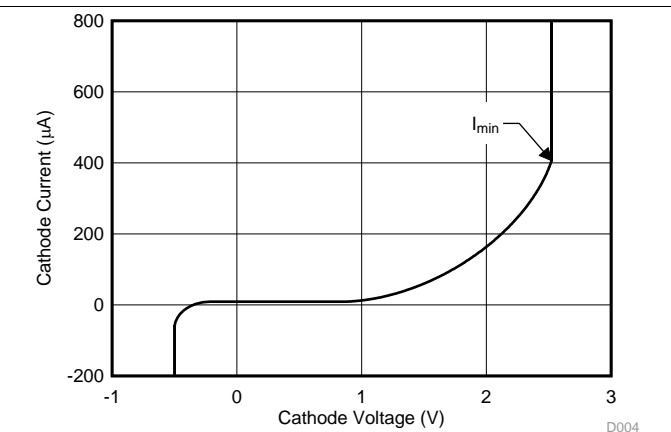

Figure 4. Cathode Current vs Cathode Voltage

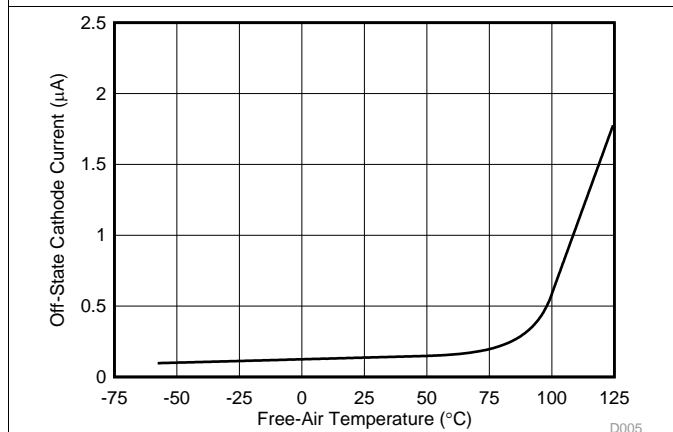

Figure 5. OFF-State Cathode Current vs Free-air Temperature

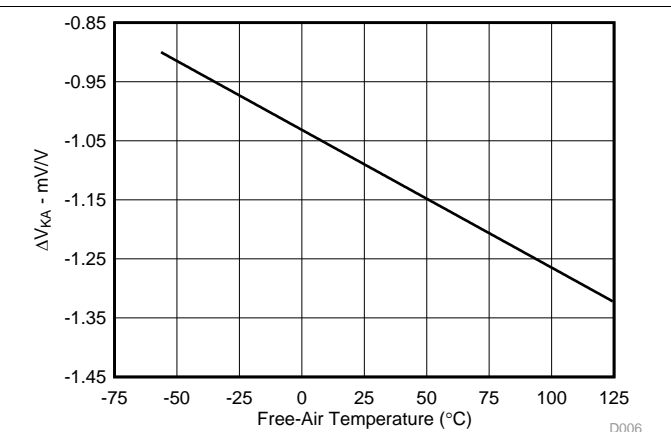

Figure 6. Ratio of Delta Reference Voltage to Delta Cathode Voltage vs Free-air Temperature

Typical Characteristics (continued)

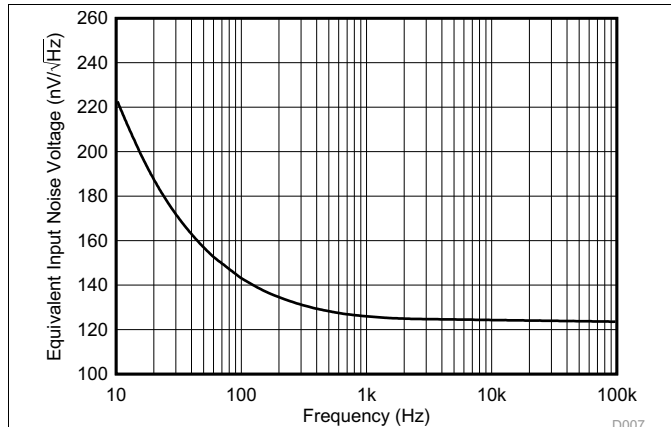

Figure 7. Equivalent Input Noise Voltage vs Frequency

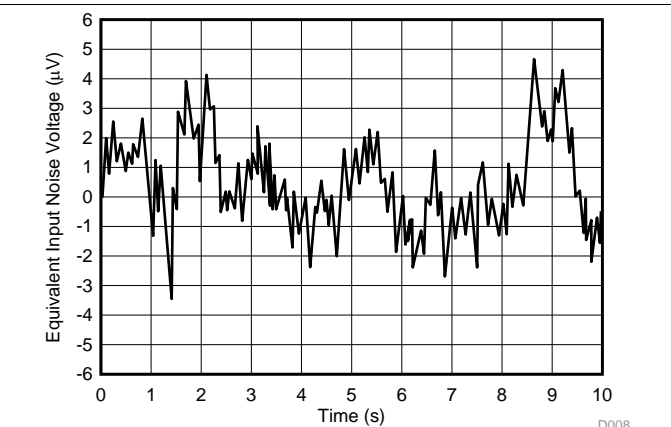

Figure 8. Equivalent Input Noise Voltage Over a 10-s Period

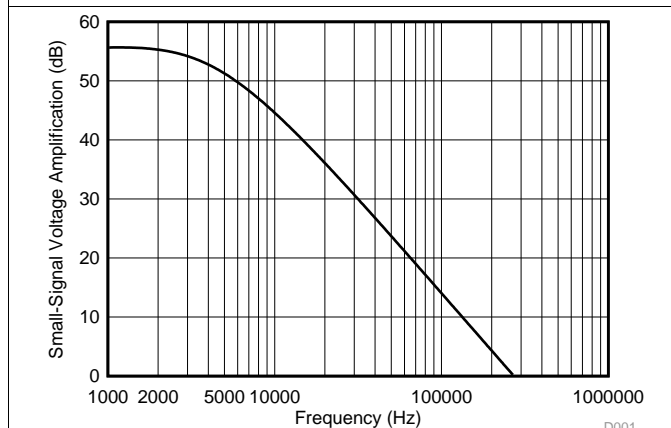

Figure 9. Small-Signal Voltage Amplification vs Frequency

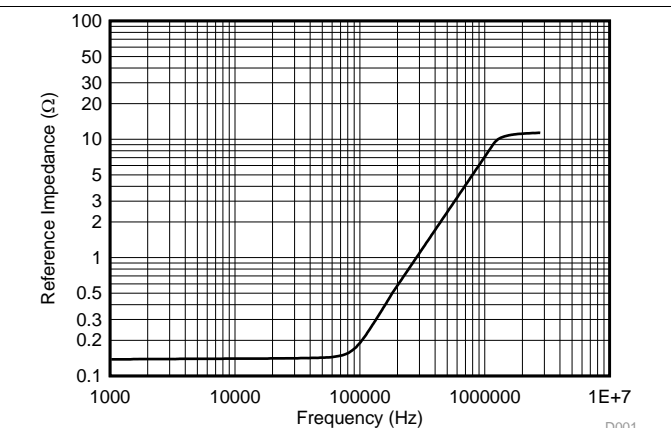

Figure 10. Reference Impedance vs Frequency

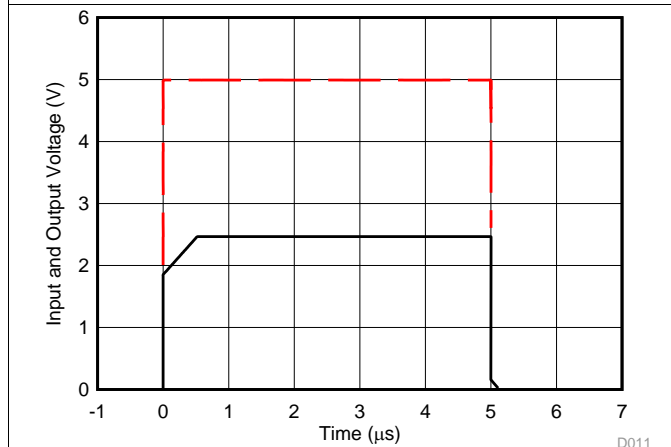
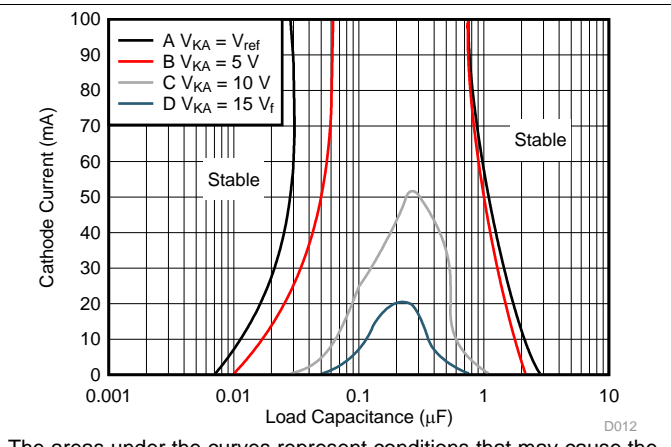
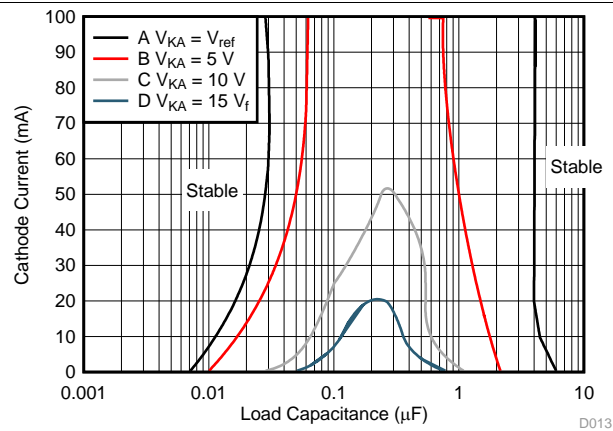

Figure 11. Pulse Response



The areas under the curves represent conditions that may cause the device to oscillate. For curves B, C, and D, R2 and V_{REF} were adjusted to establish the initial V_{KA} and I_{KA} conditions with C_L = 0. V_{BATT} and C_L then were adjusted to determine the ranges of stability (see Figure 18 and Figure 19 for test circuits).

Figure 12. Stability Boundary Conditions for All TL43x Devices (Except for SOT23-3, SC-70, and Q-TEMP Devices)

Typical Characteristics (continued)

The areas under the curves represent conditions that may cause the device to oscillate. For curves B, C, and D, R_2 and V_{REF} were adjusted to establish the initial V_{KA} and I_{KA} conditions with $C_L = 0$. V_{BATT} and C_L then were adjusted to determine the ranges of stability (see [Figure 18](#) and [Figure 19](#) for test circuits).

Figure 13. Stability Boundary Conditions for All TL43x, SOT-23, SC-70, and Q-TEMP Devices

7 Parameter Measurement Information

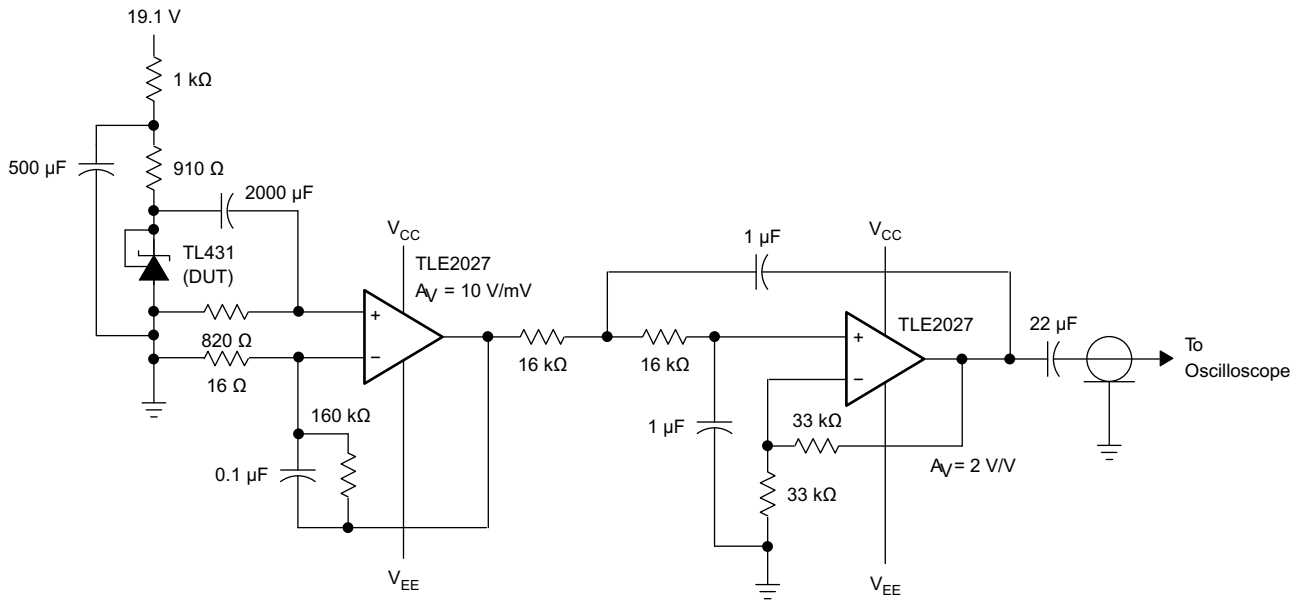

Copyright © 2016, Texas Instruments Incorporated

Figure 14. Test Circuit for Equivalent Input Noise Voltage

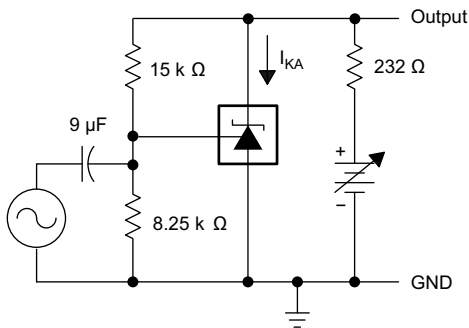

Figure 15. Test Circuit for Voltage Amplification

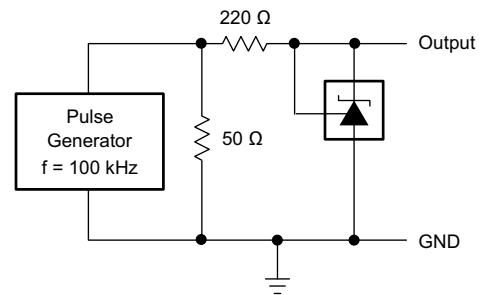

Figure 17. Test Circuit for Pulse Response

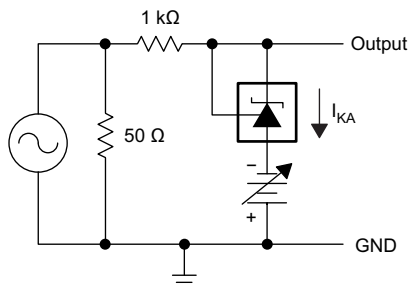

Figure 16. Test Circuit for Reference Impedance

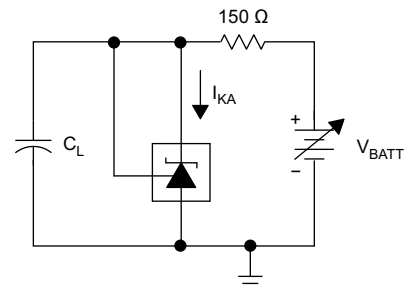

Figure 18. Test Circuit for Curve A

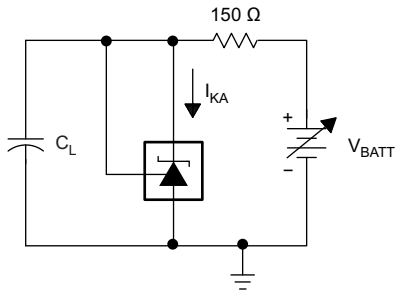

Figure 19. Test Circuit for Curves B, C, and D

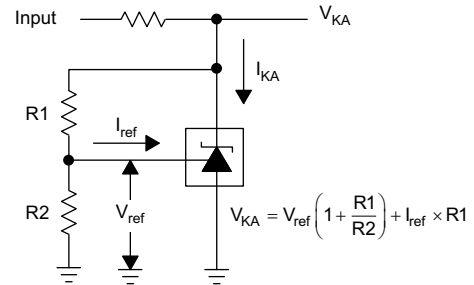

Figure 21. Test Circuit for $V_{KA} > V_{REF}$

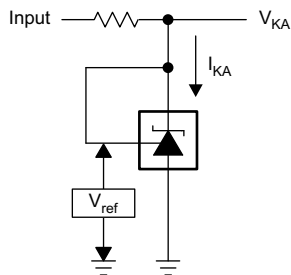

Figure 20. Test Circuit for $V_{KA} = V_{REF}$

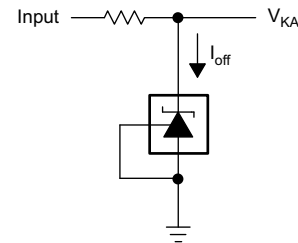

Figure 22. Test Circuit for I_{OFF}

8 Detailed Description

8.1 Overview

This device has proven ubiquity and versatility across a wide range of applications, ranging from power to signal path. This is due to its key components containing an accurate voltage reference and op amp, which are fundamental analog building blocks. The TL43x-Q1 can be used as a single voltage reference, error amplifier, voltage clamp, or comparator with integrated reference.

The TL43x-Q1 can be operated and adjusted to cathode voltages from 2.5 V to 36 V, making this part optimum for a wide range of end equipments in industrial, auto, telecommunications, and computing. For this device to behave as a shunt regulator or error amplifier, at least 1 mA ($I_{MIN(MAX)}$) must be supplied to the cathode pin. Under this condition, feedback can be applied from the CATHODE and REF pins to create a replica of the internal reference voltage.

Various reference voltage options can be purchased with initial tolerances (at 25°C) of 0.5% and 1%. These reference options are denoted by B (0.5%) or A (1%) in the part number (TL431x-Q1).

8.2 Functional Block Diagram

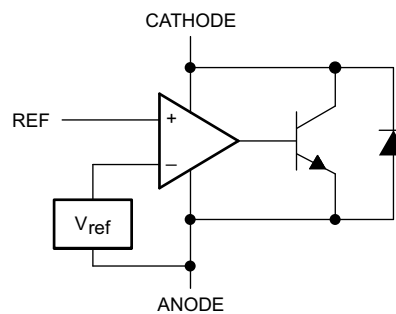

Copyright © 2016, Texas Instruments Incorporated

Figure 23. Equivalent Schematic

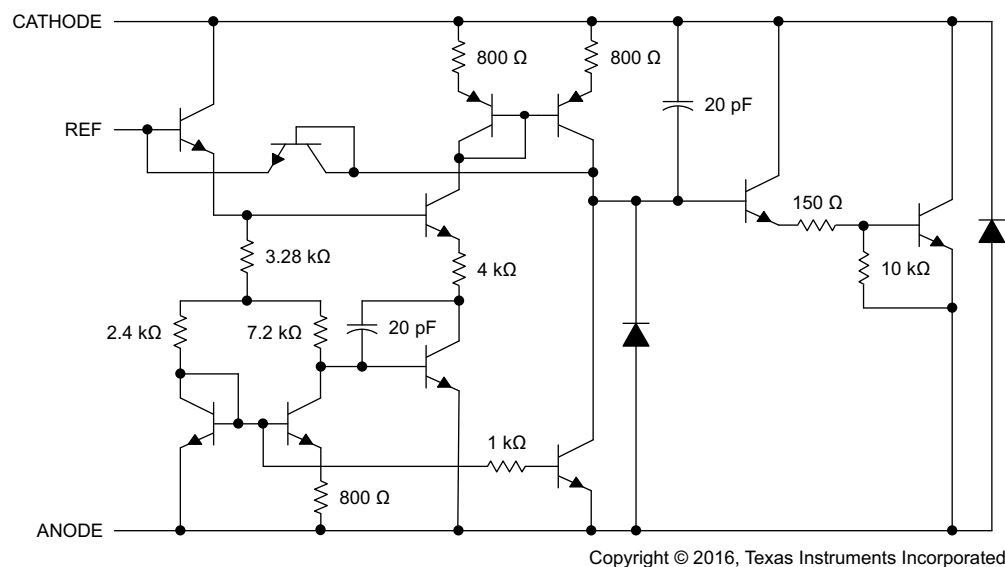

Copyright © 2016, Texas Instruments Incorporated

All component values are nominal.

Figure 24. Detailed Schematic

8.3 Feature Description

The TL43x-Q1 consists of an internal reference and amplifier that outputs a sink current based on the difference between the reference pin and the virtual internal pin. The sink current is produced by the internal Darlington pair, shown in [Figure 24](#). A Darlington pair is used to allow this device to sink a maximum current of 100 mA.

When operated with enough voltage headroom (at least 2.5 V) and cathode current (I_{KA}), the TL43x-Q1 forces the reference pin to 2.5 V. However, the reference pin can not be left floating, as I_{REF} must be at least 4 μ A (see [Specifications](#)). This is because the reference pin is driven into an NPN, which requires base current to operate properly.

When feedback is applied from the CATHODE and REF pins, the TL43x-Q1 behaves as a Zener diode, regulating to a constant voltage dependent on current being supplied into the cathode. This is due to the internal amplifier and reference entering the proper operating regions. The same amount of current required in the above feedback situation must be applied to this device in open loop, servo, or error amplifying implementations for it to be in the proper linear region giving the device enough gain.

Unlike many linear regulators, the TL43x-Q1 is internally compensated to be stable without an output capacitor between the cathode and anode. However, if it is desired to use an output capacitor [Figure 24](#) can be used as a guide to assist in choosing the correct capacitor to maintain stability.

8.4 Device Functional Modes

8.4.1 Open Loop (Comparator)

When the cathode or output voltage or current of the TL43x-Q1 is not being fed back to the reference or input pin in any form, the device operates in open loop. With proper cathode current (I_{KA}) applied to this device, the TL43x-Q1 has the characteristics shown in [Figure 24](#). With such high gain in this configuration, the device is typically used as a comparator. The integrated reference makes TL43x the preferred choice when trying to monitor a certain level of a single signal.

8.4.2 Closed Loop

When the cathode or output voltage or current of the TL43x-Q1 is being fed back to the reference or input pin in any form, the device operates in closed loop. The majority of applications involving the TL43x-Q1 use it in this manner to regulate a fixed voltage or current. The feedback enables this device to behave as an error amplifier, computing a portion of the output voltage and adjusting it to maintain the desired regulation. This is done by relating the output voltage back to the reference pin in a manner to make it equal to the internal reference voltage, which can be accomplished through resistive or direct feedback.

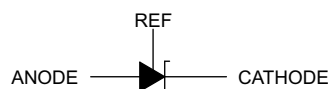

Figure 25. Logic Symbol

9 Application and Implementation

NOTE

Information in the following applications sections is not part of the TI component specification, and TI does not warrant its accuracy or completeness. TI's customers are responsible for determining suitability of components for their purposes. Customers should validate and test their design implementation to confirm system functionality.

9.1 Application Information

As this device has many applications and setups, there are many situations that this data sheet can not characterize in detail. The linked application notes help the make the best choices when using this part.

[Understanding Stability Boundary Conditions Charts in TL431, TL432 Data Sheet](#) provides a deeper understanding of this devices stability characteristics and aid the user in making the right choices when choosing a load capacitor. [Setting the Shunt Voltage on an Adjustable Shunt Regulator](#) assists designers in setting the shunt voltage to achieve optimum accuracy for this device.

9.2 Typical Applications

9.2.1 Comparator Application

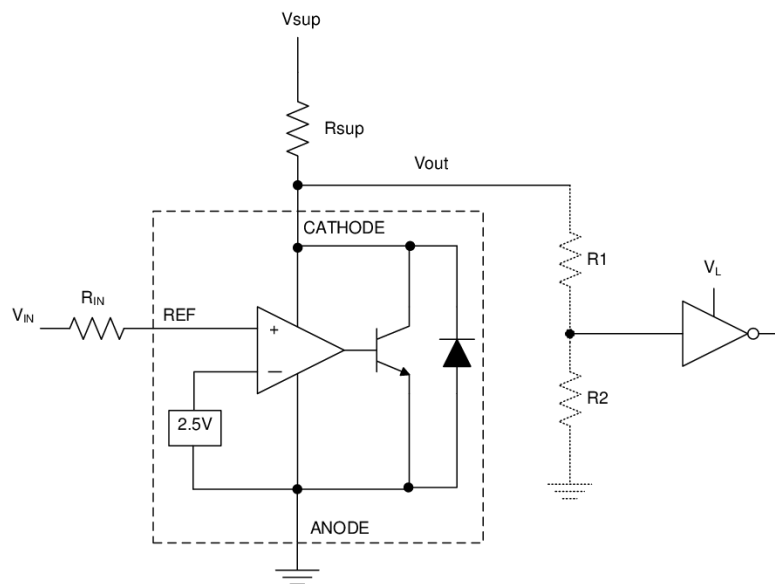

Copyright © 2016, Texas Instruments Incorporated

Figure 26. Comparator Application Schematic

Typical Applications (continued)

9.2.1.1 Design Requirements

For this design example, use the parameters listed in [Table 1](#) as the input parameters.

Table 1. Design Parameters

PARAMETER	VALUE
Input voltage	0 V to 5 V
Input resistance	10 k Ω
Supply voltage	24 V
Cathode current, I_K	5 mA
Output voltage level	Approximately 2 V to V_{SUP}
Logic input thresholds, V_{IH} / V_{IL}	V_L

9.2.1.2 Detailed Design Procedure

When using the TL43x-Q1 as a comparator with reference, determine the following:

- Input voltage range
- Reference voltage accuracy
- Output logic input high and low level thresholds
- Current source resistance

9.2.1.2.1 Basic Operation

In the configuration shown in [Figure 26](#) the TL43x-Q1 behaves as a comparator, comparing the REF pin voltage to the internal virtual reference voltage. When provided a proper cathode current (I_{KA}), the TL43x-Q1 has enough open loop gain to provide a quick response. This is shown in [Figure 27](#), where the $R_{SUP} = 10\text{ k}\Omega$ ($I_{KA} = 500\text{ }\mu\text{A}$) situation responds much slower than $R_{SUP} = 1\text{ k}\Omega$ ($I_{KA} = 5\text{ mA}$). With the TL43x-Q1's maximum operating current (I_{MIN}) being 1 mA, operation below that could result in low gain, leading to a slow response.

9.2.1.2.2 Overdrive

Slow or inaccurate responses can also occur when the reference pin is not provided enough overdrive voltage. This is the amount of voltage that is higher than the internal virtual reference. The internal virtual reference voltage is within the range of $2.5\text{ V} \pm (0.5\%, 1\%, \text{ or } 1.5\%)$ depending on which version is being used. The more overdrive voltage provided, the faster the TL43x-Q1 responds.

For applications where the TL43x-Q1 is being used as a comparator, it is best to set the trip point to greater than the positive expected error (for example: +1% for the A version). For fast response, setting the trip point to at least 10% of the internal V_{REF} should suffice.

For minimal drop or difference from V_{INREF} to the REF pin, TI recommends using an input resistor $<10\text{ k}\Omega$ to provide I_{REF} .

9.2.1.2.3 Output Voltage and Logic Input Level

For the TL43x-Q1 to properly be used as a comparator, the logic output must be readable by the receiving logic device. This is accomplished by knowing the input high and low level threshold voltage levels, typically denoted by V_{IH} and V_{IL} .

As seen in [Figure 26](#), the TL43x-Q1's output low level voltage in open-loop or comparator mode is approximately 2 V, which is typically sufficient for 5-V supplied logic. However, would not work for 3.3-V and 1.8-V supplied logic. To accommodate this a resistive divider can be tied to the output to attenuate the output voltage to a voltage legible to the receiving low voltage logic device.

The TL43x-Q1's output high voltage is equal to V_{SUP} due to the TL43x-Q1 being open-collector. If V_{SUP} is much higher than the receiving logic's maximum input voltage tolerance, the output must be attenuated to accommodate the outgoing logic's reliability.

When using a resistive divider on the output, ensure the sum of the resistive divider ($R1$ and $R2$ in [Figure 24](#)) is much greater than R_{SUP} to not interfere with the TL43x-Q1's ability to pull close to V_{SUP} when turning off.

9.2.1.2.4 Input Resistance

In this application, the TL43x-Q1 requires an input resistance in addition to the reference current (I_{REF}) to ensure the device is in the proper operating regions while turning on. The actual voltage seen at the REF pin is $V_{REF} = V_{IN} - I_{REF} \times R_{IN}$. Because I_{REF} can be as high as $4 \mu A$, TI recommends using a resistance small enough to mitigate the error that I_{REF} creates from V_{IN} .

9.2.1.2.5 Deviation Parameters and Calculating Dynamic Impedance

The deviation parameters, $V_{I(DEV)}$ and $I_{I(DEV)}$, are defined as the differences between the maximum and minimum values obtained over the recommended temperature range. The average full-range temperature coefficient of the reference voltage ($\alpha_{V_{REF}}$) is defined in Equation 1.

$$|\alpha_{V_{REF}}| \frac{\text{ppm}}{^{\circ}\text{C}} = \frac{\left(\frac{V_{I(DEV)}}{V_{REF \text{ at } 25^{\circ}\text{C}}} \right) \times 10^6}{\Delta T_A}$$

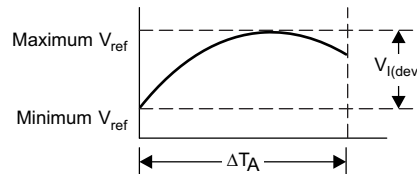

where

- ΔT_A is the recommended operating free-air temperature range of the device (1)

$\alpha_{V_{REF}}$ can be positive or negative, depending on whether minimum V_{REF} or maximum V_{REF} , respectively, occurs at the lower temperature.

Example:

Maximum $V_{REF} = 2496 \text{ mV}$ at 30°C , minimum $V_{REF} = 2492 \text{ mV}$ at 0°C , $V_{REF} = 2495 \text{ mV}$ at 25°C , $\Delta T_A = 70^{\circ}\text{C}$ for TL43x.

$$|\alpha_{V_{REF}}| = \frac{\left(\frac{4 \text{ mV}}{2495 \text{ mV}} \right) \times 10^6}{70^{\circ}\text{C}} \approx \frac{23 \text{ ppm}}{^{\circ}\text{C}} \quad (2)$$

Because minimum V_{REF} occurs at the lower temperature, the coefficient is positive.

The dynamic impedance is defined as $|Z_{KA}| = \Delta V_{KA} / \Delta I_{KA}$.

When the device is operating with two external resistors, see Figure 21, the total dynamic impedance of the circuit is given by Equation 3.

$$|z'| = \frac{\Delta V}{\Delta I} \approx |Z_{KA}| \left(1 + \frac{R1}{R2} \right) \quad (3)$$

9.2.1.3 Application Curve

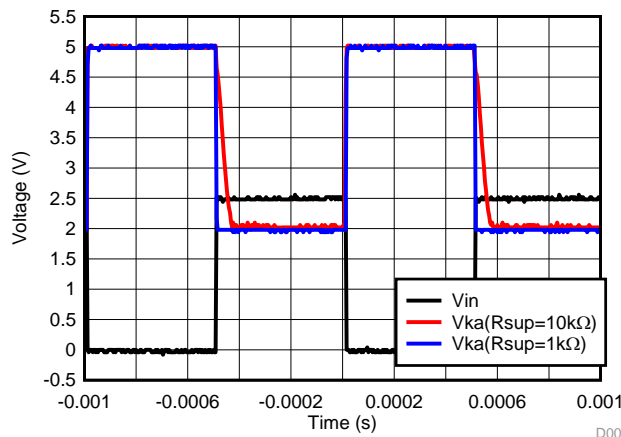
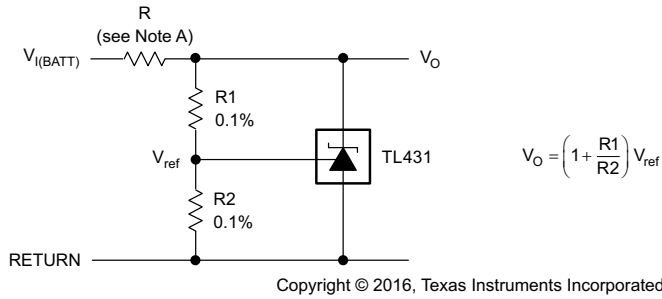

Figure 27. Output Response With Various Cathode Currents

9.2.2 Other Application Circuits

Figure 28 to Figure 40 show application circuit examples using the TL431-Q1 device. Customers must fully validate and test any circuit before implementing a design based on an example in this section. Unless otherwise noted, the design procedures in *Comparator Application* are applicable.



A. R must provide cathode current ≥ 1 mA to the TL431-Q1 at minimum $V_{I(BATT)}$.

Figure 28. Shunt Regulator

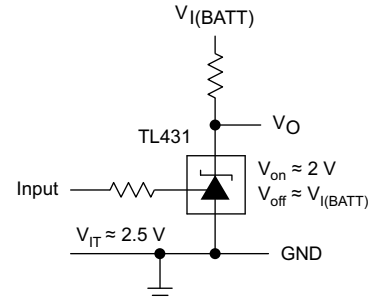
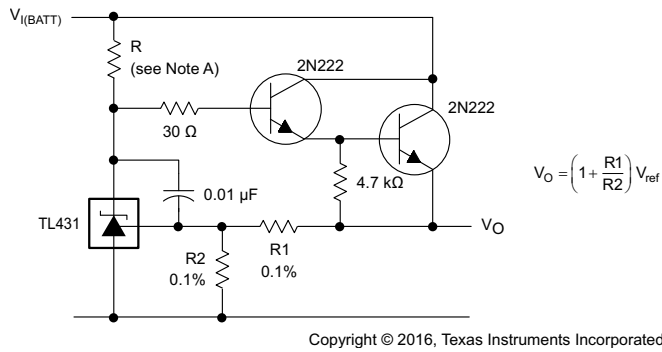

Figure 29. Single-Supply Comparator with Temperature-Compensated Threshold



A. R must provide cathode current ≥ 1 mA to the TL431-Q1 at minimum $V_{I(BATT)}$.

Figure 30. Precision High-Current Series Regulator

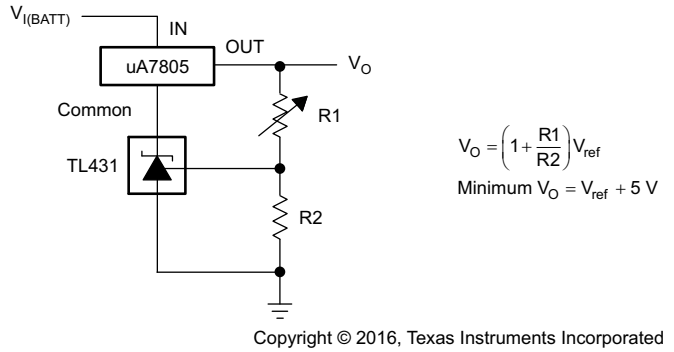

Figure 31. Output Control of a Three-Terminal Fixed Regulator

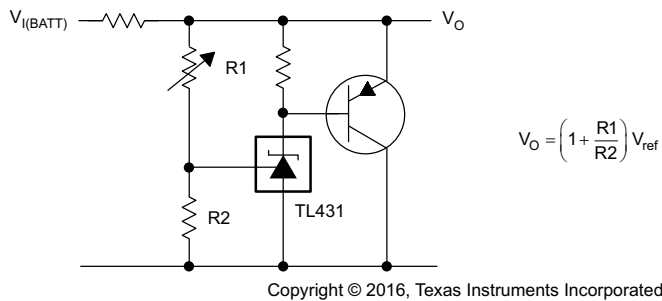
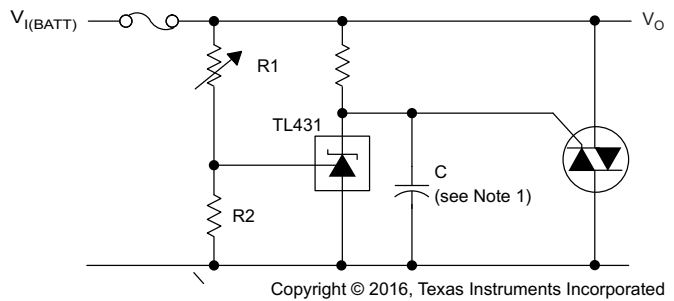
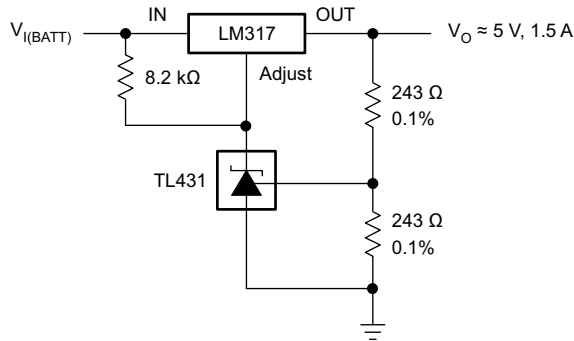

Figure 32. High-Current Shunt Regulator



(1) See Figure 12 and Figure 13 to determine allowable values for C.

Figure 33. Crowbar Circuit



Copyright © 2016, Texas Instruments Incorporated

Figure 34. Precision 5-V, 1.5-A Regulator

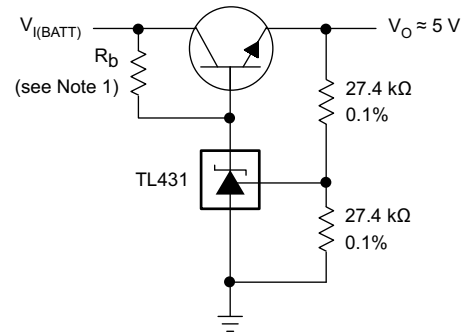

Copyright © 2016, Texas Instruments Incorporated

(1) R_b must provide cathode current ≥ 1 mA to the TL431-Q1.

Figure 35. Efficient 5-V Precision Regulator

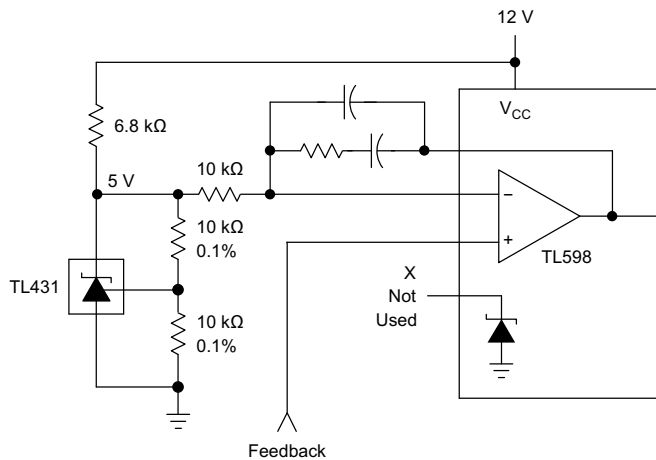

Copyright © 2016, Texas Instruments Incorporated

Figure 36. PWM Converter with Reference

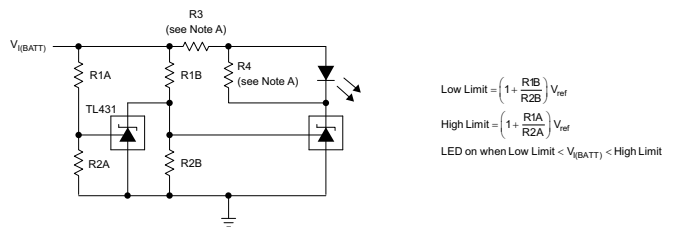

Copyright © 2016, Texas Instruments Incorporated

A. R₃ and R₄ are selected to provide the desired LED intensity and cathode current ≥ 1 mA to the TL431-Q1 at the available V_{I(BATT)}.

Figure 37. Voltage Monitor

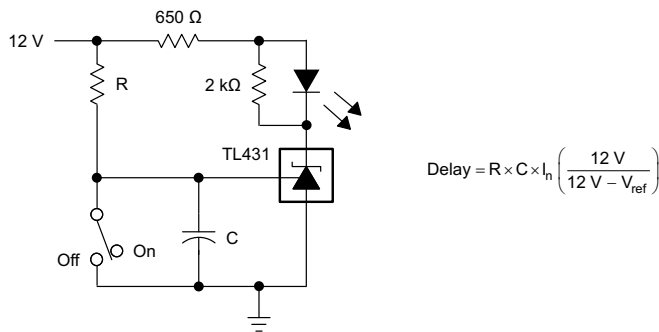

Copyright © 2016, Texas Instruments Incorporated

Figure 38. Delay Timer

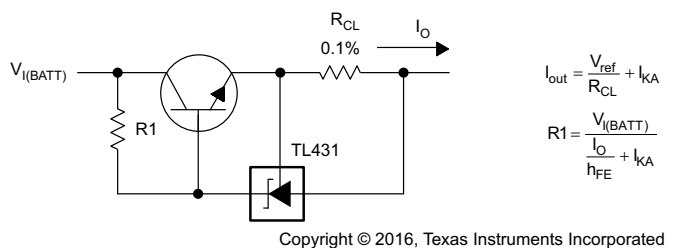

Copyright © 2016, Texas Instruments Incorporated

Figure 39. Precision Current Limiter

$$I_{out} = \frac{V_{ref}}{R_{CL}} + I_{KA}$$

$$R1 = \frac{V_{I(BATT)}}{\frac{I_o}{h_{FE}} + I_{KA}}$$

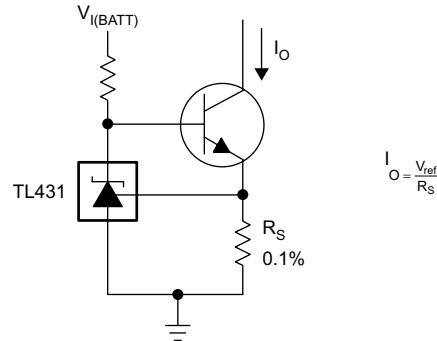

Copyright © 2016, Texas Instruments Incorporated

Figure 40. Precision Constant-Current Sink

10 Power Supply Recommendations

When using the TL43x-Q1 as a linear regulator to supply a load, designers typically use a bypass capacitor on the output or cathode pin. When doing this, be sure that the capacitance is within the stability criteria shown in [Figure 12](#) and [Figure 13](#).

To not exceed the maximum cathode current, be sure that the supply voltage is current limited. Also, be sure to limit the current being driven into the REF pin, as not to exceed its absolute maximum rating.

For applications shunting high currents, pay attention to the cathode and anode trace lengths, adjusting the width of the traces to have the proper current density.

11 Layout

11.1 Layout Guidelines

Bypass capacitors must be placed as close to the device as possible. Current-carrying traces must have widths appropriate for the amount of current they are carrying; in the case of the TL43x-Q1, these currents are low.

11.2 Layout Example

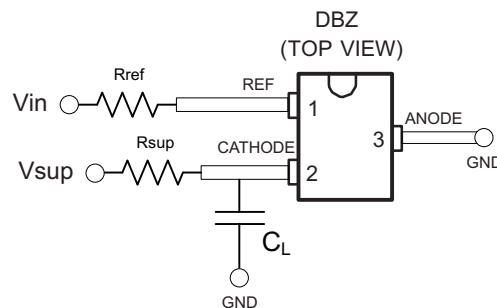
Figure 41. DBZ Layout Example

12 Device and Documentation Support

12.1 Documentation Support

12.1.1 Related Documentation

For related documentation see the following:

- [Automotive LED Lighting with Adjustable Shunt References](#)
- [Understanding Stability Boundary Conditions Charts in TL431, TL432 Data Sheet](#)
- [Setting the Shunt Voltage on an Adjustable Shunt Regulator](#)

12.2 Related Links

The table below lists quick access links. Categories include technical documents, support and community resources, tools and software, and quick access to sample or buy.

Table 2. Related Links

PARTS	PRODUCT FOLDER	SAMPLE & BUY	TECHNICAL DOCUMENTS	TOOLS & SOFTWARE	SUPPORT & COMMUNITY
TL431-Q1	Click here	Click here	Click here	Click here	Click here
TL432-Q1	Click here	Click here	Click here	Click here	Click here
TL431LI-Q1	Click here	Click here	Click here	Click here	Click here
TL432LI-Q1	Click here	Click here	Click here	Click here	Click here

12.3 Receiving Notification of Documentation Updates

To receive notification of documentation updates, navigate to the device product folder on ti.com. In the upper right corner, click on *Alert me* to register and receive a weekly digest of any product information that has changed. For change details, review the revision history included in any revised document.

12.4 Community Resources

The following links connect to TI community resources. Linked contents are provided "AS IS" by the respective contributors. They do not constitute TI specifications and do not necessarily reflect TI's views; see TI's [Terms of Use](#).

TI E2E™ Online Community *TI's Engineer-to-Engineer (E2E) Community*. Created to foster collaboration among engineers. At e2e.ti.com, you can ask questions, share knowledge, explore ideas and help solve problems with fellow engineers.

Design Support *TI's Design Support* Quickly find helpful E2E forums along with design support tools and contact information for technical support.

12.5 Trademarks

E2E is a trademark of Texas Instruments.

All other trademarks are the property of their respective owners.

12.6 Electrostatic Discharge Caution



This integrated circuit can be damaged by ESD. Texas Instruments recommends that all integrated circuits be handled with appropriate precautions. Failure to observe proper handling and installation procedures can cause damage.

ESD damage can range from subtle performance degradation to complete device failure. Precision integrated circuits may be more susceptible to damage because very small parametric changes could cause the device not to meet its published specifications.

12.7 Glossary

SLYZ022 — *TI Glossary*.

This glossary lists and explains terms, acronyms, and definitions.

13 Mechanical, Packaging, and Orderable Information

The following pages include mechanical, packaging, and orderable information. This information is the most current data available for the designated devices. This data is subject to change without notice and revision of this document. For browser-based versions of this data sheet, refer to the left-hand navigation.

PACKAGING INFORMATION

Orderable Device	Status (1)	Package Type	Package Drawing	Pins	Package Qty	Eco Plan (2)	Lead/Ball Finish (6)	MSL Peak Temp (3)	Op Temp (°C)	Device Marking (4/5)	Samples
TL431AQDBVRQ1	ACTIVE	SOT-23	DBV	5	3000	Green (RoHS & no Sb/Br)	NIPDAU	Level-1-260C-UNLIM	-40 to 125	TACQ	Samples
TL431AQDBZRQ1	ACTIVE	SOT-23	DBZ	3	3000	Green (RoHS & no Sb/Br)	NIPDAU	Level-1-260C-UNLIM	-40 to 125	TAQU	Samples
TL431BQDBZRQ1	ACTIVE	SOT-23	DBZ	3	3000	Green (RoHS & no Sb/Br)	NIPDAU	Level-1-260C-UNLIM	-40 to 125	T3FU	Samples
TL432AQDBZRQ1	ACTIVE	SOT-23	DBZ	3	3000	Green (RoHS & no Sb/Br)	NIPDAU	Level-1-260C-UNLIM	-40 to 125	TOIQ	Samples
TL432BQDBZRQ1	ACTIVE	SOT-23	DBZ	3	3000	Green (RoHS & no Sb/Br)	NIPDAU	Level-1-260C-UNLIM	-40 to 125	TOHQ	Samples

(1) The marketing status values are defined as follows:

ACTIVE: Product device recommended for new designs.

LIFEBUY: TI has announced that the device will be discontinued, and a lifetime-buy period is in effect.

NRND: Not recommended for new designs. Device is in production to support existing customers, but TI does not recommend using this part in a new design.

PREVIEW: Device has been announced but is not in production. Samples may or may not be available.

OBSOLETE: TI has discontinued the production of the device.

(2) **RoHS:** TI defines "RoHS" to mean semiconductor products that are compliant with the current EU RoHS requirements for all 10 RoHS substances, including the requirement that RoHS substance do not exceed 0.1% by weight in homogeneous materials. Where designed to be soldered at high temperatures, "RoHS" products are suitable for use in specified lead-free processes. TI may reference these types of products as "Pb-Free".

RoHS Exempt: TI defines "RoHS Exempt" to mean products that contain lead but are compliant with EU RoHS pursuant to a specific EU RoHS exemption.

Green: TI defines "Green" to mean the content of Chlorine (Cl) and Bromine (Br) based flame retardants meet JS709B low halogen requirements of <=1000ppm threshold. Antimony trioxide based flame retardants must also meet the <=1000ppm threshold requirement.

(3) MSL, Peak Temp. - The Moisture Sensitivity Level rating according to the JEDEC industry standard classifications, and peak solder temperature.

(4) There may be additional marking, which relates to the logo, the lot trace code information, or the environmental category on the device.

(5) Multiple Device Markings will be inside parentheses. Only one Device Marking contained in parentheses and separated by a "-" will appear on a device. If a line is indented then it is a continuation of the previous line and the two combined represent the entire Device Marking for that device.

(6) Lead/Ball Finish - Orderable Devices may have multiple material finish options. Finish options are separated by a vertical ruled line. Lead/Ball Finish values may wrap to two lines if the finish value exceeds the maximum column width.

Important Information and Disclaimer: The information provided on this page represents TI's knowledge and belief as of the date that it is provided. TI bases its knowledge and belief on information provided by third parties, and makes no representation or warranty as to the accuracy of such information. Efforts are underway to better integrate information from third parties. TI has taken and continues to take reasonable steps to provide representative and accurate information but may not have conducted destructive testing or chemical analysis on incoming materials and chemicals. TI and TI suppliers consider certain information to be proprietary, and thus CAS numbers and other limited information may not be available for release.

In no event shall TI's liability arising out of such information exceed the total purchase price of the TI part(s) at issue in this document sold by TI to Customer on an annual basis.

OTHER QUALIFIED VERSIONS OF TL431-Q1, TL432-Q1 :

- Catalog: [TL431](#), [TL432](#)

NOTE: Qualified Version Definitions:

- Catalog - TI's standard catalog product

TAPE AND REEL INFORMATION

QUADRANT ASSIGNMENTS FOR PIN 1 ORIENTATION IN TAPE

*All dimensions are nominal

Device	Package Type	Package Drawing	Pins	SPQ	Reel Diameter (mm)	Reel Width W1 (mm)	A0 (mm)	B0 (mm)	K0 (mm)	P1 (mm)	W (mm)	Pin1 Quadrant
TL431AQDBVRQ1	SOT-23	DBV	5	3000	180.0	8.4	3.2	3.2	1.4	4.0	8.0	Q3
TL431AQDBZRQ1	SOT-23	DBZ	3	3000	179.0	8.4	3.15	2.95	1.22	4.0	8.0	Q3
TL431BQDBZRQ1	SOT-23	DBZ	3	3000	179.0	8.4	3.15	2.95	1.22	4.0	8.0	Q3
TL432AQDBZRQ1	SOT-23	DBZ	3	3000	180.0	8.4	3.15	2.95	1.22	4.0	8.0	Q3
TL432BQDBZRQ1	SOT-23	DBZ	3	3000	179.0	8.4	3.15	2.95	1.22	4.0	8.0	Q3

TAPE AND REEL BOX DIMENSIONS

*All dimensions are nominal

Device	Package Type	Package Drawing	Pins	SPQ	Length (mm)	Width (mm)	Height (mm)
TL431AQDBVRQ1	SOT-23	DBV	5	3000	203.0	203.0	35.0
TL431AQDBZRQ1	SOT-23	DBZ	3	3000	203.0	203.0	35.0
TL431BQDBZRQ1	SOT-23	DBZ	3	3000	203.0	203.0	35.0
TL432AQDBZRQ1	SOT-23	DBZ	3	3000	203.0	203.0	35.0
TL432BQDBZRQ1	SOT-23	DBZ	3	3000	203.0	203.0	35.0

DBV0005A



PACKAGE OUTLINE

SOT-23 - 1.45 mm max height

SMALL OUTLINE TRANSISTOR

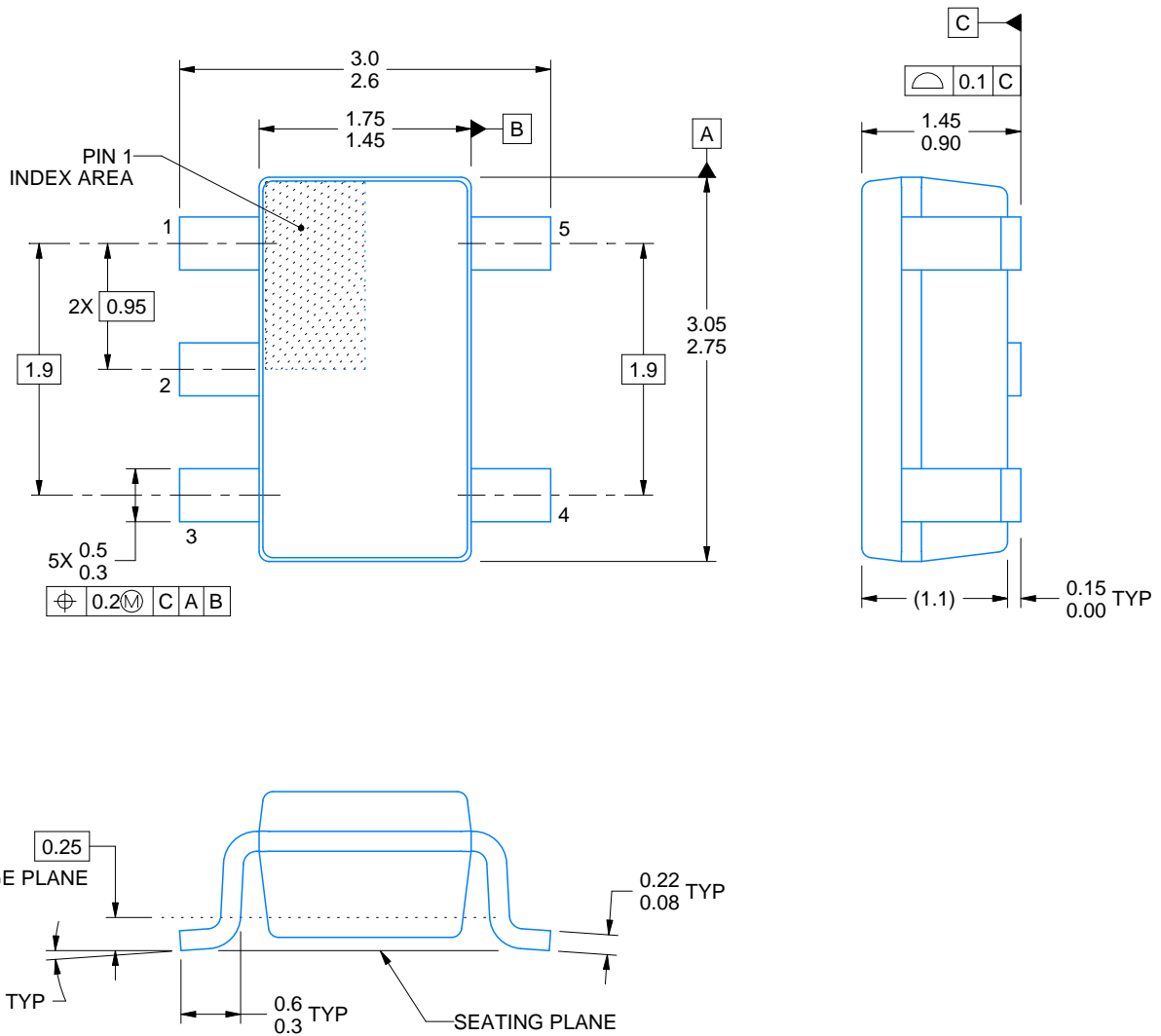

4214839/E 09/2019

NOTES:

1. All linear dimensions are in millimeters. Any dimensions in parenthesis are for reference only. Dimensioning and tolerancing per ASME Y14.5M.
2. This drawing is subject to change without notice.
3. Reference JEDEC MO-178.
4. Body dimensions do not include mold flash, protrusions, or gate burrs. Mold flash, protrusions, or gate burrs shall not exceed 0.15 mm per side.

EXAMPLE BOARD LAYOUT

DBV0005A

SOT-23 - 1.45 mm max height

SMALL OUTLINE TRANSISTOR



LAND PATTERN EXAMPLE
EXPOSED METAL SHOWN
SCALE:15X

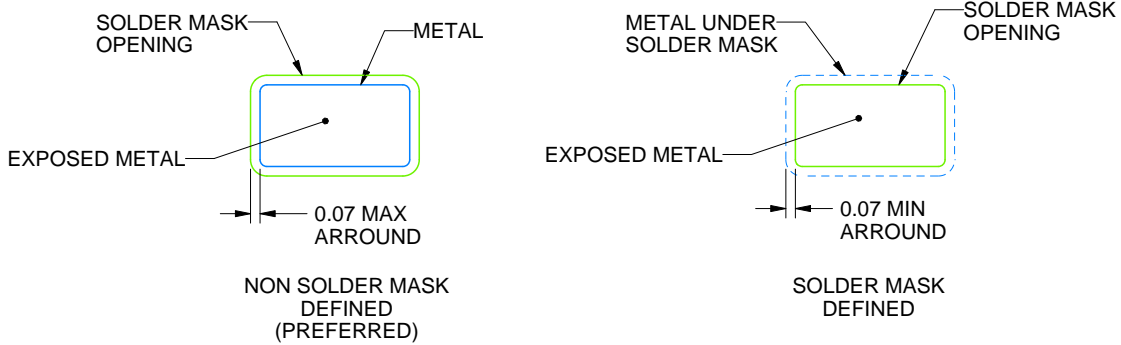

SOLDER MASK DETAILS

4214839/E 09/2019

NOTES: (continued)

- 5. Publication IPC-7351 may have alternate designs.
- 6. Solder mask tolerances between and around signal pads can vary based on board fabrication site.

EXAMPLE STENCIL DESIGN

DBV0005A

SOT-23 - 1.45 mm max height

SMALL OUTLINE TRANSISTOR



SOLDER PASTE EXAMPLE
BASED ON 0.125 mm THICK STENCIL
SCALE:15X

4214839/E 09/2019

NOTES: (continued)

7. Laser cutting apertures with trapezoidal walls and rounded corners may offer better paste release. IPC-7525 may have alternate design recommendations.
8. Board assembly site may have different recommendations for stencil design.

GENERIC PACKAGE VIEW

DBZ 3

SOT-23 - 1.12 mm max height

SMALL OUTLINE TRANSISTOR

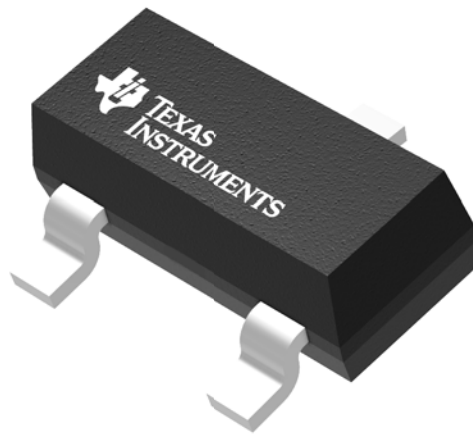

Images above are just a representation of the package family, actual package may vary.
Refer to the product data sheet for package details.

4203227/C

DBZ0003A

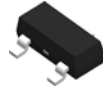

PACKAGE OUTLINE

SOT-23 - 1.12 mm max height

SMALL OUTLINE TRANSISTOR

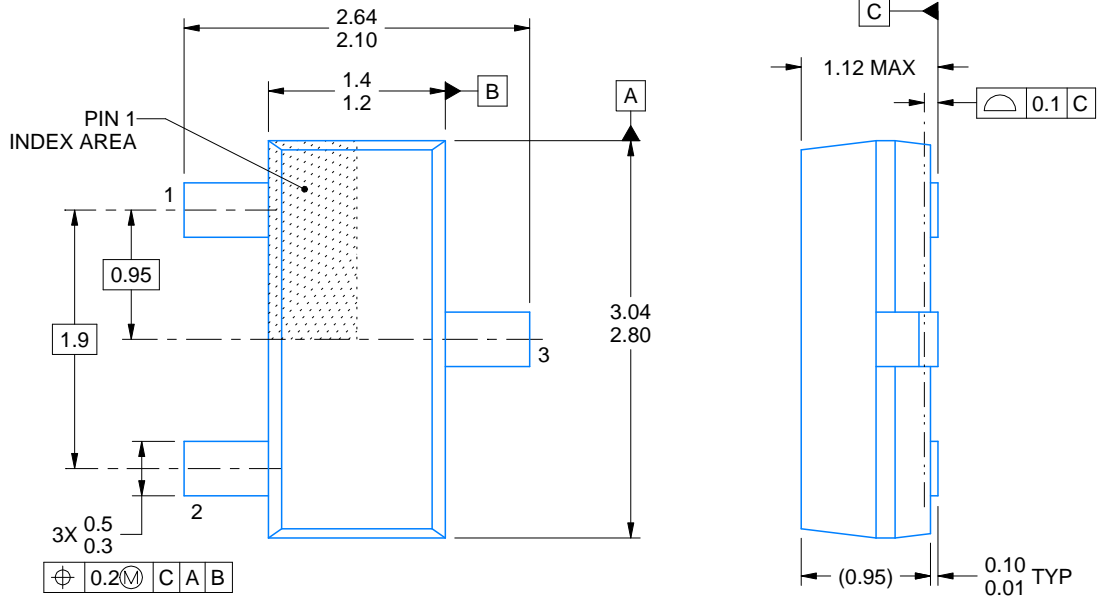

4214838/C 04/2017

NOTES:

1. All linear dimensions are in millimeters. Any dimensions in parenthesis are for reference only. Dimensioning and tolerancing per ASME Y14.5M.
2. This drawing is subject to change without notice.
3. Reference JEDEC registration TO-236, except minimum foot length.

EXAMPLE BOARD LAYOUT

DBZ0003A

SOT-23 - 1.12 mm max height

SMALL OUTLINE TRANSISTOR

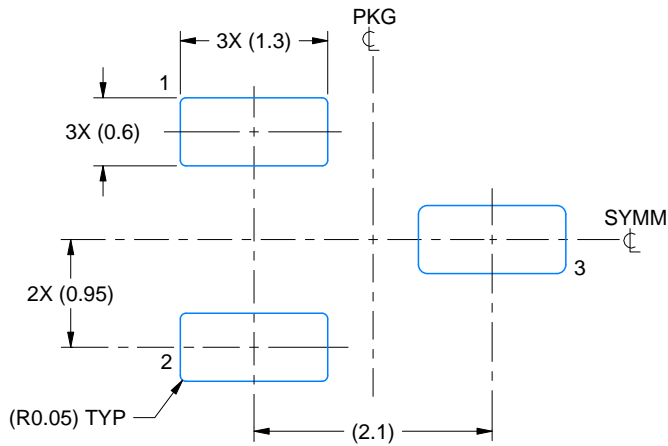

LAND PATTERN EXAMPLE
SCALE:15X

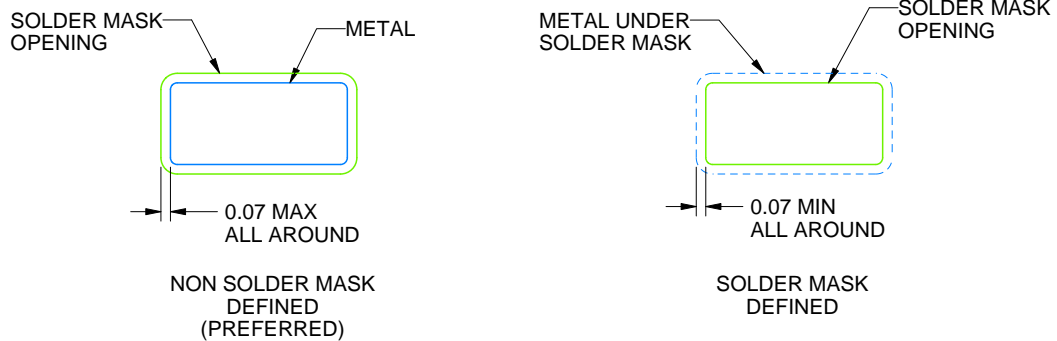

SOLDER MASK DETAILS

4214838/C 04/2017

NOTES: (continued)

4. Publication IPC-7351 may have alternate designs.
5. Solder mask tolerances between and around signal pads can vary based on board fabrication site.

EXAMPLE STENCIL DESIGN

DBZ0003A

SOT-23 - 1.12 mm max height

SMALL OUTLINE TRANSISTOR

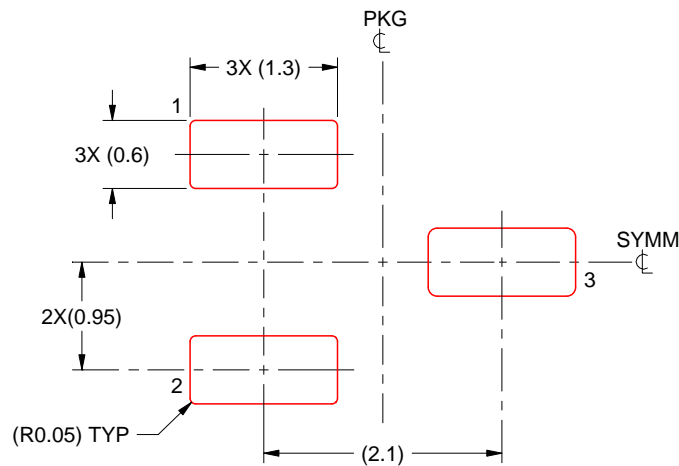

SOLDER PASTE EXAMPLE
BASED ON 0.125 THICK STENCIL
SCALE:15X

4214838/C 04/2017

NOTES: (continued)

6. Laser cutting apertures with trapezoidal walls and rounded corners may offer better paste release. IPC-7525 may have alternate design recommendations.
7. Board assembly site may have different recommendations for stencil design.

IMPORTANT NOTICE AND DISCLAIMER

TI PROVIDES TECHNICAL AND RELIABILITY DATA (INCLUDING DATASHEETS), DESIGN RESOURCES (INCLUDING REFERENCE DESIGNS), APPLICATION OR OTHER DESIGN ADVICE, WEB TOOLS, SAFETY INFORMATION, AND OTHER RESOURCES "AS IS" AND WITH ALL FAULTS, AND DISCLAIMS ALL WARRANTIES, EXPRESS AND IMPLIED, INCLUDING WITHOUT LIMITATION ANY IMPLIED WARRANTIES OF MERCHANTABILITY, FITNESS FOR A PARTICULAR PURPOSE OR NON-INFRINGEMENT OF THIRD PARTY INTELLECTUAL PROPERTY RIGHTS.

These resources are intended for skilled developers designing with TI products. You are solely responsible for (1) selecting the appropriate TI products for your application, (2) designing, validating and testing your application, and (3) ensuring your application meets applicable standards, and any other safety, security, or other requirements. These resources are subject to change without notice. TI grants you permission to use these resources only for development of an application that uses the TI products described in the resource. Other reproduction and display of these resources is prohibited. No license is granted to any other TI intellectual property right or to any third party intellectual property right. TI disclaims responsibility for, and you will fully indemnify TI and its representatives against, any claims, damages, costs, losses, and liabilities arising out of your use of these resources.

TI's products are provided subject to TI's Terms of Sale (www.ti.com/legal/termsofsale.html) or other applicable terms available either on ti.com or provided in conjunction with such TI products. TI's provision of these resources does not expand or otherwise alter TI's applicable warranties or warranty disclaimers for TI products.

Mailing Address: Texas Instruments, Post Office Box 655303, Dallas, Texas 75265
Copyright © 2020, Texas Instruments Incorporated