

# J-CAP Series



## Highest Joules/cc Tantalum Solid Electrolytic Chip Capacitors with Conductive Polymer Electrode



### FEATURES

- Highest Energy per volume
- Conductive polymer electrode offers benign failure mode under recommended use conditions
- Low ESR
- Undertab terminations layout:
  - High Volumetric Efficiency
  - Low profile case sizes
  - High capacitance in smaller dimensions
  - Close positioning of several parts for efficient high density PCB layout
- 3x reflow 260°C compatible



### APPLICATIONS

- Power backup for SSDs (MLC, SLC, EFD, PCIe), battery-powered portable equipment, industrial alarms, smart power meters, and mobile devices.

### CASE DIMENSIONS: millimeters (inches)

Code	EIA Code	EIA Metric	L±0.20 (0.008)	W+0.20 (0.008) -0.10 (0.004)	H max.	W <sub>P</sub> +0.50 (0.020) -0.10 (0.004)	W <sub>T</sub> ±0.20 (0.008)	A <sub>P</sub> +0.30 (0.012) -0.20 (0.008)	A <sub>T</sub> +0.30 (0.012) -0.20 (0.008)
L	1210	3528-10	3.50 (0.138)	2.80 (0.110)	1.00 (0.039)	2.10 (0.083)	2.10 (0.083)	1.15 (0.045)	1.35 (0.053)
T	1210	3528-12	3.50 (0.138)	2.80 (0.110)	1.20 (0.047)	2.10 (0.083)	2.10 (0.083)	1.15 (0.045)	1.35 (0.053)
X	2917	7343-15	7.30 (0.287)	4.30 (0.169)	1.50 (0.059)	3.25 ± 0.20 (0.128±0.008)	3.25 (0.128)	2.00 (0.079)	3.20 (0.126)

Code	EIA Code	EIA Metric	L±0.30 (0.012)	W±0.30 (0.012)	H max.	W <sub>T</sub> ±0.20 (0.008)	-	A <sub>P</sub> +0.30 (0.012) -0.20 (0.008)	A <sub>T</sub> +0.30 (0.012) -0.20 (0.008)
3	2924	7361-15	7.30 (0.287)	6.00 (0.240)	1.50 (0.059)	4.75 (0.187)	-	2.00 (0.079)	3.20 (0.126)
4	2924	7361-20	7.30 (0.287)	6.00 (0.240)	2.00 (0.079)	4.75 (0.187)	-	2.00 (0.079)	3.20 (0.126)

W<sub>T</sub> dimension applies to the termination width for A dimensional area only.

Under development

### MARKING

#### 4, X CASE

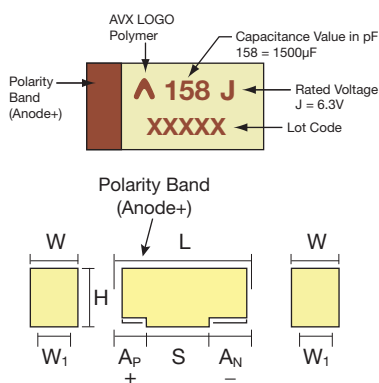

#### L, T CASE

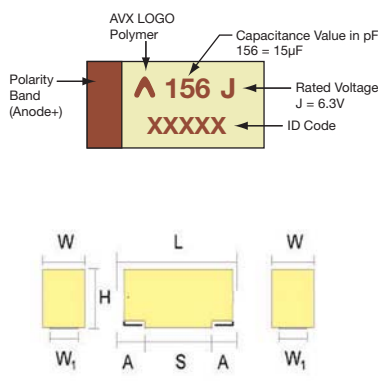

### MAXIMUM ENERGY PER CASE SIZE

Case Size	Approved (mJ)	Under development (mJ)
L	3.3	4.7
T	4.7	6.5
X	14.9	18.2
3	-	38.8
4	32.7	38.8

### HOW TO ORDER

TCN	4	158	M	006	R	0055
Type	Case Size See table above	Capacitance Code pF code: 1st two digits represent significant figures, 3rd digit represents multiplier (number of zeros to follow)	Tolerance M = ±20%	Rated DC Voltage 006 = 6.3Vdc 016 = 16Vdc 025 = 25Vdc 035 = 35Vdc 050 = 50Vdc	Packaging R = Pure Tin 7" Reel	ESR in mΩ



# J-CAP Series



## Highest Joules/cc Tantalum Solid Electrolytic Chip Capacitors with Conductive Polymer Electrode

### TECHNICAL SPECIFICATIONS

Technical Data:	All technical data relate to an ambient temperature of +25°C						
Capacitance Range:	4.7 $\mu$ F to 1500 $\mu$ F						
Capacitance Tolerance:	$\pm$ 20%						
Leakage Current DCL:	0.1CV						
Rated Voltage ( $V_R$ )	$\leq$ +85°C:	6.3	16	25	35	50	
Surge Voltage ( $V_S$ )	$\leq$ +85°C:	8	21	33	46	65	
Temperature Range:	-55°C to +105°C						
Reliability:	1% per 1000 hours at 85°C, $V_R$ with 0.1 $\Omega$ /V series impedance 60% confidence level						

### CAPACITANCE AND RATED VOLTAGE RANGE (LETTER DENOTES CASE SIZE)

Capacitance		Rated Voltage DC to 85°C, [mJ]				
$\mu$ F	Code	6.3V (J)	16V (C)	25V (E)	35V (V)	50V (T)
4.7	475				T(200) [1.8]	
10	106				T(200) [3.9]	
22	226			T(200)* [4.3]		
33	336		L(200)/T(200) [3.3]	T(250)* [6.5]		4(200)* [26.3]
47	476		L(200)*/T(200) [4.7]	X(100) [9.2]	X(100)* [18.2]	
100	107	L(200) [1.2]		3(70)* [19.6]	4(150)* [38.8] 3(150)*	
150	157	L(200)/T(200) [1.7]	X(70) [14.9]	4(70)* [29.3]		
220	227	T(200)* [2.6]	4(70) [21.8]			
330	337		4(70) [32.7]			
470	477	X(50) [5.4]				
1000	108	3(100)* [11.6] X(200)/4(55)				
1500	158	4(55) [17.4]				

Available Ratings, (ESR ratings in mOhms in brackets) [Energy in mJ]

Engineering samples - please contact manufacturer

\*Codes under development - subject to change

Note: Voltage ratings are minimum values. AVX reserves the right to supply higher ratings in the same case size, to the same reliability standards.

# J-CAP Series



## Highest Joules/cc Tantalum Solid Electrolytic Chip Capacitors with Conductive Polymer Electrode

### RATINGS & PART NUMBER REFERENCE

AVX Part No.	Case Size	Cap (µF)	Rated Voltage (V)	Rated Temp. (°C)	Category Voltage (V)	Product Category	DCL (µA) Max.	DF % Max.	ESR Max. (mΩ) @ 100kHz	MSL	ENERGY		
											Energy (mJ)	Energy/volume (mJ/cm³)	Energy/area (mJ/cm²)
<b>6.3 Volt @ 85°C</b>													
TCNL107M006#0200	L	100	6.3	85	5	105°C	60	10	200	3	1.2	118	11.8
TCNL157M006#0200	L	150	6.3	85	5	105°C	90	10	200	3	1.7	177	17.7
TCNT157M006#0200	T	150	6.3	85	5	105°C	90	10	200	3	1.7	147	17.7
TCNT227M006#0200	T	220	6.3	85	5	105°C	132	10	200	3	2.6	216	26.0
TCNX477M006#0050	X	470	6.3	85	6.3	85°C	282	6	50	3	5.4	116	17.3
TCNX108M006#0200	X	1000	6.3	85	6.3	85°C	600	30	200	3	11.6	246	36.9
TCN3108M006#0100	3	1000	6.3	85	6.3	85°C	600	20	100	4	11.6	176	26.4
TCN4108M006#0055	4	1000	6.3	85	6.3	85°C	600	20	55	4	11.6	127	26.4
TCN4158M006#0055	4	1500	6.3	85	6.3	85°C	900	20	55	4	17.4	190	39.6
<b>16 Volt @ 85°C</b>													
TCNL336M016#0200	L	33	16	85	16	85°C	52.8	6	200	3	3.3	334	33.4
TCNT336M016#0200	T	33	16	85	16	85°C	52.8	6	200	3	3.3	277	33.4
TCNL476M016#0200	L	47	16	85	16	85°C	75.2	6	200	3	4.7	476	47.6
TCNT476M016#0200	T	47	16	85	16	85°C	75.2	6	200	3	4.7	395	47.6
TCNX157M016#0070	X	150	16	85	16	85°C	240	6	70	3	14.9	316	47.4
TCN4227M016#0070	4	220	16	105	16	105°C	352	20	70	4	21.8	239	49.8
TCN4337M016#0070	4	330	16	85	16	85°C	528	20	70	3	32.7	359	74.7
<b>25 Volt @ 85°C</b>													
TCNT226M025#0200	T	22	25	85	25	85°C	55	10	200	3	4.3	364	43.9
TCNT336M025#0250	T	33	25	85	25	85°C	82.5	10	250	3	6.5	547	65.8
TCNX476M025#0100	X	47	25	105	25	105°C	117.5	6	100	3	9.2	195	29.3
TCN3107M025#0070	3	100	25	85	25	85°C	250	20	70	4	19.6	298	44.6
TCN4157M025#0070	4	150	25	85	25	85°C	375	20	70	4	29.3	322	67.0
<b>35 Volt @ 85°C</b>													
TCNT475M035#0200	T	4.7	35	85	35	85°C	16.5	10	200	3	1.8	154	18.6
TCNT106M035#0200	T	10	35	85	35	85°C	35	10	200	3	3.9	328	39.5
TCNX476M035#0100	X	47	35	85	28	105°C	165	10	100	3	18.2	387	58.0
TCN3107M035#0150	3	100	35	85	35	85°C	350	20	150	4	38.8	590	88.5
TCN4107M035#0150	4	100	35	85	35	85°C	350	20	150	4	38.8	425	88.5
<b>50 Volt @ 85°C</b>													
TCN4336M050#0200	4	33	50	85	50	85°C	165	20	200	4	26.3	288	59.9

Energy is calculated by this formula (consider derating factor):

$$\text{Energy} = \frac{1}{2} C \times ((V_r \times X)^2 - V_x^2)$$

where C = Capacitance

V<sub>r</sub> = Rated Voltage

X = Recommended derating factor

V<sub>x</sub> = 3V (invariable)

Moisture Sensitivity Level (MSL) is defined according to J-STD-020.

All technical data relates to an ambient temperature of +25°C. Capacitance is measured at 120Hz, 0.5RMS with DC bias of 2.2 volts. DCL is measured at rated voltage after 5 minutes.

ESR allowed to move up to 1.25 times catalog limit post mounting.

For typical weight and composition see page 220.

**NOTE: AVX reserves the right to supply a higher voltage rating in the same case size, to the same reliability standards.**

### RECOMMENDED DERATING

Rated Voltage/ Operating Temp.	≤ 85°C	105°C
≤ 10V	90%	90%
16V	90%	80%
≥ 20V	80%	80%



# J-CAP Series



## Highest Joules/cc Tantalum Solid Electrolytic Chip Capacitors with Conductive Polymer Electrode

### PRODUCT CATEGORY 105°C

TEST	105°C series (Temperature range -55°C to +105°C)										
	Condition			Characteristics							
Endurance	Determine after application of rated voltage for 2000 +48/-0 hours at 85±2°C and then leaving 1-2 hours at room temperature. Also determine after application of 105°C temperature, category voltage for 2000 +48/-0 hours and then leaving 1-2 hours at room temperature. Power supply impedance to be ≤ 0.1Ω/V.			Visual examination	no visible damage						
				DCL	1.25 x initial limit						
				ΔC/C	within +10/-20% of initial value for Ur ≤ 16V within +20/-30% of initial value for Ur ≥ 20V						
				DF	1.5 x initial limit						
				ESR	2 x initial limit						
Storage Life	105°C, 0V, 2000h			Visual examination	no visible damage						
				DCL	1.25 x initial limit						
				ΔC/C	within +10/-20% of initial value for Ur ≤ 16V within +20/-30% of initial value for Ur ≥ 20V						
				DF	1.5 x initial limit						
				ESR	2 x initial limit						
Humidity	Determine after storage without applied voltage at 65±2°C and 95±2% relative humidity for 500 hours and then recovery 1-2 hours at room temperature.			Visual examination	no visible damage						
				DCL	3 x initial limit						
				ΔC/C	within +30/-20% of initial value						
				DF	1.5 x initial limit						
				ESR	2 x initial limit						
Temperature Stability	Step	Temperature°C	Duration(min)								
	1	+20±2	15	+20°C	-55°C	+20°C	+85°C	+105°C	+20°C		
	2	-55+0/-3	15	DCL	IL* n/a IL* 10 x IL* 12.5 x IL* IL*						
	3	+20±2	15	ΔC/C	n/a +0/-20% ±5% +20/-0% +30/-0% ±5%						
	4	+85+3/-0	15	DF	IL* 1.5 x IL* IL* 1.5 x IL* 2 x IL* IL*						
	5	+105+3/-0	15								
	6	+20±2	15								
Surge Voltage	Test temperature: 105°C+3/0°C Test voltage: Category voltage at 105°C Surge voltage: 1.3 x category voltage at 105°C Series protection resistance 1000±100Ω Discharge resistance: 1000Ω Number of cycles: 1000x Cycle duration: 6 min; 30 sec charge, 5 min 30 sec discharge			Visual examination	no visible damage						
				DCL	initial limit						
				ΔC/C	within +10/-20% of initial value for Ur ≤ 16V within +20/-30% of initial value for Ur ≥ 20V						
				DF	1.25 x initial limit						

\*Initial Limit

### PRODUCT CATEGORY 85°C

TEST	85°C series (Temperature range -55°C to +85°C)										
	Condition			Characteristics							
Endurance	Determine after application of rated voltage for 2000 +48/-0 hours at 85±2°C and then leaving 1-2 hours at room temperature. Power supply impedance to be ≤0.1Ω/V.			Visual examination	no visible damage						
				DCL	1.25 x initial limit						
				ΔC/C	within +10/-20% of initial value for Ur ≤ 16V within +20/-30% of initial value for Ur ≥ 20V						
				DF	1.5 x initial limit						
				ESR	2 x initial limit						
Storage Life	85°C, 0V, 2000h			Visual examination	no visible damage						
				DCL	1.25 x initial limit						
				ΔC/C	within +10/-20% of initial value for Ur ≤ 16V within +20/-30% of initial value for Ur ≥ 20V						
				DF	1.5 x initial limit						
				ESR	2 x initial limit						
Humidity	Determine after storage without applied voltage at 65±2°C and 95±2% relative humidity for 500 hours and then recovery 1-2 hours at room temperature.			Visual examination	no visible damage						
				DCL	5 x initial limit						
				ΔC/C	within +40/-20% of initial value						
				DF	1.5 x initial limit						
				ESR	2 x initial limit						
Temperature Stability	Step	Temperature°C	Duration(min)								
	1	+20±2	15	+20°C	-55°C	+20°C	+85°C	+20°C			
	2	-55+0/-3	15	DCL	IL* n/a IL* 10 x IL* IL*						
	3	+20±2	15	ΔC/C	n/a +0/-20% ±5% +20/-0% ±5%						
	4	+85+3/-0	15	DF	IL* 1.5 x IL* IL* 1.5 x IL* IL*						
	5	+20±2	15								
Surge Voltage	Test temperature: 85+3/0°C Test voltage: Rated voltage Surge voltage: 1.3 x rated voltage Series protection resistance 1000±100Ω. Discharge resistance: 1000Ω Number of cycles: 1000x Cycle duration: 6 min; 30 sec charge, 5 min 30 sec discharge			Visual examination	no visible damage						
				DCL	initial limit						
				ΔC/C	within +10/-20% of initial value for Ur ≤ 16V within +20/-30% of initial value for Ur ≥ 20V						
				DF	1.25 x initial limit						

\*Initial Limit

For use outside of recommended conditions and special request, please contact manufacturer.

