

THIS DOCUMENT IS THE PROPERTY OF
KEYSTONE ELECTRONICS CORP. AND
SHALL NOT BE REPRODUCED, DISTRIBUTED
OR USED AS A BASIS FOR MANUFACTURE
WITHOUT PRIOR WRITTEN PERMISSION
FROM KEYSTONE ELECTRONICS CORP.

ACTUAL SIZE

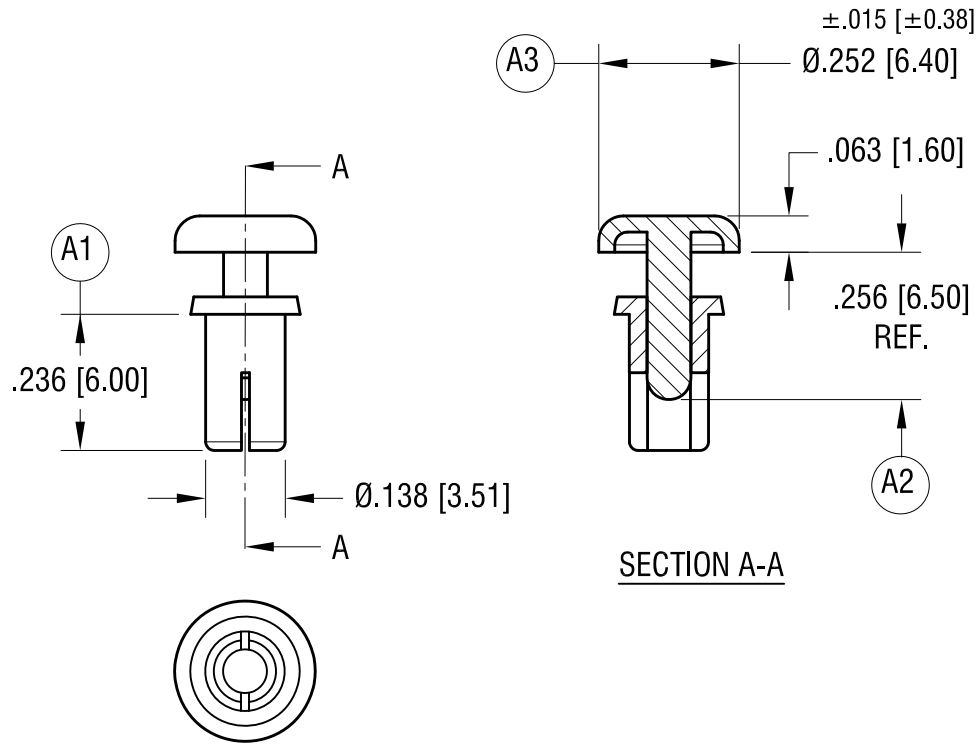

NOTES:

1. RECOMMENDED MOUNTING HOLE:
.144 [3.66] DIA.
2. CHASSIS THICKNESS:
.138 [3.50] TO .177 [4.50]

(A1) WAS .240, (A2) WAS .280
(A3) WAS $.252 \pm .010$

8.27.21 CHANGE AS PER ECN 21-099

KEYSTONE ELECTRONICS CORP.			
www.keyelco.com • NEW HYDE PARK, NY 11040 • Tel (516) 328-7500			
PART NAME		SNAP RIVET	
MATERIAL			
NYLON 6/6 UL 94V-2 (BLACK COLOR)			
FINISH		DRN BY	DATE
NONE		BOONE	9.29.06
		APP'D	SCALE
		RH	3X
TOLERANCES	INCH [MM]	CODE	DWG NO.
DECIMAL	$\pm .010$ [± 0.25]	C	3444
ANGULAR	$\pm 1^\circ$		
UNLESS OTHERWISE SPECIFIED			

DATE	DESCRIPTION	REV.
8.27.21	CHANGE AS PER ECN 21-099	A