

In case of consideration for using Automotive equipment/  
device which demand high reliability, kindly contact our sales window correspondents.

1		2			3			4		
COUNT	DESCRIPTION OF REVISIONS	BY	CHKD	DATE	COUNT	DESCRIPTION OF REVISIONS	BY	CHKD	DATE	
△					△					
△					△					
△					△					

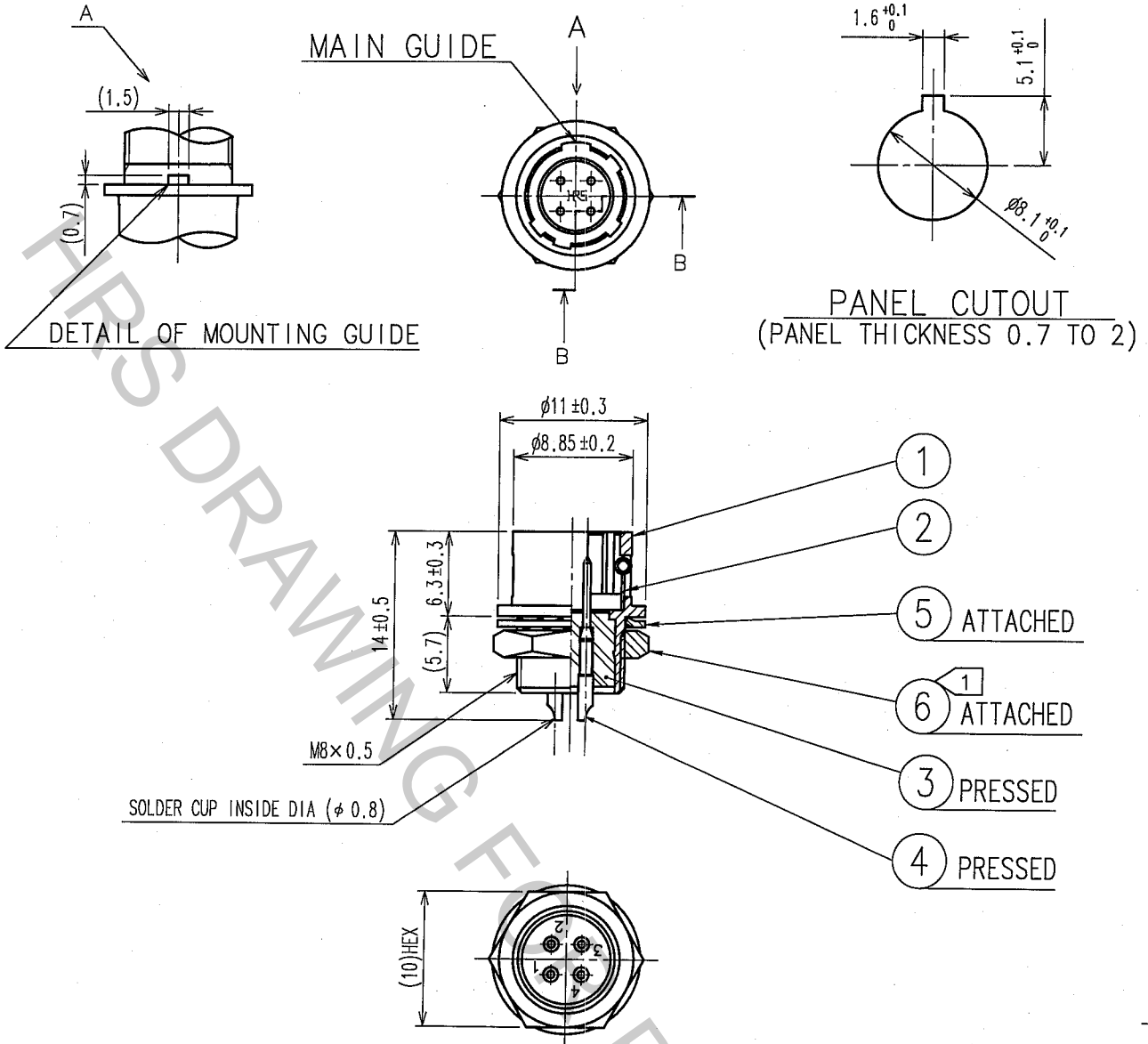

NOTE: ① THE RECOMMENDED CLAMP TORQUE OF REF.NO. ⑥ : 1.5 N · m  
LOCTITE 242, LOCTITE OR EQUIVALENT IS RECOMMENDED TO  
PREVENT REF.NO. ⑥ FROM LOOSENING.

NO.	MATERIAL	FINISH, REMARKS	NO.	MATERIAL	FINISH, REMARKS
3	POLYAMIDE	(BLACK) UL94V-0	6	BRASS	NICKEL PLATING
2	STAINLESS STEEL		5	PHOSPHOR BRONZE	NICKEL PLATING
1	ZINC ALLOY	MATTE FINISH NICKEL PLATED	4	BRASS	SILVER PLATING 2μ m min

CODE NO. (OLD) CL	DRAWN T. HORII 05.12.9	DESIGNED T. Magomo 05.12.09	CHECKED E. Kurita 05.12.09	APPROVED M. Sato 05.12.10	RELEASED
----------------------	------------------------------	-----------------------------------	----------------------------------	---------------------------------	----------

SACLE 2 : 1	DRAWING NO. EDC4-020539-73	PART NO. HR10A-7R-4P(73)
	UNITS mm	CODE NO. CL110-0306-6-73

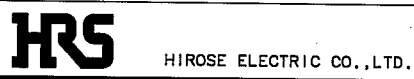
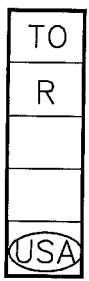

1/1