

# 5 Port Solenoid Valve

Reduced power consumption:

**0.55 W** [With power saving circuit]  
**1.55 W** [Standard]  
 (Conventional: 2.0 W) Note) With DC light



Series VF3000

## Power consumption is reduced by power saving circuit.

Power consumption is decreased by approx. 1/3 by reducing the wattage required to hold the valve in an energized state. (Effective energizing time is over 40 ms at 24 VDC.) Refer to electrical power waveform as shown below.

Electrical power waveform with power saving circuit

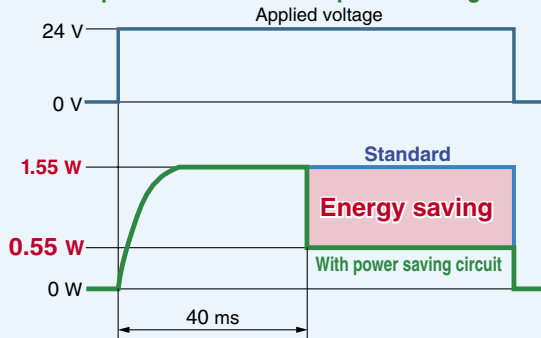

## ■ Built-in full-wave rectifier (AC)

### ● Noise reduction

Noise is considerably reduced by changing it to DC mode with a full-wave rectifier.

### ● Reduced apparent power

Conventional: 5.6 VA → **1.55 VA**

## ■ Built-in strainer in the pilot valve

Unexpected troubles due to foreign matter can be prevented.

Note) Be sure to mount an air filter on the inlet side.

**Rubber material: HNBR**  
**Ozone-resistant specification**  
(The pilot valve poppet is made of FKM.)

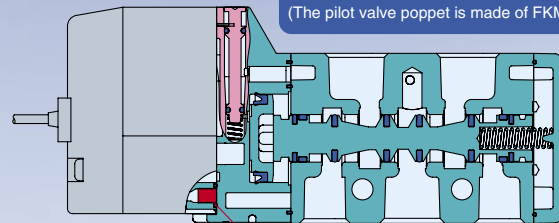

Strainer

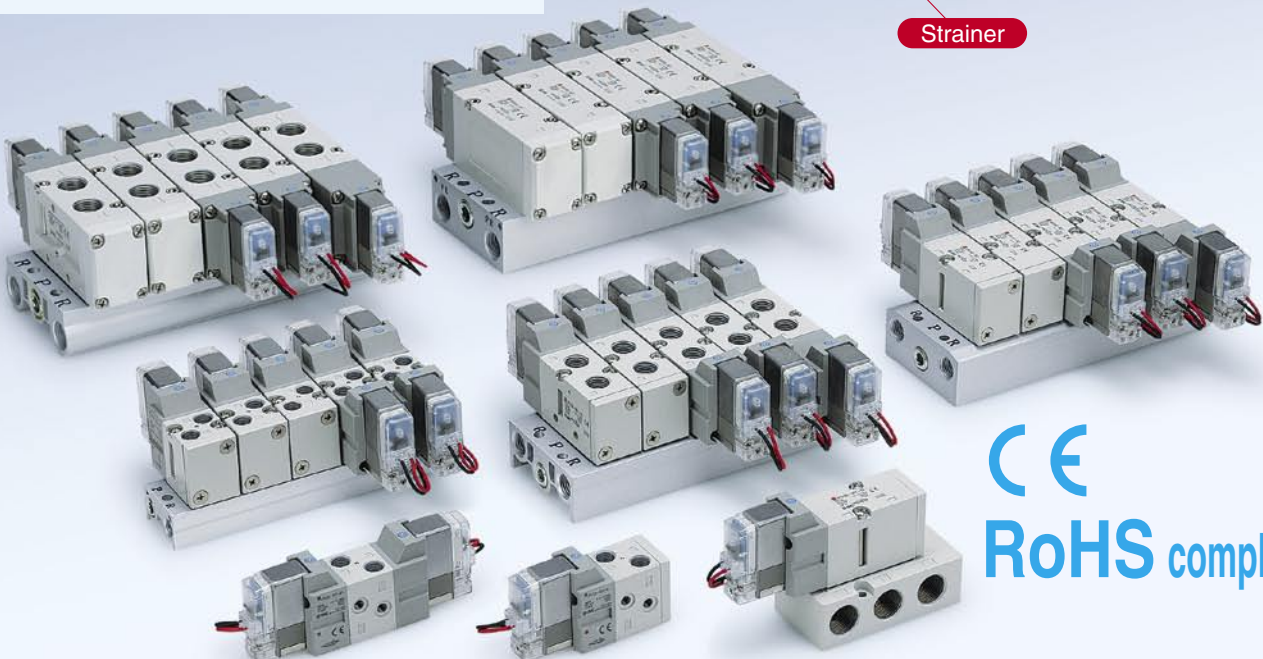

CE  
**RoHS compliant**









Series **VF1000/3000/5000**

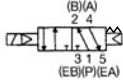
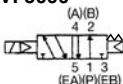
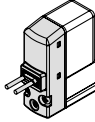

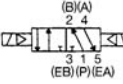
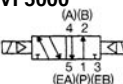
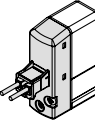
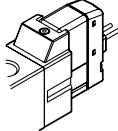
CAT.EUS11-99A-UK

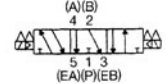
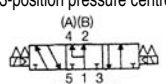
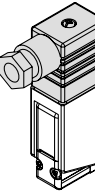
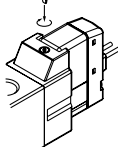
## Model Selection by Operating Conditions 1

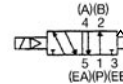
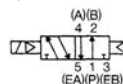
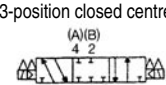
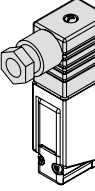
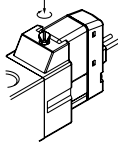
### Single Unit

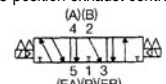
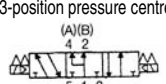
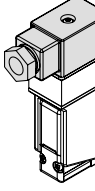

Series	Sonic conductance C [dm <sup>3</sup> /(s·bar)]	Type of actuation	Port size	Voltage	Electrical entry	Light/surge voltage suppressor	Manual override		
Body ported	<b>VF1000</b> 	2-position single <b>VF1000</b>  <b>VF3000</b> <b>VF5000</b> 	M5 x 0.8 1/8		Grommet 				
	<b>VF3000</b> 	2-position double <b>VF1000</b>  <b>VF3000</b> <b>VF5000</b> 			1/8 1/4			L-type plug connector 	Non-locking push type 
	<b>VF5000</b> 	3-position closed centre  3-position exhaust centre  3-position pressure centre 			1/4 3/8			DIN terminal 	Push-turn locking slotted type 
Base mounted	<b>VF3000</b> 	2-position single  2-position double  3-position closed centre 	1/4 3/8		DIN (EN1753 01-803) terminal 	DC ■ With surge voltage suppressor ■ With light/surge voltage suppressor ■ With surge voltage suppressor (Non-polar) ■ With light/surge voltage suppressor (Non-polar) AC ■ With light/surge voltage suppressor	Push-turn locking lever type 		
	<b>VF5000</b> 	3-position exhaust centre  3-position pressure centre 			1/4 3/8 1/2			Conduit terminal 	

P. 1

P. 15

# Model Selection by Operating Conditions 2

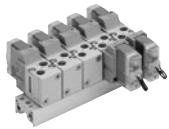
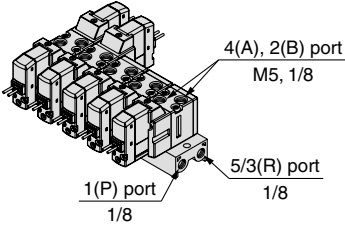
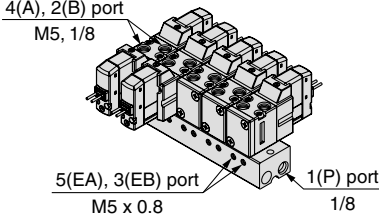
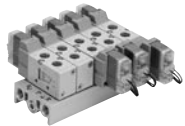
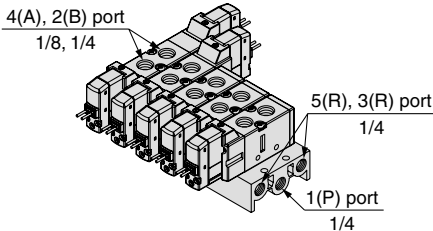
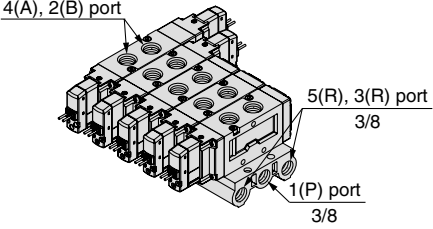
## Manifold

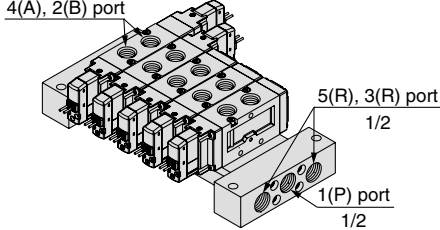
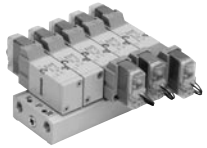
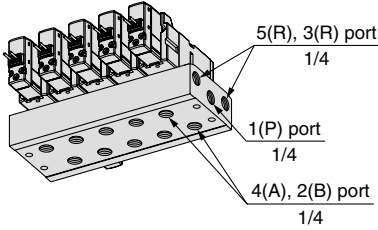
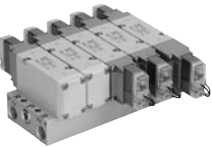
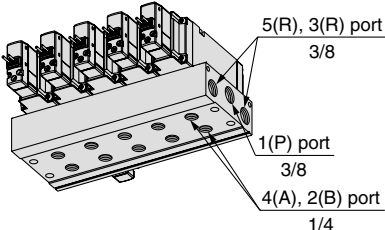
Series	EXH port type	Manifold base model	Applicable valve	Applicable stations	
<b>VF1000</b>  	Common EXH	<b>VV5F1-30</b>  <p>4(A), 2(B) port M5, 1/8 1(P) port 1/8 5/3(R) port 1/8</p>	VF1□30 VF1□33	2 to 20 stations	
	Individual EXH	<b>VV5F1-31</b>  <p>4(A), 2(B) port M5, 1/8 5(EA), 3(EB) port M5 x 0.8 1(P) port 1/8</p>			
	<b>VF3000</b>  	Common EXH	<b>VV5F3-30</b>  <p>4(A), 2(B) port 1/8, 1/4 5(R), 3(R) port 1/4 1(P) port 1/4</p>	VF3□30 VF3□33	2 to 20 stations
		Common EXH	<b>VV5F5-20</b>  <p>4(A), 2(B) port 5(R), 3(R) port 3/8 1(P) port 3/8</p>	VF5□20 VF5□23	2 to 10 stations
<b>VF5000</b>  	Common EXH	<b>VV5F5-21</b>  <p>4(A), 2(B) port 5(R), 3(R) port 1/2 1(P) port 1/2</p>	2 to 15 stations		
	<b>VF3000</b>  	Common EXH	<b>VV5F3-40</b>  <p>5(R), 3(R) port 1/4 1(P) port 1/4 4(A), 2(B) port 1/4</p>	VF3□40 VF3□43	2 to 20 stations
<b>VF5000</b>  		Common EXH	<b>VV5F5-40</b>  <p>5(R), 3(R) port 3/8 1(P) port 3/8 4(A), 2(B) port 1/4</p>	VF5□44	2 to 10 stations

P. 27

P. 39

# Cylinder Speed Chart 1

This chart is provided as guidelines only.  
For performance under various conditions, use SMC's  
Model Selection Program before making a judgement.

## Body Ported

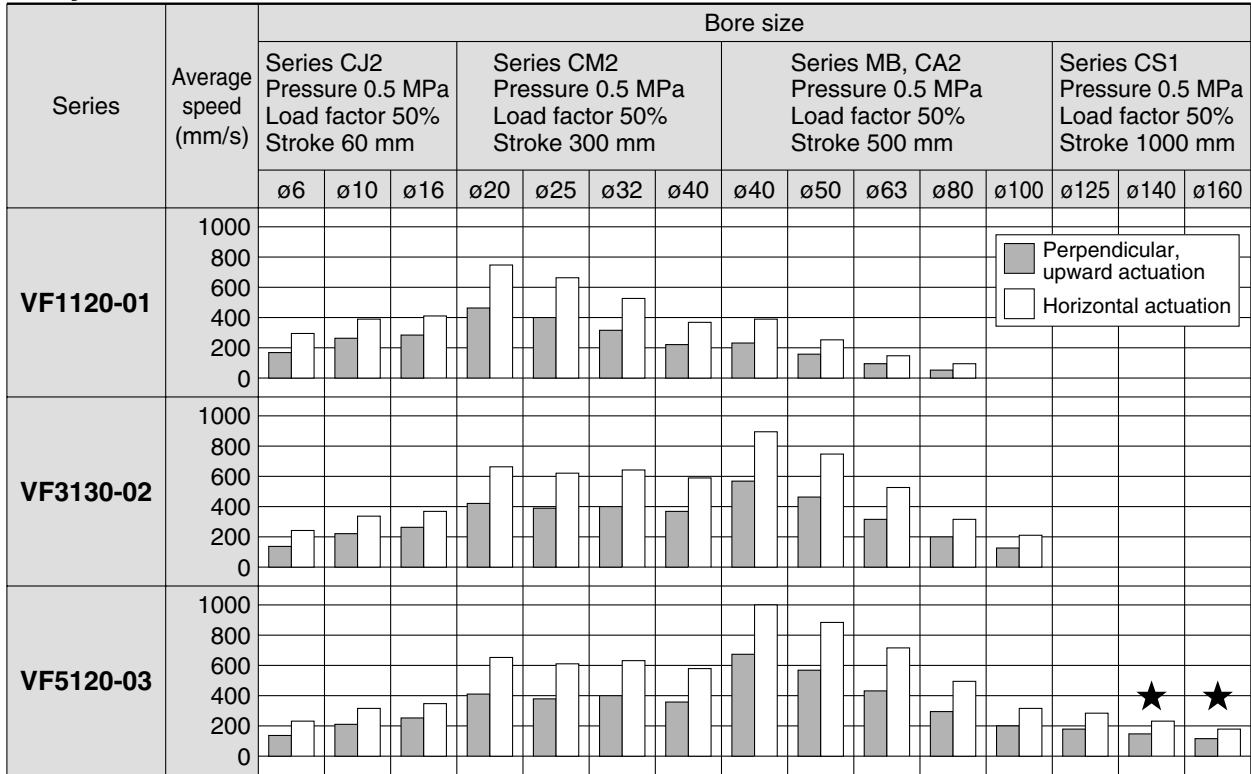

Note) With ★: when using steel piping

## Base Mounted

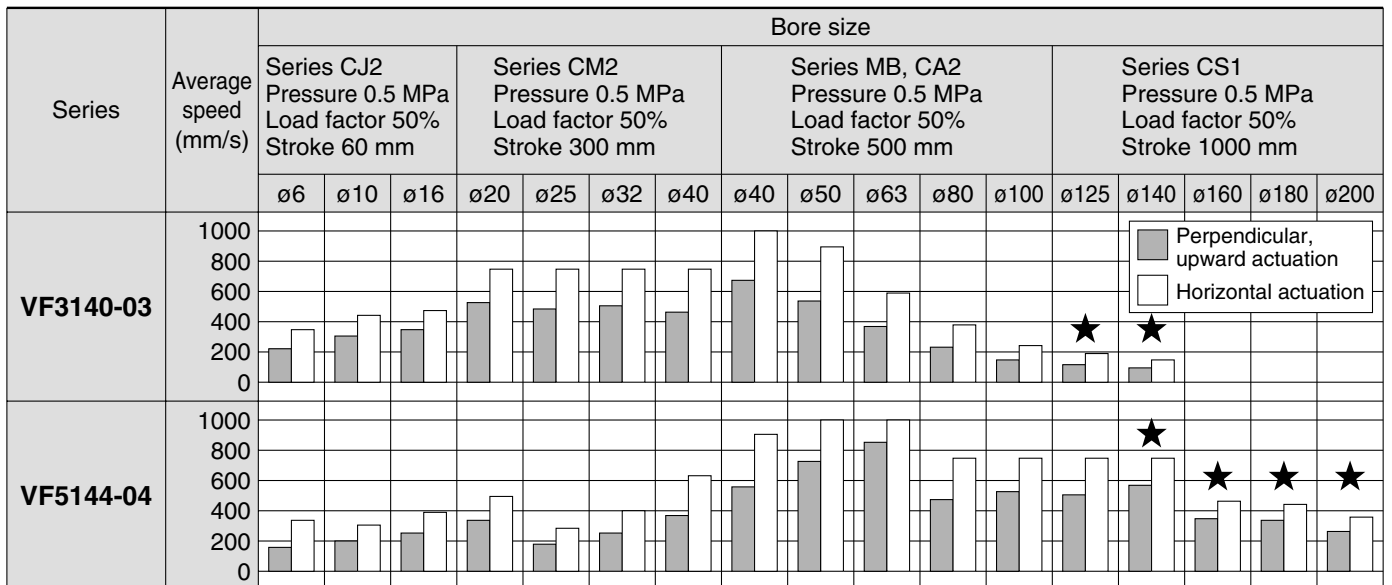

Note) With ★: when using steel piping



# Cylinder Speed Chart 2

This chart is provided as guidelines only.  
For performance under various conditions, use SMC's  
Model Selection Program before making a judgement.

## Conditions

### Body Ported

Body ported		Series CJ2	Series CM2	Series MB, CA2	Series CS1
VF1120-01	Tube bore x Length	T0604 x 1 m	T0806 x 1 m		—
	Speed controller	AS3001F-06	AS3001F-08		—
	Silencer	AN101-01			—
VF3130-02	Tube bore x Length	T0604 x 1 m	T1075 x 1 m		—
	Speed controller	AS3001F-06	AS4001F-10		—
	Silencer	AN110-01			—
VF5120-03	Tube bore x Length	T0604 x 1 m	T1075 x 1 m	T1209 x 1 m	
	Speed controller	AS3001F-06	AS4001F-10	AS4001F-12	
	Silencer	AN200-02			AN202-02

### Body Ported [when using SGP (Steel Piping)]

Body ported		Series CS1
VF5120-03	Tube bore x Length	SGP10A x 1 m
	Speed controller	AS420-03
	Silencer	AN200-02

### Base Mounted

Base mounted		Series CJ2	Series CM2	Series MB, CA2	Series CS1
VF3140-03	Tube bore x Length	T0604 x 1 m	T1075 x 1 m	T1209 x 1 m	—
	Speed controller	AS3001F-06	AS4001F-10	AS4001F-12	—
	Silencer	AN200-02			—
VF5144-04	Tube bore x Length	T0604 x 1 m	T1075 x 1 m	T1209 x 1 m	
	Speed controller	AS3001F-06	AS4001F-10	AS4001F-12	
	Silencer	AN200-02			

### Base Mounted [when using SGP (Steel Piping)]

Base mounted		Series CS1
VF3140-03	Tube bore x Length	SGP10A x 1 m
	Speed controller	AS420-03
	Silencer	AN300-03
VF5144-04	Tube bore x Length	SGP15A x 1 m
	Speed controller	AS420-04
	Silencer	AN400-04

# Pilot Operated 5 Port Solenoid Valve

## Series VF1000/3000/5000

### Single Unit

Body Ported

#### How to Order Valve



Note) Only DIN and conduit terminal types are available with AC mode. Refer to the electrical entry for details.

Body ported **VF 3 1 3 0** - **5 G** - **1-01** - - -

**Series**

1	VF1000
3	VF3000
5	VF5000

**Type of actuation**

1	2-position single
2	2-position double
3	3-position closed centre
4	3-position exhaust centre
5	3-position pressure centre

Note) Only 1 and 2 are available with the VF1000.

**Body model**

Symbol	VF1000	VF3000	VF5000
2	○	—	○
3	—	○	—

**Pressure specification**

—	Standard (0.7 MPa)
K	High-pressure type (1 MPa)

**Body option**

**0: Pilot valve individual exhaust**

VF1000	VF3000	VF5000
○	○	○

**3: Main/Pilot valve common exhaust**

VF1000	VF3000	VF5000
—	○	○

Note) Refer to "Made to Order" (P.14) when piping to PE port is required.

**Coil specification**

—	Standard
T	With power saving circuit (DC only)

Note 1) Be sure to select the power saving circuit type when it is continuously energized for long periods of time. (Refer to back pages 6 and 7 for details.)

Note 2) T type is available with DC mode only. When T is selected, only Z type of light/surge voltage suppressor is available. (Note that when the electrical entry of DIN terminal type without connector is selected, only DOS and YOS options are available.)

**Rated voltage**

DC		AC (50/60 Hz)			
5	24 VDC	1	100 VAC	2	200 VAC
6	12 VDC	3	110 VAC [115 VAC]	4	220 VAC [230 VAC]
		7	240 VAC	8	24 VAC

Note) Only DIN and conduit terminal types can be set for AC mode. Refer to electrical entry for details.

**Thread type**

—	Rc
F	G
N	NPT
T	NPTF

Note) M5 is available with Nil only.

**Bracket**

—	Without bracket
F	With bracket

VF1000/3000 Single type (The bracket cannot be connected after delivered.)

VF1000 Double type only

Note) Not available with the VF5000.

**Made to Order**

—	—
X500	Pilot exhaust port with piping thread (M3) specification (Refer to page 14).

**A, B port size**

Symbol	Port size	VF1000	VF3000	VF5000
M5	M5 x 0.8	○	—	—
01	1/8	○	○	—
02	1/4	—	○	○
03	3/8	—	—	○

**Electrical entry**

	Grommet	L-type plug connector	M-type plug connector	DIN terminal	DIN (EN175301-803) terminal	Conduit terminal
<b>G:</b> Lead wire length 300 mm						
<b>H:</b> Lead wire length 600 mm				<b>D:</b> With connector	<b>Y:</b> With connector	<b>T:</b> Conduit terminal
<b>G:</b> Lead wire length 300 mm		<b>LN:</b> Without lead wire	<b>MN:</b> Without lead wire			
<b>H:</b> Lead wire length 600 mm				<b>DO:</b> Without connector	<b>YO:</b> Without connector	
Without light/surge voltage suppressor		<b>LO:</b> Without connector	<b>MO:</b> Without connector			
DC	○	○	○	○	○	○
AC	—	—	—	○	○	○

Note 1) LN and MN types are with 2 sockets.  
 Note 2) Refer to back page 4 when different length of lead wire for L/M-type plug connector is required.  
 Note 3) Refer to back page 5 for details on the DIN (EN175301-803) terminal.  
 Note 4) When using with IP65, select the main/pilot valve common exhaust type. (Except VF1000)

**Manual override**

—: Non-locking push type	<b>D:</b> Push-turn locking slotted type	<b>E:</b> Push-turn locking lever type

**Light/surge voltage suppressor**

Symbol	Light/surge voltage suppressor	DC	AC
—	Without light/surge voltage suppressor	○	○
S	With surge voltage suppressor	○	— <sup>Note 1)</sup>
Z	With light/surge voltage suppressor	○	○
R	With surge voltage suppressor (Non-polar)	○	—
U	With light/surge voltage suppressor (Non-polar)	○	—

Note 1) There is no S option for AC mode, since a rectifier prevents surge voltage generation.  
 Note 2) In the DIN terminal type, since a light is installed in the connector, DOZ, DOU, YOZ, YOU options are not available.

**Caution**  
 When using the surge voltage suppressor type, residual voltage will remain. Refer to back page 7 for details.



# Pilot Operated 5 Port Solenoid Valve *Series VF1000/3000/5000*

Body Ported/Single Unit

## Specifications



Model		VF1000	VF3000	VF5000
<b>Fluid</b>		Air		
<b>Operating pressure range (MPa)</b>	Standard	2-position single/3-position	0.15 to 0.7	
		2-position double	0.1 to 0.7	
	High-pressure type	2-position single/3-position	0.15 to 1.0	
		2-position double	0.1 to 1.0	
<b>Ambient and fluid temperature (°C)</b>		-10 to 50 (No freezing)		
<b>Max. operating frequency (Hz)</b>	2-position single/double	10	10	5
	3-position	—	3	3
<b>Manual override</b>		Non-locking push type Push-turn locking slotted type Push-turn locking lever type		
<b>Pilot exhaust type</b>		Individual exhaust, Main/Pilot valve common exhaust (Except VF1000)		
<b>Lubrication</b>		Not required		
<b>Mounting orientation</b>		Unrestricted		
<b>Impact/Vibration resistance (m/s<sup>2</sup>)</b> <small>Note 1)</small>		300/50		
<b>Enclosure</b>		Dustproof (IP65 <small>Note 2)</small> for D, Y, T)		

Note 1) Impact resistance: No malfunction occurred when it is tested in the axial direction and at the right angles to the main valve and armature in both energized and de-energized states every once for each condition. (Values at the initial period)

Vibration resistance: No malfunction occurred in a one-sweep test between 45 and 2000 Hz. Test was performed at both energized and de-energized states in the axial direction and at the right angles to the main valve and armature. (Values at the initial period)

Note 2) Based on IEC60529. When using with IP65, select the main/pilot valve common exhaust type.



**Made to Order**  
(Refer to page 14 for details.)

<b>X500</b>	Pilot exhaust port with piping thread (M3) specification
-------------	--

## Solenoid Specifications

<b>Electrical entry</b>		Grommet (G), (H)	DIN terminal (D)
		L-type plug connector (L)	DIN (EN175301-803) terminal (Y)
		M-type plug connector (M)	Conduit terminal (T)
		G, H, L, M	D, Y, T
<b>Coil rated voltage (V)</b>	<b>DC</b>	24, 12	
	<b>AC (50/60 Hz)</b>	—	24, 100, 110, 200, 220, 240
<b>Allowable voltage fluctuation</b>		±10% <small>Note 1,2,3)</small> of rated voltage	
<b>Power consumption (W)</b>	<b>DC</b>	<b>Standard</b>	1.5 (With light: 1.55)
		With power saving circuit	0.55 (With light only)
<b>Apparent power (VA)</b> <small>Note 1,2,3)</small>	<b>AC</b>	100 V	1.5 (With light: 1.75)
		110 V [115 V]	1.55 (With light: 1.7)
		200 V	
		220 V [230 V]	
		240 V	
<b>Surge voltage suppressor</b>		Diode (Non-polar type: Varistor)	
<b>Indicator light</b>		LED (Neon bulb is used for AC mode)	

Note 1) It is in common between 110 VAC and 115 VAC, and between 220 VAC and 230 VAC.

Note 2) Allowable voltage fluctuation is -15% to +5% of the rated voltage for 115 VAC or 230 VAC.

Note 3) Since voltage drops due to the internal circuit in S, Z, T types (with power saving circuit), the allowable voltage fluctuation should be within the following range.

24 VDC: -7% to +10%

12 VDC: -4% to +10%

## Response Time

Series	Type of actuation		Pressure specification	Operating pressure range (MPa)	Response time ms (at 0.5 MPa)			
					Without light/surge voltage suppressor	With light/surge voltage suppressor		AC
						S, Z type	R, U type	
VF1000	2-position	Single	Standard	0.15 to 0.7	20	45	23	45
		Double		0.1 to 0.7	12	12	12	
	2-position	Single	High-pressure type	0.15 to 1.0	23	48	26	48
		Double		0.1 to 1.0	15	15	15	
VF3000	2-position	Single	Standard	0.15 to 0.7	20	45	23	45
		Double		0.1 to 0.7	12	12	12	
	3-position		High-pressure type	0.15 to 0.7	30	55	33	55
	2-position	Single		0.15 to 1.0	23	48	26	
		Double	0.1 to 1.0	15	15	15		
	3-position		High-pressure type	0.15 to 1.0	33	58	36	58
VF5000	2-position	Single		Standard	0.15 to 0.7	30	55	
		Double	0.1 to 0.7		15	15	15	
	3-position		High-pressure type	0.15 to 0.7	50	75	53	75
	2-position	Single		0.15 to 1.0	33	58	36	
Double		0.1 to 1.0	18	18	18			
3-position		High-pressure type	0.15 to 1.0	53	78	56	78	

Note) Based on dynamic performance test, JIS B 8375-1981. (Coil temperature: 20°C, at rated voltage)

# Series VF1000/3000/5000

## Flow-rate Characteristics/Weight

Valve model	Type of actuation		Port size		Flow-rate characteristics <small>Note 1)</small>								Weight (g) <small>Note 2)</small>	
			1, 4, 2 (P, A, B)	5, 3 (EA, EB)	1 → 4/2 (P → A/B)				4/2 → 5/3 (A/B → EA/EB)					
					C [dm <sup>3</sup> / (s/bar)]	b	Cv	Q [l/min] (ANR) <small>Note 3)</small>	C [dm <sup>3</sup> / (s/bar)]	b	Cv	Q [l/min] (ANR) <small>Note 3)</small>	Grommet	DIN terminal
VF1□20-M5	2- position	Single	M5 x 0.8		0.49	0.40	0.13	133	0.52	0.35	0.13	137	140	176
		Double			0.49	0.40	0.13	133	0.52	0.35	0.13	137	200	272
VF1□20-01	2- position	Single	1/8	M5 x 0.8	0.76	0.22	0.17	184	0.53	0.28	0.13	133	136	172
		Double			0.76	0.22	0.17	185	0.53	0.28	0.13	133	196	268
VF3□30-01	2- position	Single	1/8		3.0	0.38	0.78	805	2.8	0.30	0.67	712	182	218
		Double			3.0	0.38	0.78	805	2.8	0.30	0.67	712	243	315
	3- position	Closed centre			2.4	0.31	0.64	614	1.8	0.37	0.46	479	260	332
		Exhaust centre			2.6	0.37	0.70	692	3.0	0.32	0.76	773	260	332
		Pressure centre			3.0	0.42	0.83	828	2.4	0.27	0.59	599	260	332
VF3□30-02	2- position	Single	1/4	1/8	4.0	0.36	1.0	1058	3.1	0.32	0.75	798	178	214
		Double			4.0	0.36	1.0	1058	3.1	0.32	0.75	798	239	311
	3- position	Closed centre			2.4	0.45	0.68	678	1.9	0.37	0.47	506	256	328
		Exhaust centre			3.0	0.42	0.82	828	3.1	0.36	0.79	820	256	328
		Pressure centre			5.5	0.37	1.4	1465	2.6	0.32	0.64	670	256	328
VF5□20-02	2- position	Single	1/4		7.1	0.46	1.9	2021	7.7	0.51	2.2	2282	313	349
		Double			7.1	0.46	1.9	2021	7.7	0.51	2.2	2282	368	440
	3- position	Closed centre			6.7	0.46	1.8	1907	6.6	0.41	1.8	188	406	478
		Exhaust centre			7.1	0.42	1.9	1960	8.0	0.45	2.2	2259	406	478
		Pressure centre			6.8	0.51	2.0	2016	5.7	0.37	1.4	1518	406	478
VF5□20-03	2- position	Single	3/8		8.8	0.44	2.4	2466	10.0	0.49	2.9	2915	299	335
		Double			8.8	0.44	2.4	2466	10.0	0.49	2.9	2915	354	426
	3- position	Closed centre			7.5	0.43	2.0	2086	7.5	0.38	1.9	2011	391	463
		Exhaust centre			8.3	0.40	2.2	2258	10.0	0.48	3.0	2892	391	463
		Pressure centre			9.2	0.50	2.6	2704	6.1	0.35	1.6	1603	391	463

Note 1) [ ]: Normal position

Note 2) Values without bracket

Note 3) These valves have been calculated according to ISO6358 and indicate the flow rate under standard conditions with an inlet pressure of 0.6 MPa (relative pressure) and a pressure drop of 0.1 MPa.

# Pilot Operated 5 Port Solenoid Valve Body Ported/Single Unit *Series VF1000/3000/5000*

## Construction/Body Ported

### 2-position single

Symbol

**2-position single**

**VF1000**

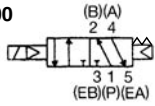

**VF3000**

**VF5000**

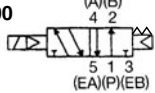

**VF1000**

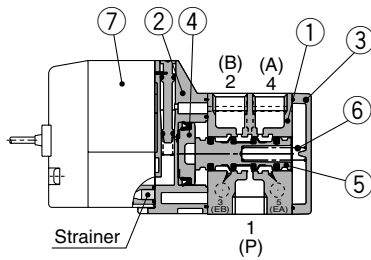

**VF3000/5000**

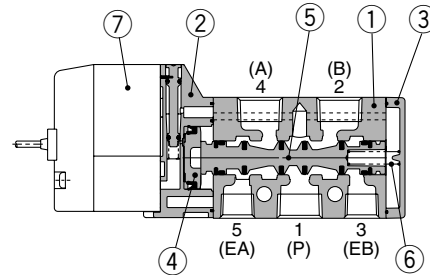

### 2-position double

Symbol

**2-position double**

**VF1000**

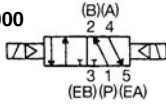

**VF3000**

**VF5000**

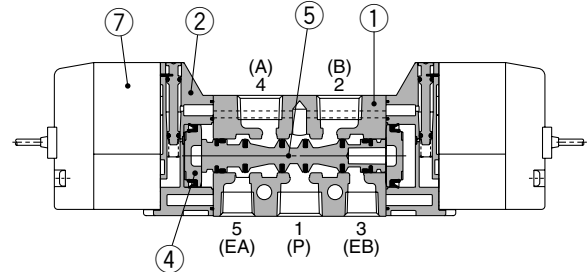
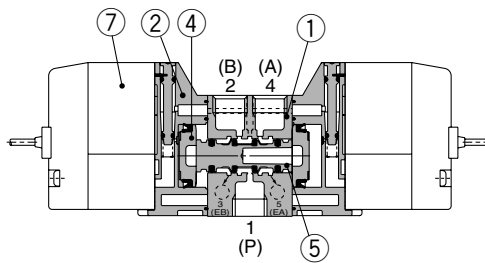
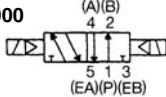

### 3-position closed centre/exhaust centre/pressure centre

Symbol

**3-position closed centre**

**VF1000**



**3-position exhaust centre**

**VF1000**

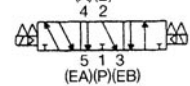

**3-position pressure centre**

**VF1000**

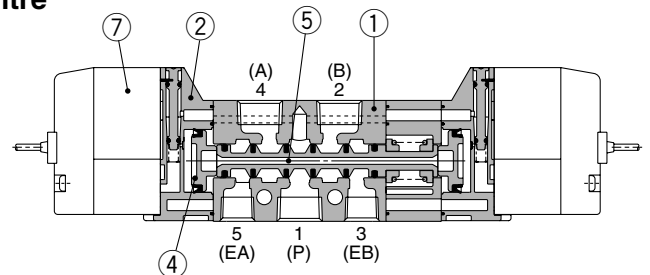

(Drawing shows a closed centre type.)

### Component Parts

No.	Description	Material	Note
1	<b>Body</b>	Aluminum die-casted	White
2	<b>Adapter plate</b>	Resin	Grey
3	<b>End plate</b>	Aluminum die-casted (VF5000: Resin)	White
4	<b>Piston</b>	Resin	
5	<b>Spool valve</b>	Aluminum, HNBR	
6	<b>Spring</b>	Stainless steel	

### Replacement Parts

No.	Description	Part no.	Note
7	<b>Pilot valve assembly</b>	Refer to "How to Order Pilot Valve Assembly" on page 5.	Built-in strainer

### Bracket Assembly Part No.

Description	Part no.
<b>Bracket (for VF1000/3000 single)</b> <small>Note)</small>	VF3000-64-1A (With 2 mounting screws)
<b>Bracket (for VF1000 double)</b>	DXT144-8-1A (With 2 mounting screws)

Note) The bracket cannot be mounted after delivered.



# Series VF1000/3000/5000

## How to Order Pilot Valve Assembly

### ⚠ Caution

When only the pilot valve assembly is replaced, it is not possible to change from V211 (Grommet or L/M-type) to V212 (DIN or Conduit type), or vice versa.

Valve model: VF       - 5 G Z  1 -

Note) Select from the below in accordance with the valve used.

### ■ Grommet or L/M-type

V 2 1 1   - 5 G Z

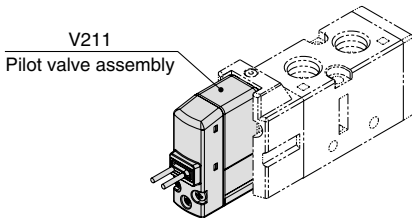

#### ● Light/surge voltage suppressor

—	Without light/surge voltage suppressor
S	With surge voltage suppressor
Z	With light/surge voltage suppressor
R	With surge voltage suppressor (Non-polar)
U	With light/surge voltage suppressor (Non-polar)

Note) When T is selected, only Z type of light/surge voltage suppressor is available.

### ⚠ Caution

When using the surge voltage suppressor type, residual voltage will remain. Refer to back page 7 for details.

#### ● Electrical entry

G	Grommet (Lead wire length 300 mm)	
H	Grommet (Lead wire length 600 mm)	
L	L-type plug connector	With lead wire
LN		Without lead wire
LO	M-type plug connector	Without connector
M		With lead wire
MN		Without lead wire
MO		Without connector

Note 1) LN and MN types are with 2 sockets.

Note 2) Refer to back page 4 when different length of lead wire for L/M-type plug connector is required.

### ■ DIN or Conduit type

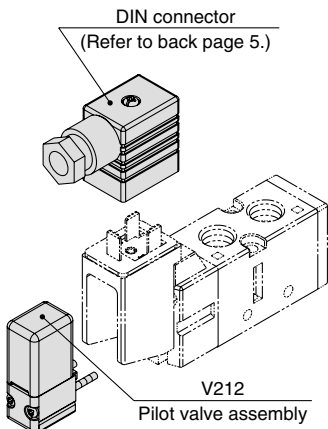

V 2 1 2   - 5

#### ● Pressure specification

—	Standard (0.7 MPa)
K	High-pressure type (1 MPa)

#### ● Coil specification

—	Standard
T	With power saving circuit (DC only)

Note) T type is available with DC mode only.

#### ● Rated voltage

##### DC

5	24 VDC
6	12 VDC

##### AC (50/60 Hz)

1	100 VAC
2	200 VAC
3	110 VAC [115 VAC]
4	220 VAC [230 VAC]
7	240 VAC
8	24 VAC

Note) Only V212 type can be set for AC mode. V211 type can not be set for AC mode.

### ⚠ Caution

For V212 (DIN or Conduit type), the coil specification and voltage (including light/surge voltage suppressor) cannot be changed by changing the pilot valve assembly.

### ⚠ Caution

Tightening torque of the pilot valve assembly mounting screw  
M2.5: 0.32 N·m

# Pilot Operated 5 Port Solenoid Valve Series VF1000/3000/5000

## Series VF1000/Body Ported/Dimensions

### 2-position single

#### Grommet (G) (H): VF1120-□<sup>G</sup>□□-M5□ (-F)

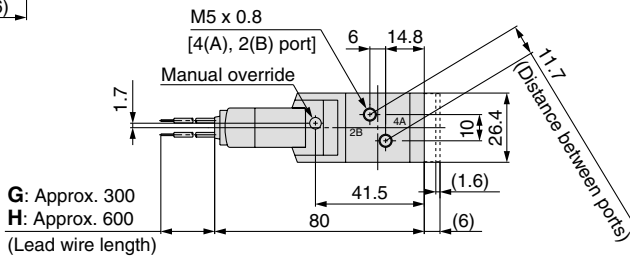
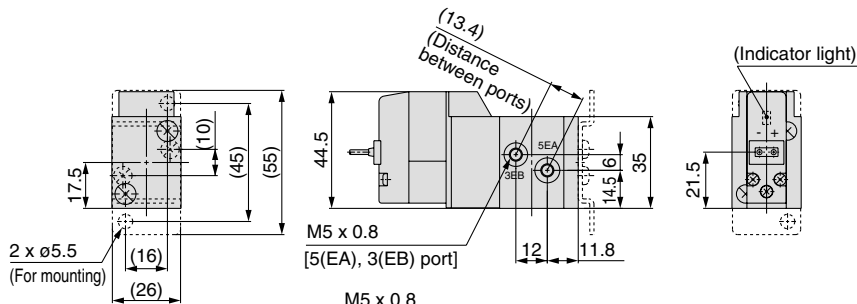
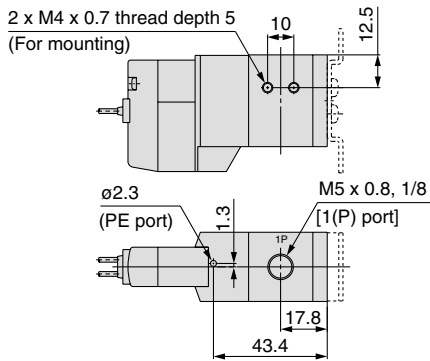

#### Grommet (G) (H): VF1120-□<sup>G</sup>□□-01□ (-F)

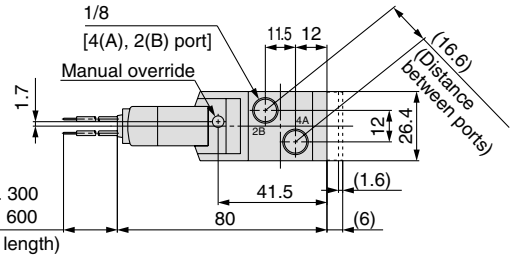

#### Grommet (G) (H) DC without light/surge voltage suppressor

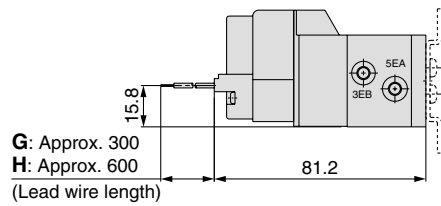

#### L-type plug connector (L): VF1120-□L□□-M5<sub>01</sub>□ (-F)

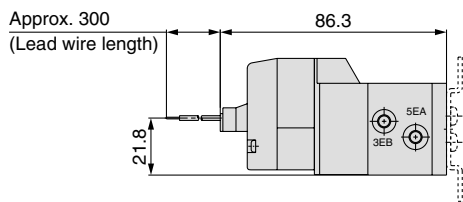

Unless otherwise indicated, dimensions are the same as Grommet (G).

#### DIN terminal (D) (Y): VF1120-□<sup>D</sup>□□-M5<sub>01</sub>□ (-F)

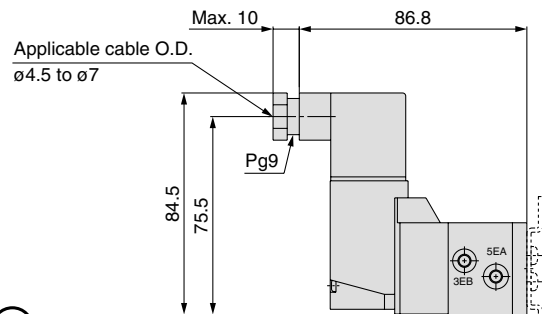

Unless otherwise indicated, dimensions are the same as Grommet (G).

#### M-type plug connector (M): VF1120-□M□□-M5<sub>01</sub>□ (-F)

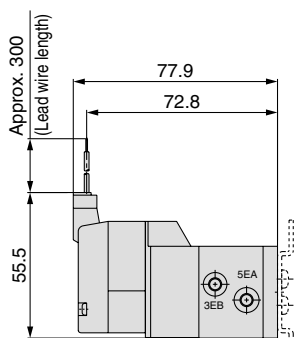

Unless otherwise indicated, dimensions are the same as Grommet (G).

#### Conduit terminal (T): VF1120-□T□□-M5<sub>01</sub>□ (-F)

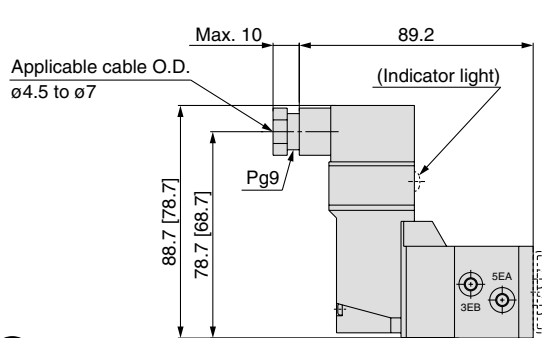

[ ]: Without indicator light  
Unless otherwise indicated, dimensions are the same as Grommet (G).

# Series VF1000/3000/5000

## Series VF1000/Body Ported/Dimensions

### 2-position double

Grommet (G) (H): VF1220-□<sup>G</sup>□□-M5□

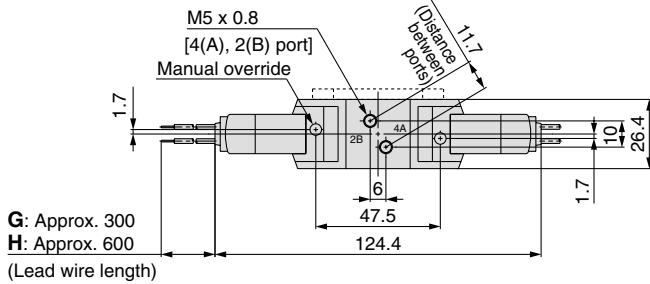
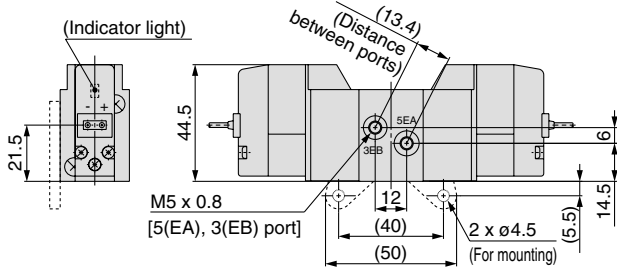
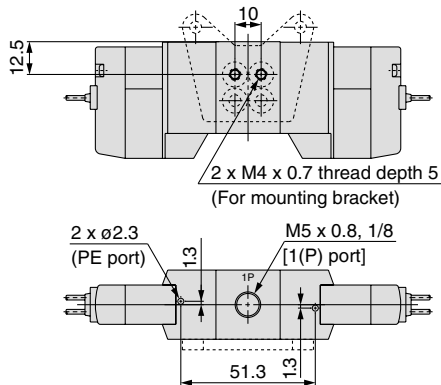

Grommet (G) (H): VF1220-□<sup>G</sup>□□-01□

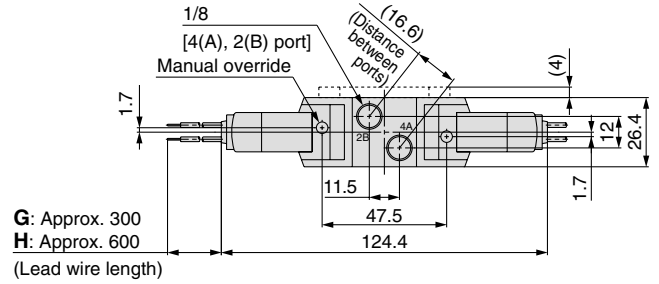

Grommet (G) (H)  
DC without light/surge voltage suppressor

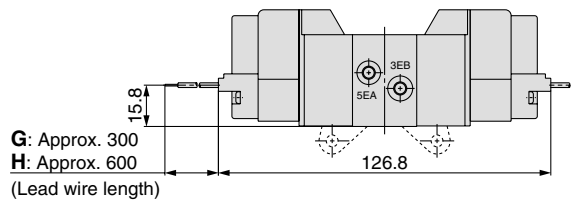

L-type plug connector (L): VF1220-□<sup>L</sup>□□-M5<sub>01</sub>□

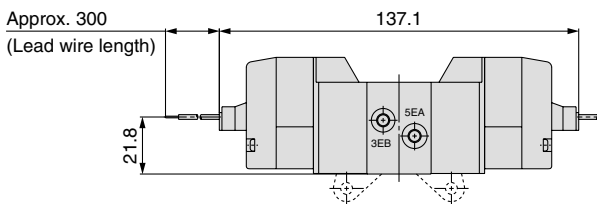

Unless otherwise indicated, dimensions are the same as Grommet (G).

DIN terminal (D) (Y): VF1220-□<sup>D</sup>□□-M5<sub>01</sub>□

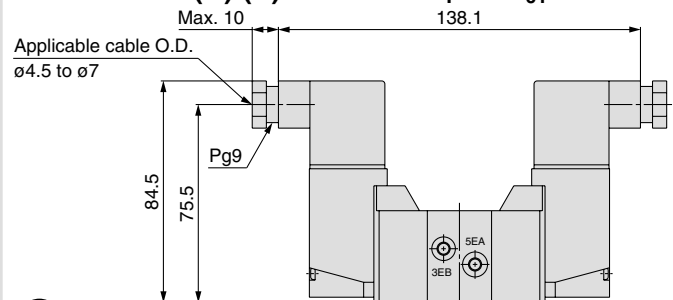

Unless otherwise indicated, dimensions are the same as Grommet (G).

M-type plug connector (M): VF1220-□<sup>M</sup>□□-M5<sub>01</sub>□

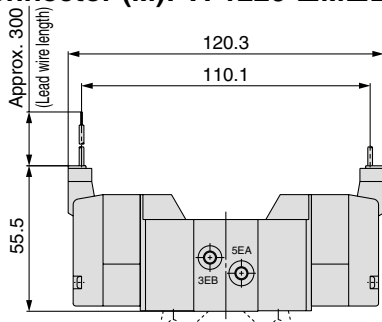

Unless otherwise indicated, dimensions are the same as Grommet (G).

Conduit terminal (T): VF1220-□<sup>T</sup>□□-M5<sub>01</sub>□

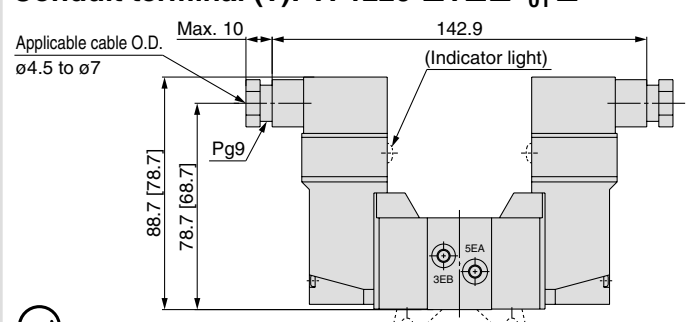

[ ]: Without indicator light  
Unless otherwise indicated, dimensions are the same as Grommet (G).

Pilot Operated 5 Port Solenoid Valve  
 Body Ported/Single Unit **Series VF1000/3000/5000**

**Series VF3000/Body Ported/Dimensions**

**2-position single**

**Grommet (G) (H): VF3130-□<sup>G</sup>□□-01□ (-F)**

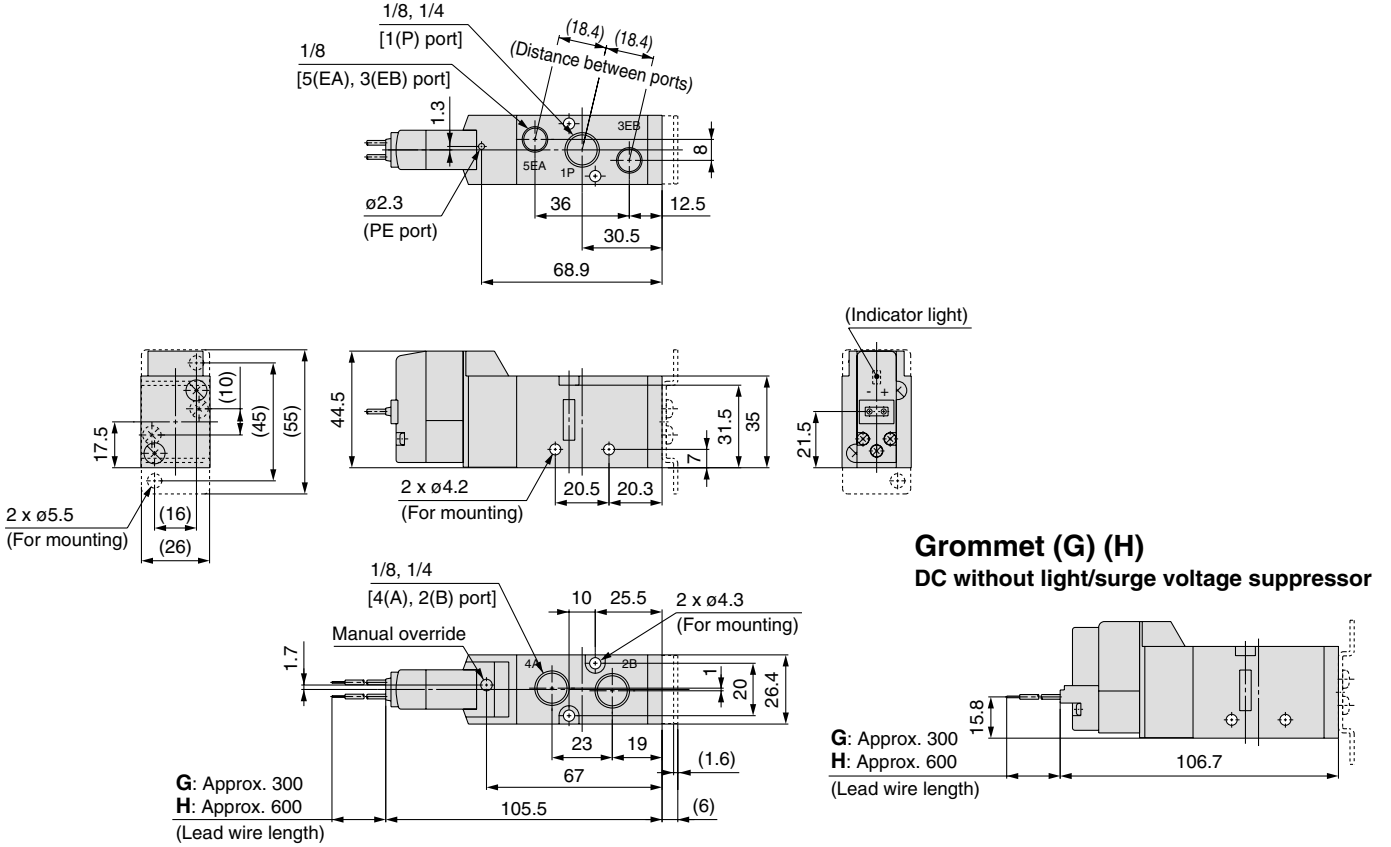

**L-type plug connector (L): VF3130-□L□□-01□ (-F)**

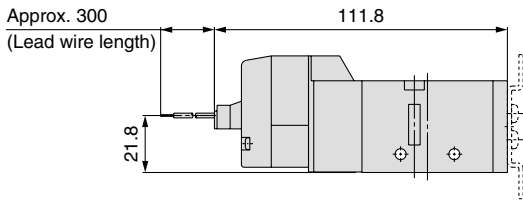

Unless otherwise indicated, dimensions are the same as Grommet (G).

**DIN terminal (D) (Y): VF3130-□<sup>D</sup>□□-01□ (-F)**

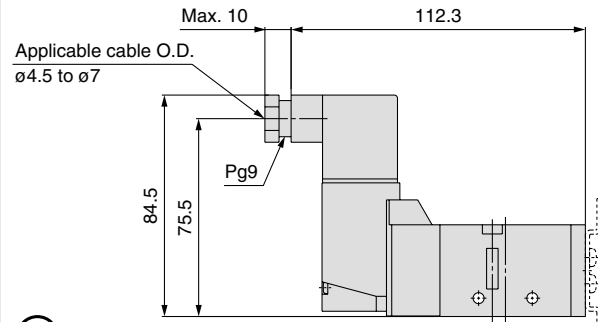

Unless otherwise indicated, dimensions are the same as Grommet (G).

**M-type plug connector (M): VF3130-□M□□-01□ (-F)**

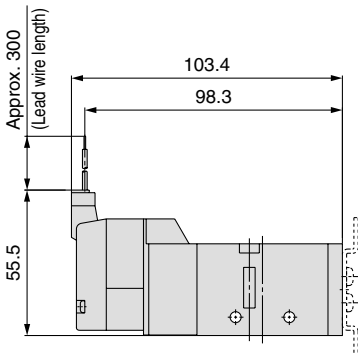

Unless otherwise indicated, dimensions are the same as Grommet (G).

**Conduit terminal (T): VF3130-□T□□-01□ (-F)**

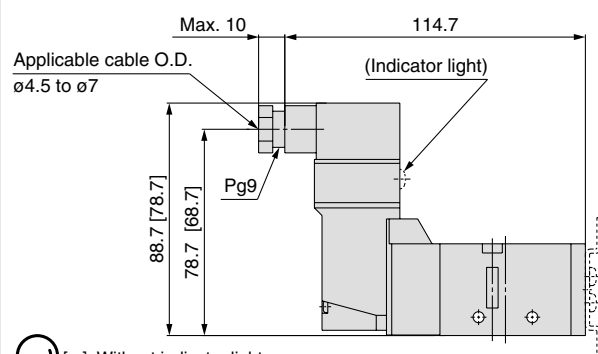

[ ] : Without indicator light  
 Unless otherwise indicated, dimensions are the same as Grommet (G).

# Series VF1000/3000/5000

## Series VF3000/Body Ported/Dimensions

### 2-position double

Grommet (G) (H): VF3230-□<sup>G</sup><sub>H</sub>□□-01□

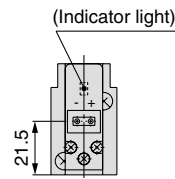
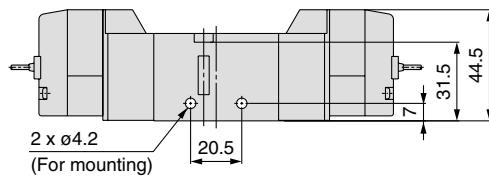
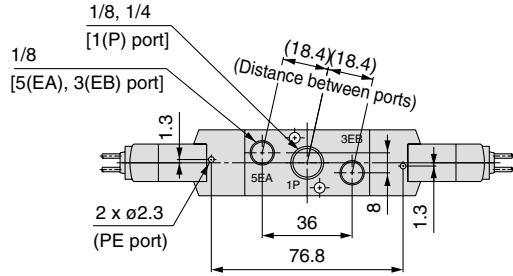

### Grommet (G) (H)

DC without light/surge voltage suppressor

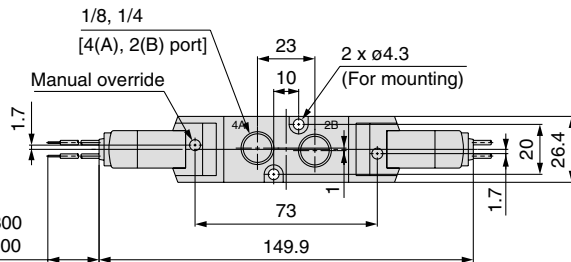

G: Approx. 300  
H: Approx. 600  
(Lead wire length)

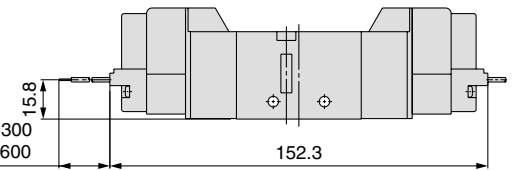

G: Approx. 300  
H: Approx. 600  
(Lead wire length)

### L-type plug connector (L): VF3230-□L□□-01□

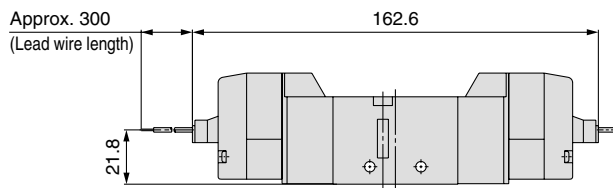

Unless otherwise indicated, dimensions are the same as Grommet (G).

### DIN terminal (D) (Y): VF3230-□<sup>D</sup><sub>Y</sub>□□-01□

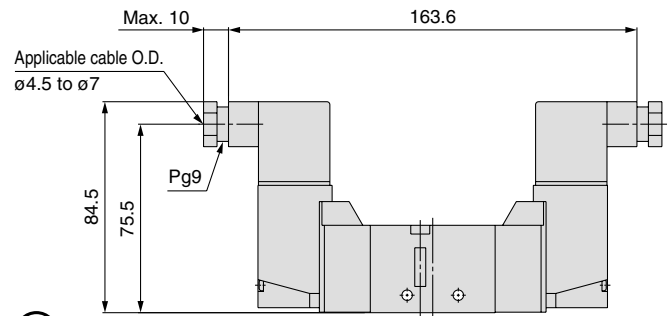

Unless otherwise indicated, dimensions are the same as Grommet (G).

### M-type plug connector (M): VF3230-□M□□-01□

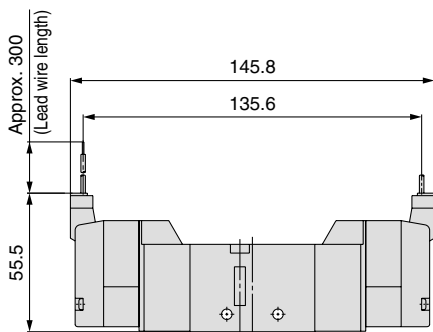

Unless otherwise indicated, dimensions are the same as Grommet (G).

### Conduit terminal (T): VF3230-□T□□-01□

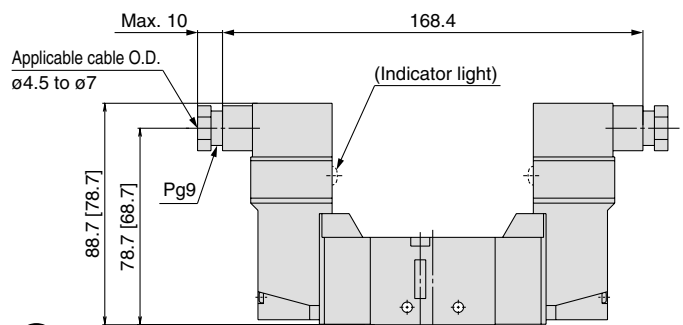

[ ]: Without indicator light  
Unless otherwise indicated, dimensions are the same as Grommet (G).



Pilot Operated 5 Port Solenoid Valve  
 Body Ported/Single Unit **Series VF1000/3000/5000**

**Series VF3000/Body Ported/Dimensions**

3-position closed centre/exhaust centre/pressure centre

Grommet (G) (H): VF3<sup>3</sup><sub>5</sub>430-□<sup>G</sup>□□-<sup>01</sup>□□

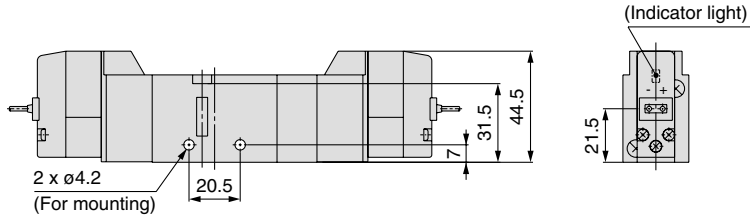
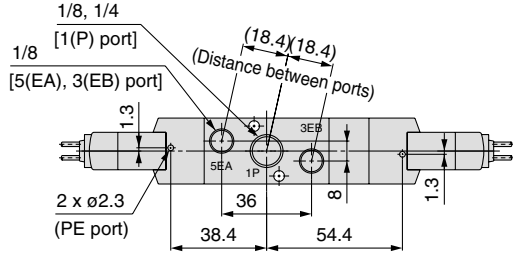

**Grommet (G) (H)**  
 DC without light/surge voltage suppressor

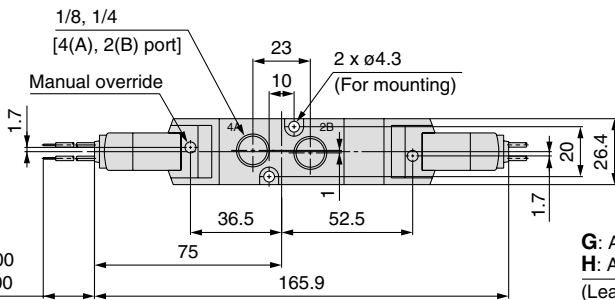

G: Approx. 300  
 H: Approx. 600  
 (Lead wire length)

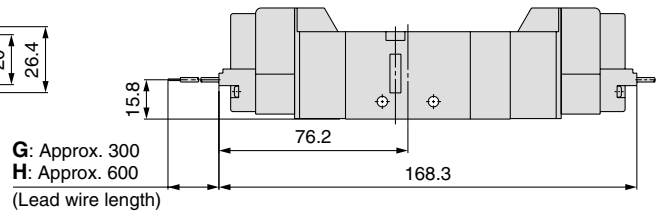

G: Approx. 300  
 H: Approx. 600  
 (Lead wire length)

L-type plug connector (L): VF3<sup>3</sup><sub>5</sub>430-□L□□-<sup>01</sup>□□

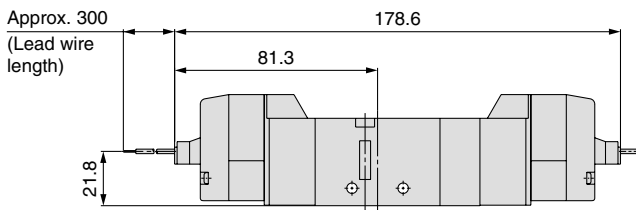

Approx. 300  
 (Lead wire length)

Unless otherwise indicated, dimensions are the same as Grommet (G).

DIN terminal (D) (Y): VF3<sup>3</sup><sub>5</sub>430-□<sup>D</sup>□□-<sup>01</sup>□□

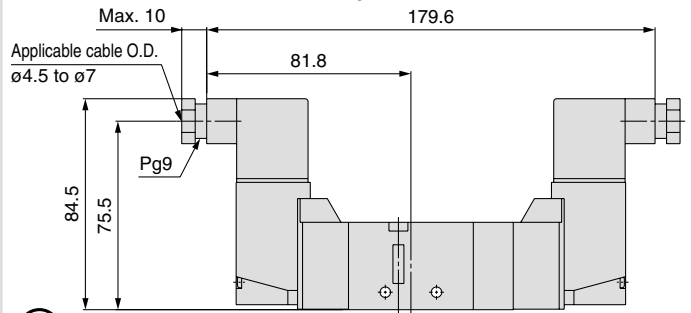

Unless otherwise indicated, dimensions are the same as Grommet (G).

M-type plug connector (M): VF3<sup>3</sup><sub>5</sub>430-□M□□-<sup>01</sup>□□

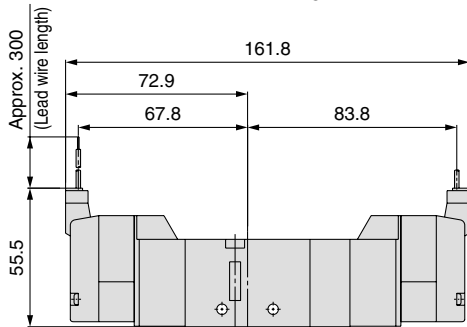

Approx. 300  
 (Lead wire length)

Unless otherwise indicated, dimensions are the same as Grommet (G).

Conduit terminal (T): VF3<sup>3</sup><sub>5</sub>430-□T□□-<sup>01</sup>□□

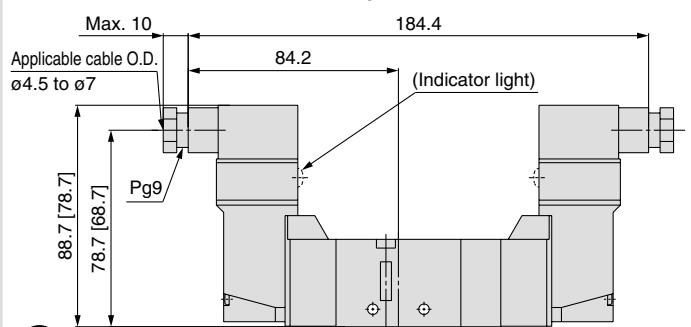

[ ] : Without indicator light  
 Unless otherwise indicated, dimensions are the same as Grommet (G).

# Series VF1000/3000/5000

## Series VF5000/Body Ported/Dimensions

### 2-position single

Grommet (G) (H): VF5120-□<sup>G</sup><sub>H</sub>□□-02□

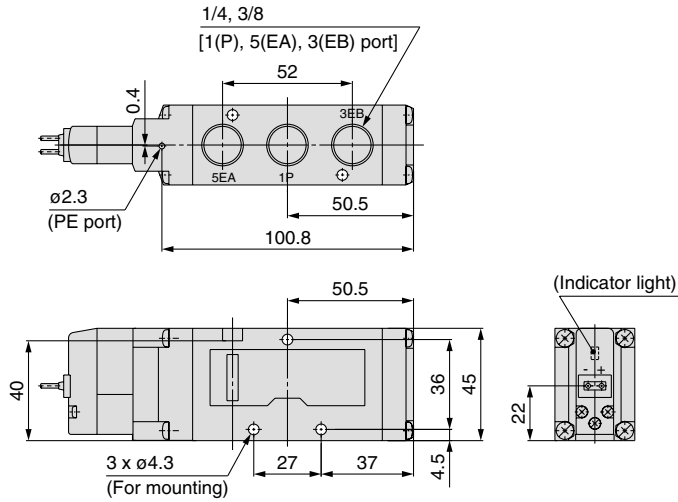

G: Approx. 300  
H: Approx. 600  
(Lead wire length)

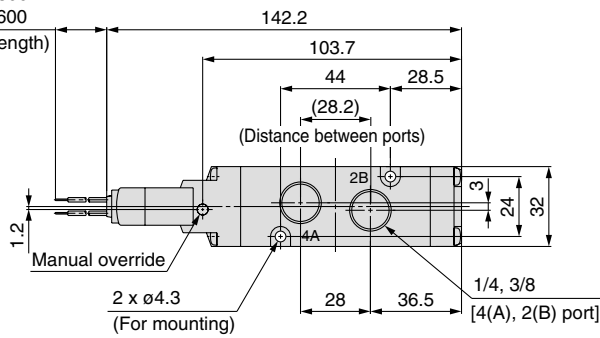

### Grommet (G) (H)

DC without light/surge voltage suppressor

G: Approx. 300  
H: Approx. 600  
(Lead wire length)

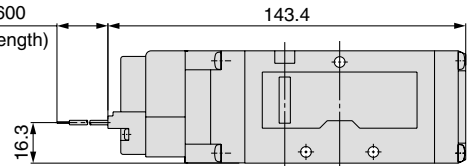

### L-type plug connector (L): VF5120-□L□□-02□

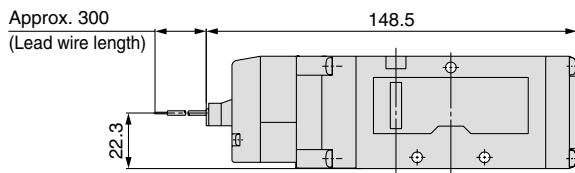

Unless otherwise indicated, dimensions are the same as Grommet (G).

### DIN terminal (D) (Y): VF5120-□<sup>D</sup><sub>Y</sub>□□-02□

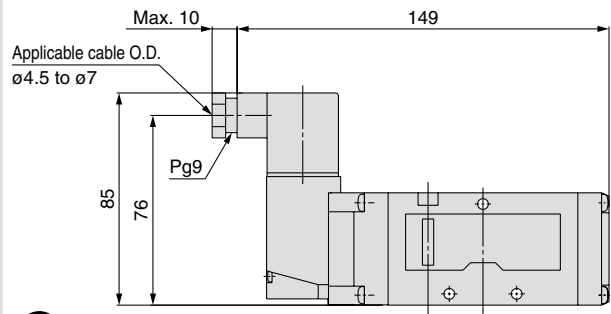

Unless otherwise indicated, dimensions are the same as Grommet (G).

### M-type plug connector (M): VF5120-□M□□-02□

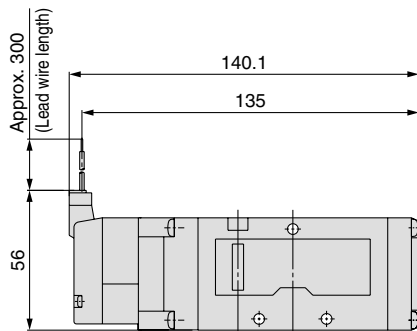

Unless otherwise indicated, dimensions are the same as Grommet (G).

### Conduit terminal (T): VF5120-□T□□-02□

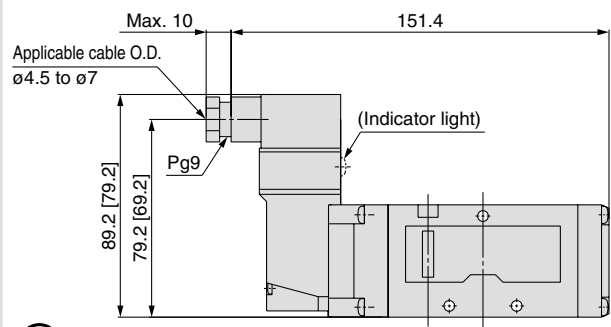

[ ]: Without indicator light  
Unless otherwise indicated, dimensions are the same as Grommet (G).

Pilot Operated 5 Port Solenoid Valve  
 Body Ported/Single Unit **Series VF1000/3000/5000**

**Series VF5000/Body Ported/Dimensions**

**2-position double**

**Grommet (G) (H):** VF5220-□<sup>G</sup><sub>H</sub>□□-02□□

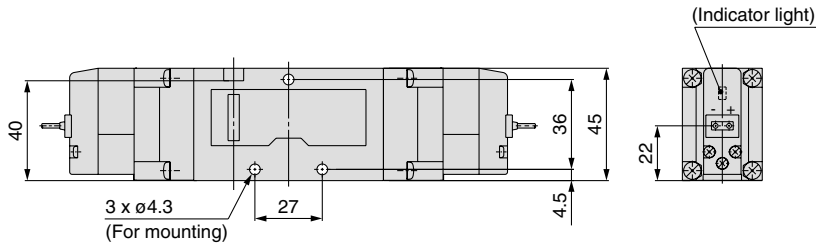
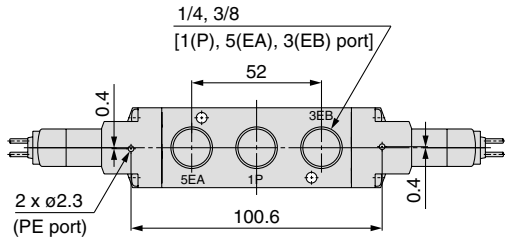

G: Approx. 300  
 H: Approx. 600  
 (Lead wire length)

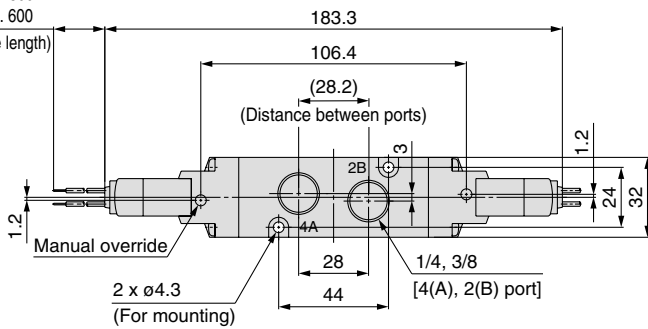

**Grommet (G) (H)**

**DC without light/surge voltage suppressor**

G: Approx. 300  
 H: Approx. 600  
 (Lead wire length)

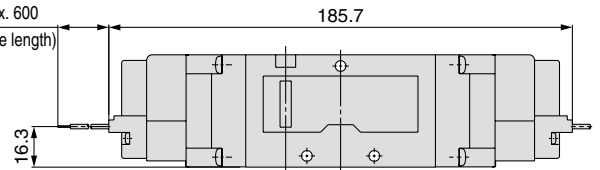

**L-type plug connector (L):** VF5220-□L□□-02□□

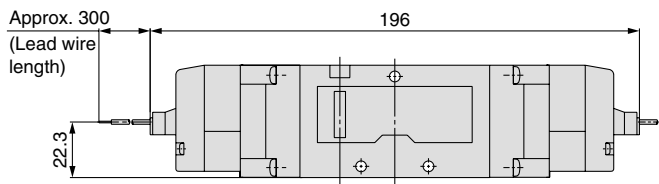

Unless otherwise indicated, dimensions are the same as Grommet (G).

**DIN terminal (D) (Y):** VF5220-□<sup>D</sup><sub>Y</sub>□□-02□□

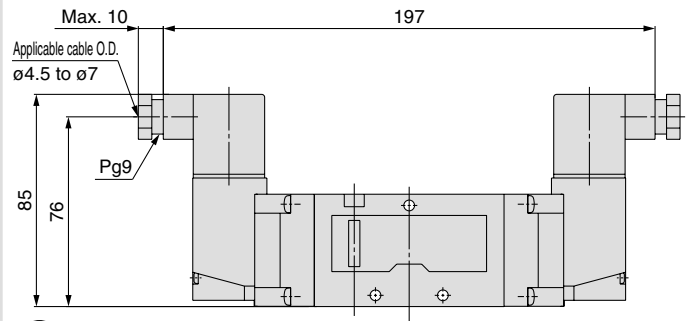

Unless otherwise indicated, dimensions are the same as Grommet (G).

**M-type plug connector (M):** VF5220-□M□□-02□□

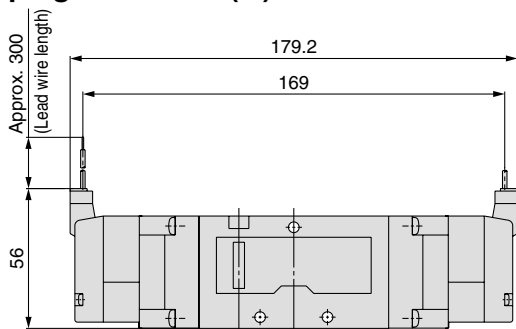

Unless otherwise indicated, dimensions are the same as Grommet (G).

**Conduit terminal (T):** VF5220-□T□□-02□□

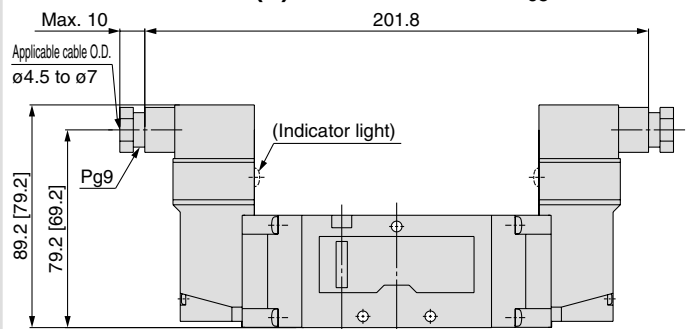

[ ]: Without indicator light  
 Unless otherwise indicated, dimensions are the same as Grommet (G).

# Series VF1000/3000/5000

## Series VF5000/Body Ported/Dimensions

3-position closed centre/exhaust centre/pressure centre

Grommet (G) (H): VF5<sup>3</sup><sub>4</sub>20-□<sup>G</sup>□□-<sup>02</sup><sub>03</sub>□

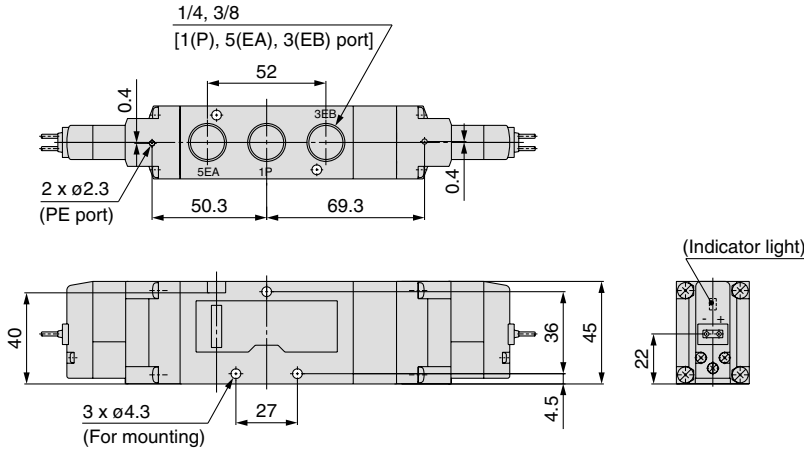

G: Approx. 300  
H: Approx. 600

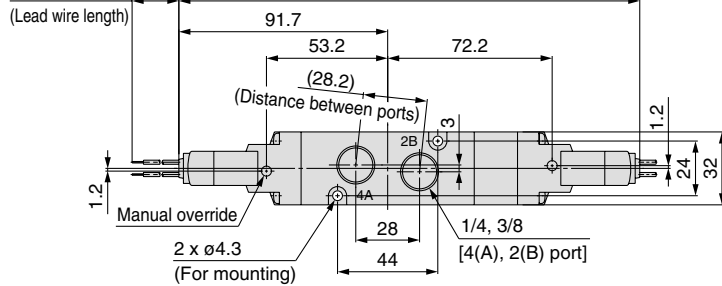

Grommet (G) (H)  
DC without light/surge voltage suppressor

G: Approx. 300  
H: Approx. 600  
(Lead wire length)

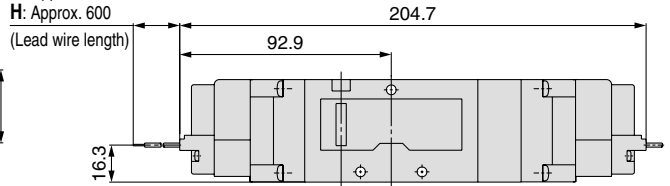

L-type plug connector (L): VF5<sup>3</sup><sub>4</sub>20-□L□□-<sup>02</sup><sub>03</sub>□

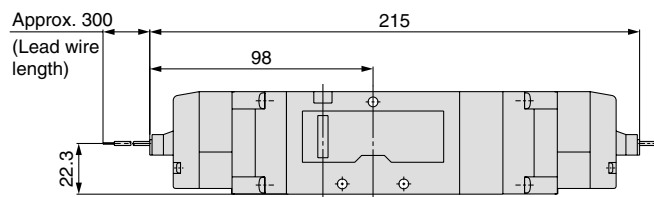

DIN terminal (D) (Y): VF5<sup>3</sup><sub>4</sub>20-□<sup>D</sup>□□-<sup>02</sup><sub>03</sub>□

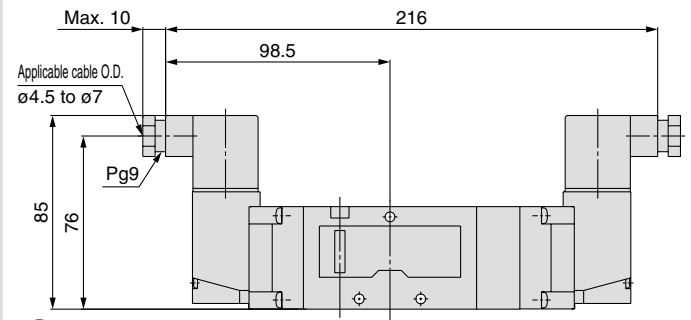

Unless otherwise indicated, dimensions are the same as Grommet (G).

Unless otherwise indicated, dimensions are the same as Grommet (G).

M-type plug connector (M): VF5<sup>3</sup><sub>4</sub>20-□M□□-<sup>02</sup><sub>03</sub>□

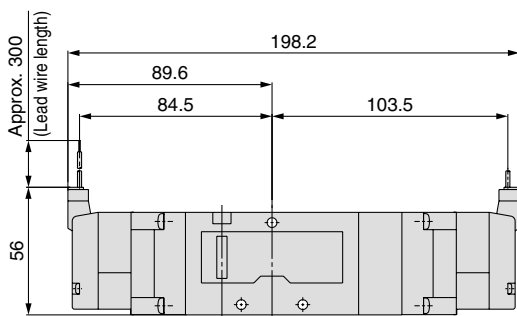

Conduit terminal (T): VF5<sup>3</sup><sub>4</sub>20-□T□□-<sup>02</sup><sub>03</sub>□

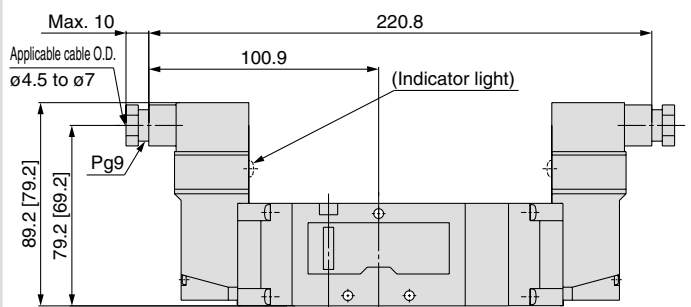

Unless otherwise indicated, dimensions are the same as Grommet (G).

[ ] : Without indicator light  
Unless otherwise indicated, dimensions are the same as Grommet (G).

# Series VF1000/3000/5000

# Made to Order



Please contact SMC for detailed dimensions, specifications, and lead times.

## 1 Body Ported Pilot Exhaust Port with Piping Thread (M3) Specification

In this specification, piping to the pilot exhaust port (PE port) is available when the valve is used in an environment where the exhaust from the pilot valve is not allowable, or intrusion of ambient dust should be prevented.

### How to Order Valve

**VF 3**    **3 0**       -             **1** -          -    - **X500**

**Series**

1	VF1000
3	VF3000
5	VF5000

**Type of actuation**

1	2-position single
2	2-position double
3	3-position closed centre
4	3-position exhaust centre
5	3-position pressure centre

**Body model**

Symbol	VF1000	VF3000	VF5000
2	○	—	○
3	—	○	—

• Entry is the same as standard products.  
The specifications and performance are the same as those of standard models.

#### • 2-position single

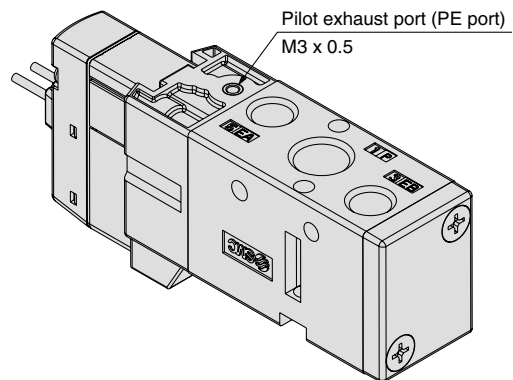
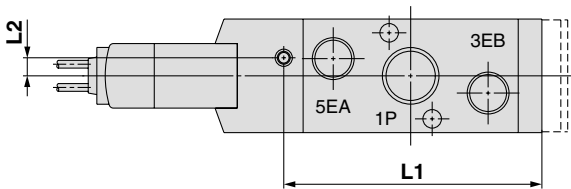

#### • 2-position double

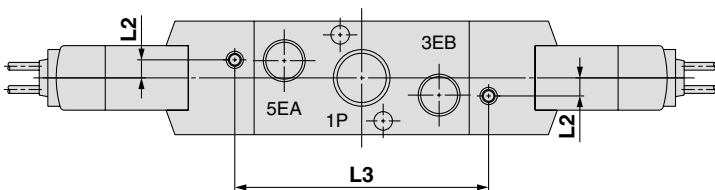

#### • 3-position closed centre/exhaust centre/pressure centre

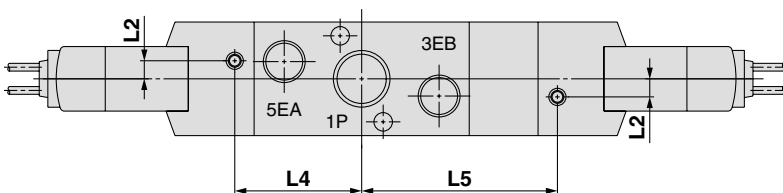

Series	L1	L2	L3	L4	L5
VF1000	34.5	4.2	33.4	—	—
VF3000	60	4.2	59	29.5	45.5
VF5000	95	3.45	89	44.5	63.5



# Pilot Operated 5 Port Solenoid Valve

## Series VF3000/5000

### Single Unit

Base Mounted

#### How to Order Valve



Note) Only DIN and conduit terminal types are available with AC mode. Refer to the electrical entry for details.

Base mounted  
(VF1000: Not available)

**VF 3 1 4 0 K T - 5 G Z D 1 - 02**

**Series**

3	VF3000
5	VF5000

Note) Not available with the VF1000.

**Type of actuation**

1	2-position single
2	2-position double
3	3-position closed centre
4	3-position exhaust centre
5	3-position pressure centre

**Body model**

**Body option**

<b>0: Pilot valve individual exhaust</b>		PE port EA/EB port	VF3000	VF5000
<b>3: Main/Pilot valve common exhaust</b>		PE port EA/EB port	VF3000	VF5000
<b>4: Pilot valve base exhaust</b>		PE port	VF3000	VF5000

**Pressure specification**

—	Standard (0.7 MPa)
K	High-pressure type (1 MPa)

**Coil specification**

—	Standard
T	With power saving circuit (DC only)

Note 1) Be sure to select the power saving circuit type when it is continuously energized for long periods of time. (Refer to back pages 6 and 7 for details.)  
Note 2) T type is available with DC mode only. When T is selected, only Z type of light/surge voltage suppressor is available. (Note that when the electrical entry of DIN terminal type without connector is selected, only DOS and YOS options are available.)

**Rated voltage**

DC	AC (50/60 Hz)
5	24 VDC
6	12 VDC
1	100 VAC
2	200 VAC
3	110 VAC [115 VAC]
4	220 VAC [230 VAC]
7	240 VAC
8	24 VAC

Note) Only DIN and conduit terminal types can be set for AC mode. Refer to electrical entry for details.

**Thread type**

—	Rc
F	G
N	NPT
T	NPTF

**Port size (Sub-plate)**

Symbol	Port size	VF3000	VF5000
—	Without sub-plate	○	○
02	1/4	○	○
03	3/8	○	○
04	1/2	—	○

Note) Without the sub-plate, two mounting screws and gasket are accompanied.

**Manual override**

—: Non-locking push type	D: Push-turn locking slotted type	E: Push-turn locking lever type

**Light/surge voltage suppressor**

Symbol	Light/surge voltage suppressor	DC	AC
—	Without light/surge voltage suppressor	○	○
S	With surge voltage suppressor	○	— <sup>Note 1)</sup>
Z	With light/surge voltage suppressor	○	○
R	With surge voltage suppressor (Non-polar)	○	—
U	With light/surge voltage suppressor (Non-polar)	○	—

Note 1) There is no S option for AC mode, since a rectifier prevents surge voltage generation.  
Note 2) In the DIN terminal type, since a light is installed in the connector, DOZ, DOU, YOZ, YOU options are not available.

**Electrical entry**

	Grommet	L-type plug connector	M-type plug connector	DIN terminal	DIN (EN175301-803) terminal	Conduit terminal
	<b>G:</b> Lead wire length 300 mm <b>H:</b> Lead wire length 600 mm	<b>L:</b> With lead wire (length 300 mm)	<b>M:</b> With lead wire (length 300 mm)	[IP65 compatible]	[IP65 compatible]	[IP65 compatible]
				<b>D:</b> With connector	<b>Y:</b> With connector	<b>T:</b> Conduit terminal
	<b>G:</b> Lead wire length 300 mm <b>H:</b> Lead wire length 600 mm DC Without light/surge voltage suppressor	<b>LN:</b> Without lead wire	<b>MN:</b> Without lead wire			
		<b>LO:</b> Without connector	<b>MO:</b> Without connector	<b>DO:</b> Without connector	<b>YO:</b> Without connector	
DC	○	○	○	○	○	○
AC	—	—	—	○	○	○

### Caution

When using the surge voltage suppressor type, residual voltage will remain. Refer to back page 7 for details.

Note 1) LN and MN types are with 2 sockets.  
Note 2) Refer to back page 4 when different length of lead wire for L/M-type plug connector is required.  
Note 3) Refer to back page 5 for details on the DIN (EN175301-803) terminal.  
Note 4) When using with IP65, select the main/pilot valve common exhaust type or pilot valve base exhaust type.

# Pilot Operated 5 Port Solenoid Valve Base Mounted/Single Unit *Series VF3000/5000*

## Specifications

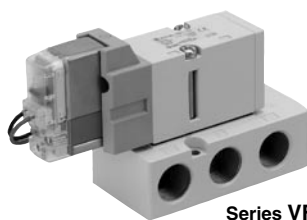

Series VF3000

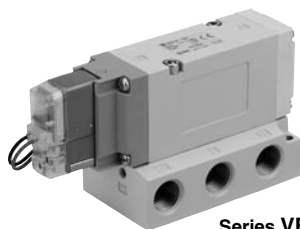

Series VF5000

Model		VF3000	VF5000
Fluid		Air	
Operating pressure range (MPa)	Standard	2-position single/3-position	0.15 to 0.7
		2-position double	0.1 to 0.7
	High-pressure type	2-position single/3-position	0.15 to 1.0
		2-position double	0.1 to 1.0
Ambient and fluid temperature (°C)		-10 to 50 (No freezing)	
Max. operating frequency (Hz)	2-position single/double	10	5
	3-position	3	3
Manual override		Non-locking push type Push-turn locking slotted type Push-turn locking lever type	
Pilot exhaust type		Individual exhaust, Main/ Pilot valve common exhaust	Pilot valve base exhaust
Lubrication		Not required	
Mounting orientation		Unrestricted	
Impact/Vibration resistance (m/s <sup>2</sup> ) <small>Note 1)</small>		300/50	
Enclosure		Dustproof (IP65 <small>Note 2)</small> for D, Y, T)	

Note 1) Impact resistance: No malfunction occurred when it is tested in the axial direction and at the right angles to the main valve and armature in both energized and de-energized states every once for each condition. (Values at the initial period)

Vibration resistance: No malfunction occurred in a one-sweep test between 45 and 2000 Hz. Test was performed at both energized and de-energized states in the axial direction and at the right angles to the main valve and armature. (Values at the initial period)

Note 2) Based on IEC60529. When using with IP65, select the main/pilot valve common exhaust type or pilot valve base exhaust type.

## Solenoid Specifications

Electrical entry		Grommet (G), (H) L-type plug connector (L) M-type plug connector (M)	DIN terminal (D) DIN (EN175301-803) terminal (Y) Conduit terminal (T)
		G, H, L, M	D, Y, T
Coil rated voltage (V)	DC	24, 12	
	AC (50/60 Hz)	—	24, 100, 110, 200, 220, 240
Allowable voltage fluctuation		±10% <small>Note 1,2,3)</small> of rated voltage	
Power consumption (W)	DC	Standard	1.5 (With light: 1.55)
		With power saving circuit	0.55 (With light only)
Apparent power (VA) <small>Note 1,2,3)</small>	AC	100 V	1.55 (With light: 1.7)
		110 V [115 V]	
		200 V	
		220 V [230 V]	
		240 V	
Surge voltage suppressor		Diode (Non-polar type: Varistor)	
Indicator light		LED (Neon bulb is used for AC mode)	

Note 1) It is in common between 110 VAC and 115 VAC, and between 220 VAC and 230 VAC.

Note 2) Allowable voltage fluctuation is -15% to +5% of the rated voltage for 115 VAC or 230 VAC.

Note 3) Since voltage drops due to the internal circuit in S, Z, T types (with power saving circuit), the allowable voltage fluctuation should be within the following range.

24 VDC: -7% to +10%

12 VDC: -4% to +10%

## Response Time

Series	Type of actuation		Pressure specification	Operating pressure range (MPa)	Response time ms (at 0.5 MPa)			
					Without light/surge voltage suppressor	With light/surge voltage suppressor		AC
						S, Z type	R, U type	
VF1000	2-position	Single	Standard	0.15 to 0.7	20	45	23	45
		Double		0.1 to 0.7		12	12	12
		Single	High-pressure type	0.15 to 1.0	23	48	26	48
		Double		0.1 to 1.0		15	15	15
VF3000	2-position	Single	Standard	0.15 to 0.7	20	45	23	45
		Double		0.1 to 0.7		12	12	12
	3-position		High-pressure type	0.15 to 0.7	30	55	33	55
	2-position	Single		0.15 to 1.0		23	26	48
		Double	0.1 to 1.0	15	15	15		
	3-position		Standard	0.15 to 1.0	33	58	36	58
VF5000	2-position	Single		Standard		0.15 to 0.7	30	55
		Double	0.1 to 0.7		15	15		15
	3-position		High-pressure type	0.15 to 0.7	50	75	53	75
	2-position	Single		0.15 to 1.0		33	36	58
Double		0.1 to 1.0	18	18	18			
3-position		Standard	0.15 to 1.0	53	78	56	78	

Note) Based on dynamic performance test, JIS B 8375-1981. (Coil temperature: 20°C, at rated voltage)

# Series VF3000/5000

## Flow-rate Characteristics/Weight

Valve model	Type of actuation		Port size	Flow-rate characteristics <sup>Note 1)</sup>								Weight (g) <sup>Note 2)</sup>	
				1 → 4/2 (P → A/B)				4/2 → 5/3 (A/B → EA/EB)					
				C [dm <sup>3</sup> /s/bar]	b	Cv	Q [l/min] (ANR) <sup>Note 3)</sup>	C [dm <sup>3</sup> /s/bar]	b	Cv	Q [l/min] (ANR) <sup>Note 3)</sup>	Grommet	DIN terminal
VF3□40-02	2-position	Single	1/4	2.8	0.14	0.64	649	2.5	0.18	0.57	592	344 (192)	380 (228)
		Double		2.8	0.14	0.64	649	2.5	0.18	0.57	592	405 (252)	477 (324)
	3-position	Closed centre		2.1	0.22	0.49	509	1.6	0.26	0.41	397	422 (270)	494 (342)
		Exhaust centre		2.3	0.21	0.53	554	2.8 [2.1]	0.23 [0.26]	0.66 [0.50]	682 [521]	422 (270)	494 (342)
		Pressure centre		2.9 [1.1]	0.16 [0.45]	0.67 [0.32]	679 [311]	2.1	0.23	0.49	512	422 (270)	494 (342)
VF3□40-03	2-position	Single	3/8	3.1	0.24	0.76	760	2.6	0.23	0.62	634	327 (192)	363 (228)
		Double		3.1	0.24	0.76	760	2.6	0.23	0.62	634	388 (252)	460 (324)
	3-position	Closed centre		2.2	0.33	0.57	570	1.6	0.34	0.40	418	405 (270)	477 (342)
		Exhaust centre		2.6	0.27	0.61	649	2.8 [2.3]	0.30 [0.28]	0.68 [0.55]	712 [578]	405 (270)	477 (342)
		Pressure centre		3.4 [1.3]	0.29 [0.48]	0.80 [0.38]	859 [376]	2.2	0.31	0.52	563	405 (270)	477 (342)
VF5□44-02	2-position	Single	1/4	7.3	0.49	2.1	2128	7.3	0.50	2.0	2146	486 (297)	522 (333)
		Double		7.3	0.49	2.1	2128	7.3	0.50	2.0	2146	541 (352)	613 (424)
	3-position	Closed centre		6.6	0.35	1.7	1734	6.3	0.31	1.6	1612	578 (390)	650 (462)
		Exhaust centre		7.4	0.33	1.9	1918	8.1 [7.4]	0.35 [0.34]	2.1 [1.9]	2128 [1931]	578 (390)	650 (462)
		Pressure centre		8.0 [2.9]	0.35 [0.48]	2.1 [0.85]	2102 [839]	5.6	0.31	1.5	1433	578 (390)	650 (462)
VF5□44-03	2-position	Single	3/8	8.4	0.34	2.2	2192	8.9	0.29	2.3	2249	473 (297)	509 (333)
		Double		8.4	0.34	2.2	2192	8.9	0.29	2.3	2249	529 (352)	601 (424)
	3-position	Closed centre		7.3	0.34	2.0	1905	7.1	0.28	1.8	1783	566 (390)	638 (462)
		Exhaust centre		8.1	0.27	2.0	2022	14.0 [8.3]	0.26 [0.31]	3.4 [2.2]	3473 [2124]	566 (390)	638 (462)
		Pressure centre		8.1 [2.5]	0.33 [0.48]	2.0 [0.74]	2100 [723]	5.7	0.31	1.4	1459	566 (390)	638 (462)
VF5□44-04	2-position	Single	1/2	9.4	0.43	2.7	2614	12.0	0.32	3.0	3091	545 (297)	581 (333)
		Double		9.4	0.43	2.7	2614	12.0	0.32	3.0	3091	600 (352)	672 (424)
	3-position	Closed centre		7.1	0.41	2.1	1945	7.4	0.32	2.0	1906	638 (390)	710 (462)
		Exhaust centre		8.6	0.39	2.4	2323	13.0 [8.9]	0.21 [0.40]	3.1 [2.5]	3132 [2421]	638 (390)	710 (462)
		Pressure centre		11.0 [2.6]	0.18 [0.47]	2.6 [0.78]	2606 [746]	6.1	0.35	1.6	1603	638 (390)	710 (462)

Note 1) [ ]: Normal position

Note 2) Values without bracket

Note 3) These valves have been calculated according to ISO6358 and indicate the flow rate under standard conditions with an inlet pressure of 0.6 MPa (relative pressure) and a pressure drop of 0.1 MPa.

**Construction/Base Mounted**

**VF3000/5000**

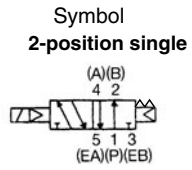

**2-position single**

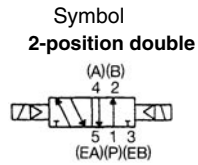
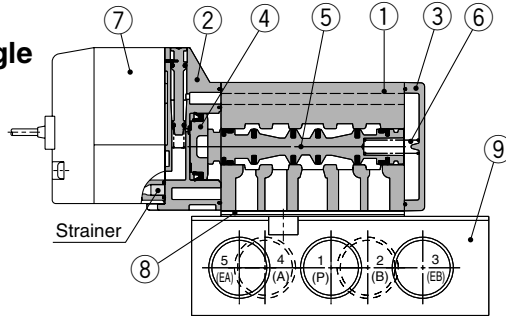

**2-position double**

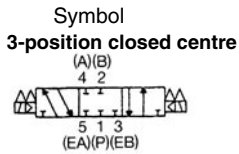
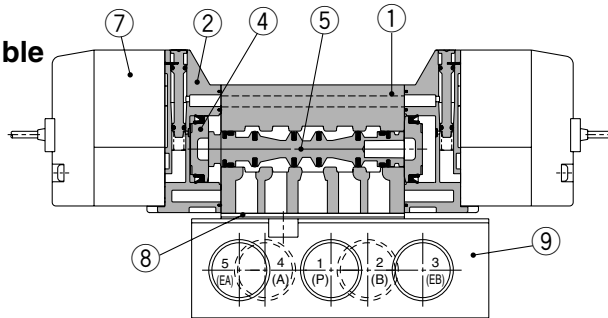

**3-position closed centre/exhaust centre/pressure centre**

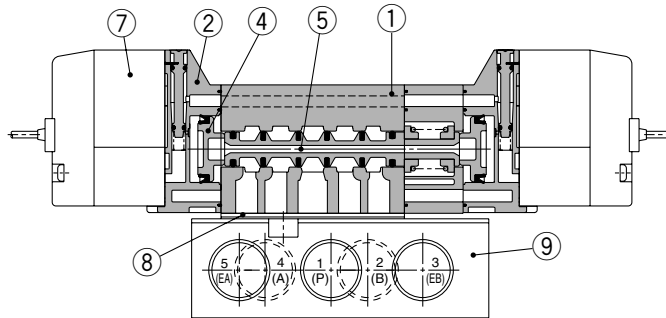

(Drawing shows a closed centre type.)

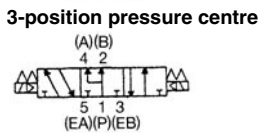
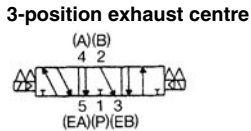

Sub-plate part no.

**VF 3 000-71-1**

Series

3	VF3000
5	VF5000

Thread type

—	Rc
F	G
N	NPT
T	NPTF

Port size

Symbol	Port size	VF3000	VF5000
1	1/4	○	○
2	3/8	○	○
3	1/2	—	○

**Component Parts**

No.	Description	Material	Note
1	Body	Aluminum die-casted	White
2	Adapter plate	Resin	Grey
3	End plate	Aluminum die-casted (VF5000: Resin)	White
4	Piston	Resin	
5	Spool valve	Aluminum, HNBR	
6	Spring	Stainless steel	

**Replacement Parts**

No.	Description	Part no.		Note
		VF3000	VF5000	
7	Pilot valve assembly	Refer to "How to Order Pilot Valve Assembly" on page 19.		Built-in strainer
8	Gasket	DXT031-30-11	DXT156-9-8	HNBR
9	Sub-plate	1/8: VF3000-71-1□ 1/4: VF3000-71-2□	1/4: VF5000-71-1□ 3/8: VF5000-71-2□ 1/2: VF5000-71-3□	Aluminum die-casted
—	Round head combination screw (1 pc.)	DXT031-44-1 (With M4 x 39.5 SW)	—	For valve mounting
—	Hexagon socket head cap screw (1 pc.)	—	AXT620-32-1 (With M4 x 48 SW)	For valve mounting

**Caution**

**Tightening Torque of Valve Mounting**

M4: 1.4 N·m

# Series VF3000/5000

## How to Order Pilot Valve Assembly

### ⚠ Caution

When only the pilot valve assembly is replaced, it is not possible to change from V211 (Grommet or L/M-type) to V212 (DIN or Conduit type), or vice versa.

Valve model: VF□□□□□□ - 5 G Z □ 1 - □□□

Note) Select from the below in accordance with the valve used.

#### ■ Grommet or L/M-type

V 2 1 1 □□ - 5 G Z

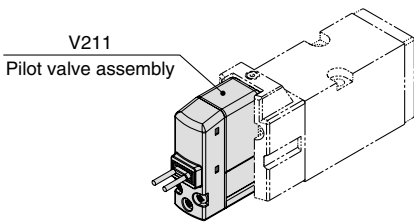

#### ● Light/surge voltage suppressor

—	Without light/surge voltage suppressor
S	With surge voltage suppressor
Z	With light/surge voltage suppressor
R	With surge voltage suppressor (Non-polar)
U	With light/surge voltage suppressor (Non-polar)

Note) When T is selected, only Z type of light/surge voltage suppressor is available.

### ⚠ Caution

When using the surge voltage suppressor type, residual voltage will remain. Refer to back page 7 for details.

#### ● Electrical entry

G	Grommet (Lead wire length 300 mm)	
H	Grommet (Lead wire length 600 mm)	
L	L-type plug connector	With lead wire
LN		Without lead wire
LO	M-type plug connector	Without connector
M		With lead wire
MN		Without lead wire
MO		Without connector

Note 1) LN and MN types are with 2 sockets.

Note 2) Refer to back page 4 when different length of lead wire for L/M-type plug connector is required.

#### ■ DIN or Conduit type

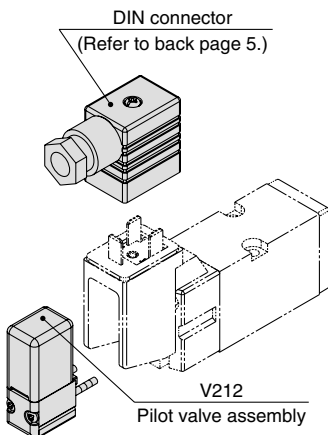

V 2 1 2 □□ - 5

#### ● Pressure specification

—	Standard (0.7 MPa)
K	High-pressure type (1 MPa)

#### ● Coil specification

—	Standard
T	With power saving circuit (DC only)

Note) T type is available with DC mode only.

#### ● Rated voltage

DC	
5	24 VDC
6	12 VDC

#### AC (50/60 Hz)

1	100 VAC
2	200 VAC
3	110 VAC [115 VAC]
4	220 VAC [230 VAC]
7	240 VAC
8	24 VAC

Note) Only V212 type can be set for AC mode. V211 type can not be set for AC mode.

### ⚠ Caution

For V212 (DIN or Conduit type), the coil specification and voltage (including light/surge voltage suppressor) cannot be changed by changing the pilot valve assembly.

### ⚠ Caution

Tightening torque of the pilot valve assembly mounting screw  
M2.5: 0.32 N·m



**Series VF3000/Base Mounted/Dimensions**

**2-position single**

**Grommet (G) (H): VF3140-□<sup>G</sup>□□-02□**

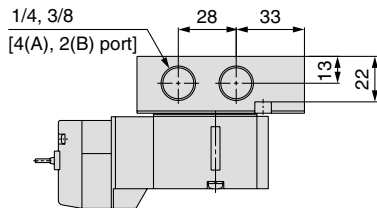
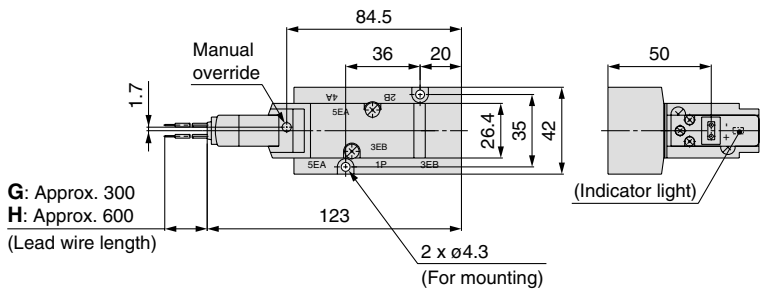
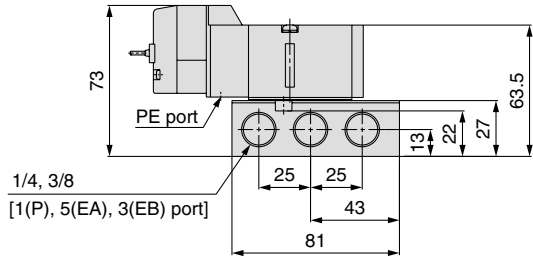

**Grommet (G) (H)  
DC without light/surge voltage suppressor**

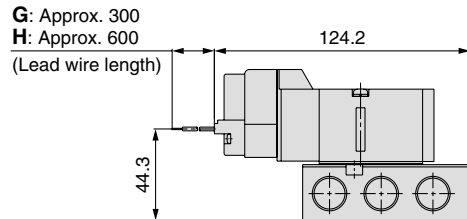

**L-type plug connector (L): VF3140-□L□□-02□**

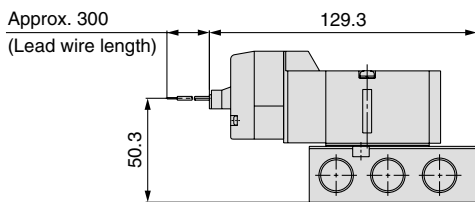

Unless otherwise indicated, dimensions are the same as Grommet (G).

**DIN terminal (D) (Y): VF3140-□<sup>D</sup>□□-02□**

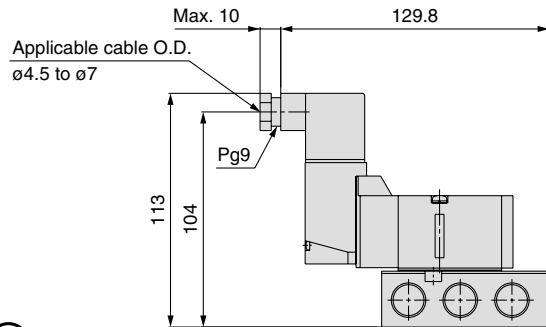

Unless otherwise indicated, dimensions are the same as Grommet (G).

**M-type plug connector (M): VF3140-□M□□-02□**

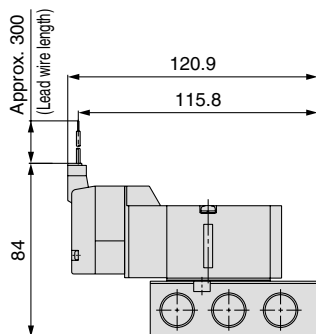

Unless otherwise indicated, dimensions are the same as Grommet (G).

**Conduit terminal (T): VF3140-□T□□-02□**

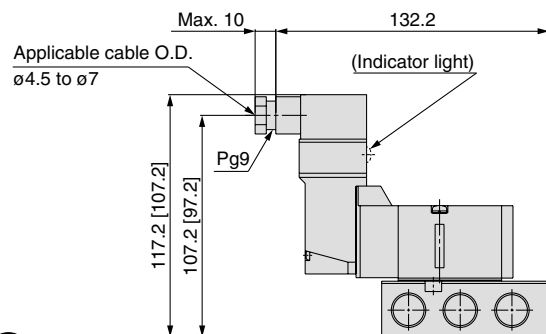

[ ]: Without indicator light  
Unless otherwise indicated, dimensions are the same as Grommet (G).

# Series VF3000/5000

## Series VF3000/Base Mounted/Dimensions

### 2-position double

Grommet (G) (H): VF3240-□<sup>G</sup>□□-02□<sub>03</sub>□

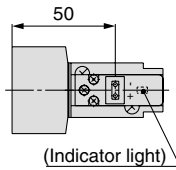
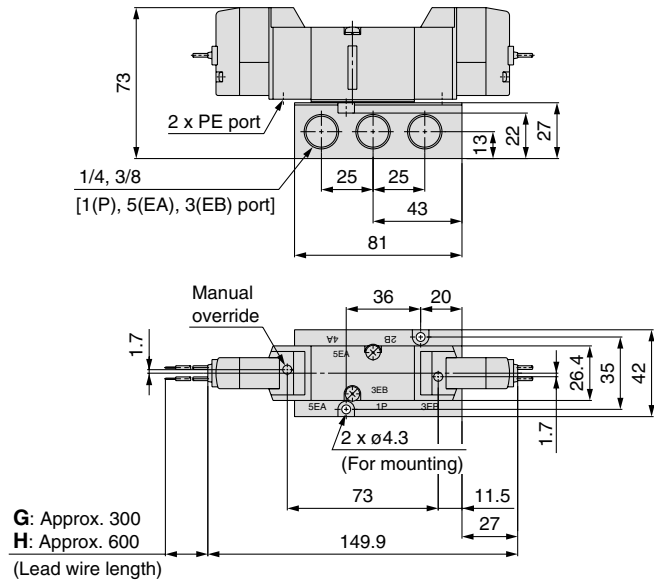

### Grommet (G) (H) DC without light/surge voltage suppressor

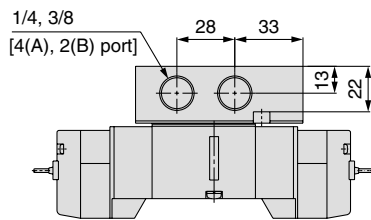
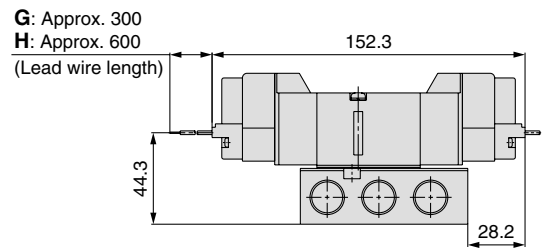

### L-type plug connector (L): VF3240-□L□□-02□<sub>03</sub>□

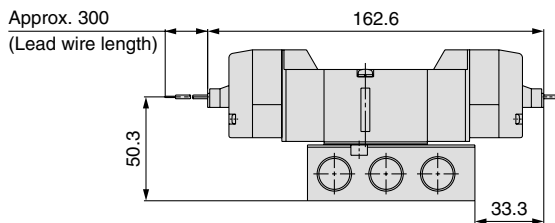

Unless otherwise indicated, dimensions are the same as Grommet (G).

### DIN terminal (D) (Y): VF3240-□<sup>D</sup>□□-02□<sub>03</sub>□

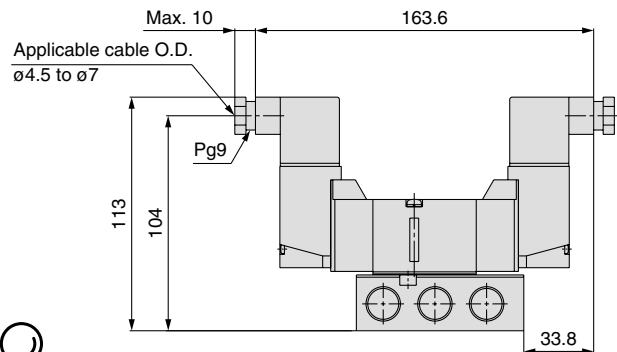

Unless otherwise indicated, dimensions are the same as Grommet (G).

### M-type plug connector (M): VF3240-□M□□-02□<sub>03</sub>□

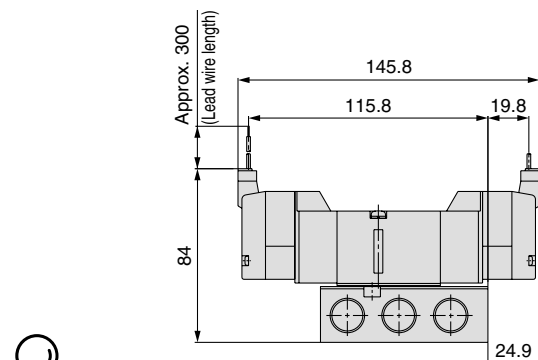

Unless otherwise indicated, dimensions are the same as Grommet (G).

### Conduit terminal (T): VF3240-□T□□-02□<sub>03</sub>□

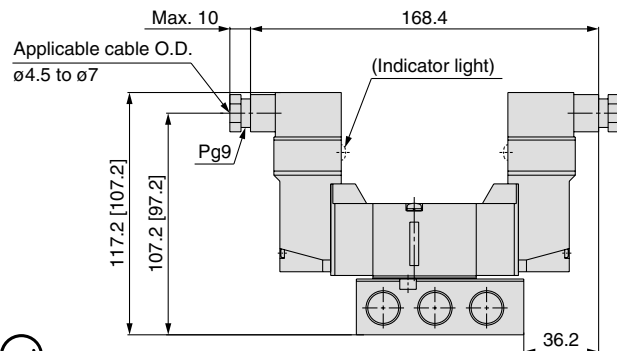

[ ]: Without indicator light  
Unless otherwise indicated, dimensions are the same as Grommet (G).

**Series VF3000/Base Mounted/Dimensions**

3-position closed centre/exhaust centre/pressure centre

Grommet (G) (H): VF3<sup>3</sup><sub>5</sub>440-□ G □ □ - 02 □  
□ H □ □ - 03 □

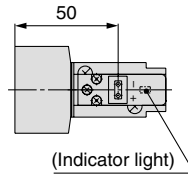
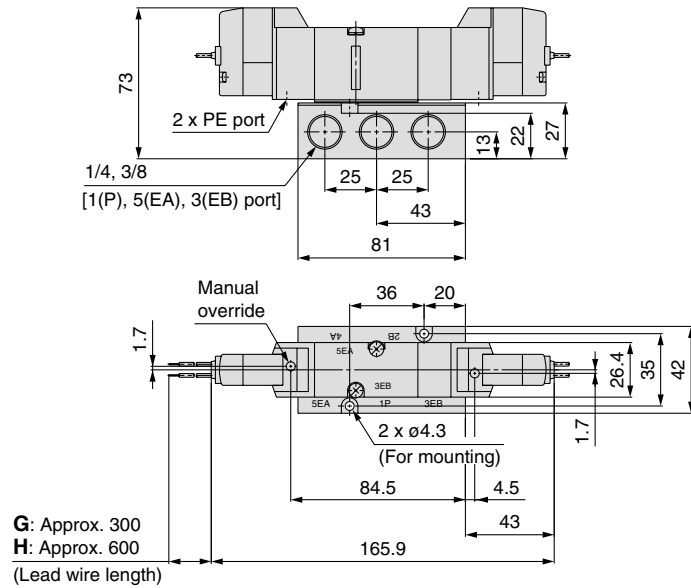

**Grommet (G) (H)**  
DC without light/surge voltage suppressor

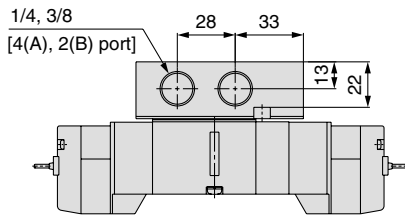
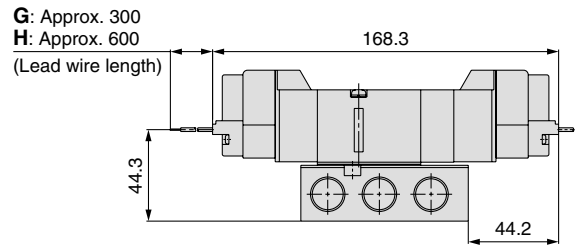

L-type plug connector (L): VF3<sup>3</sup><sub>5</sub>440-□ L □ □ - 02 □  
□ □ □ □ - 03 □

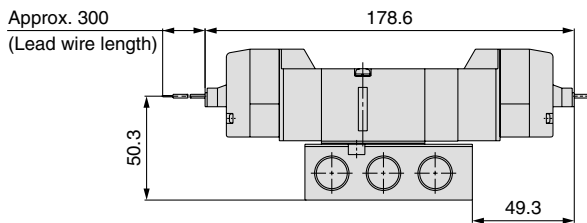

Unless otherwise indicated, dimensions are the same as Grommet (G).

DIN terminal (D) (Y): VF3<sup>3</sup><sub>5</sub>440-□ D □ □ - 02 □  
□ □ □ □ - 03 □

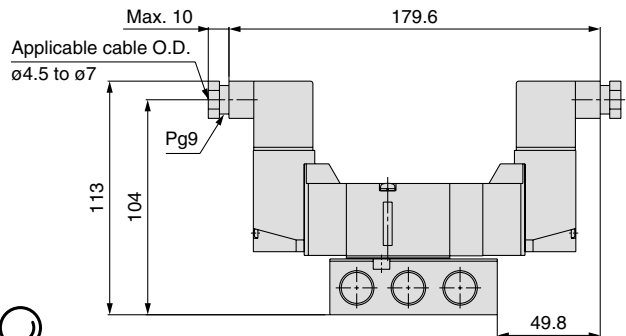

Unless otherwise indicated, dimensions are the same as Grommet (G).

M-type plug connector (M): VF3<sup>3</sup><sub>5</sub>440-□ M □ □ - 02 □  
□ □ □ □ - 03 □

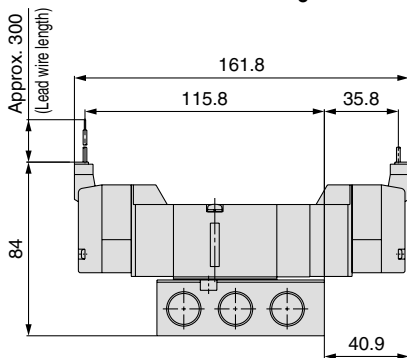

Unless otherwise indicated, dimensions are the same as Grommet (G).

Conduit terminal (T): VF3<sup>3</sup><sub>5</sub>440-□ T □ □ - 02 □  
□ □ □ □ - 03 □

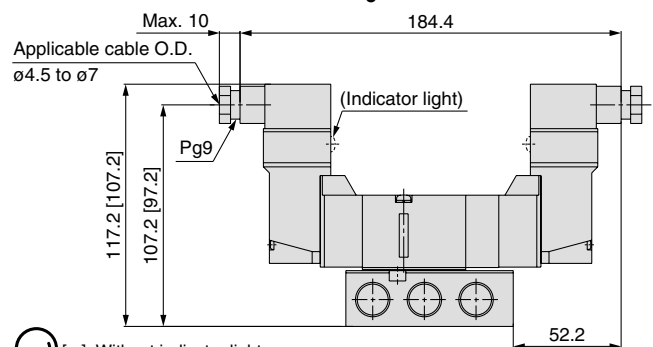

[ ]: Without indicator light  
Unless otherwise indicated, dimensions are the same as Grommet (G).

# Series VF3000/5000

## Series VF5000/Base Mounted/Dimensions

### 2-position single

Grommet (G) (H): VF5144-□<sup>G</sup><sub>H</sub>□□-<sup>02</sup><sub>03</sub>□<sup>04</sup>

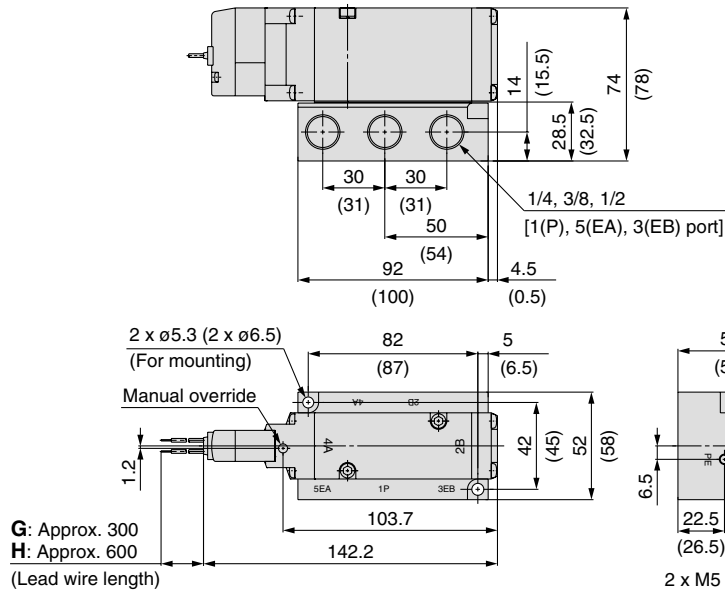

G: Approx. 300  
H: Approx. 600  
(Lead wire length)

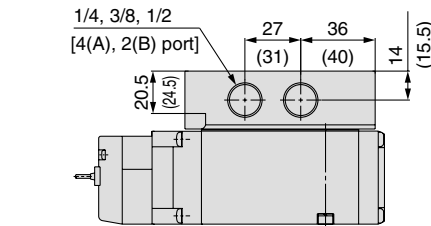

The dimensions in ( ) are for 1/2 piping port size.

### Grommet (G) (H) DC without light/surge voltage suppressor

G: Approx. 300  
H: Approx. 600  
(Lead wire length)

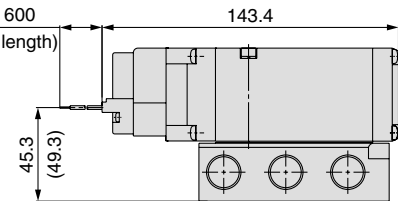

### L-type plug connector (L): VF5144-□L□□-<sup>02</sup><sub>03</sub>□<sup>04</sup>

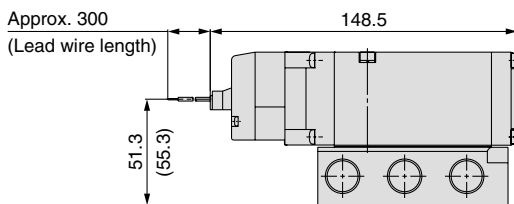

Unless otherwise indicated, dimensions are the same as Grommet (G).  
The dimensions in ( ) are for 1/2 piping port size.

### DIN terminal (D) (Y): VF5144-□<sup>D</sup><sub>Y</sub>□□-<sup>02</sup><sub>03</sub>□<sup>04</sup>

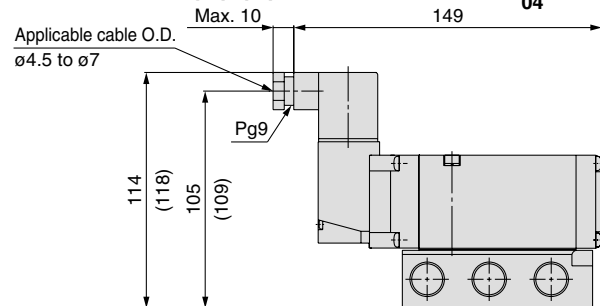

Unless otherwise indicated, dimensions are the same as Grommet (G).  
The dimensions in ( ) are for 1/2 piping port size.

### M-type plug connector (M): VF5144-□M□□-<sup>02</sup><sub>03</sub>□<sup>04</sup>

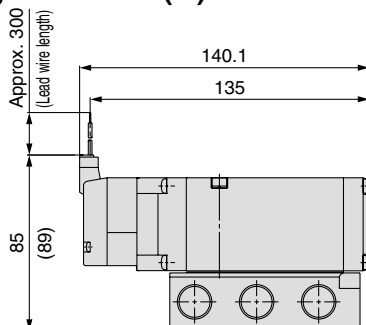

Unless otherwise indicated, dimensions are the same as Grommet (G).  
The dimensions in ( ) are for 1/2 piping port size.

### Conduit terminal (T): VF5144-□T□□-<sup>02</sup><sub>03</sub>□<sup>04</sup>

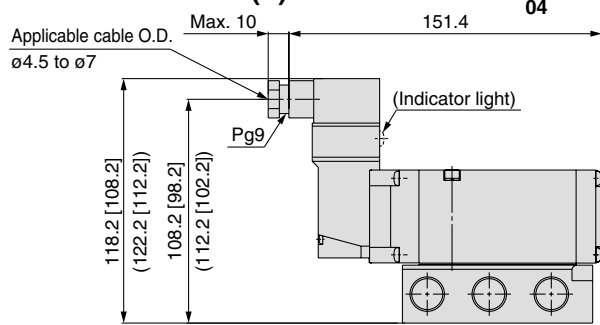

Unless otherwise indicated, dimensions are the same as Grommet (G).  
[ ] : Without indicator light  
The dimensions in ( ) are for 1/2 piping port size.

**Series VF5000/Base Mounted/Dimensions**

**2-position double**

Grommet (G) (H): VF5244-□<sup>G</sup>□□-<sup>02</sup><sub>03</sub>□<sub>04</sub>

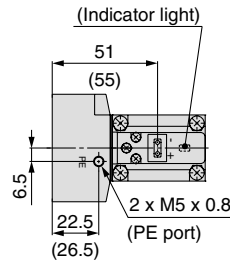
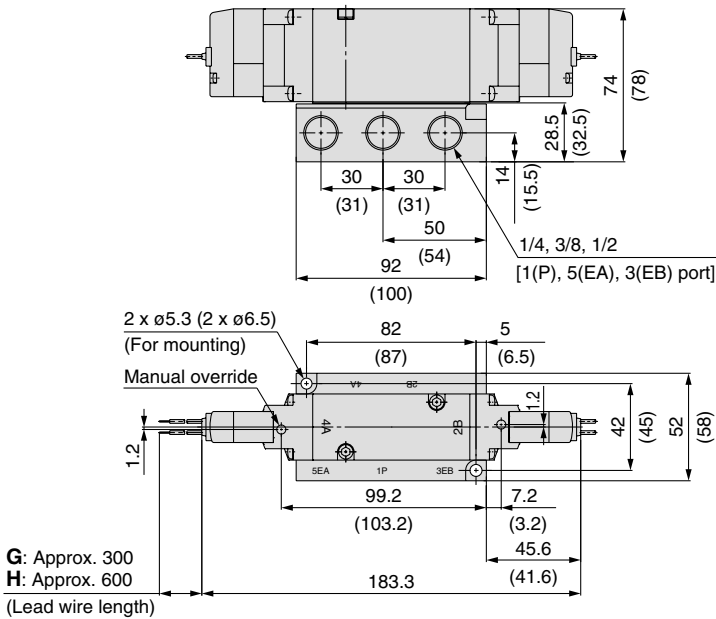

**Grommet (G) (H)**  
DC without light/surge voltage suppressor

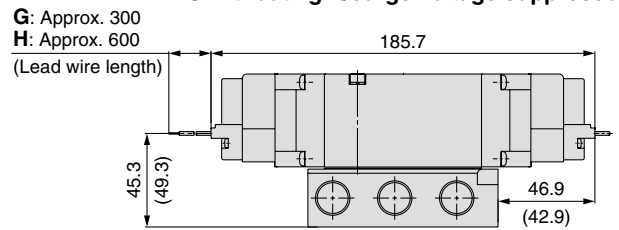

The dimensions in ( ) are for 1/2 piping port size.

**L-type plug connector (L): VF5244-□L□□-<sup>02</sup><sub>03</sub>□<sub>04</sub>**

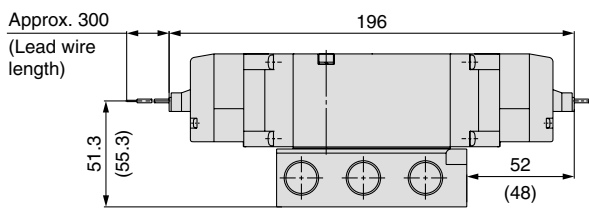

Unless otherwise indicated, dimensions are the same as Grommet (G). The dimensions in ( ) are for 1/2 piping port size.

**DIN terminal (D) (Y): VF5244-□<sup>D</sup>□□-<sup>02</sup><sub>03</sub>□<sub>04</sub>**

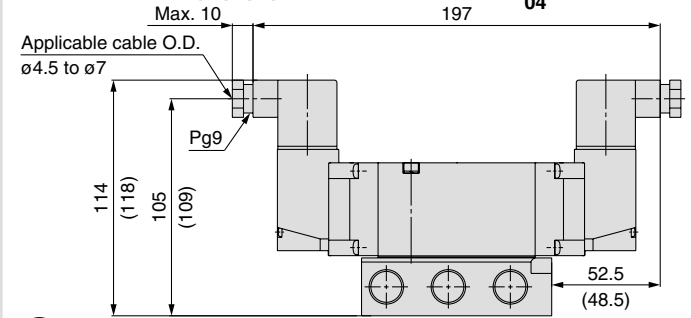

Unless otherwise indicated, dimensions are the same as Grommet (G). The dimensions in ( ) are for 1/2 piping port size.

**M-type plug connector (M): VF5244-□M□□-<sup>02</sup><sub>03</sub>□<sub>04</sub>**

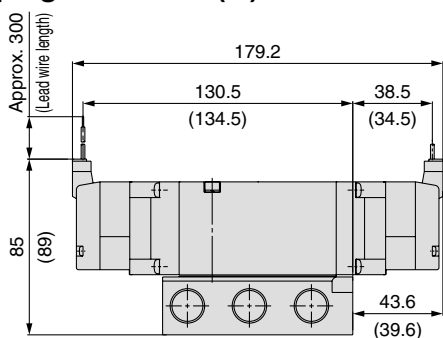

Unless otherwise indicated, dimensions are the same as Grommet (G). The dimensions in ( ) are for 1/2 piping port size.

**Conduit terminal (T): VF5244-□T□□-<sup>02</sup><sub>03</sub>□<sub>04</sub>**

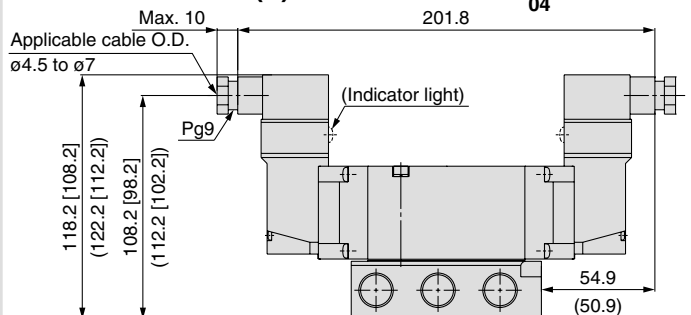

Unless otherwise indicated, dimensions are the same as Grommet (G). [ ] : Without indicator light. The dimensions in ( ) are for 1/2 piping port size.

# Series VF3000/5000

## Series VF5000/Base Mounted/Dimensions

### 3-position closed centre/exhaust centre/pressure centre

Grommet (G) (H): VF5<sup>3</sup><sub>444</sub>-□<sup>G</sup><sub>H</sub>□□-<sup>02</sup><sub>03</sub>□<sup>04</sup>

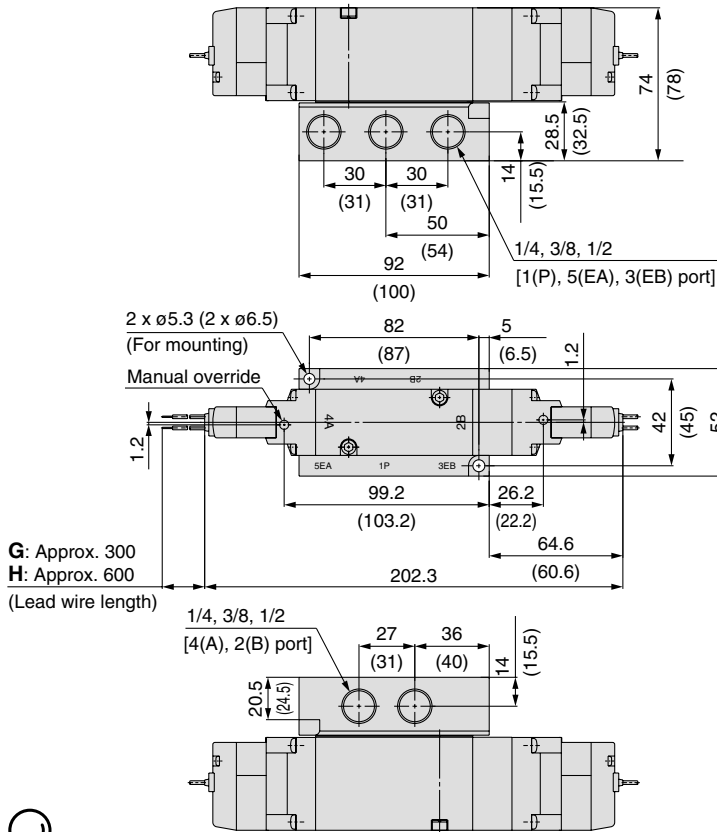

G: Approx. 300  
H: Approx. 600  
(Lead wire length)

**Grommet (G) (H)**  
DC without light/surge voltage suppressor

G: Approx. 300  
H: Approx. 600  
(Lead wire length)

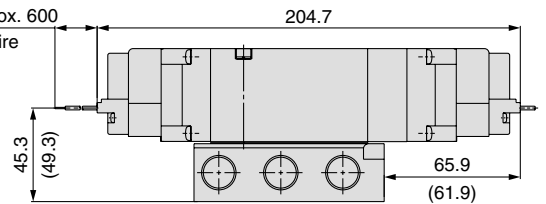

The dimensions in ( ) are for 1/2 piping port size.

L-type plug connector (L): VF5<sup>3</sup><sub>444</sub>-□<sup>L</sup>□□-<sup>02</sup><sub>03</sub>□<sup>04</sup>

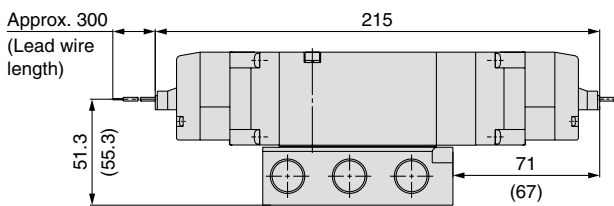

Unless otherwise indicated, dimensions are the same as Grommet (G).  
The dimensions in ( ) are for 1/2 piping port size.

DIN terminal (D) (Y): VF5<sup>3</sup><sub>444</sub>-□<sup>D</sup><sub>Y</sub>□□-<sup>02</sup><sub>03</sub>□<sup>04</sup>

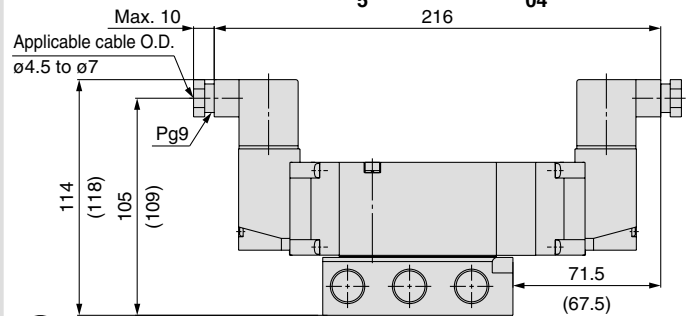

Unless otherwise indicated, dimensions are the same as Grommet (G).  
The dimensions in ( ) are for 1/2 piping port size.

M-type plug connector (M): VF5<sup>3</sup><sub>444</sub>-□<sup>M</sup>□□-<sup>02</sup><sub>03</sub>□<sup>04</sup>

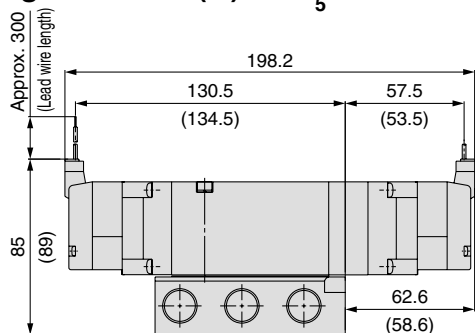

Unless otherwise indicated, dimensions are the same as Grommet (G).  
The dimensions in ( ) are for 1/2 piping port size.

Conduit terminal (T): VF5<sup>3</sup><sub>444</sub>-□<sup>T</sup>□□-<sup>02</sup><sub>03</sub>□<sup>04</sup>

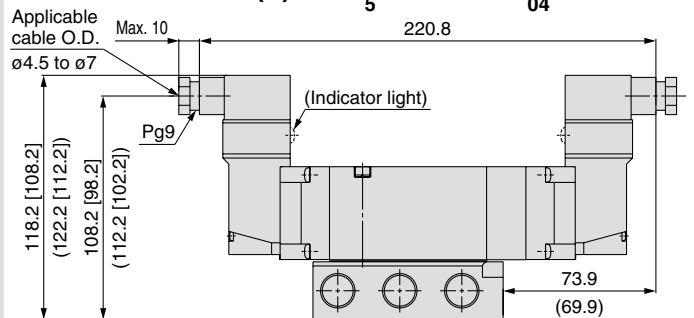

Unless otherwise indicated, dimensions are the same as Grommet (G).  
[ ]: Without indicator light  
The dimensions in ( ) are for 1/2 piping port size.



# Pilot Operated 5 Port Solenoid Valve Series VF1000/3000/5000 Manifold

Body Ported

## How to Order Manifold



Note) Only DIN and conduit terminal types are available with AC mode.  
Refer to the electrical entry for details.

### Common exhaust

VV5F 1 - 30 - 04 1 -

Series	1 VF1000	3 VF3000	5 VF5000	
Manifold model				
Symbol	P, R port size	VF1000	VF3000	VF5000
30	1/8	○	—	—
	1/4	—	○	—
20	3/8	—	—	○
21	1/2	—	—	○

Stations	02 2 stations	20 20 stations
⋮	⋮	⋮

Note) Up to 10 stations for VV5F5-20, and up to 15 stations for VV5F5-21.

### Individual exhaust (VF1000 only)

VV5F1 - 31 - 04 3 -

Stations	02 2 stations	20 20 stations		
⋮	⋮	⋮		
Thread type	— Rc	00F G	00N NPT	00T NPTF
Manifold model				
Symbol	P, R port size	EA, EB port size		
31	1/8	M5		

Note) The A and B ports are made on the top.

## How to Order Valve (With a gasket and two mounting screws)

VF 3 1 3 0 - 5 G 1 - 01

Series	1 VF1000	3 VF3000	5 VF5000		
Type of actuation	1 2-position single	2 2-position double	3 3-position closed centre	4 3-position exhaust centre	5 3-position pressure centre

Note) Only 1 and 2 are available with the VF1000.

Coil specification	— Standard	T With power saving circuit (DC only)
--------------------	------------	---------------------------------------

Note 1) Be sure to select the power saving circuit type when it is continuously energized for long periods of time. (Refer to back pages 6 and 7 for details.)

Note 2) T type is available with DC mode only. When T is selected, only Z type of light/surge voltage suppressor is available. (Note that when the electrical entry of DIN terminal type without connector is selected, only DOS and YOS options are available.)

A, B port size	Symbol	Port size	VF1000	VF3000	VF5000
M5	M5 x 0.8	○	—	—	—
01	1/8	○	○	—	—
02	1/4	—	○	○	—
03	3/8	—	—	○	—

Thread type	— Rc	F G	N NPT	T NPTF
-------------	------	-----	-------	--------

Note) M5 is only available with "—" option.

### Body option

0: Pilot valve individual exhaust	3: Main/Pilot valve common exhaust
PE port EA/EB port	PE port EA/EB port
VF1000 VF3000 VF5000	VF1000 VF3000 VF5000
○ ○ ○	○ ○ ○

Pressure specification	— Standard (0.7 MPa)	K High-pressure type (1 MPa)
------------------------	----------------------	------------------------------

### Rated voltage

DC	AC (50/60 Hz)	
5 24 VDC	1 100 VAC	4 220 VAC [230 VAC]
6 12 VDC	2 200 VAC	7 240 VAC
	3 110 VAC [115 VAC]	8 24 VAC

Note) Only DIN and conduit terminal types can be set for AC mode. Refer to electrical entry for details.

### Body model

Symbol	VF1000	VF3000	VF5000
2	—	—	○
3	○	○	—

Note) Manifold only

### Light/surge voltage suppressor

Symbol	Light/surge voltage suppressor	DC	AC
—	Without light/surge voltage suppressor	○	○
S	With surge voltage suppressor	○	Note 1)
Z	With light/surge voltage suppressor	○	○
R	With surge voltage suppressor (Non-polar)	○	—
U	With light/surge voltage suppressor (Non-polar)	○	—

Note 1) There is no S option for AC mode, since a rectifier prevents surge voltage generation.

Note 2) In the DIN terminal type, since a light is installed in the connector, DOZ, DOU, YOZ, YOU options are not available.

### Manual override

—: Non-locking push type

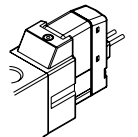

D: Push-turn locking slotted type

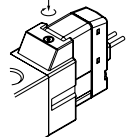

E: Push-turn locking lever type

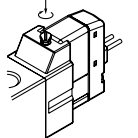

### Electrical entry

	Grommet		L-type plug connector		M-type plug connector		DIN terminal	DIN (EN175301-803) terminal	Conduit terminal
	G: Lead wire length 300 mm	G: Lead wire length 300 mm	L: With lead wire (length 300 mm)	LN: Without lead wire	M: With lead wire (length 300 mm)	MN: Without lead wire	D: With connector	Y: With connector	T: Conduit terminal
	H: Lead wire length 600 mm	H: Lead wire length 600 mm	LO: Without connector		MO: Without connector		DO: Without connector	YO: Without connector	
DC	○	○	○	○	○	○	○	○	○
AC	—	—	—	—	—	—	—	—	—

Note 1) LN and MN types are with 2 sockets.

Note 2) Refer to back page 4 when different length of lead wire for L/M-type plug connector is required.

Note 3) Refer to back page 5 for details on the DIN (EN175301-803) terminal.

Note 4) When using with IP65, select the main/pilot valve common exhaust type.

### Caution

When using the surge voltage suppressor type, residual voltage will remain. Refer to back page 7 for details.



# Pilot Operated 5 Port Solenoid Valve Body Ported/Manifold *Series VF1000/3000/5000*

## Manifold Specifications

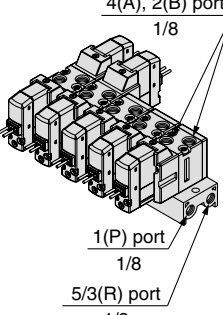
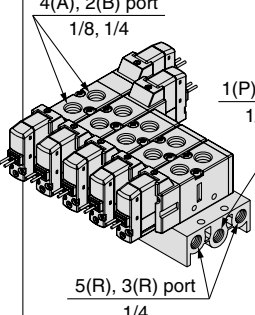
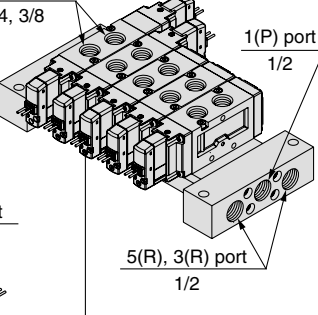
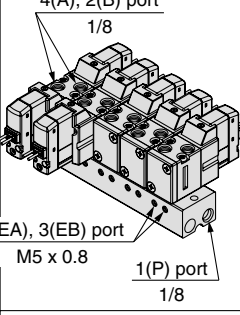
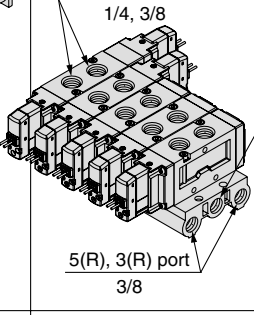
Series	VF1000		VF3000	VF5000	
Manifold base model	<b>VV5F1-30</b> 		<b>VV5F3-30</b> 	<b>VV5F5-21</b> 	
	<b>VV5F1-31</b> 			<b>VV5F5-20</b> 	
EXH port type	Common EXH	Individual EXH	Common EXH	Common EXH	Common EXH
Applicable valve model	<b>VF1□30</b> <b>VF1□33</b>		<b>VF3□30</b> <b>VF3□33</b>	<b>VF5□20</b> <b>VF5□23</b>	
Applicable stations	2 to 20 stations		2 to 20 stations	2 to 10 stations	2 to 15 stations
Manifold base Weight: W [g] Stations: n	W = 29n + 21	W = 51n + 35	W = 64 + 63n	W = 97n + 80	W = 139n + 550

Note) Supply pressure to 1(P) ports and exhaust pressure from R ports on both sides for 10 stations or more (5 stations or more for the VF5000).

## How to Order Manifold Assembly

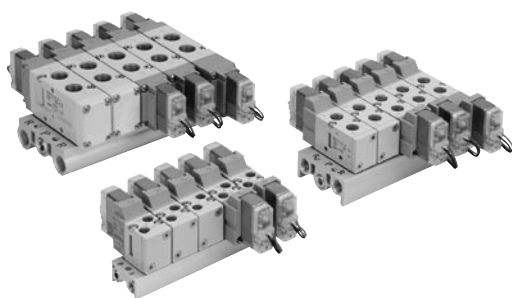

### Example (VV5F3-30)

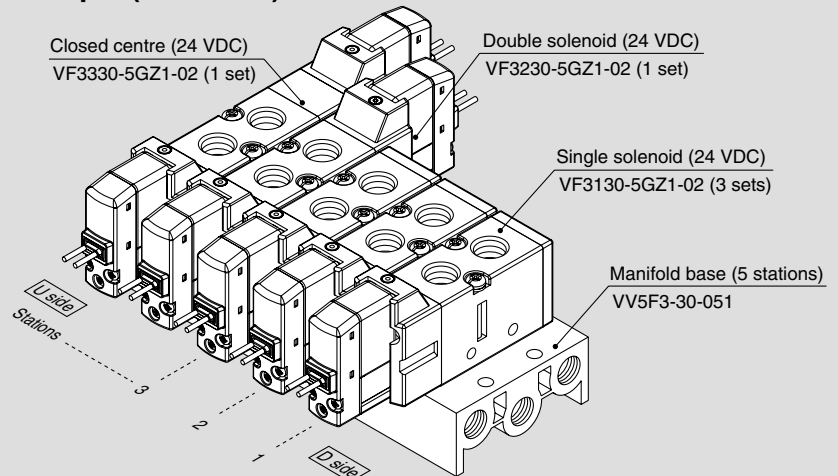

- VV5F3-30-051** ..... 1 set (Type 30, 5-station manifold base part no.)  
 \* **VF3130-5GZ1-02** ..... 3 sets (Single solenoid part no.)  
 \* **VF3230-5GZ1-02** ..... 1 set (Double solenoid part no.)  
 \* **VF3330-5GZ1-02** ..... 1 set (Closed centre part no.)  
 ↳ The asterisk denotes the symbol for assembly. Prefix it to the part nos. of the solenoid valve, etc.

- The valve arrangement is numbered as the 1st station from D side.
- Indicate the valves to be attached below the manifold base part number, in order starting from station 1 as shown in the drawing. If the arrangement becomes complicated, then indicate on the manifold specification sheet.

# Series VF1000/3000/5000

## Manifold Options

### ■ For body ported Blanking plate assembly

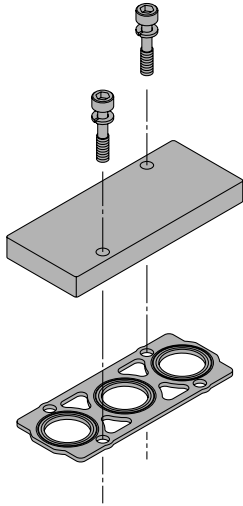

Series	Blanking plate assembly part no.
<b>VF1000</b>	DXT144-13-3A
<b>VF3000</b>	DXT031-38-5A
<b>VF5000</b>	VF5000-70-1A

### ■ Mounting screw, gasket part no.

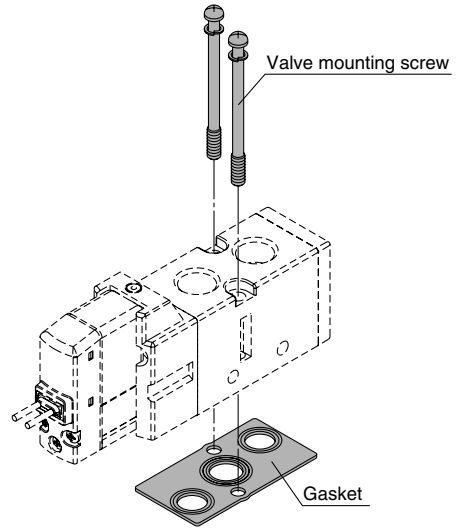

Series	Valve mounting screw (1 pc.)	Gasket
<b>VF1000</b>	Round head combination screw DXT031-44-1 (With M4 x 39.5 SW)	DXT144-12-2
<b>VF3000</b>		DXT155-25-7
<b>VF5000</b>	Hexagon socket head cap screw AXT620-32-1 (With M4 x 48 SW)	DXT156-9-6

### ■ Individual EXH spacer assembly

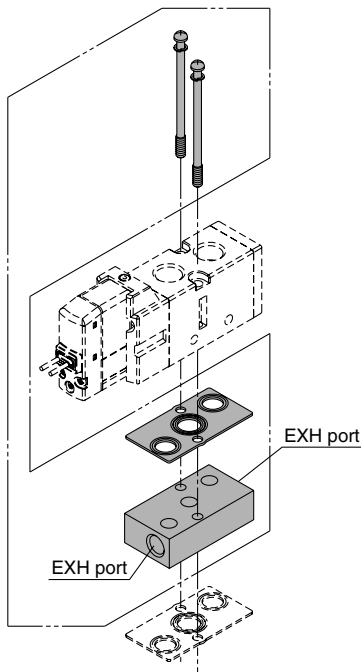

### ⚠ Caution

#### Tightening Torque of Mounting Screw

M4: 1.4 N·m

### ⚠ Warning

When mounting a valve or spacer on the manifold base or sub-plate, etc., the mounting orientation is already decided. If mounted in a wrong direction, the equipment to be connected may result in malfunction. Refer to external dimensions in mounting.

VF **3** 000-75-1 **A**

#### • Series

Symbol	Series	Port size
<b>3</b>	VF3000	1/8
<b>5</b>	VF5000	1/4

#### • Thread type

—	Rc
<b>F</b>	G
<b>N</b>	NPT
<b>T</b>	NPTF

# Pilot Operated 5 Port Solenoid Valve Body Ported/Manifold *Series VF1000/3000/5000*

## Series VF1000/Dimensions

Type 30/VV5F1-30-□□1-□: Common exhaust  
Grommet (G) (H)

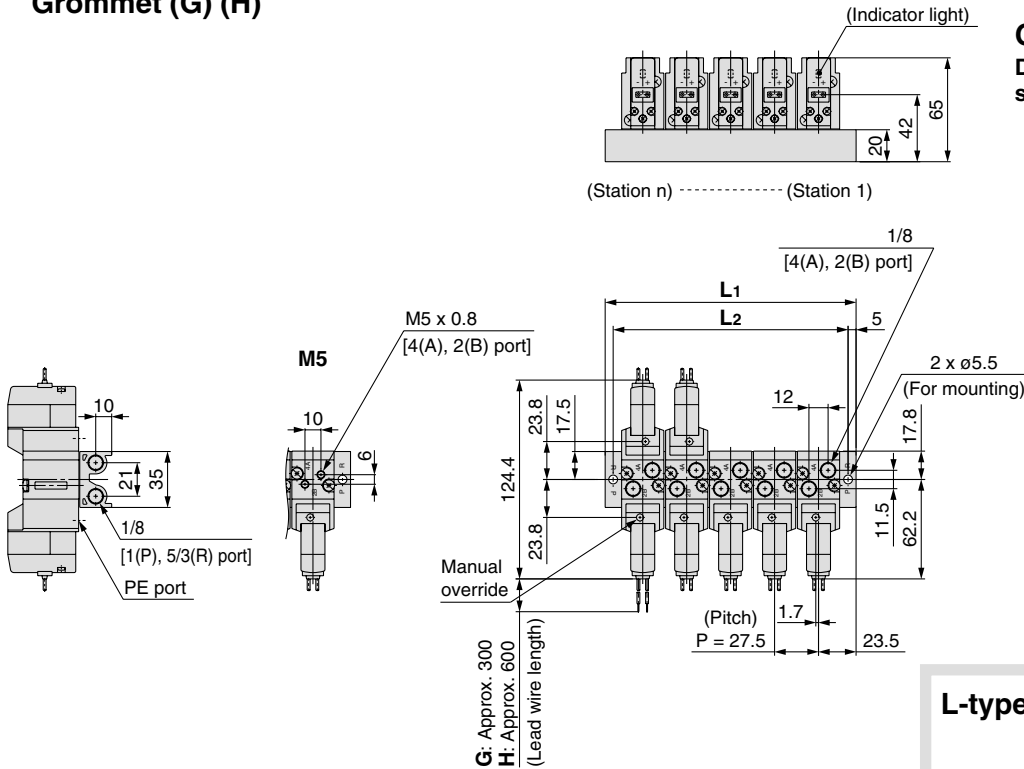

**Grommet (G) (H)**  
DC without light/  
surge voltage suppressor

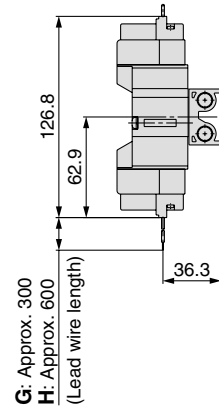

### L: Dimensions

L \ n	2	3	4	5	6	7	8	9	10	11	12	13	14
L1	74.5	102	129.5	157	184.5	212	239.5	267	294.5	322	349.5	377	404.5
L2	64.5	92	119.5	147	174.5	202	229.5	257	284.5	312	339.5	367	394.5

L \ n	15	16	17	18	19	20
L1	432	459.5	487	514.5	542	569.5
L2	422	449.5	477	504.5	532	559.5

### L-type plug connector (L)

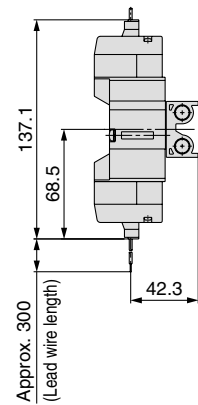

Unless otherwise indicated, dimensions are the same as Grommet (G).

### M-type plug connector (M)

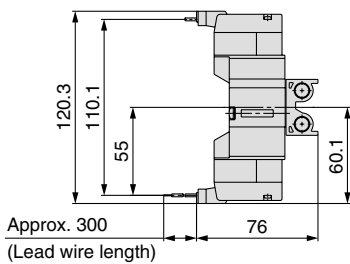

Unless otherwise indicated, dimensions are the same as Grommet (G).

### DIN terminal (D) (Y)

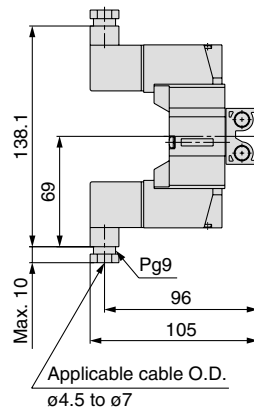

Unless otherwise indicated, dimensions are the same as Grommet (G).

### Conduit terminal (T)

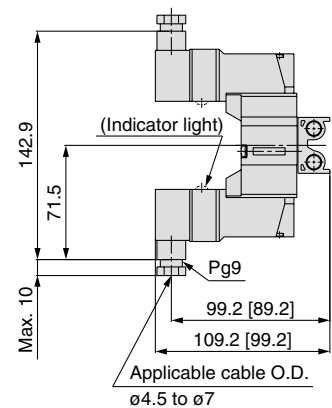

[ ]: Without indicator light  
Unless otherwise indicated, dimensions are the same as Grommet (G).

# Series VF1000/3000/5000

## Series VF1000/Dimensions

### Type 31/VV5F1-31-□□3-□: Individual exhaust Grommet (G) (H)

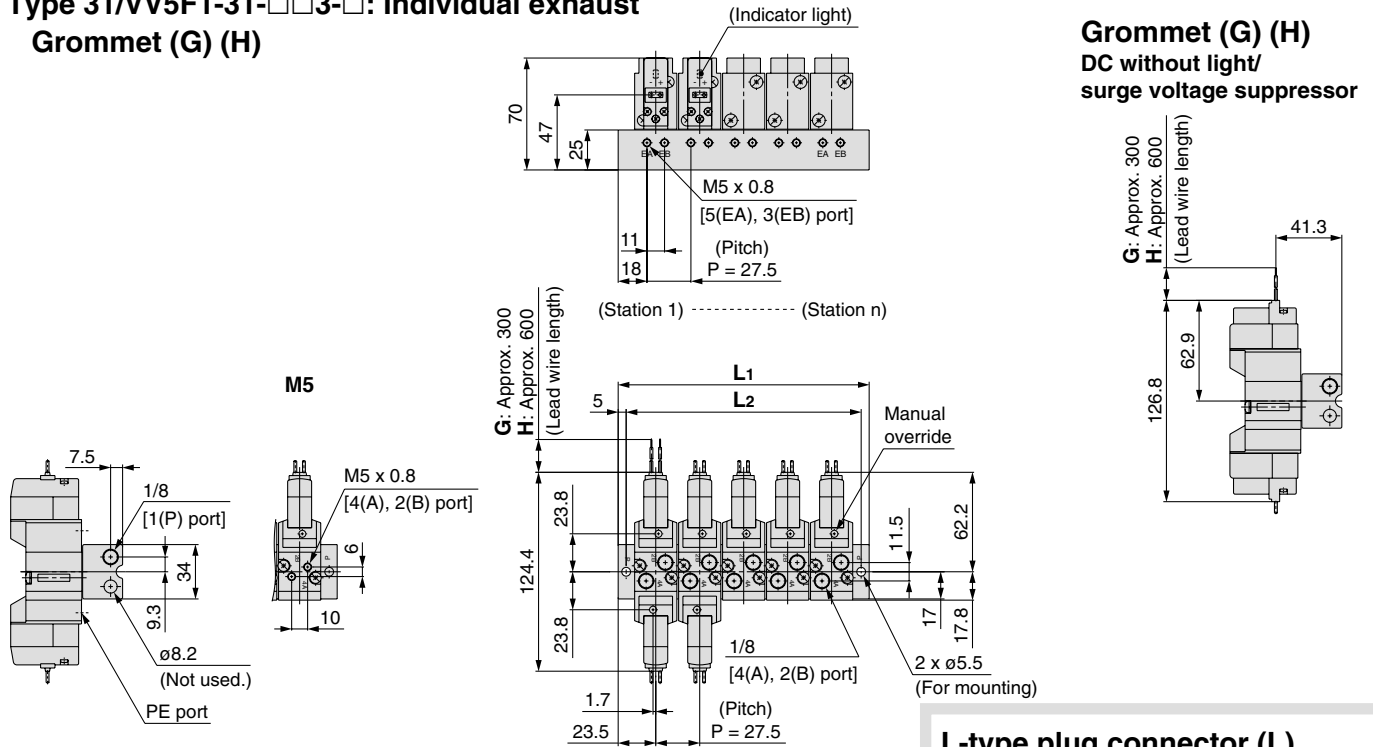

#### L: Dimensions

n	2	3	4	5	6	7	8	9	10	11	12	13	14
L1	74.5	102	129.5	157	184.5	212	239.5	267	294.5	322	349.5	377	404.5
L2	64.5	92	119.5	147	174.5	202	229.5	257	284.5	312	339.5	367	394.5

n	15	16	17	18	19	20
L1	432	459.5	487	514.5	542	569.5
L2	422	449.5	477	504.5	532	559.5

#### L-type plug connector (L)

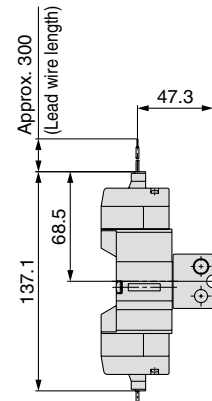

Unless otherwise indicated, dimensions are the same as Grommet (G).

#### M-type plug connector (M)

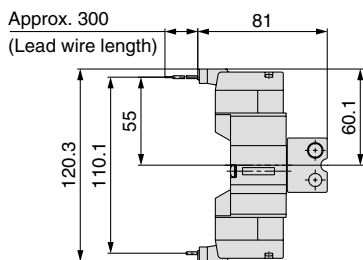

#### DIN terminal (D) (Y)

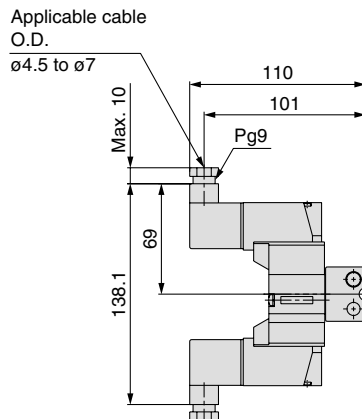

Unless otherwise indicated, dimensions are the same as Grommet (G).

#### Conduit terminal (T)

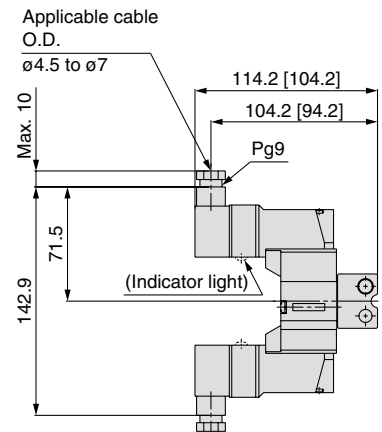

[ ]: Without indicator light  
Unless otherwise indicated, dimensions are the same as Grommet (G).

Unless otherwise indicated, dimensions are the same as Grommet (G).

# Pilot Operated 5 Port Solenoid Valve Body Ported/Manifold *Series VF1000/3000/5000*

## Series VF3000/Dimensions

### Type 30/VV5F3-30-□□1-□: Common exhaust Grommet (G) (H)

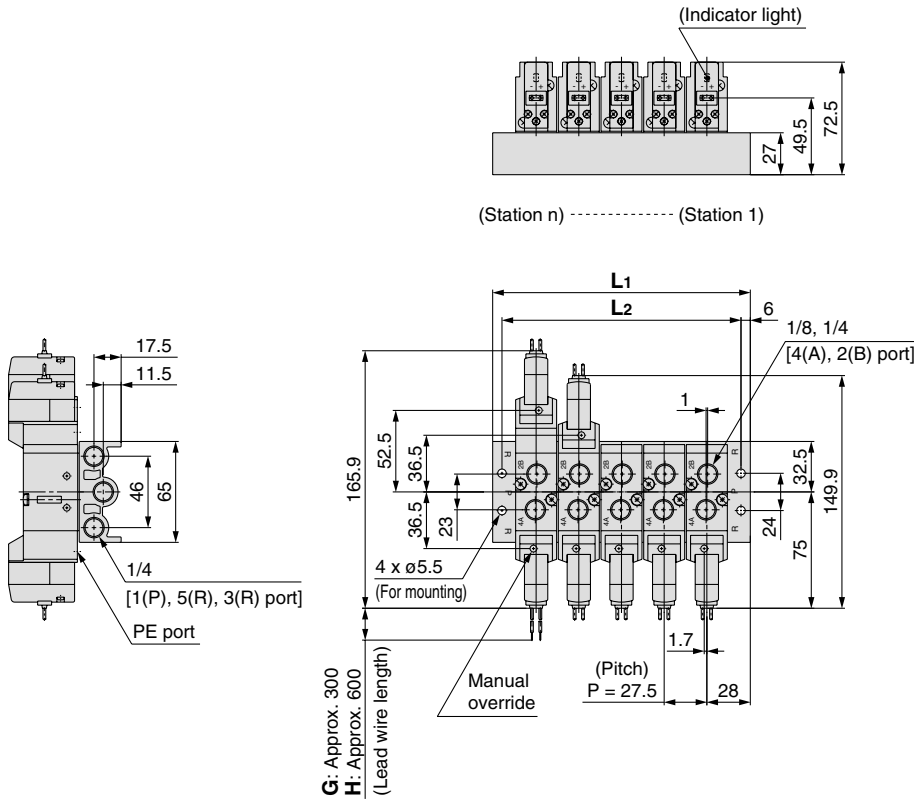

### Grommet (G) (H) DC without light/ surge voltage suppressor

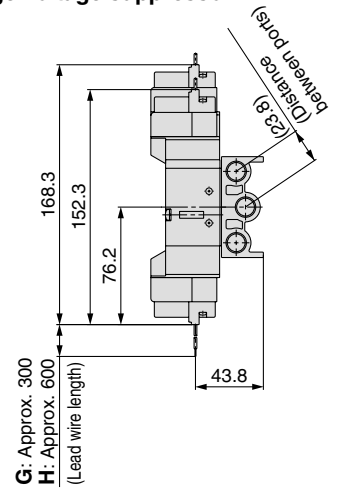

### L-type plug connector (L)

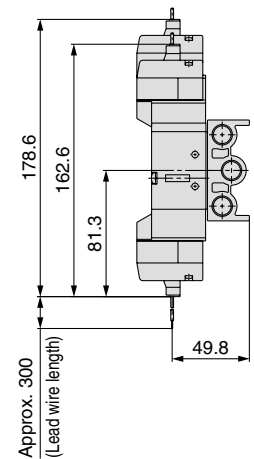

Unless otherwise indicated, dimensions are the same as Grommet (G).

### L: Dimensions

L	n	2	3	4	5	6	7	8	9	10	11	12	13	14
L1	n	83.5	111	138.5	166	193.5	221	248.5	276	303.5	331	358.5	386	413.5
L2	n	71.5	99	126.5	154	181.5	209	236.5	264	291.5	319	346.5	374	401.5

L	n	15	16	17	18	19	20
L1	n	441	468.5	496	523.5	551	578.5
L2	n	429	456.5	484	511.5	539	566.5

### M-type plug connector (M)

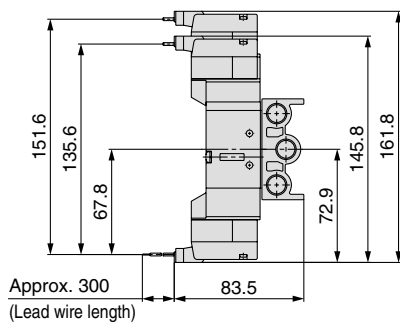

Unless otherwise indicated, dimensions are the same as Grommet (G).

### DIN terminal (D) (Y)

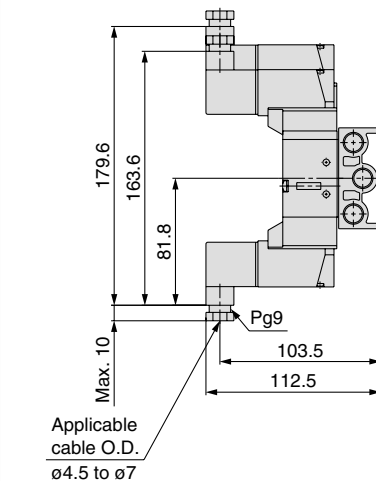

Unless otherwise indicated, dimensions are the same as Grommet (G).

### Conduit terminal (T)

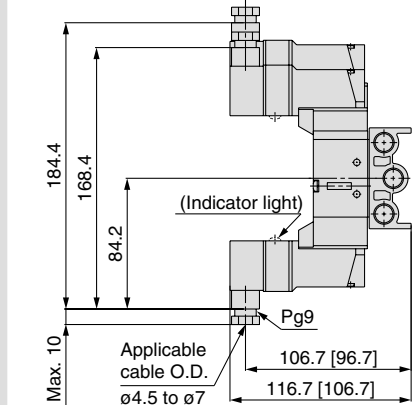

[ ]: Without indicator light  
Unless otherwise indicated, dimensions are the same as Grommet (G).

# Series VF1000/3000/5000

## Series VF3000/Dimensions

Type 30/VV5F3-30-□□1-□: When the individual EXH spacer (VF3000-75-1A) is mounted.  
Grommet (G) (H)

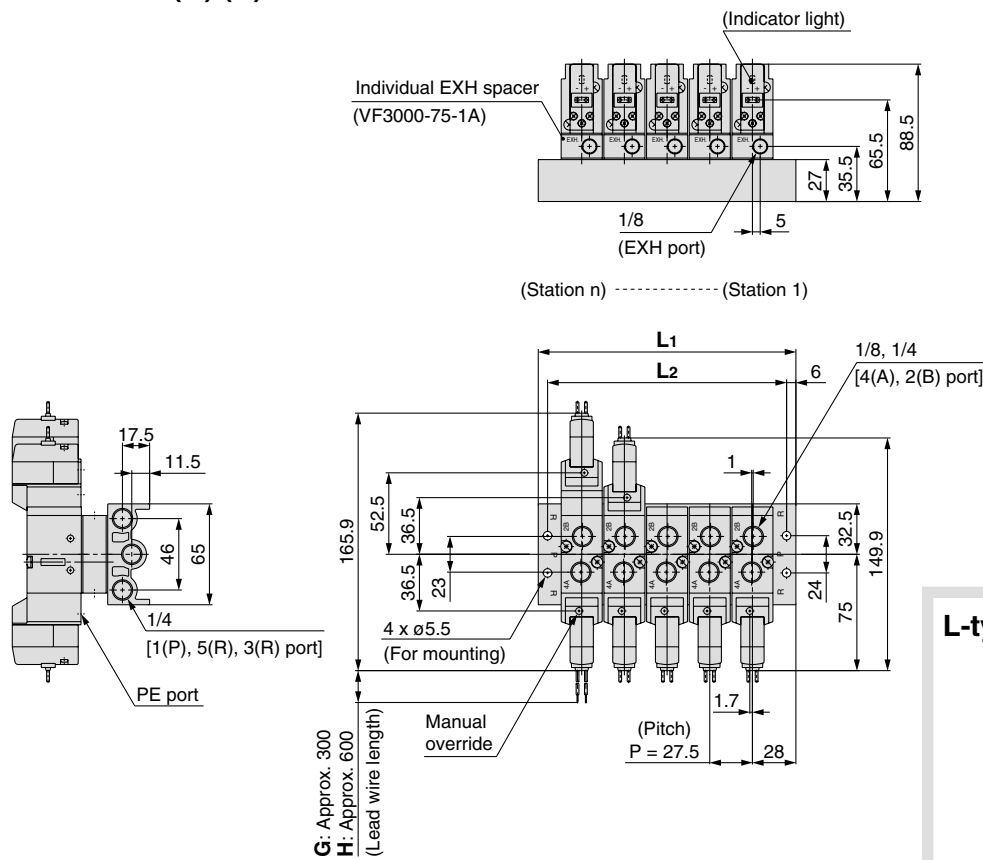

**Grommet (G) (H)**  
DC without light/  
surge voltage suppressor

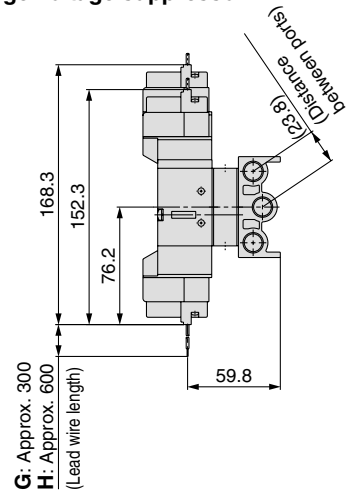

**L-type plug connector (L)**

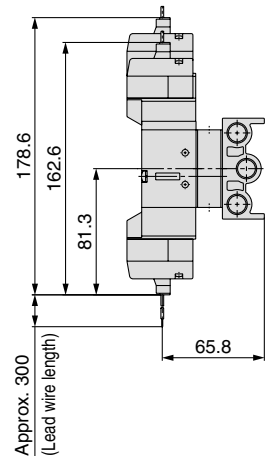

Unless otherwise indicated, dimensions are the same as Grommet (G).

### L: Dimensions

n	2	3	4	5	6	7	8	9	10	11	12	13	14
L1	83.5	111	138.5	166	193.5	221	248.5	276	303.5	331	358.5	386	413.5
L2	71.5	99	126.5	154	181.5	209	236.5	264	291.5	319	346.5	374	401.5

n	15	16	17	18	19	20
L1	441	468.5	496	523.5	551	578.5
L2	429	456.5	484	511.5	539	566.5

### M-type plug connector (M)

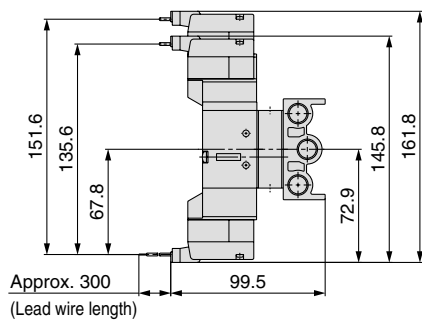

Approx. 300  
(Lead wire length)

### DIN terminal (D) (Y)

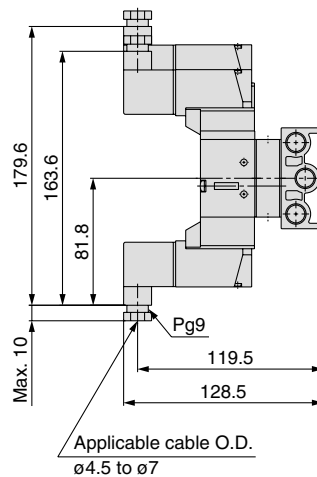

Unless otherwise indicated, dimensions are the same as Grommet (G).

### Conduit terminal (T)

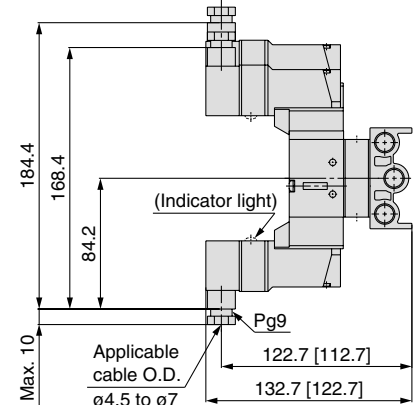

Unless otherwise indicated, dimensions are the same as Grommet (G).

Unless otherwise indicated, dimensions are the same as Grommet (G).

# Pilot Operated 5 Port Solenoid Valve Body Ported/Manifold *Series VF1000/3000/5000*

## Series VF5000/Dimensions

### Type 20/VV5F5-20-□□1-□: Common exhaust Grommet (G)

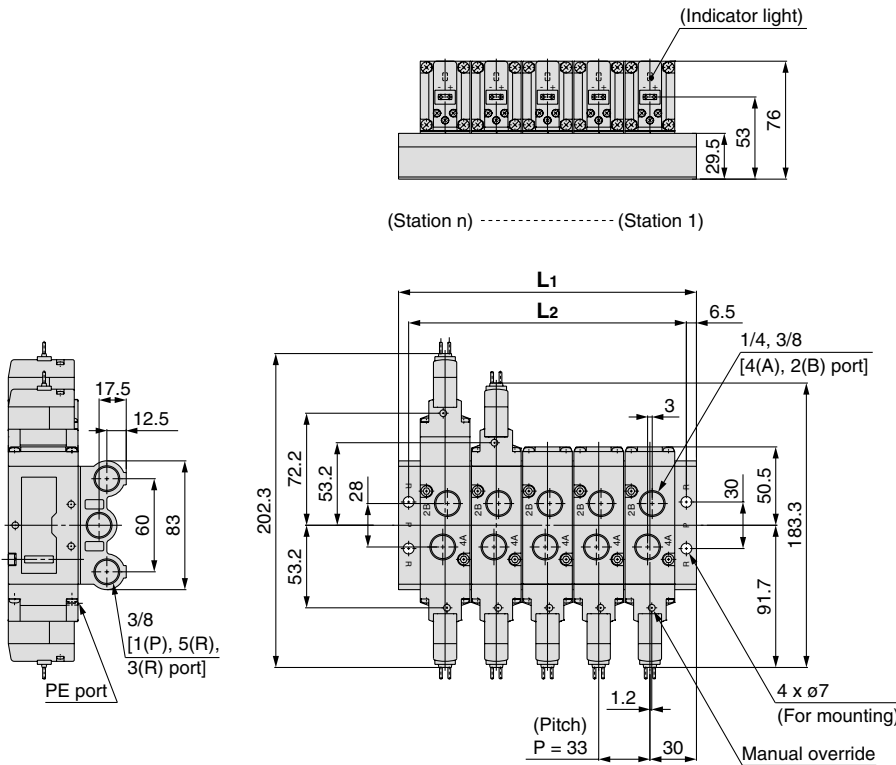

### Grommet (G) (H) DC without light/ surge voltage suppressor

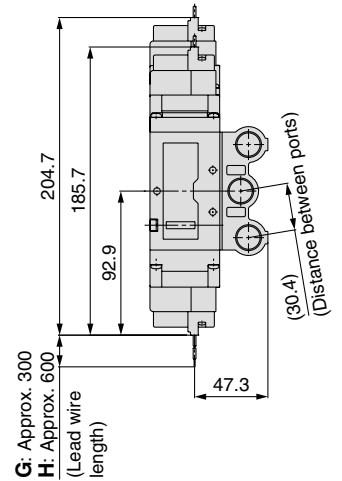

### L-type plug connector (L)

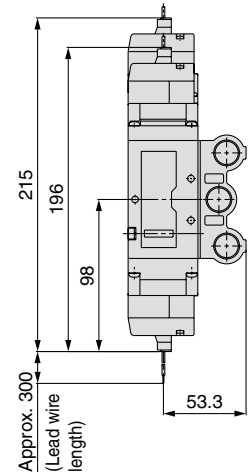

Unless otherwise indicated, dimensions are the same as Grommet (G).

### L: Dimensions

n	2	3	4	5	6	7	8	9	10
L1	93	126	159	192	225	258	291	324	357
L2	80	113	146	179	212	245	278	311	344

n: Stations

### M-type plug connector (M)

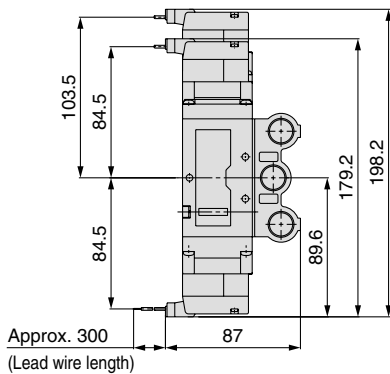

Unless otherwise indicated, dimensions are the same as Grommet (G).

### DIN terminal (D) (Y)

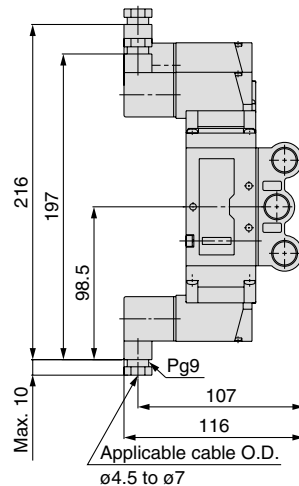

Unless otherwise indicated, dimensions are the same as Grommet (G).

### Conduit terminal (T)

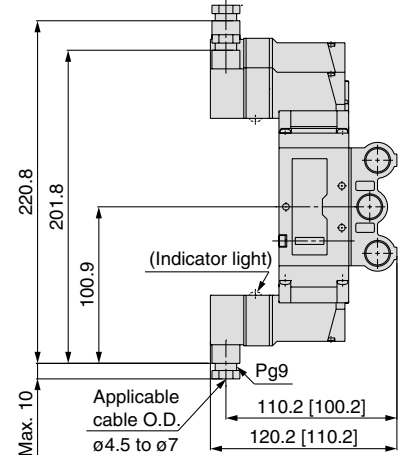

[ ]: Without indicator light  
Unless otherwise indicated, dimensions are the same as Grommet (G).

# Series VF1000/3000/5000

## Series VF5000/Dimensions

Type 20/VV5F5-20-□□1-□: When the individual EXH spacer (VF5000-75-1A) is mounted.  
Grommet (G)

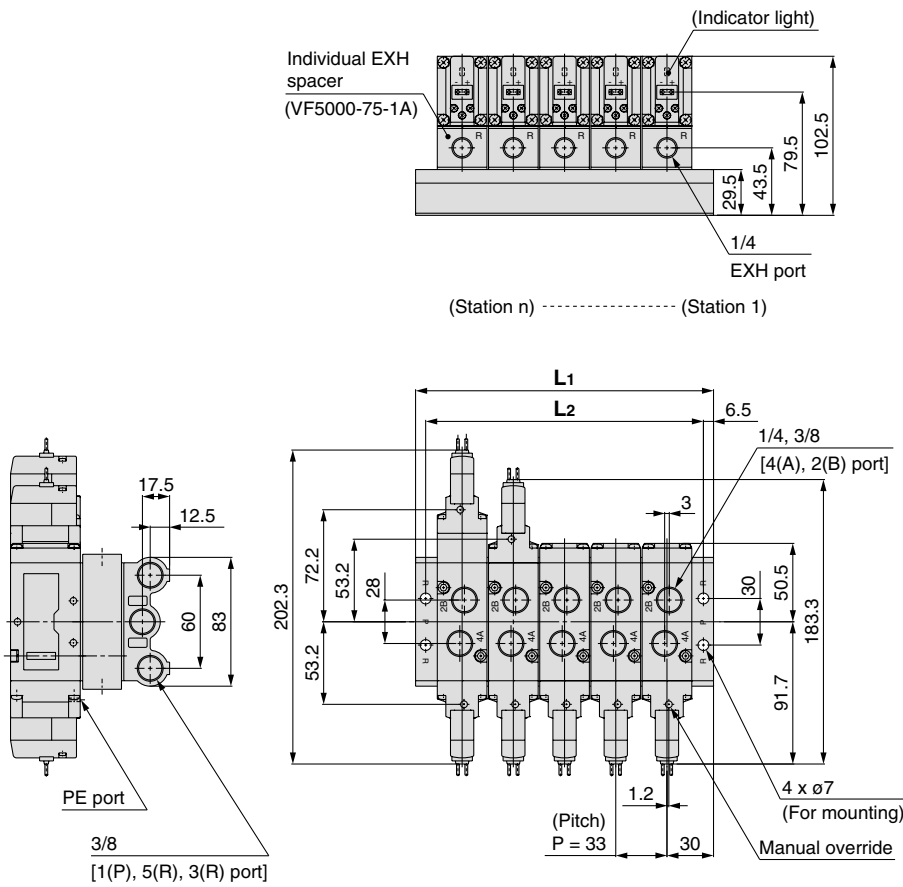

### Grommet (G) (H) DC without light/ surge voltage suppressor

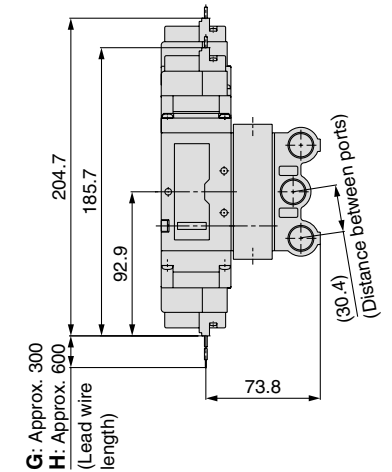

### L-type plug connector (L)

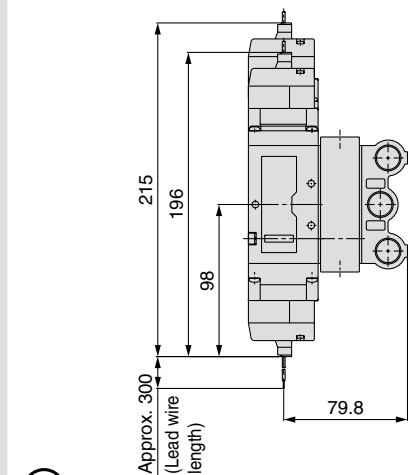

Unless otherwise indicated, dimensions are the same as Grommet (G).

### L: Dimensions

n	2	3	4	5	6	7	8	9	10
L1	93	126	159	192	225	258	291	324	357
L2	80	113	146	179	212	245	278	311	344

n: Stations

### M-type plug connector (M)

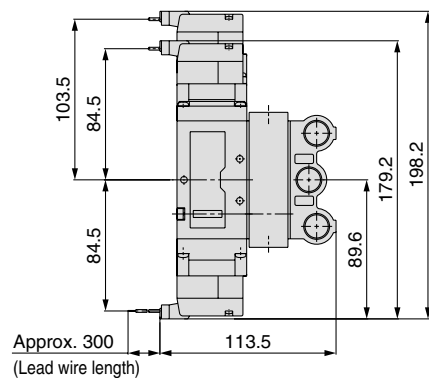

Unless otherwise indicated, dimensions are the same as Grommet (G).

### DIN terminal (D) (Y)

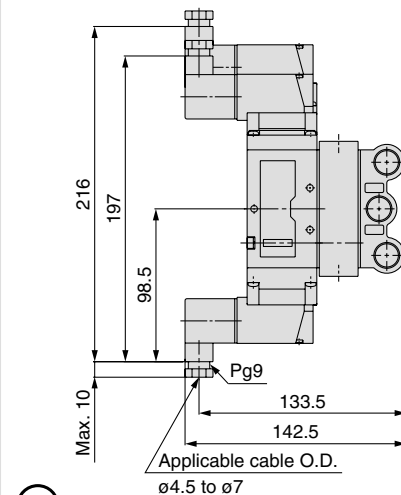

Unless otherwise indicated, dimensions are the same as Grommet (G).

### Conduit terminal (T)

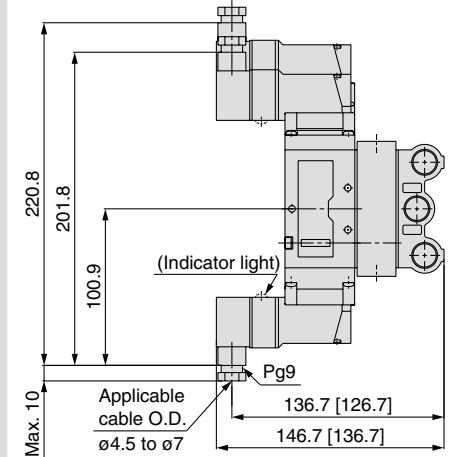

[ ]: Without indicator light  
Unless otherwise indicated, dimensions are the same as Grommet (G).



# Pilot Operated 5 Port Solenoid Valve Body Ported/Manifold *Series VF1000/3000/5000*

## Series VF5000/Dimensions

### Type 21/VV5F5-21-□□1-□: Common exhaust Grommet (G)

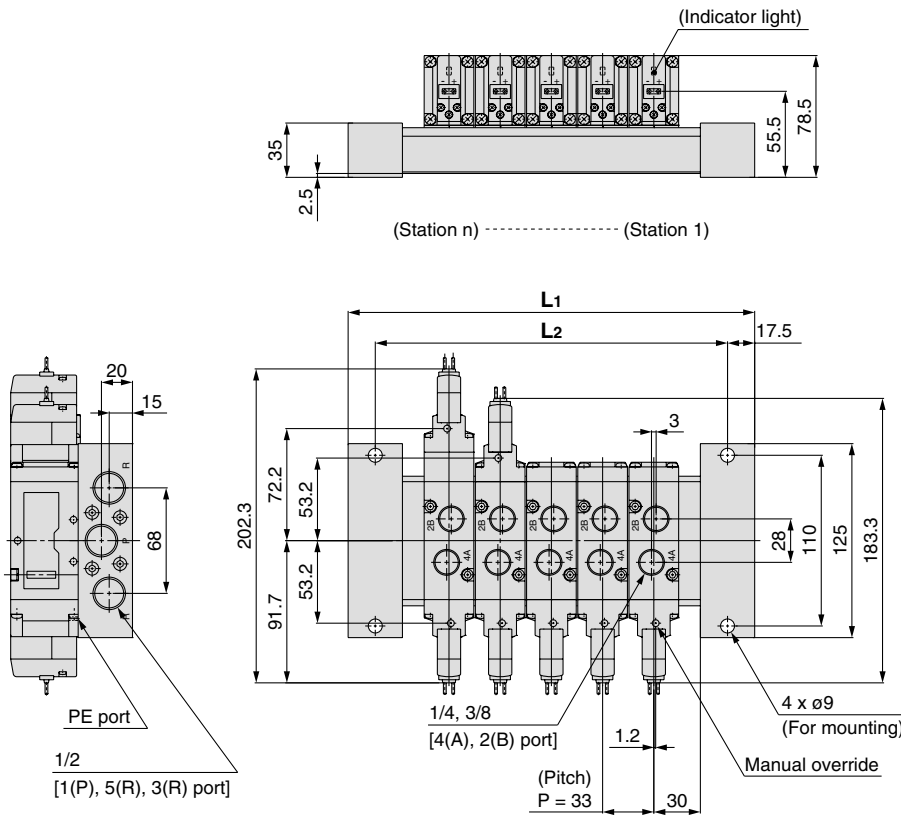

### Grommet (G) (H) DC without light/ surge voltage suppressor

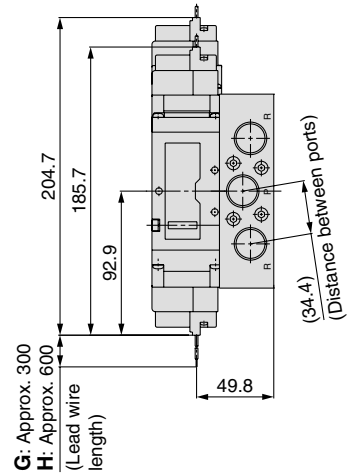

### L-type plug connector (L)

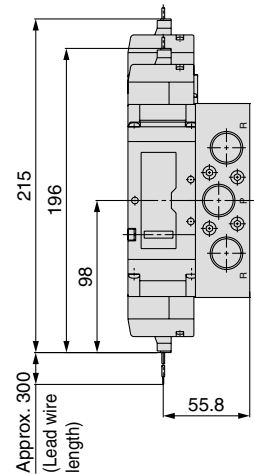

### L: Dimensions

n	2	3	4	5	6	7	8	9	10	11	12	13	14	15
L1	163	196	229	262	295	328	361	394	427	460	493	526	559	592
L2	128	161	194	227	260	293	326	359	392	425	458	491	524	557

n: Stations

Unless otherwise indicated, dimensions are the same as Grommet (G).

### M-type plug connector (M)

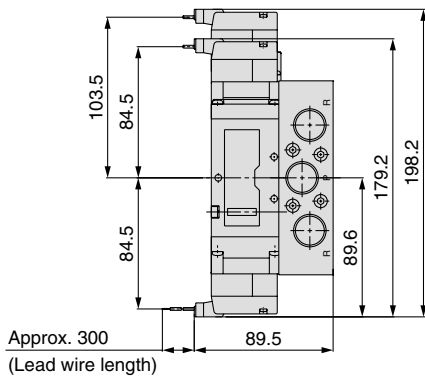

Unless otherwise indicated, dimensions are the same as Grommet (G).

### DIN terminal (D) (Y)

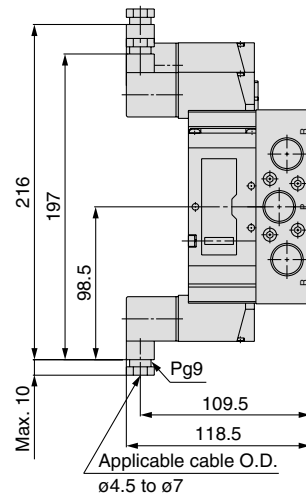

Unless otherwise indicated, dimensions are the same as Grommet (G).

### Conduit terminal (T)

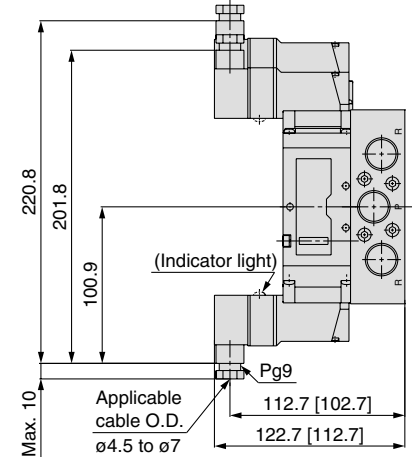

[ ]: Without indicator light  
Unless otherwise indicated, dimensions are the same as Grommet (G).

# Series VF1000/3000/5000

## Series VF5000/Dimensions

Type 21/VV5F5-21-□□1-□: When the individual EXH spacer (VF5000-75-1A) is mounted.  
Grommet (G)

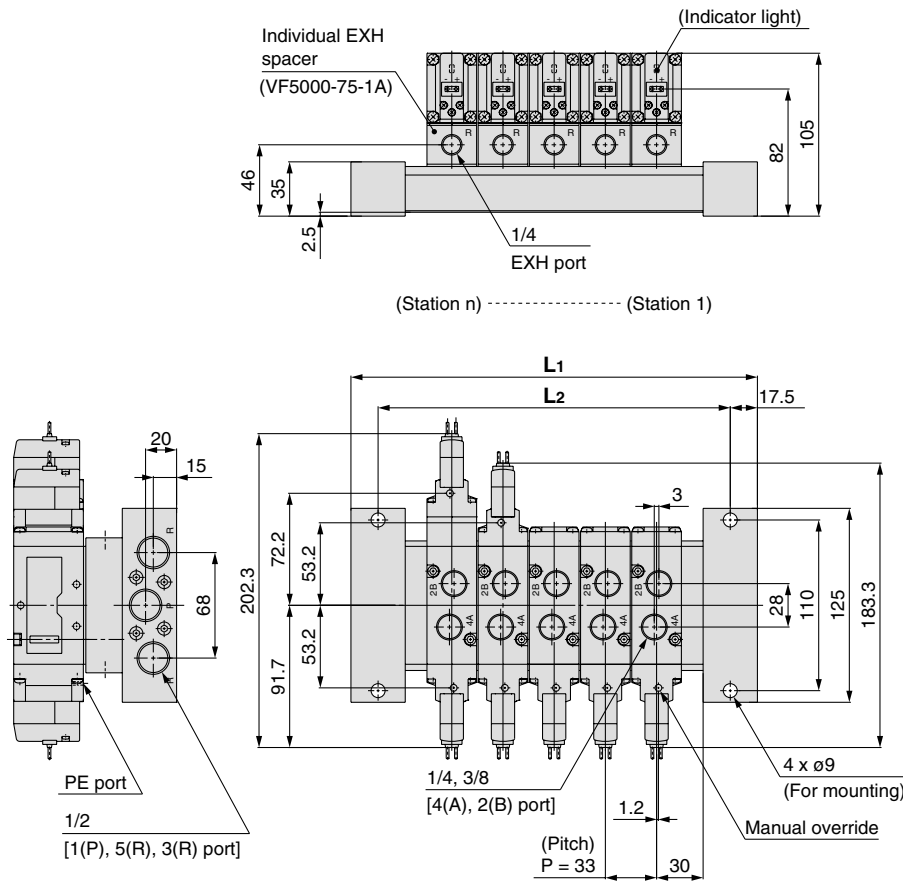

### Grommet (G) (H) DC without light/ surge voltage suppressor

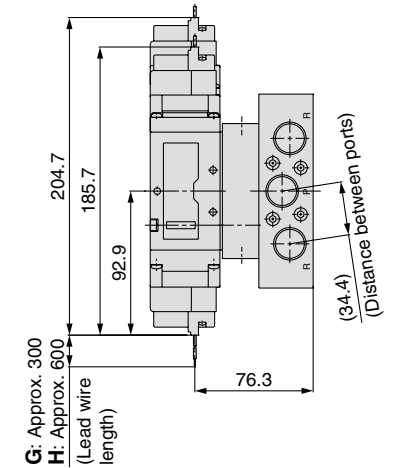

### L-type plug connector (L)

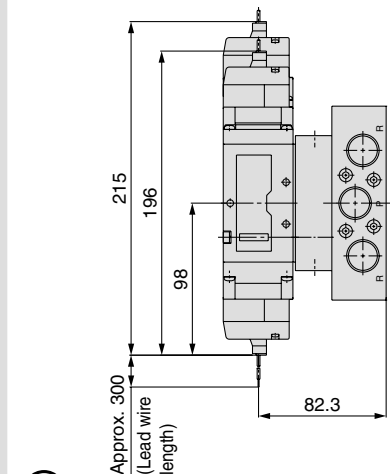

Unless otherwise indicated, dimensions are the same as Grommet (G).

### L: Dimensions

n	2	3	4	5	6	7	8	9	10	11	12	13	14	15
L1	163	196	229	262	295	328	361	394	427	460	493	526	559	592
L2	128	161	194	227	260	293	326	359	392	425	458	491	524	557

n: Stations

### M-type plug connector (M)

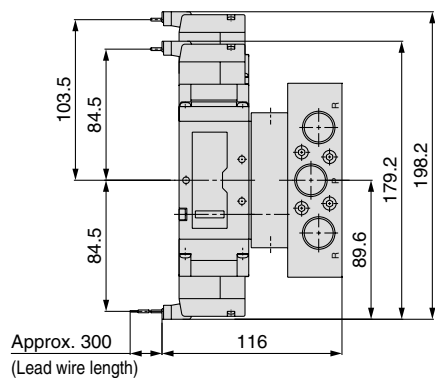

### DIN terminal (D) (Y)

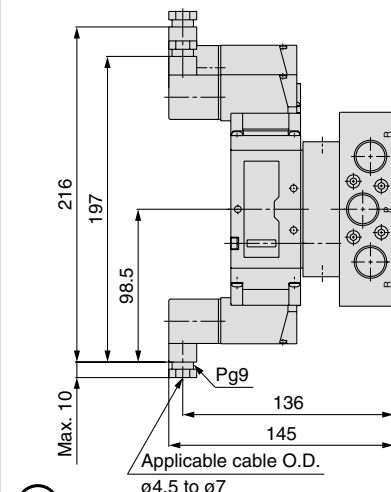

Unless otherwise indicated, dimensions are the same as Grommet (G).

### Conduit terminal (T)

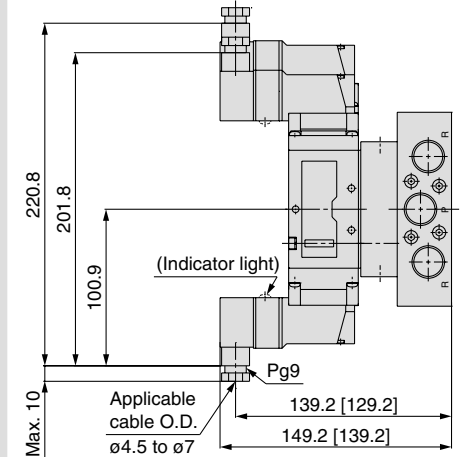

Unless otherwise indicated, dimensions are the same as Grommet (G).

Unless otherwise indicated, dimensions are the same as Grommet (G).



# Pilot Operated 5 Port Solenoid Valve Series VF3000/5000 Manifold

Base Mounted

## How to Order Manifold



Note) Only DIN and conduit terminal types are available with AC mode. Refer to the electrical entry for details.

### Common exhaust

Series **3** - 40 - 05 2 - 02 **F**

Symbol	Series	P, R port size	A, B port size
3	VF3000	1/4	1/4
5	VF5000	3/8	1/4

Note) The A and B ports are made on the bottom.

Stations	
02	2 stations
⋮	⋮
20	20 stations

Note) Up to 10 stations for VV5F5.

Thread type	
—	Rc
F	G
N	NPT
T	NPTF

## How to Order Valve (With a gasket and two mounting screws)

Series **3** **1** **4** **0** **—** **—** - **5** **G** **—** **—** **1**

Series	
3	VF3000
5	VF5000

Note) Not available with the VF1000.

Type of actuation	
1	2-position single
2	2-position double
3	3-position closed centre
4	3-position exhaust centre
5	3-position pressure centre

### Body model

Body option	VF3000	VF5000
0: Pilot valve individual exhaust		
3: Main/Pilot valve common exhaust		
4: Pilot valve base exhaust		

Pressure specification	
—	Standard (0.7 MPa)
K	High-pressure type (1 MPa)

### Rated voltage

DC	AC (50/60 Hz)
5	1
6	2
	3
	4
	7
	8

Note) Only DIN and conduit terminal types can be set for AC mode. Refer to electrical entry for details.

Coil specification	
—	Standard
T	With power saving circuit (DC only)

Note 1) Be sure to select the power saving circuit type when it is continuously energized for long periods of time. (Refer to back pages 6 and 7 for details.)

Note 2) T type is available with DC mode only. When T is selected, only Z type of light/surge voltage suppressor is available. (Note that when the electrical entry of DIN terminal type without connector is selected, only DOS and YOS are available.)

### Manual override

—: Non-locking push type	D: Push-turn locking slotted type	E: Push-turn locking lever type

### Light/surge voltage suppressor

Symbol	Light/surge voltage suppressor	DC	AC
—	Without light/surge voltage suppressor	○	○
S	With surge voltage suppressor	○	○ <sup>Note 1)</sup>
Z	With light/surge voltage suppressor	○	○
R	With surge voltage suppressor (Non-polar)	○	—
U	With light/surge voltage suppressor (Non-polar)	○	—

Note 1) There is no S option for AC mode, since a rectifier prevents surge voltage generation.

Note 2) In the DIN terminal type, since a light is installed in the connector, DOZ, DOU, YOZ, YOU options are not available.

## Caution

When using the surge voltage suppressor type, residual voltage will remain. Refer to back page 7 for details.

### Electrical entry

	Grommet	L-type plug connector	M-type plug connector	DIN terminal	DIN (EN175301-803) terminal	Conduit terminal
	<b>G:</b> Lead wire length 300 mm <b>H:</b> Lead wire length 600 mm	<b>L:</b> With lead wire (length 300 mm) <b>LN:</b> Without lead wire <b>LO:</b> Without connector	<b>M:</b> With lead wire (length 300 mm) <b>MN:</b> Without lead wire <b>MO:</b> Without connector	<b>D:</b> With connector <b>DO:</b> Without connector	<b>Y:</b> With connector <b>YO:</b> Without connector	<b>T:</b> Conduit terminal
DC	○	○	○	○	○	○
AC	—	—	—	○	○	○

Note 1) LN and MN types are with 2 sockets.

Note 2) Refer to back page 4 when different length of lead wire for L/M-type plug connector is required.

Note 3) Refer to back page 5 for details on the DIN (EN175301-803) terminal.

Note 4) When using with IP65, select the main/pilot valve common exhaust or pilot valve base exhaust type.

# Pilot Operated 5 Port Solenoid Valve Base Mounted/Manifold *Series VF3000/5000*

## Manifold Specifications

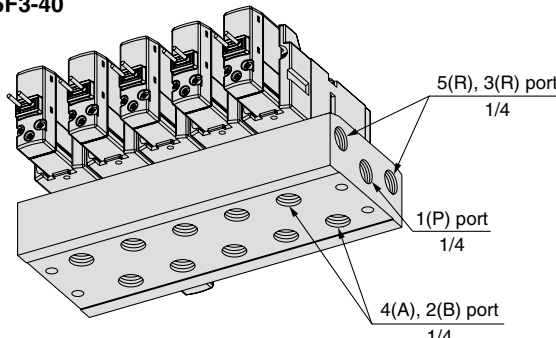
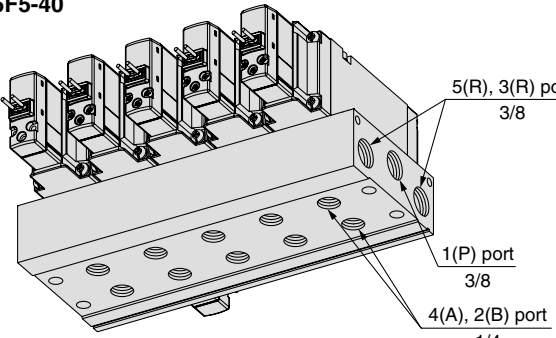
Series	Manifold base model	EXH port type	Applicable valve model	Applicable stations	Manifold base Weight: W [g] Stations: n
VF3000		Common EXH	<b>VF3□40</b> <b>VF3□43</b>	2 to 20 stations	W= 110n + 116
VF5000		Common EXH	<b>VF5□44</b>	2 to 10 stations	W= 161n + 128

Note) Supply pressure to 1(P) ports and exhaust pressure from R ports on both sides for 10 stations or more (5 stations or more for the VF5000).

## How to Order Manifold Assembly

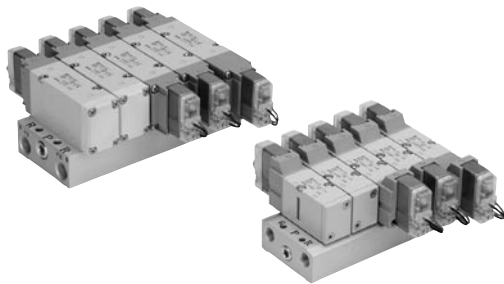

### Example (VV5F3-40)

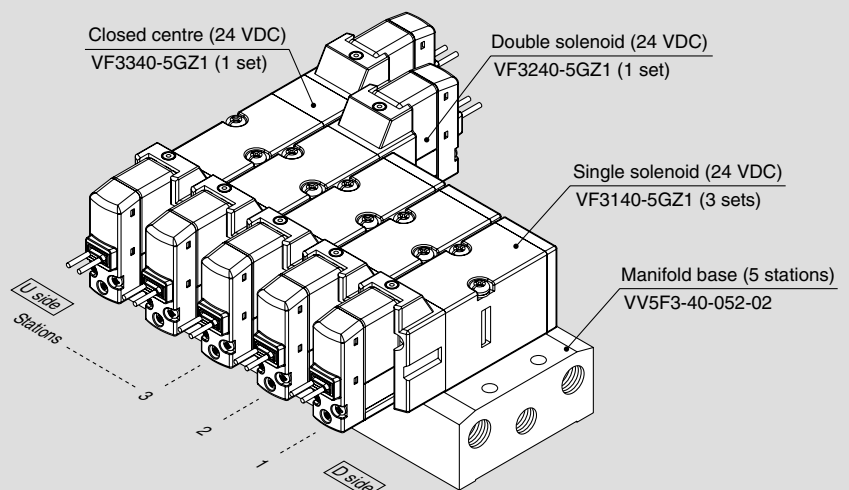

- |                       |   |
|-----------------------|---|
| VV5F3-40-052-02 ..... | 1 set (Type 40, 5-station manifold base part no.) |
| * VF3140-5GZ1 .....   | 3 sets (Single solenoid part no.)                 |
| * VF3240-5GZ1 .....   | 1 set (Double solenoid part no.)                  |
| * VF3340-5GZ1 .....   | 1 set (Closed centre part no.)                    |

↳ The asterisk denotes the symbol for assembly. Prefix it to the part nos. of the solenoid valve, etc.

- The valve arrangement is numbered as the 1st station from D side.
- Indicate the valves to be attached below the manifold base part number, in order starting from station 1 as shown in the drawing. If the arrangement becomes complicated, then indicate on the manifold specification sheet.

# Series VF3000/5000

## Manifold Options

### ■ For base mounted Blanking plate assembly

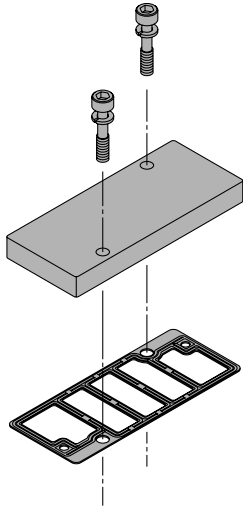

Series	Blanking plate assembly part no.
<b>VF3000</b>	DXT031-38-5A
<b>VF5000</b>	VF5000-70-2A

### ■ Mounting screw, gasket part no.

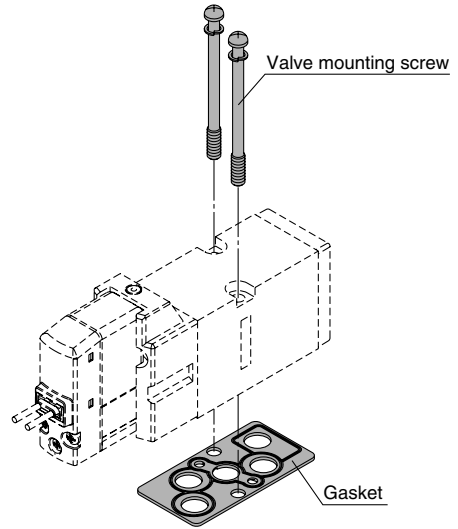

Series	Valve mounting screw (1 pc.)	Gasket
<b>VF3000</b>	Round head combination screw DXT031-44-1 (With M4 x 39.5 SW)	DXT031-30-11
<b>VF5000</b>	Hexagon socket head cap screw AXT620-32-1 (With M4 x 48 SW)	DXT156-9-8

### ■ Individual EXH spacer assembly

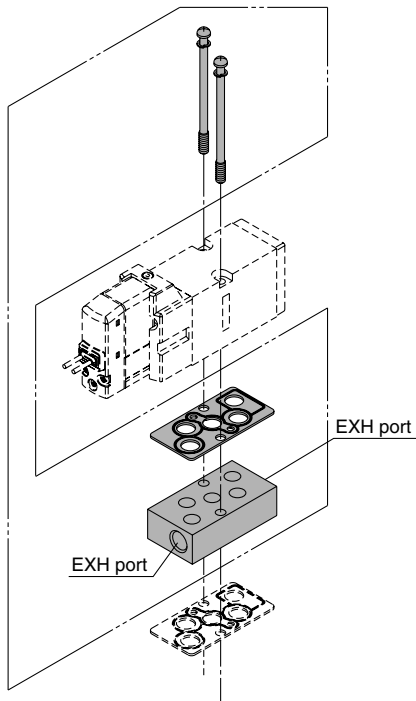

### ⚠ Caution

**Tightening Torque of Mounting Screw**

**M4: 1.4 N·m**

### ⚠ Warning

When mounting a valve or spacer on the manifold base or sub-plate, etc., the mounting orientation is already decided. If mounted in a wrong direction, the equipment to be connected may result in malfunction. Refer to external dimensions in mounting.

**VF 3 000-75-2 A**

#### • Series

Symbol	Series	Port size
<b>3</b>	VF3000	1/8
<b>5</b>	VF5000	1/4

#### • Thread type

—	Rc
<b>F</b>	G
<b>N</b>	NPT
<b>T</b>	NPTF

**Series VF3000/Dimensions**

**Type 40/VV5F3-40-□□2-02□: Common exhaust  
Grommet (G) (H)**

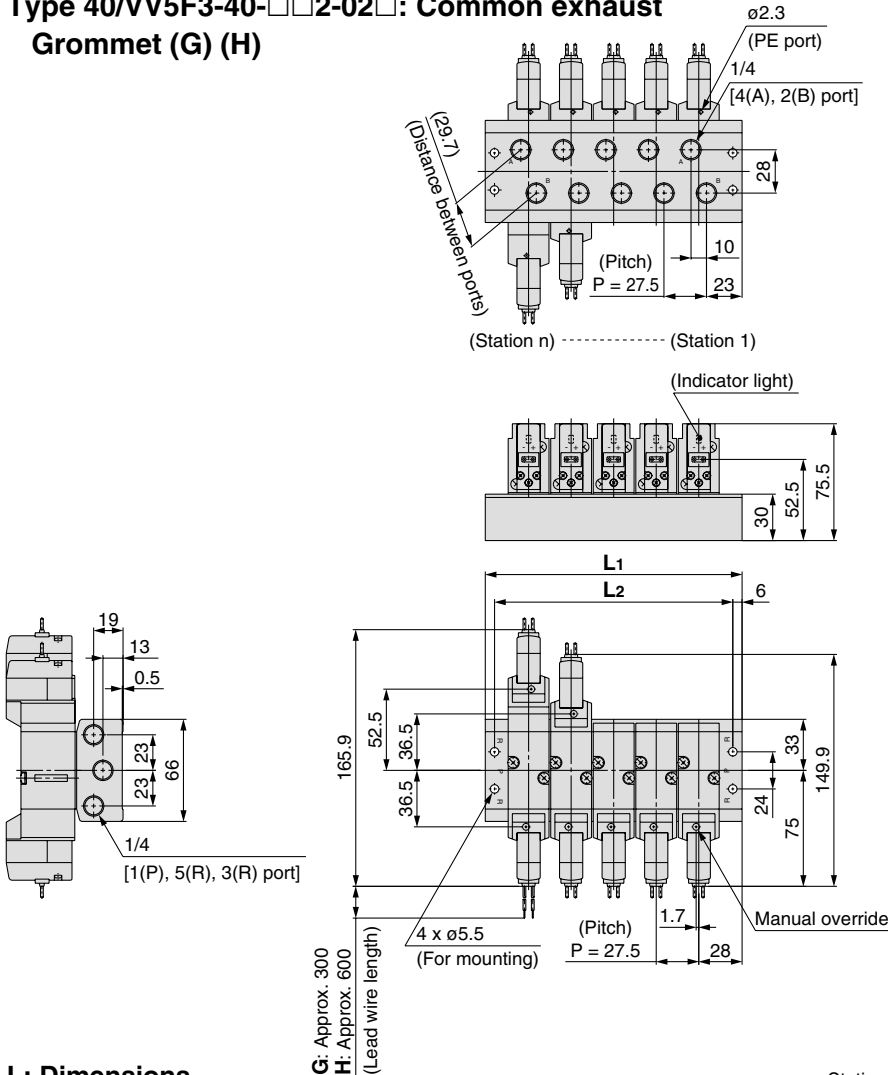

**L: Dimensions**

L \ n	2	3	4	5	6	7	8	9	10	11	12	13	14
L1	83.5	111	138.5	166	193.5	221	248.5	276	303.5	331	358.5	386	413.5
L2	71.5	99	126.5	154	181.5	209	236.5	264	291.5	319	346.5	374	401.5

L \ n	15	16	17	18	19	20
L1	441	468.5	496	523.5	551	578.5
L2	429	456.5	484	511.5	539	566.5

**Grommet (G) (H)  
DC without light/  
surge voltage suppressor**

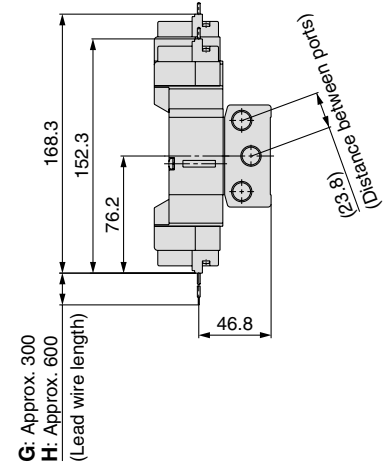

**L-type plug connector (L)**

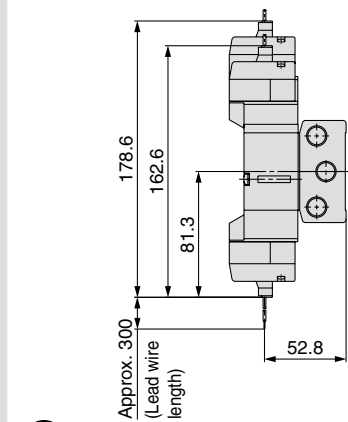

Unless otherwise indicated, dimensions are the same as Grommet (G).

**M-type plug connector (M)**

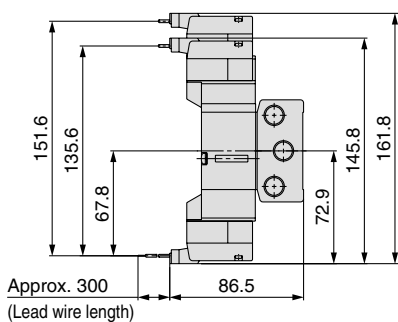

Unless otherwise indicated, dimensions are the same as Grommet (G).

**DIN terminal (D) (Y)**

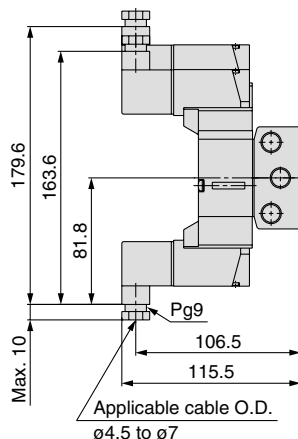

Unless otherwise indicated, dimensions are the same as Grommet (G).

**Conduit terminal (T)**

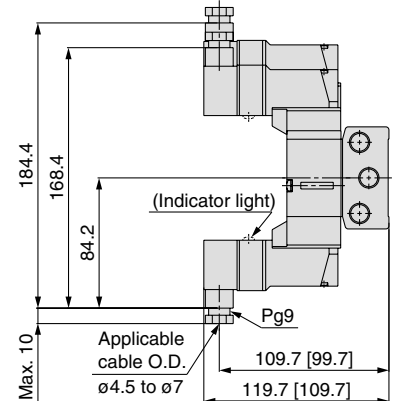

Unless otherwise indicated, dimensions are the same as Grommet (G).

# Series VF3000/5000

## Series VF3000/Dimensions

Type 40/VV5F3-40-□□2-02□: When the individual EXH spacer (VF3000-75-2A) is mounted.

Grommet (G) (H)

Grommet (G) (H)

DC without light/  
surge voltage suppressor

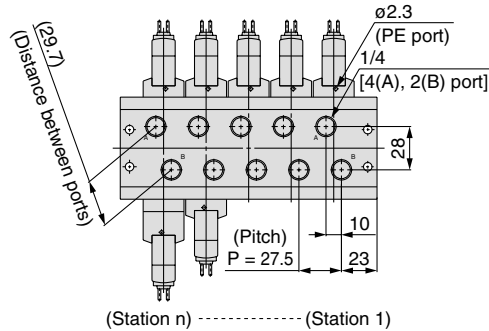

(Station n) ..... (Station 1)

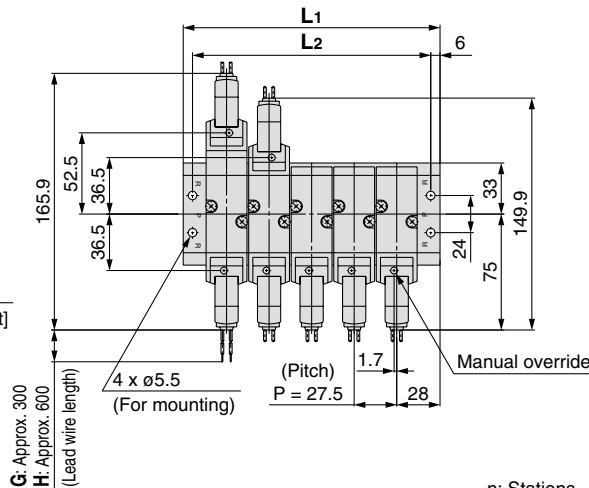
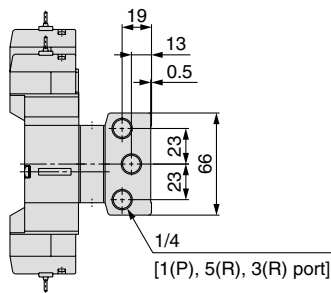
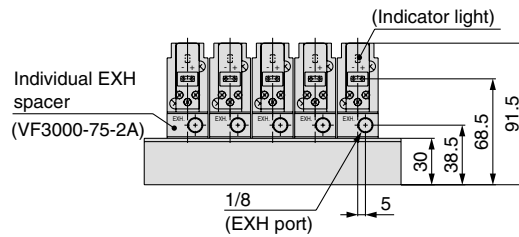

L: Dimensions

L \ n	2	3	4	5	6	7	8	9	10	11	12	13	14
L1	83.5	111	138.5	166	193.5	221	248.5	276	303.5	331	358.5	386	413.5
L2	71.5	99	126.5	154	181.5	209	236.5	264	291.5	319	346.5	374	401.5

L \ n	15	16	17	18	19	20
L1	441	468.5	496	523.5	551	578.5
L2	429	456.5	484	511.5	539	566.5

n: Stations

G: Approx. 300  
H: Approx. 600  
(Lead wire length)

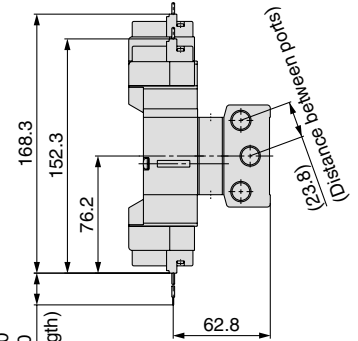

L-type plug connector (L)

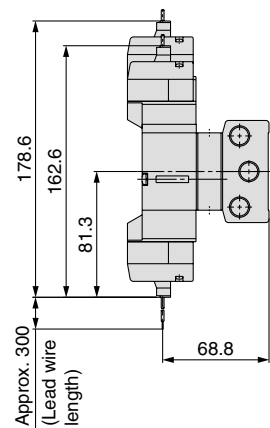

Unless otherwise indicated, dimensions are the same as Grommet (G).

M-type plug connector (M)

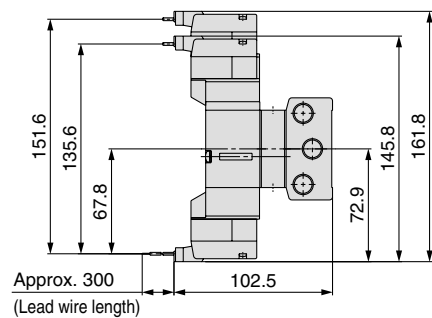

DIN terminal (D) (Y)

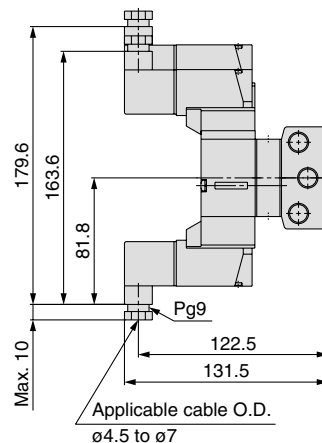

Unless otherwise indicated, dimensions are the same as Grommet (G).

Conduit terminal (T)

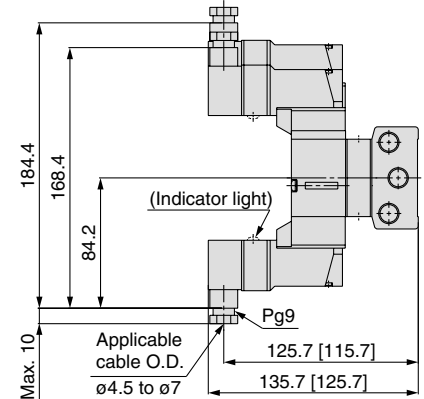

[ ]: Without indicator light  
Unless otherwise indicated, dimensions are the same as Grommet (G).

Unless otherwise indicated, dimensions are the same as Grommet (G).



**Series VF5000/Dimensions**

**Type 40/VV5F5-40-□□2-02□: Common exhaust  
Grommet (G)**

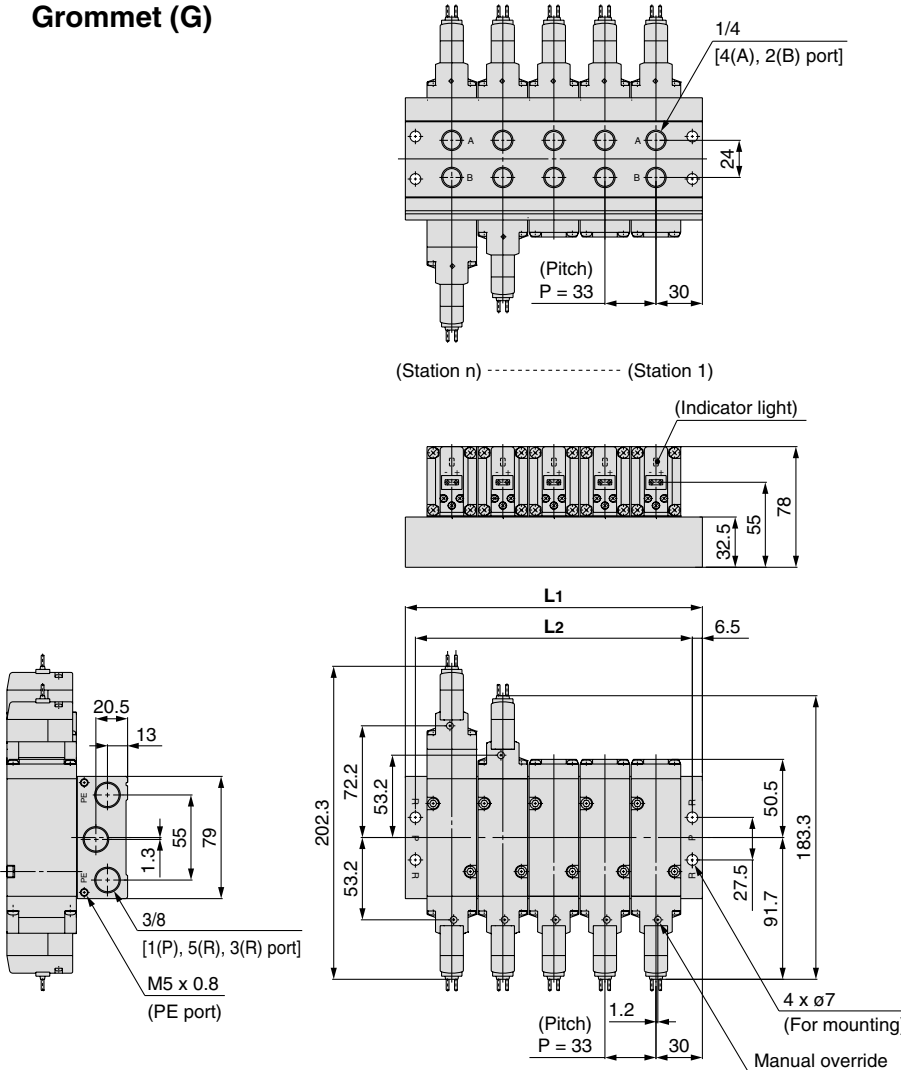

**Grommet (G) (H)  
DC without light/  
surge voltage suppressor**

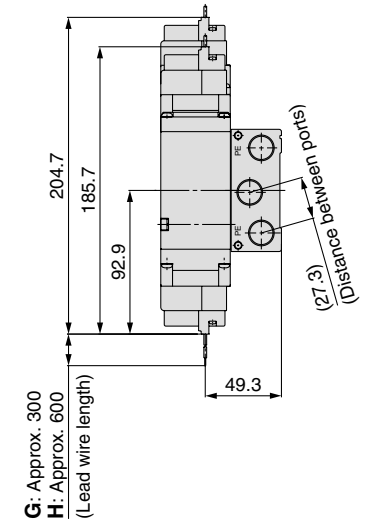

**L-type plug connector (L)**

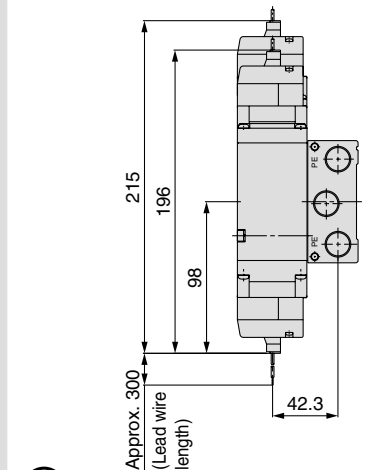

**L: Dimensions** n: Stations

n	2	3	4	5	6	7	8	9	10
L1	93	126	159	192	225	258	291	324	357
L2	80	113	146	179	212	245	278	311	344

Unless otherwise indicated, dimensions are the same as Grommet (G).

**M-type plug connector (M)**

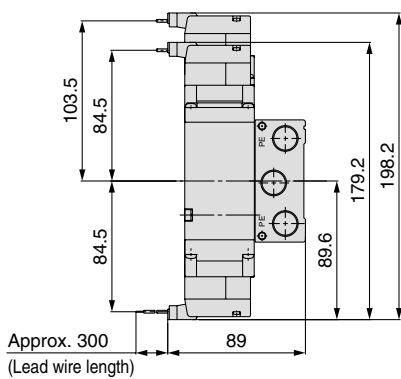

Unless otherwise indicated, dimensions are the same as Grommet (G).

**DIN terminal (D) (Y)**

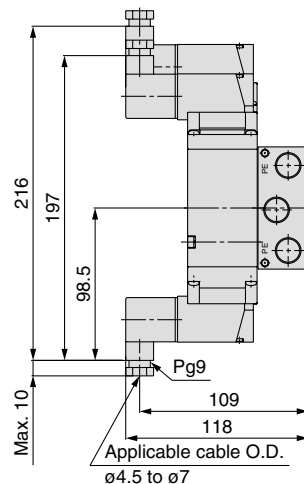

Unless otherwise indicated, dimensions are the same as Grommet (G).

**Conduit terminal (T)**

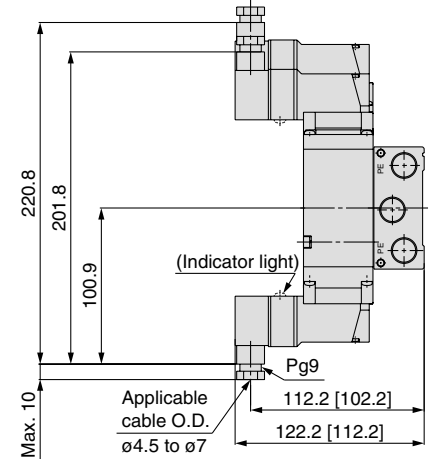

[ ]: Without indicator light  
Unless otherwise indicated, dimensions are the same as Grommet (G).

# Series VF3000/5000

## Series VF5000/Dimensions

Type 40/VV5F5-40-□□2-02□: When the individual EXH spacer (VF5000-75-2A) is mounted.

### Grommet (G)

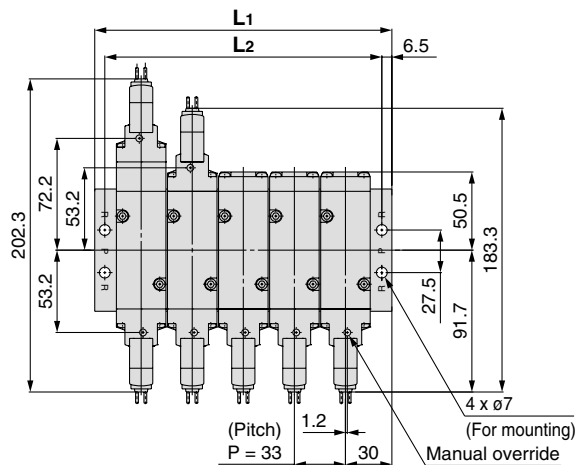
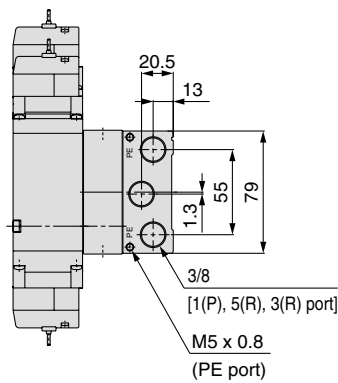
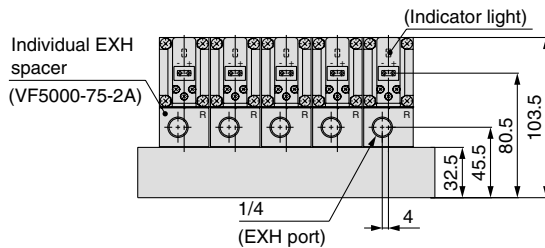
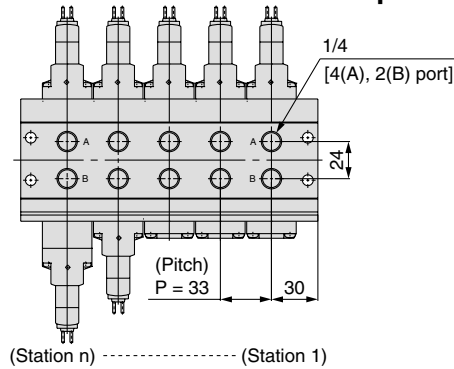

### L: Dimensions

n	2	3	4	5	6	7	8	9	10
L1	93	126	159	192	225	258	291	324	357
L2	80	113	146	179	212	245	278	311	344

### Grommet (G) (H) DC without light/ surge voltage suppressor

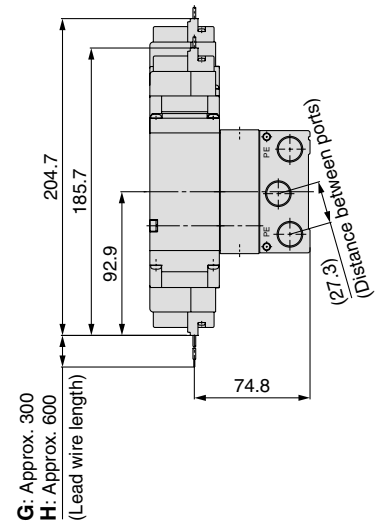

### L-type plug connector (L)

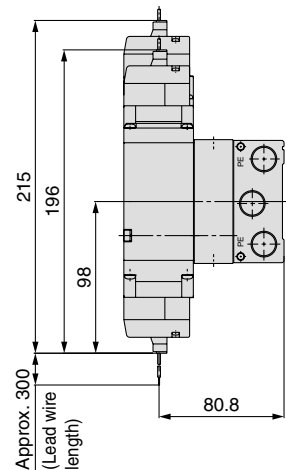

Unless otherwise indicated, dimensions are the same as Grommet (G).

### M-type plug connector (M)

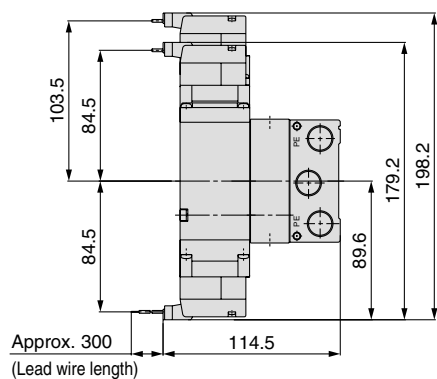

### DIN terminal (D) (Y)

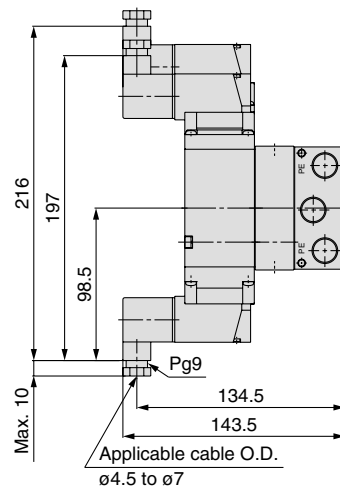

Unless otherwise indicated, dimensions are the same as Grommet (G).

### Conduit terminal (T)

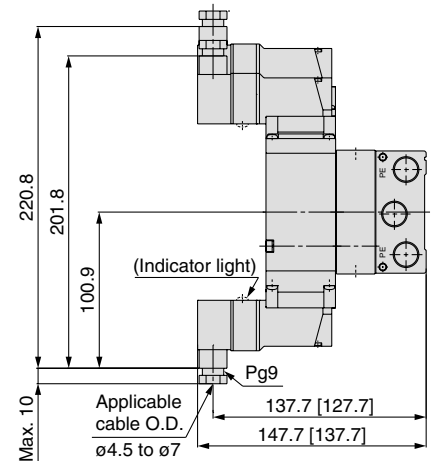

[ ]: Without indicator light  
Unless otherwise indicated, dimensions are the same as Grommet (G).

Unless otherwise indicated, dimensions are the same as Grommet (G).







# Safety Instructions

These safety instructions are intended to prevent hazardous situations and/or equipment damage. These instructions indicate the level of potential hazard with the labels of “**Caution,**” “**Warning**” or “**Danger.**” They are all important notes for safety and must be followed in addition to International Standards (ISO/IEC) <sup>Note 1)</sup> and other safety regulations.

Note 1) ISO 4414: Pneumatic fluid power – General rules relating to systems.  
ISO 4413: Hydraulic fluid power – General rules relating to systems.  
IEC 60204-1: Safety of machinery – Electrical equipment of machines. (Part 1: General requirements)  
ISO 10218: Manipulating industrial robots - Safety.  
etc.

-  **Caution:** **Caution** indicates a hazard with a low level of risk which, if not avoided, could result in minor or moderate injury.
-  **Warning:** **Warning** indicates a hazard with a medium level of risk which, if not avoided, could result in death or serious injury.
-  **Danger :** **Danger** indicates a hazard with a high level of risk which, if not avoided, will result in death or serious injury.

## Warning

### **1. The compatibility of the product is the responsibility of the person who designs the equipment or decides its specifications.**

Since the product specified here is used under various operating conditions, its compatibility with specific equipment must be decided by the person who designs the equipment or decides its specifications based on necessary analysis and test results. The expected performance and safety assurance of the equipment will be the responsibility of the person who has determined its compatibility with the product. This person should also continuously review all specifications of the product referring to its latest catalogue information, with a view to giving due consideration to any possibility of equipment failure when configuring the equipment.

### **2. Only personnel with appropriate training should operate machinery and equipment.**

The product specified here may become unsafe if handled incorrectly. The assembly, operation and maintenance of machines or equipment including our products must be performed by an operator who is appropriately trained and experienced.

### **3. Do not service or attempt to remove product and machinery/equipment until safety is confirmed.**

1. The inspection and maintenance of machinery/equipment should only be performed after measures to prevent falling or runaway of the driven objects have been confirmed.

2. When the product is to be removed, confirm that the safety measures as mentioned above are implemented and the power from any appropriate source is cut, and read and understand the specific product precautions of all relevant products carefully.

3. Before machinery/equipment is restarted, take measures to prevent unexpected operation and malfunction.

### **4. Contact SMC beforehand and take special consideration of safety measures if the product is to be used in any of the following conditions.**

1. Conditions and environments outside of the given specifications, or use outdoors or in a place exposed to direct sunlight.

2. Installation on equipment in conjunction with atomic energy, railways, air navigation, space, shipping, vehicles, military, medical treatment, combustion and recreation, or equipment in contact with food and beverages, emergency stop circuits, clutch and brake circuits in press applications, safety equipment or other applications unsuitable for the standard specifications described in the product catalogue.

3. An application which could have negative effects on people, property, or animals requiring special safety analysis.

4. Use in an interlock circuit, which requires the provision of double interlock for possible failure by using a mechanical protective function, and periodical checks to confirm proper operation.



# Safety Instructions

## ⚠ Caution

### **1. The product is provided for use in manufacturing industries.**

The product herein described is basically provided for peaceful use in manufacturing industries.

If considering using the product in other industries, consult SMC beforehand and exchange specifications or a contract if necessary.

If anything is unclear, contact your nearest sales branch.

## Limited warranty and Disclaimer/Compliance Requirements

The product used is subject to the following “Limited warranty and Disclaimer” and “Compliance Requirements”.

Read and accept them before using the product.

### Limited warranty and Disclaimer

#### **1. The warranty period of the product is 1 year in service or 1.5 years after the product is delivered.<sup>Note 2)</sup>**

**Also, the product may have specified durability, running distance or replacement parts. Please consult your nearest sales branch.**

#### **2. For any failure or damage reported within the warranty period which is clearly our responsibility, a replacement product or necessary parts will be provided.**

**This limited warranty applies only to our product independently, and not to any other damage incurred due to the failure of the product.**

#### **3. Prior to using SMC products, please read and understand the warranty terms and disclaimers noted in the specified catalog for the particular products.**

**Note 2) Vacuum pads are excluded from this 1 year warranty.**

A vacuum pad is a consumable part, so it is warranted for a year after it is delivered.

Also, even within the warranty period, the wear of a product due to the use of the vacuum pad or failure due to the deterioration of rubber material are not covered by the limited warranty.

### Compliance Requirements

**When the product is exported, strictly follow the laws required by the Ministry of Economy, Trade and Industry (Foreign Exchange and Foreign Trade Control Law).**



# Series VF

## Specific Product Precautions 1

Be sure to read before handling.

Refer to back pages 1 and 2 for Safety Instructions, "Handling Precautions for SMC Products" (M-E03-3) for 3/4/5 Port Solenoid Valves Precautions.

### Manual Override

#### Warning

Without an electric signal for the solenoid valve the manual override is used for switching the main valve. **Connected actuator is started by manual operation. Use the manual override after confirming that there is no danger.**

##### ■ Non-locking push type

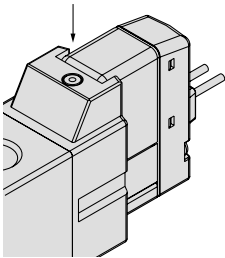

Push down on the manual override with a small screwdriver until it stops. Release the screwdriver and the manual override will return.

##### ■ Push-turn locking slotted type

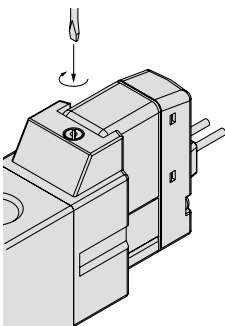

Locked condition

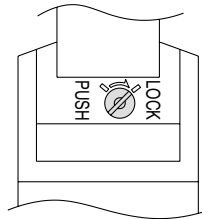

Push down on the manual override with a small flat head screwdriver until it stops. Turn it clockwise by 90° to lock it. Turn it counterclockwise to release it.

##### ■ Push-turn locking lever type

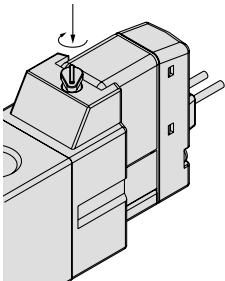

Locked condition

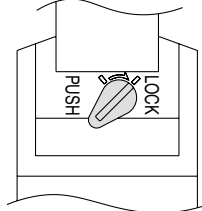

After pushing down, turn in the direction of the arrow. If it is not turned, it can be operated the same way as the non-locking push type.

#### Caution

When locking the manual override with the push-turn locking type (D or E type), be sure to push it down before turning. Turning without first pushing it down can cause damage to the manual override and other trouble such as air leakage, etc. Do not apply excessive torque when turning the locking type manual override. (0.1 N·m)

### How to Use L/M-Type Plug Connector

#### Caution

##### 1. Attaching and detaching connectors

- To attach a connector, hold the lever and connector unit between your fingers and insert straight onto the pins of the solenoid valve so that the lever's pawl is pushed into the groove and locks.
- To detach a connector, remove the pawl from the groove by pushing the lever downward with your thumb, and pull the connector straight out.

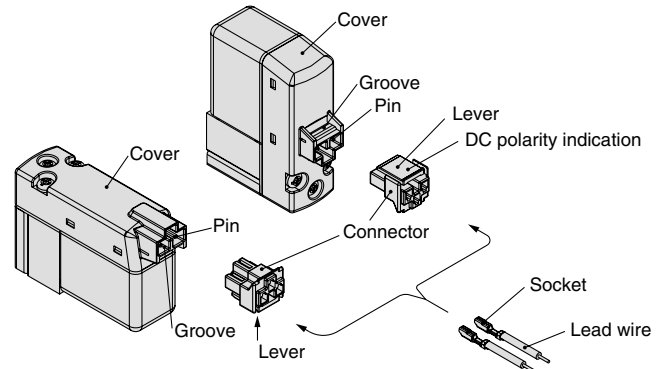

##### 2. Crimping lead wires and sockets

Not necessary if ordering the lead wire pre-connected model. Strip 3.2 to 3.7 mm at the end of the lead wires, insert the ends of the core wires evenly into the sockets, and then crimp with a crimping tool. When this is done, take care that the coverings of the lead wires do not enter the core wire crimping area. (Please contact SMC for details on the crimping tool.)

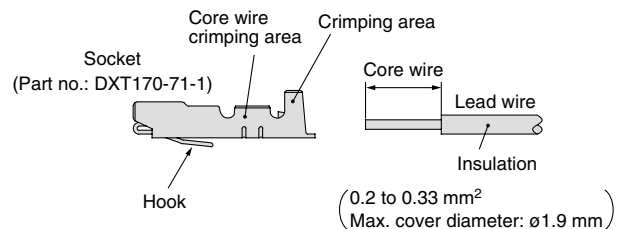

##### 3. Attaching and detaching sockets with lead wire

###### • Attaching

Insert the sockets into the square holes of the connector (+, - indication), and continue to push the sockets all the way in until they lock by hooking into the seats in the connector. (When they are pushed in, their hooks open and they are locked automatically.) Then, confirm that they are locked by pulling lightly on the lead wires.

###### • Detaching

To detach a socket from a connector, pull out the lead wire while pressing the socket's hook with a stick having a thin tip (approx. 1 mm). If the socket will be used again, first spread the hook outward.

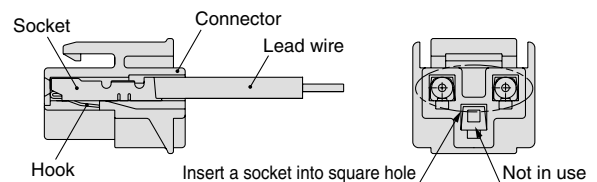



# Series VF

## Specific Product Precautions 2

Be sure to read before handling.

Refer to back pages 1 and 2 for Safety Instructions, "Handling Precautions for SMC Products" (M-E03-3) for 3/4/5 Port Solenoid Valves Precautions.

### Plug Connector Lead Wire Length

#### Caution

Plug connector lead wires have a standard length of 300 mm, however, the following lengths are also available.

#### How to Order Connector Assembly

- DC : V200-30-4A-
- 100 VAC : V200-30-1A-
- 200 VAC : V200-30-2A-
- AC other voltages: V200-30-3A-

Without lead wire : V200-30-A  
(With connector and 2 sockets)

#### Lead wire length

—	300 mm
6	600 mm
10	1000 mm
15	1500 mm
20	2000 mm
25	2500 mm
30	3000 mm
50	5000 mm

#### How to Order

Include the connector assembly part number together with the part number for the plug connector's solenoid valve without connector.

(Example) 2000 mm lead wire length

<b>DC</b>	<b>AC</b>
VF3130-5LO1-02	VF3130-1LO1-02
V200-30-4A-20	V200-30-1A-20

### How to Use DIN Terminal

The DIN terminal type with an IP65 (enclosure) is protected against dust and water, however, it must not be used in water.

#### Caution

##### Connection

- Loosen the set screw and pull the connector out of the solenoid valve terminal block.
- After removing the set screw, insert a flat head screwdriver, etc. into the notch on the bottom of the terminal block and pry it open, separating the terminal block and the housing.
- Loosen the terminal screws on the terminal block, insert the core of the lead wire into the terminal, and attach securely with the terminal screws.  
In addition, when using the DC mode type with a surge voltage suppressor (polar: S and Z types), connect wires corresponding to the polarity (+ or -) that is printed on the terminal block.
- Tighten the ground nut to secure the wire.  
In the case of connecting wires, select cable cords carefully because if those out of the specified range ( $\phi 4.5$  to  $\phi 7$ ) are used, it will not be able to satisfy IP65 (enclosure). Tighten the ground nut and set screw within the specified range of torque.

##### Changing the entry direction

After separating terminal block and housing, the cord entry direction can be changed by attaching the housing in the opposite direction.

Note) Make sure not to damage elements, etc., with the lead wires of the cord.

##### Precautions

Plug in and pull out the connector vertically without tilting to one side.

##### Applicable cable

Cable O.D.:  $\phi 4.5$  to  $\phi 7$   
(Reference)  $0.5 \text{ mm}^2$  to  $1.5 \text{ mm}^2$ , 2-core or 3-core, equivalent to JIS C 3306

##### Applicable crimped terminal

O terminal: R1.25-4M that is specified in JIS C 2805  
Y terminal: 1.25-3L, which is released by JST Mfg. Co., Ltd.  
Stick terminal: Size 1.5 or shorter

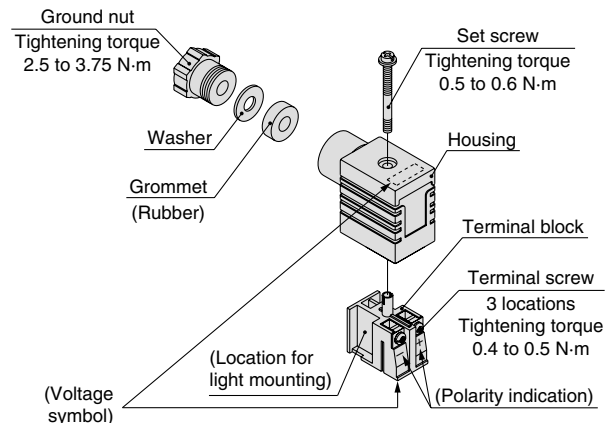



# Series VF

## Specific Product Precautions 3

Be sure to read before handling.

Refer to back pages 1 and 2 for Safety Instructions, "Handling Precautions for SMC Products" (M-E03-3) for 3/4/5 Port Solenoid Valves Precautions.

### DIN (EN175301-803) Terminal

Y type DIN terminal corresponds to the DIN connector with terminal pitch 10 mm, which complies with EN175301-803B. Since the terminal pitch is different from the D type DIN connector, these two types are not interchangeable.

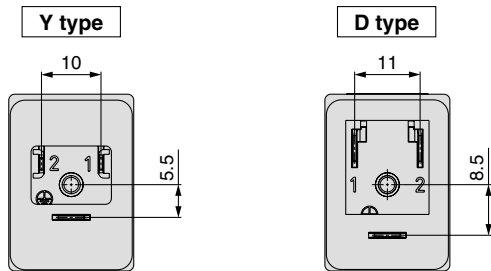

### How to Order DIN Connector

#### Caution

● Without indicator light

DC, AC, Other voltages: V200-□-1

● With indicator light

DC

Polar type (□Z) : V200-□-3-□

Non-polar type (□U) : V200-□-5-□

● Rated voltage

05	24 VDC
06	12 VDC

AC (□Z) : V200-□-7-□

Connector specification ●

61	D type
63	Y type

● Rated voltage

01	100/110 VAC [115 VAC]
02	200/220 VAC [230 VAC]
07	240 VAC

### Circuit diagram with light/installed in the connector

#### DC (□Z) circuit diagram

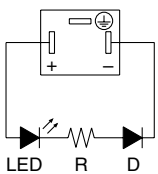

LED: Light emitting diode  
D: Protective diode  
R: Resistor

#### DC (□U) circuit diagram

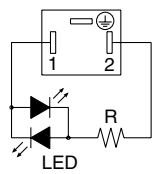

LED: Light emitting diode  
R: Resistor

#### AC (□Z) circuit diagram

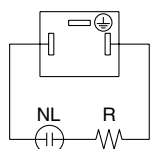

NL: Neon bulb, R: Resistor

### How to Use Conduit Terminal

#### Caution

##### Connection

1) Loosen the set screw and remove the terminal block cover from the terminal block.

2) Loosen the terminal screws on the terminal block, insert the core of the lead wire or crimped terminal into the terminal, and attach securely with the terminal screws.

In addition, when using the DC mode type with a surge voltage suppressor (polar: S and Z types), connect wires to terminal 1 and 2 corresponding to the polarity (+ or -) as shown on the right figure.



3) Secure the cord by fastening the ground nut.

In the case of connecting wires, select cable cords carefully because if those out of the specified range (ø4.5 to ø7) are used, it will not be able to satisfy IP65 (enclosure).

Tighten the ground nut and set screw within the specified range of torque.

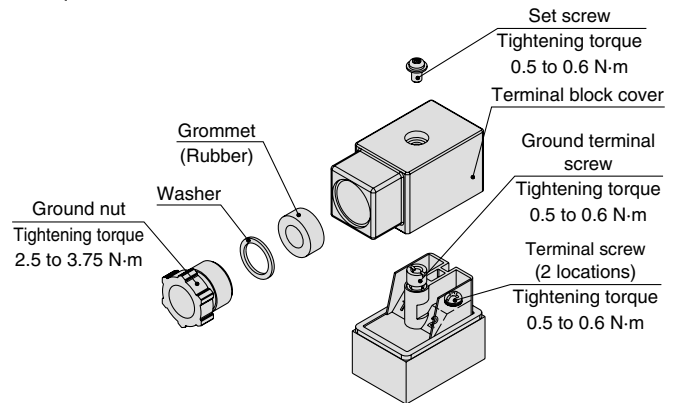

#### Applicable cable

Cable O.D.: ø4.5 to ø7

(Reference) 0.5 mm<sup>2</sup> to 1.5 mm<sup>2</sup>, 2-core or 3-core, equivalent to JIS C 3306

#### Applicable crimped terminal

O terminal: Equivalent to R1.25-3 that is specified in JIS C 2805  
Y terminal: Equivalent to 1.25-3, which is released by JST Mfg. Co., Ltd.

Note) Use O terminal when a ground terminal is used.





# Series VF

## Specific Product Precautions 4

Be sure to read before handling.

Refer to back pages 1 and 2 for Safety Instructions, "Handling Precautions for SMC Products" (M-E03-3) for 3/4/5 Port Solenoid Valves Precautions.

### Leakage Voltage

#### Caution

Especially when a resistor and a switching element are used in parallel or C-R device (surge voltage suppressor) is used for the protection of the switching device, note that leakage voltage will be increased by passing leakage voltage through the resistor and C-R device. Therefore, suppressor residual leakage voltage should be as follows.

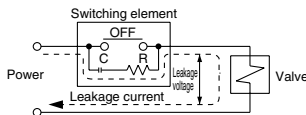

#### DC coil

3% or less of the rated voltage

#### AC coil

8% or less of the rated voltage

### Continuous Duty

#### Caution

- If a valve is energized continuously for long periods of time, the rise in temperature due to heat-up of the coil assembly may cause a decline in solenoid valve performance, reduce service life, or have adverse effects on peripheral equipment. If the valve is energized continuously for long periods of time, or the total energizing time per day becomes longer than the non-energizing time, use a valve with power saving circuit.
- When the valve is mounted onto a control panel, take measures against radiation in order to keep the valve temperature within the specified range.

### Light/Surge Voltage Suppressor

#### Caution

<DC>

##### ■ Polar type

With surge voltage suppressor (□S)

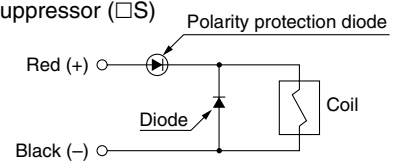

##### ● Grommet or L/M-type plug connector

With light/surge voltage suppressor (□Z)

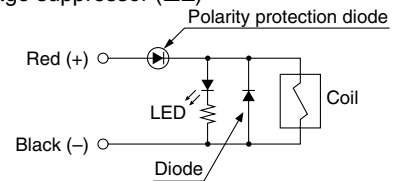

##### ● DIN or Conduit terminal

With light/surge voltage suppressor (□Z)

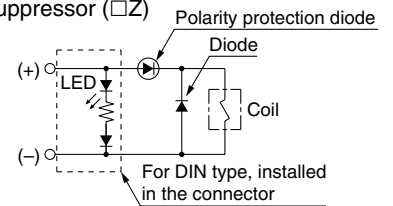

##### ■ Non-polar type

With surge voltage suppressor (□R)

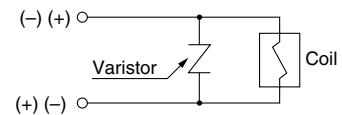

##### ● Grommet or L/M-type plug connector

With light/surge voltage suppressor (□U)

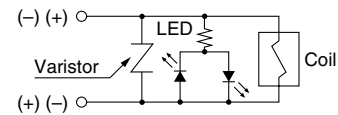

##### ● DIN or Conduit terminal

With light/surge voltage suppressor (□U)

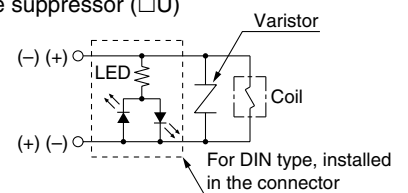

- Please connect correctly the lead wires to + (positive) and - (negative) indications on the connector. (For non-polar type, the lead wires can be connected to either one.)
- When the valve with polarity protection diode is used, the voltage will drop by approx. 1 V. Therefore, pay attention to the allowable voltage fluctuation (For details, refer to the solenoid specification of each type of valve).
- Solenoids, whose lead wires have been pre-wired: + (positive) side red and - (negative) side black.



# Series VF Specific Product Precautions 5

Be sure to read before handling.

Refer to back pages 1 and 2 for Safety Instructions, "Handling Precautions for SMC Products" (M-E03-3) for 3/4/5 Port Solenoid Valves Precautions.

## Light/Surge Voltage Suppressor

### Caution

#### With power saving circuit

Power consumption is decreased by approx. 1/3 by reducing the wattage required to hold the valve in an energized state. (Effective energizing time is over 40 ms at 24 VDC.)

Refer to the electrical power waveform as shown below.

#### <Electrical power waveform of energy saving type>

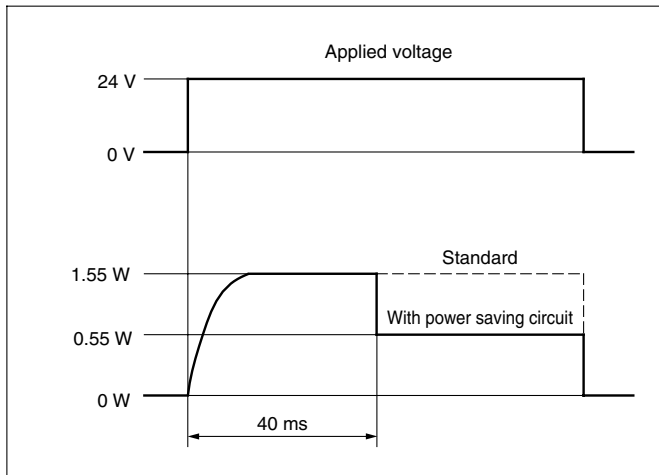

- Since the voltage will drop by approx. 0.5 V due to the transistor, pay attention to the allowable voltage fluctuation. (For details, refer to the solenoid specifications of each type of valve.)

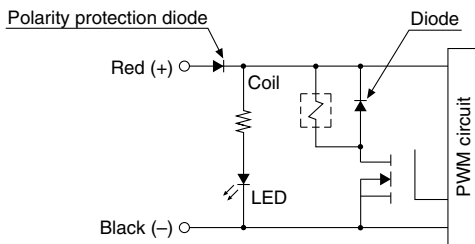

#### <AC>

There is no S option, since a rectifier prevents surge voltage generation.

- Grommet or L/M-type plug connector  
With light/surge voltage suppressor (□Z)

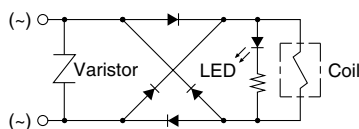

- DIN or Conduit terminal  
With light/surge voltage suppressor (□Z)

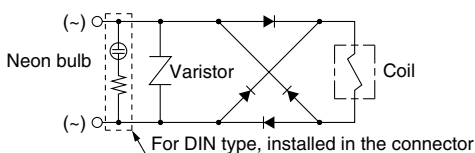

## Light/Surge Voltage Suppressor

### Caution

#### Residual voltage of the surge voltage suppressor

Note) if a varistor or diode surge voltage suppressor is used, there is some residual voltage to the protection element and rated voltage. Therefore, refer to the table below and pay attention to the surge voltage protection on the controller side. Also, since the response time does change, refer to the specifications on page 2 and 16.

#### Residual Voltage

Surge voltage suppressor	DC		AC
	24 V	12 V	
S, Z	Approx. 1 V		Approx. 1 V
R, U	Approx. 47 V	Approx. 32 V	—

#### Countermeasure for Surge Voltage Intrusion

### Caution

With non-polar type solenoid valves, at times of sudden interruption of the loading power supply, such as emergency shutdown, surge voltage intrusion may be generated from loading equipment with a large capacity (power consumption), and the solenoid valve in a de-energized state may switch over (see Figure 1).

When installing a breaker circuit for the loading power supply, consider using a solenoid valve with polarity (with polarity protection diode), or install a surge absorption diode between the loading equipment COM line and the output equipment COM line (see Figure 2).

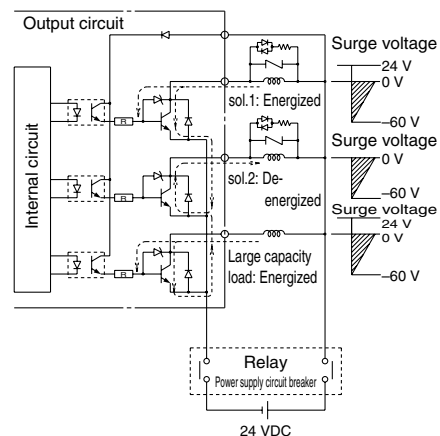

Figure 1. Surge intrusion circuit example (NPN outlet example) (24 VDC)

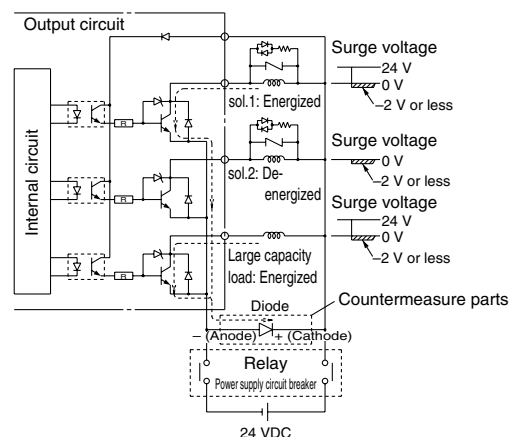

Figure 2. Surge intrusion circuit example (NPN outlet example) (24 VDC)



# Series VF

## Specific Product Precautions 6

Be sure to read before handling.

Refer to back pages 1 and 2 for Safety Instructions, "Handling Precautions for SMC Products" (M-E03-3) for 3/4/5 Port Solenoid Valves Precautions.

### One-touch Fittings Precautions

#### Caution

When fittings are used, they may interfere with one another depending on their types and sizes. Therefore, the dimensions of the fittings to be used should first be confirmed in their respective catalogues.

Fittings whose compliance with the VF series is already confirmed are stated below. If the fitting within the applicable range is selected, there will not be any interference.

#### Applicable Fittings: Series KQ2H, KQ2S

Series	Model	Piping port	Port size	Applicable tubing O.D.						
				ø3.2	ø4	ø6	ø8	ø10	ø12	ø16
VF1000	VF1□20-□□-M5	4(A), 2(B)	M5	██████████						
		5(EA), 3(EB)	M5	██████████						
	VF1□20-□□-01	4(A), 2(B)	1/8	██████████						
		5(EA), 3(EB)	M5	██████████						
	VF1□3□-□□-M5	4(A), 2(B)	M5	██████████						
	VF1□3□-□□-01	4(A), 2(B)	1/8	██████████						
	Type 30 manifold base	1(P), 5/3(R)	1/8	██████████						
	Type 31 manifold base	1(P)	1/8	██████████						
5(EA), 3(EB)		M5	██████████							

Series	Model	Piping port	Port size	Applicable tubing O.D.					
				ø3.2	ø4	ø6	ø8	ø10	ø12
VF3000	VF3□3□-□□-01	4(A), 2(B)	1/8	██████████					
		1(P), 5(EA), 3(EB)	1/8	██████████					
	VF3□3□-□□-02	4(A), 2(B)	1/4	██████████					
		1(P), 5(EA), 3(EB)	P: 1/4, EA, EB: 1/8	██████████					
	VF3□4□-□□-02	4(A), 2(B)	1/4	██████████					
		1(P), 5(EA), 3(EB)	1/4	██████████					
	VF3□4□-□□-03	4(A), 2(B)	3/8		██████████				
		1(P), 5(EA), 3(EB)	3/8		██████████				
	Type 30 manifold base	1(P), 5(R), 3(R)	1/4	██████████					
	Type 40 manifold base	4(A), 2(B)	1/4	██████████					
1(P), 5(R), 3(R)		1/4	██████████						

Series	Model	Piping port	Port size	Applicable tubing O.D.						
				ø3.2	ø4	ø6	ø8	ø10	ø12	ø16
VF5000	VF5□2□-□□-02	4(A), 2(B)	1/4	██████████						
		1(P), 5(EA), 3(EB)	1/4	██████████						
	VF5□2□-□□-03	4(A), 2(B)	3/8		██████████					
		1(P), 5(EA), 3(EB)	3/8		██████████					
	VF5□44-□□-02	4(A), 2(B)	1/4	██████████						
		1(P), 5(EA), 3(EB)	1/4	██████████						
	VF5□44-□□-03	4(A), 2(B)	3/8		██████████					
		1(P), 5(EA), 3(EB)	3/8		██████████					
	VF5□44-□□-04	4(A), 2(B)	1/2			██████████				
		1(P), 5(EA), 3(EB)	1/2			██████████				
	Type 20 manifold base	1(P), 5(R), 3(R)	3/8		██████████					
	Type 21 manifold base	1(P), 5(R), 3(R)	1/2		██████████					
	Type 40 manifold base	4(A), 2(B)	1/4	██████████						
		1(P), 5(R), 3(R)	3/8		██████████					

**EUROPEAN SUBSIDIARIES:**

**Austria**

SMC Pneumatik GmbH (Austria).  
Girakstrasse 8, A-2100 Korneuburg  
Phone: +43 2262-622800, Fax: +43 2262-62285  
E-mail: office@smc.at  
http://www.smc.at

**France**

SMC Pneumatique, S.A.  
1, Boulevard de Strasbourg, Parc Gustave Eiffel  
Bussy Saint Georges F-77607 Marne La Vallée Cedex 3  
Phone: +33 (0)1-6476 1000, Fax: +33 (0)1-6476 1010  
E-mail: contact@smc-france.fr  
http://www.smc-france.fr

**Netherlands**

SMC Pneumatics BV  
De Ruyterkade 120, NL-1011 AB Amsterdam  
Phone: +31 (0)20-5318888, Fax: +31 (0)20-5318880  
E-mail: info@smcpneumatics.nl  
http://www.smcneumatics.nl

**Spain**

SMC España, S.A.  
Zuazobidea 14, 01015 Vitoria  
Phone: +34 945-184 100, Fax: +34 945-184 124  
E-mail: post@smc.smces.es  
http://www.smc.eu

**Belgium**

SMC Pneumatics N.V./S.A.  
Nijverheidsstraat 20, B-2160 Wommelgem  
Phone: +32 (0)3-355-1464, Fax: +32 (0)3-355-1466  
E-mail: info@smcpneumatics.be  
http://www.smcneumatics.be

**Germany**

SMC Pneumatik GmbH  
Boschring 13-15, D-63329 Egelsbach  
Phone: +49 (0)6103-4020, Fax: +49 (0)6103-402139  
E-mail: info@smc-pneumatik.de  
http://www.smc-pneumatik.de

**Norway**

SMC Pneumatics Norway A/S  
Vollsveien 13 C, Granfos Næringspark N-1366 Lysaker  
Tel: +47 67 12 90 20, Fax: +47 67 12 90 21  
E-mail: post@smc-norge.no  
http://www.smc-norge.no

**Sweden**

SMC Pneumatics Sweden AB  
Ekhagsvägen 29-31, S-141 71 Huddinge  
Phone: +46 (0)8-603 12 00, Fax: +46 (0)8-603 12 90  
E-mail: post@smcpneumatics.se  
http://www.smc.nu

**Bulgaria**

SMC Industrial Automation Bulgaria EOOD  
Business Park Sofia, Building 8 - 6th floor, BG-1715 Sofia  
Phone: +359 2 9744492, Fax: +359 2 9744519  
E-mail: office@smc.bg  
http://www.smc.bg

**Greece**

SMC Hellas EPE  
Anagenniseos 7-9 - P.C. 14342, N. Philadelphia, Athens  
Phone: +30-210-2717265, Fax: +30-210-2717766  
E-mail: sales@smchellas.gr  
http://www.smchellas.gr

**Poland**

SMC Industrial Automation Polska Sp.z.o.o.  
ul. Poloneza 89, PL-02-826 Warszawa  
Phone: +48 22 211 9600, Fax: +48 22 211 9617  
E-mail: office@smc.pl  
http://www.smc.pl

**Switzerland**

SMC Pneumatik AG  
Dorfstrasse 7, CH-8484 Weisslingen  
Phone: +41 (0)52-396-3131, Fax: +41 (0)52-396-3191  
E-mail: info@smc.ch  
http://www.smc.ch

**Croatia**

SMC Industrijska automatika d.o.o.  
Crnomerec 12, HR-10000 ZAGREB  
Phone: +385 1 377 66 74, Fax: +385 1 377 66 74  
E-mail: office@smc.hr  
http://www.smc.hr

**Hungary**

SMC Hungary Ipari Automatizálási Kft.  
Torbágy út 19, H-2045 Törökbalint  
Phone: +36 23 511 390, Fax: +36 23 511 391  
E-mail: office@smc.hu  
http://www.smc.hu

**Portugal**

SMC Sucursal Portugal, S.A.  
Rua de Eng<sup>o</sup> Ferreira Dias 452, 4100-246 Porto  
Phone: +351 226 166 570, Fax: +351 226 166 589  
E-mail: postpt@smc.smces.es  
http://www.smc.eu

**Turkey**

Entek Pnömatik San. ve Tic. A\*.  
Perpa Ticaret Merkezi B Blok Kat:11 No: 1625, TR-34386, Okmeydanı, Istanbul  
Phone: +90 (0)212-444-0762, Fax: +90 (0)212-221-1519  
E-mail: smc@entek.com.tr  
http://www.entek.com.tr

**Czech Republic**

SMC Industrial Automation CZ s.r.o.  
Hudcova 78a, CZ-61200 Brno  
Phone: +420 5 414 24611, Fax: +420 5 412 18034  
E-mail: office@smc.cz  
http://www.smc.cz

**Ireland**

SMC Pneumatics (Ireland) Ltd.  
2002 Citywest Business Campus, Naas Road, Saggart, Co. Dublin  
Phone: +353 (0)1-403 9000, Fax: +353 (0)1-464-0500  
E-mail: sales@smcpneumatics.ie  
http://www.smcneumatics.ie

**Romania**

SMC Romania srl  
Str Frunzei 29, Sector 2, Bucharest  
Phone: +40 213205111, Fax: +40 213261489  
E-mail: smcromania@smcromania.ro  
http://www.smcromania.ro

**UK**

SMC Pneumatics (UK) Ltd  
Vincent Avenue, Crownhill, Milton Keynes, MK8 0AN  
Phone: +44 (0)845 121 5122 Fax: +44 (0)1908-555064  
E-mail: sales@smcpneumatics.co.uk  
http://www.smcneumatics.co.uk

**Denmark**

SMC Pneumatik A/S  
Egeskovvej 1, DK-8700 Horsens  
Phone: +45 70252900, Fax: +45 70252901  
E-mail: smc@smcdk.com  
http://www.smcdk.com

**Italy**

SMC Italia S.p.A  
Via Garibaldi 62, I-20061 Carugate, (Milano)  
Phone: +39 (0)2-92711, Fax: +39 (0)2-9271365  
E-mail: mailbox@smcitalia.it  
http://www.smcitalia.it

**Russia**

SMC Pneumatik LLC.  
4B Sverdlovskaja nab, St. Petersburg 195009  
Phone: +7 812 718 5445, Fax: +7 812 718 5449  
E-mail: info@smc-pneumatik.ru  
http://www.smc-pneumatik.ru

**Estonia**

SMC Pneumatics Estonia OÜ  
Laki 12, 106 21 Tallinn  
Phone: +372 6510370, Fax: +372 65110371  
E-mail: smc@smcpneumatics.ee  
http://www.smcneumatics.ee

**Latvia**

SMC Pneumatics Latvia SIA  
Dzelzavas str. 120g, Riga LV-1021, LATVIA  
Phone: +371 67817700, Fax: +371 67817701  
E-mail: info@smclv.lv  
http://www.smclv.lv

**Slovakia**

SMC Priemyselna Automatizácia, s.r.o.  
Fatranská 1223, 01301 Teplicka Nad Váhom  
Phone: +421 41 3213212 - 6 Fax: +421 41 3213210  
E-mail: office@smc.sk  
http://www.smc.sk

**Finland**

SMC Pneumatics Finland Oy  
PL72, Tiistinniityntie 4, SF-02231 ESPOO  
Phone: +358 207 513513, Fax: +358 207 513599  
E-mail: smcfin@smc.fi  
http://www.smc.fi

**Lithuania**

SMC Pneumatics Lietuva, UAB  
Oslo g.1, LT-04123 Vilnius  
Phone: +370 5 2308118, Fax: +370 5 2648126  
E-mail: info@smclt.lt  
http://www.smclt.lt

**Slovenia**

SMC industrijska Avtomatika d.o.o.  
Mirska cesta 7, SI-8210 Trebnje  
Phone: +386 7 3885412 Fax: +386 7 3885435  
E-mail: office@smc.si  
http://www.smc.si

**OTHER SUBSIDIARIES WORLDWIDE:**

ARGENTINA, AUSTRALIA, BOLIVIA, BRASIL, CANADA, CHILE,  
CHINA, HONG KONG, INDIA, INDONESIA, MALAYSIA, MEXICO,  
NEW ZEALAND, PHILIPPINES, SINGAPORE, SOUTH KOREA,  
TAIWAN, THAILAND, USA, VENEZUELA

<http://www.smc.eu>  
<http://www.smcworld.com>