

IEC Appliance Inlet C20 or C24, Split panel or screw-on mounting, PCB Terminal



Split panel mounting, Screw-on PCB,
 Additional earth terminal 90° to connector axis



Screw-on panel mounting,
 Snap-in PCB 1.6 mm,
 Additional earth terminal in connector axis



Split panel mounting, Snap-in PCB 1.6 mm,
 Additional earth terminal 90° to connector axis



See below:

[Approvals and Compliances](#)

Description

- Panel mount :
 Splitpanel (sandwich) or screw-on from backside
- Appliance Inlet , Pin temperature 70 °C , protection class I or II
- V-Lock notch standard
- Additional ground terminal
- Safety of electrical appliances for household and similar purposes.
 Meets the requirements for appliances in unattended use. This includes the enhanced requirements of glow wire tests acc. to IEC 60695-2-11 or -12 & -13.
- Variants with protection cover on rear side
- For PCB mounting: screw-on or snap-in 1.6 mm

Other versions on request

- Further colours on request

Weblinks

[pdf data sheet](#), [html datasheet](#), [General Product Information](#), [Approvals](#), [Distributor-Stock-Check](#), [Accessories](#), [Detailed request for product](#)

Technical Data

Ratings IEC	16A / 250VAC; 50Hz
Ratings UL/CSA	20A / 250VAC; 60Hz
Dielectric Strength	> 1.5kVAC between L-N > 1.5kVAC between L/N-PE (1 min/50Hz)
Allowable Operation Temperature	-25 °C to 70 °C
IP-Protection	front side IP20 acc. to IEC 60529
Protection against electric shock	Suitable for appliances with protection class I or II acc. to IEC 61140
Terminal	PCB terminals , additional ground terminal
Panel Thickness S	for sandwich mounting 1/1.2/1.5/2/2.5/3/4mm
Material: Housing	Thermoplastic, black, UL 94V-0

Appliance inlet/-outlet	C20 or C24 acc. to IEC 60320-1 UL 60320-1, CSA C22.2 no. 60320-1 (for cold conditions) pin-temperature 70 °C, 16A, Protection Class I or II
-------------------------	---

Approvals and Compliances

Detailed information on product approvals, code requirements, usage instructions and detailed test conditions can be looked up in [Details about Approvals](#)

SCHURTER products are designed for use in industrial environments. They have approvals from independent testing bodies according to national and international standards. Products with specific characteristics and requirements such as required in the automotive sector according to IATF 16949, medical technology according to ISO 13485 or in the aerospace industry can be offered exclusively with customer-specific, individual agreements by SCHURTER.

Approvals



The approval mark is used by the testing authorities to certify compliance with the safety requirements placed on electronic products.

Approval Reference Type: GSP4

Approval Logo	Certificates	Certification Body	Description
	VDE Approvals	VDE	Certificate Number: 40035923
	UL Approvals	UL	UR File Number: E96454
	CCC Approvals	CCC	CCC Certificate Number: 2020180204014249, 2020180204014250



Product standards

Product standards that are referenced

Organization	Design	Standard	Description
	Designed according to	IEC 60320-1	Appliance couplers for household and similar general purposes
	Designed according to	UL 60320-1	Standard for Attachment Plugs and Receptacles
	Designed according to	CSA C22.2 no. 60320-1	General Use Receptacles, Attachment Plugs, and Similar Wiring Devices







Application standards

Application standards where the product can be used

Organization	Design	Standard	Description
	Suitable for applications acc.	IEC/UL 62368-1	Audio/video, information and communication technology equipment - Part 1: Safety requirements
	Suitable for applications acc.	IEC 60335-1	Safety of electrical appliances for household and similar purposes. Meets the requirements for appliances in unattended use. This includes the enhanced requirements of glow wire tests acc. to IEC 60695-2-11 or -12 & -13.

Compliances

The product complies with following Guide Lines

Identification	Details	Initiator	Description
	CE declaration of conformity	SCHURTER AG	The CE marking declares that the product complies with the applicable requirements laid down in the harmonisation of Community legislation on its affixing in accordance with EU Regulation 765/2008.
	UKCA declaration of conformity	SCHURTER AG	The UKCA marking declares that the product complies with the applicable requirements laid down in the British Amendment of Regulation (EC) 765/2008.
	RoHS	SCHURTER AG	Directive RoHS 2011/65/EU, Amendment (EU) 2015/863
	China RoHS	SCHURTER AG	The law SJ / T 11363-2006 (China RoHS) has been in force since 1 March 2007. It is similar to the EU directive RoHS.
	REACH	SCHURTER AG	On 1 June 2007, Regulation (EC) No 1907/2006 on the Registration, Evaluation, Authorization and Restriction of Chemicals 1 (abbreviated as "REACH") entered into force.
		SCHURTER AG	V-Lock system are based on a matching plug-dose combination. The connector is equipped with a notch intended for use with the latching cordset. The cord latching system prevents against accidental removal of the cordset.
	White Paper Glow wire test	SCHURTER AG	Meets the requirements of IEC 60335-1 for appliances in unattended use. This includes the enhanced requirements of glow wire tests acc. to IEC 60695-2-11 or -12 & -13.

Dimensions [mm]

Split panel mounting / Snap-in on PCB

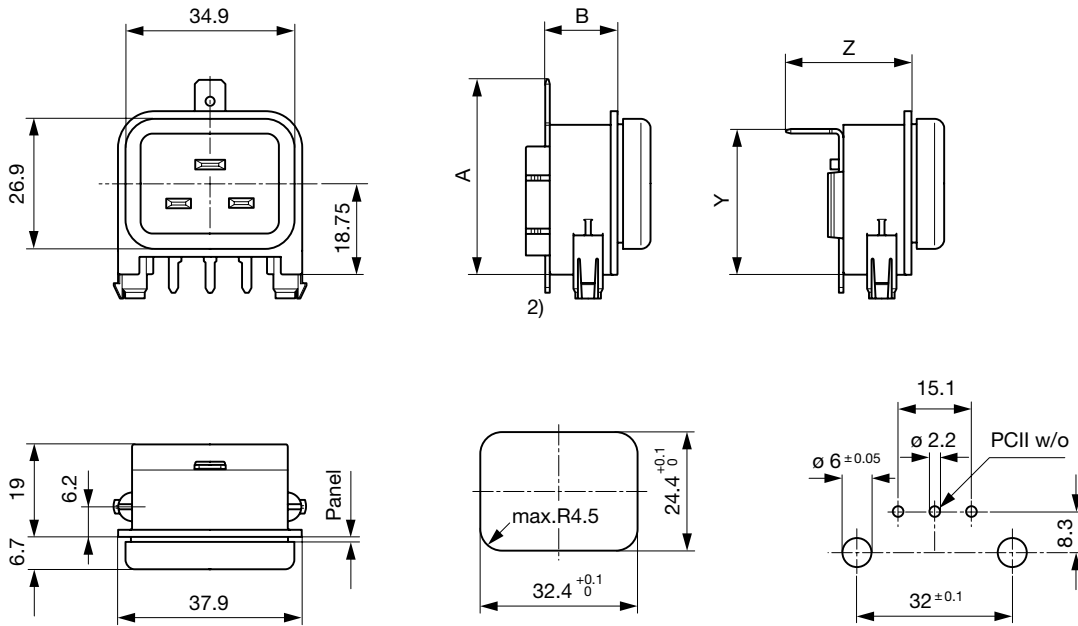

Dimension	A	B	Y	Z
Quick connect 6.3x0.8 mm	40.3	15.0	30.0	25.9
Solder	37.3	15.0	30.0	22.9

2) with protection cover

Split panel mounting / Screw-on mounting on PCB

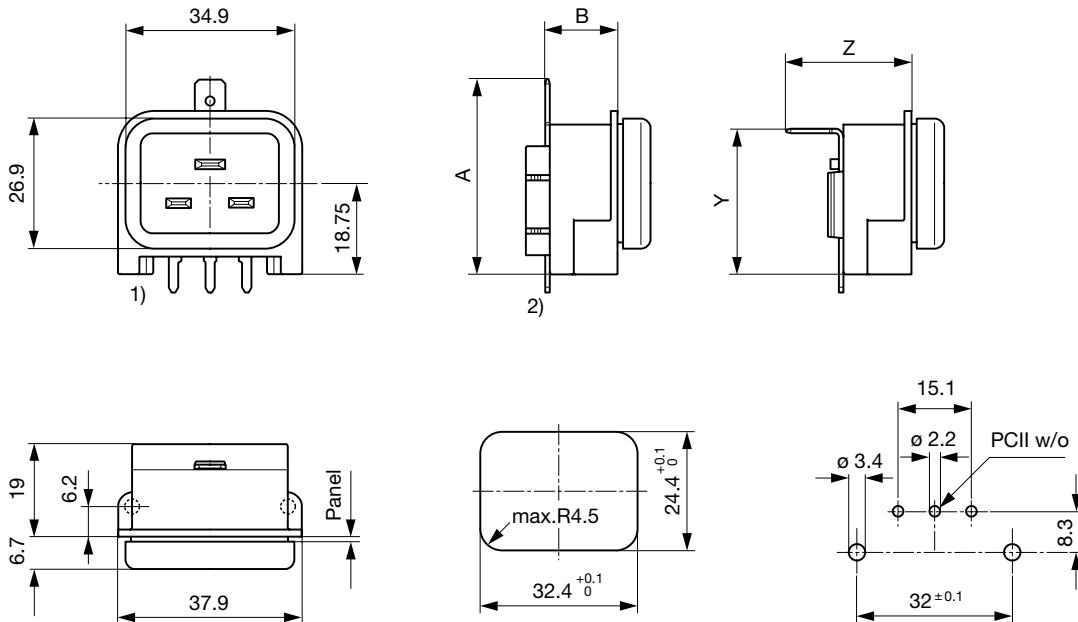

Dimension	A	B	Y	Z
Quick connect 6.3x0.8 mm	40.3	15.0	30.0	25.9
Solder	37.3	15.0	30.0	22.9

1) Mounting screw torque max. 0.3 Nm

2) with protection cover

Screw-on rear side / Snap-in on PCB

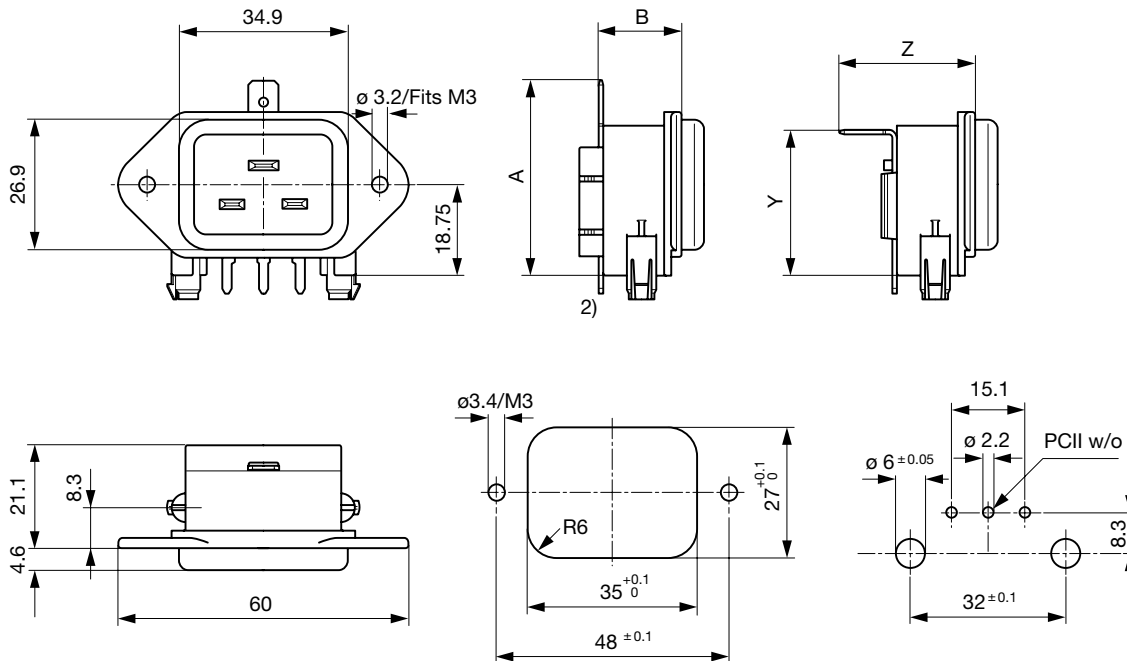

Dimension	A	B	Y	Z
Quick connect 6.3x0.8 mm	40.3	17.1	30.0	28.0
Solder	37.3	17.1	30.0	25.0

2) with protection cover

Screw-on rear side / Screw-on mounting on PCB

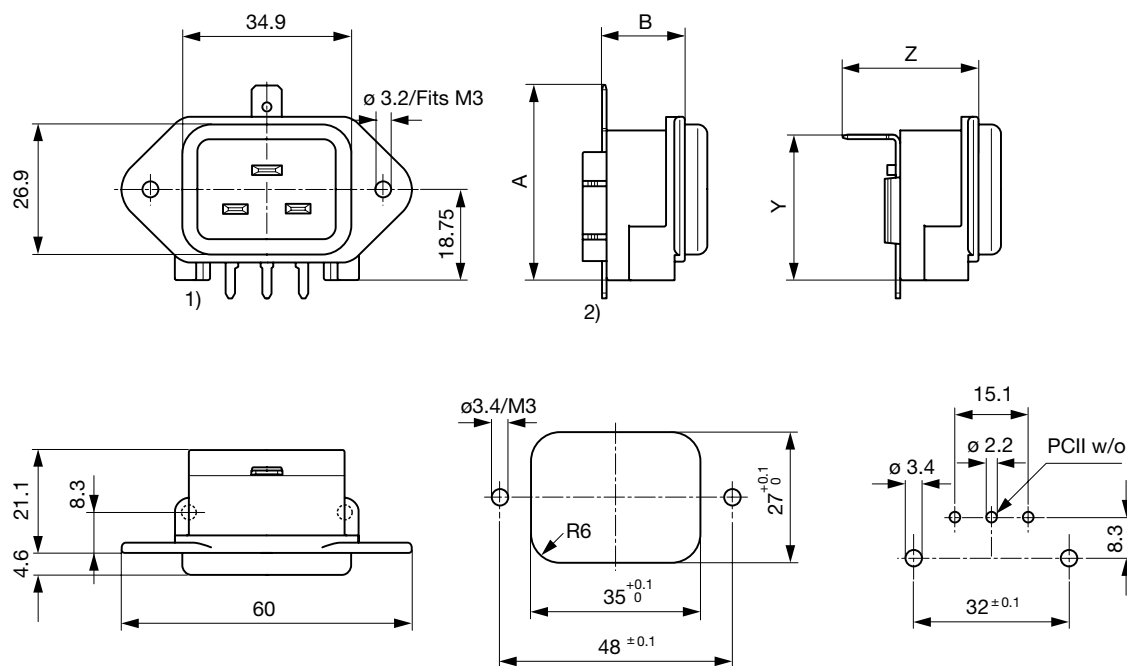

Dimension	A	B	Y	Z
Quick connect 6.3x0.8 mm	40.3	17.1	30.0	28.0
Solder	37.3	17.1	30.0	25.0

1) Mounting screw torque max. 0.3 Nm

2) with protection cover

All Variants

Protection Class	Panel mounting	Panel Thickness [mm]	PCB mounting	Additional ground terminal		Cover	Order Number
				Terminal	Terminal direction		
I	Sandwich	1.5	Screw	Quick connect terminal 6.3 x 0.8 mm	in line with PIN-axis	none	GSP4.0107.13
I	Sandwich	1.0	Screw	solder terminal	90° to connector axis	none	GSP4.010C.11
I	Sandwich	1.5	Screw	solder terminal	90° to connector axis	none	GSP4.010C.13
I	Sandwich	1.5	Snap-in	Quick connect terminal 6.3 x 0.8 mm	90° to connector axis	none	GSP4.0205.13
I	Sandwich	1.5	Snap-in	Quick connect terminal 6.3 x 0.8 mm	in line with PIN-axis	none	GSP4.0207.13
I	Sandwich	3.0	Snap-in	Quick connect terminal 6.3 x 0.8 mm	in line with PIN-axis	none	GSP4.0207.16
I	Sandwich	3.0	Snap-in	Quick connect terminal 6.3 x 0.8 mm	in line with PIN-axis	mounted	GSP4.0217.16
I	Screw	-	Screw	Quick connect terminal 6.3 x 0.8 mm	in line with PIN-axis	none	GSP4.0107.10
I	Screw	-	Snap-in	Quick connect terminal 6.3 x 0.8 mm	90° to connector axis	none	GSP4.0205.10
I	Screw	-	Snap-in	Quick connect terminal 6.3 x 0.8 mm	in line with PIN-axis	none	GSP4.0207.10
I	Screw	-	Snap-in	Quick connect terminal 6.3 x 0.8 mm	in line with PIN-axis	mounted	GSP4.0217.10
II	Sandwich	1.5	Snap-in	-	-	mounted	GSP4.0210.13

Most Popular.

Availability for all products can be searched real-time: <https://www.schurter.com/en/Stock-Check/Stock-Check-SCHURTER>

With screw mounting on PCB, 2 screws are included

Packaging unit 50 Pcs

Mating Outlets/Connectors

Category / Description



Connector Overview complete

4795, Mounting: Power Cord, Cable Connector: IEC C19	4795
4790, Mounting: Power Cord, Screw Connector: IEC C19	4790



Power Supply Cord Overview complete

Cord Sets 16 A, Europlug, 2.5 m, Connector IEC C19, H05VV-F3G1.5, black	6004.0395
Cord Sets 16 A, Interconnection, 1.0 m, Connector IEC C19, H05VV-F3G1.5, black	6020.0392
Cord Sets 16 A, Interconnection, 2.0 m, Connector IEC C19, H05VV-F3G1.5, black	6020.0394

Mating Outlets/Connectors shuttered



Power Cord Overview complete

VAC19KS, Overview, V-Lock cord retaining, diverse Connector IEC C19, diverse, black	VAC19KS
---	---------

Mouser Electronics

Authorized Distributor

Click to View Pricing, Inventory, Delivery & Lifecycle Information:

Schurter:

[GSP4.0107.10](#) [GSP4.010C.13](#) [GSP4.0207.13](#) [GSP4.0207.16](#) [GSP4.0210.13](#) [GSP4.0107.13](#) [GSP4.0207.10](#)
[GSP4.0217.10](#) [GSP4.0205.10](#) [GSP4.0217.16](#) [GSP4.010C.11](#) [GSP4.0117.13](#) [GSP4.0205.13](#) [GSP4.020C.10](#)
[GSP4.020E.13](#) [GSP4.0217.13](#) [3-104-933](#)