

REV.	ECN.NO.	MODIFY.CONTENT	DATE
A		NEW RELEASE	04/28/17
B		Add NO PATTERN AREA	09/09/18

Pin No	Signal Name	Mating Sequence	Pin No	Signal Name	Mating Sequence
A1	GND	First	B12	GND	First
A2	TX1+	Second	B11	RX1+	Second
A3	TX1-	Second	B10	RX1-	Second
A4	Vbus	First	B9	Vbus	First
A5	CC1	Second	B8	SBU2	Second
A6	D+	Second	B7	D-	Second
A7	D-	Second	B6	D+	Second
A8	SBU1	Second	B5	CC2	Second
A9	Vbus	First	B4	Vbus	First
A10	RX2-	Second	B3	TX2-	Second
A11	RX2+	Second	B2	TX2+	Second
A12	GND	First	B1	GND	First
SHELL	GND		SHELL	GND	

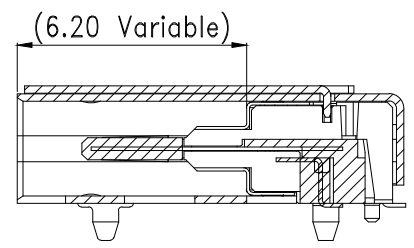

SECTION A-A

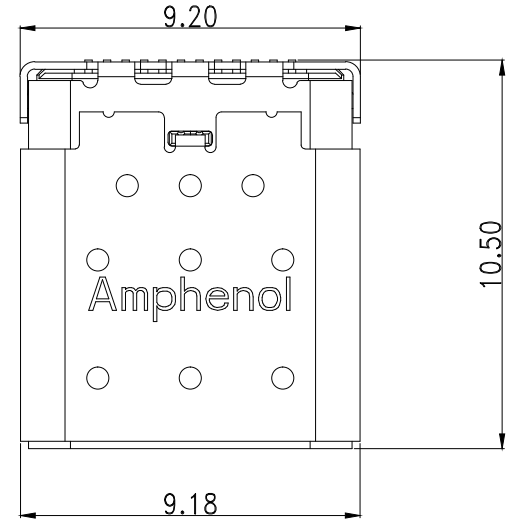
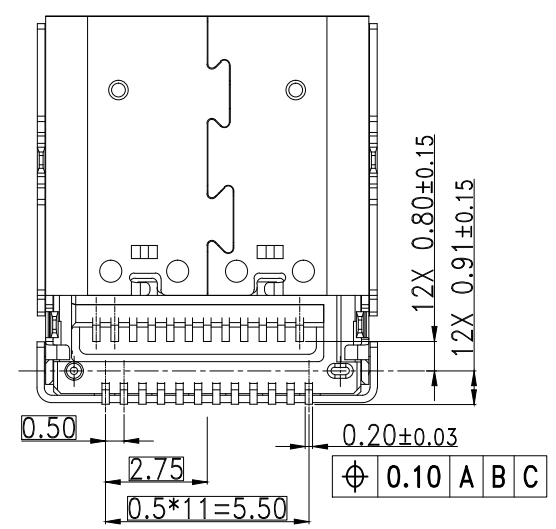
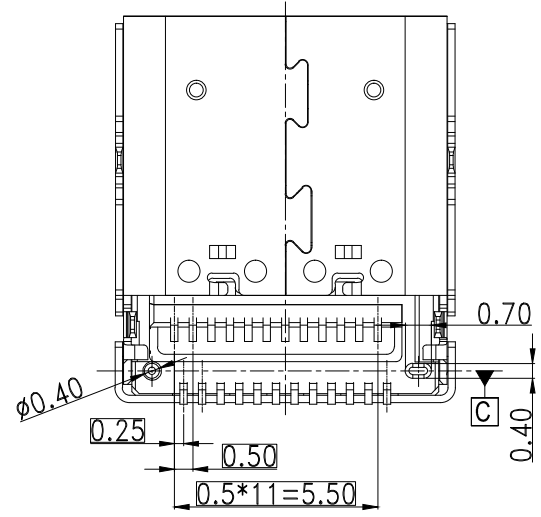
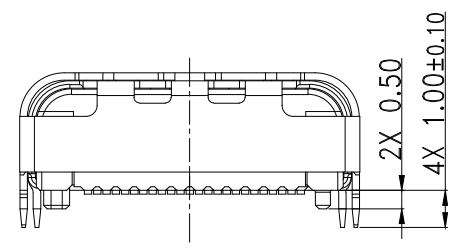
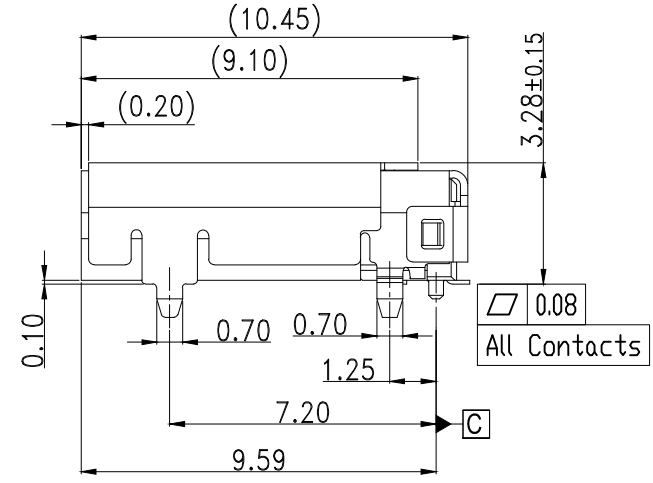
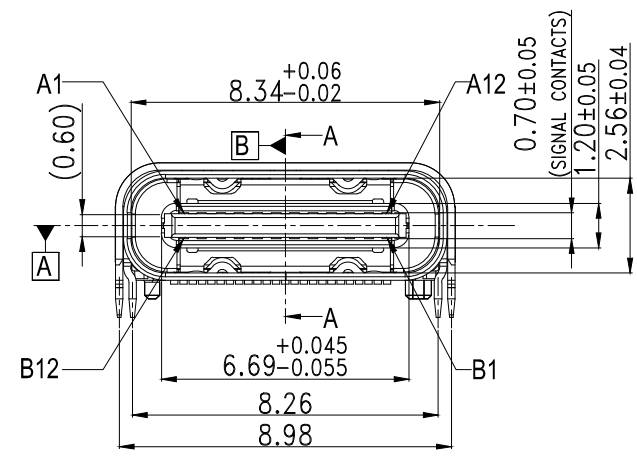

Notes:
 1,Material :
 Contacts : copper alloy
 Shell : Stainless steel.
 Housing : High-temperature polymer UL94V-0, black.
 2,Plating :
 Contacts:contact area 30u" Au, Solder tail gold flash or matte tin, nickel overall.
 Shell : Nickel Plating
 3.Coplanarity : 0.08Max.
 4.Packaging type: carrier tape.
 5.Material should be fulfilled Amphenol spec# SSN002
 AND Customer Requirements,for halogen free products,
 also need to meet SSN004

GENERAL	TOLERANCE	FILE.NO.	12401610	PART.NO.	12401610E4#2A	DRAWN	Allan.Lai	MATERIAL	SCALE	1:1	
x.±0.50	x. °± 5°	REV.	B	TITLE	USB TYPE C CONNECTOR	CHECKED	Weison.lu	DATE	09/06/18	UNIT	mm
.x±0.38	.x °± 2°	SIZE		SHEET	1 OF 2	APPROVED	Tom	Amphenol Shouhmin Industry			
.xx±0.25	.xx ± 1°	A4									

REV.	ECN.NO.	MODIFY.CONTENT	DATE
A		NEW RELEASE	04/28/17
B		Add NO PATTERN AREA	09/09/18

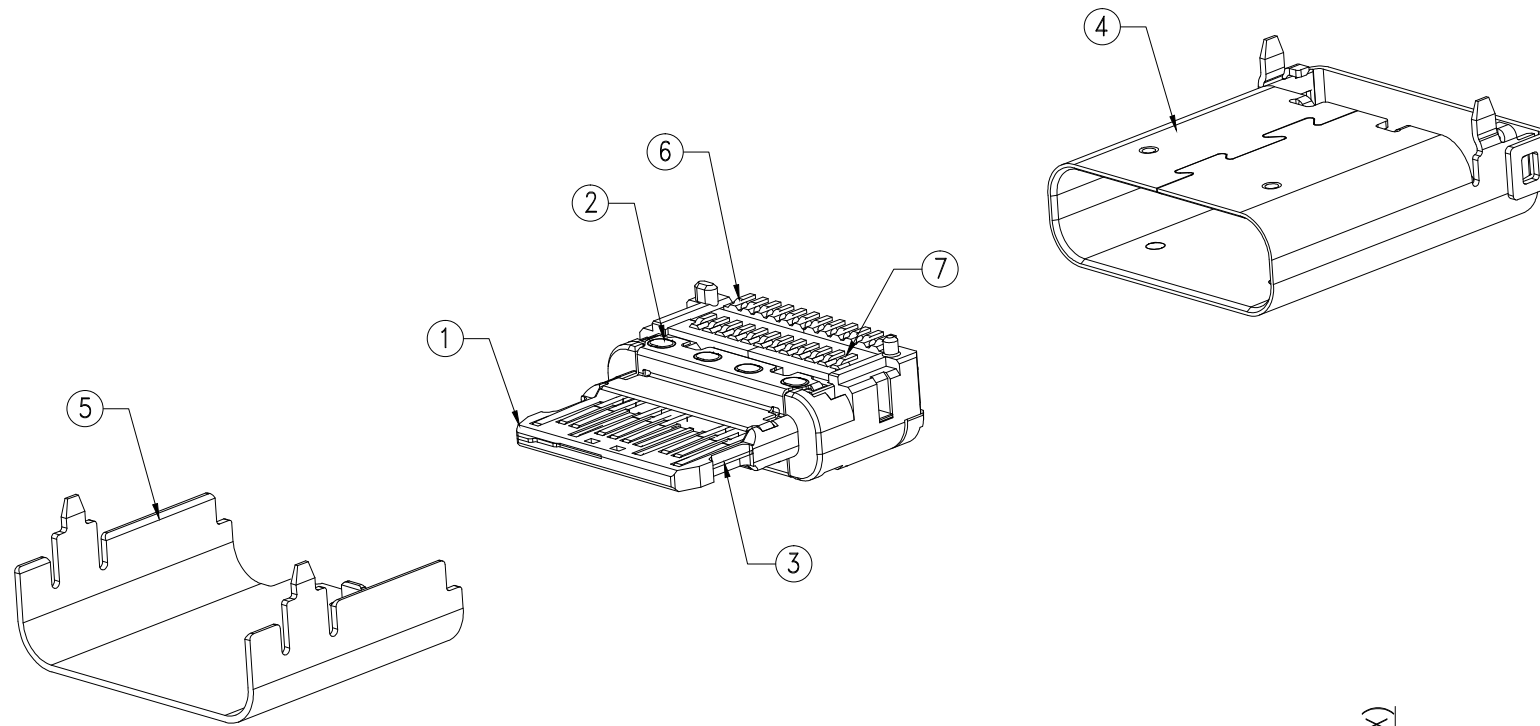

EXPLODE VIEW (SCALE N/A)

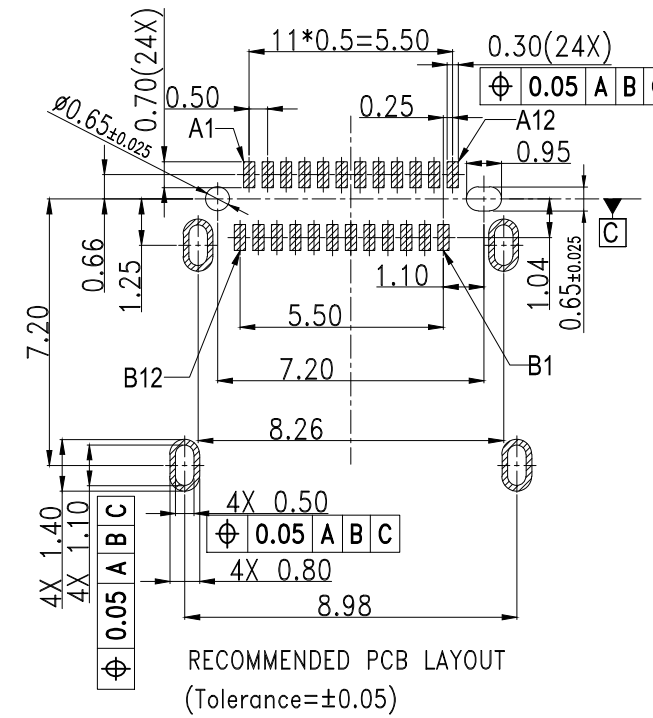

RECOMMENDED PCB LAYOUT
(Tolerance=±0.05)

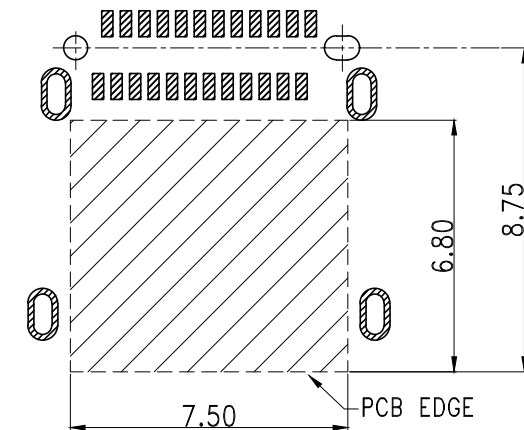

NO PATTERN AREA

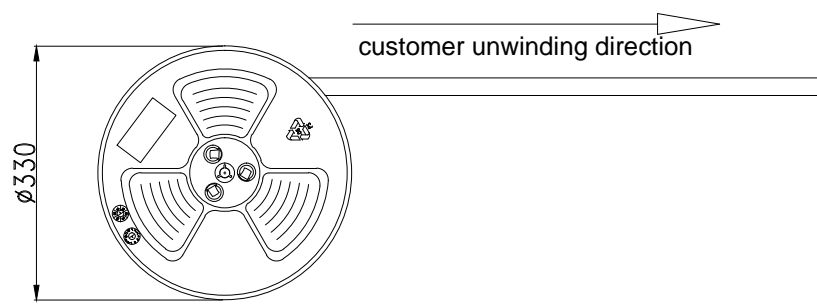
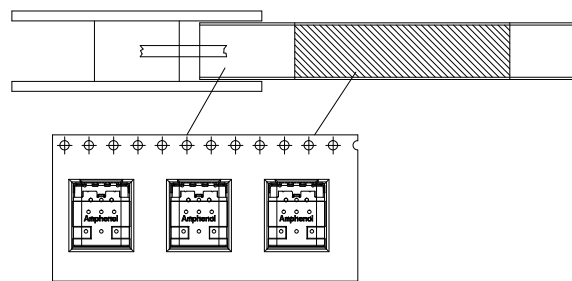

PACK DIRECTION

ITEM	DESCRIPTION	Q'TY	MATERIAL	FINISH
7	BOTTOM TERMINAL	1	Copper alloy	CONTACT:30u" AU MIN; SOLDER TAIL:100u" MATTE TIN MIN;
6	TOP TERMINAL	1	Copper alloy	CONTACT:30u" AU MIN; SOLDER TAIL:100u" MATTE TIN MIN;
5	OUTER SHELL	1	Stainless steel	SOLDER NICKEL: 50U" MIN
4	MAIN SHELL	1	Stainless steel	SOLDER NICKEL: 50U" MIN
3	GND SHEET	1	Stainless steel	SOLDER NICKEL: 50U" MIN
2	EMC	2	Stainless steel	SOLDER NICKEL: 50U" MIN
1	MAIN HOUSING	1	Nylon	BLACK

BILL OF MATERIAL

GENERAL	TOLERANCE	FILE.NO.	12401610	PART.NO.	12401610E4#2A	DRAWN	Allan.Lai
x.±0.50	x. °± 5°	REV.	B	TITLE	USB TYPE C CONNECTOR	CHECKED	Weison.lu
.x±0.38	.x °± 2°	SIZE		SHEET	2 OF 2	APPROVED	Tom
.xx±0.25	.xx ± 1°	A4					

MATERIAL	SCALE	1:1	
DATE	09/06/18	UNIT	mm
Amphenol Shouhmin Industry			