

Precision OPERATIONAL AMPLIFIER

DESCRIPTION

The OPA177 precision bipolar op amp feature very low offset voltage and drift. Laser-trimmed offset, drift and input bias current virtually eliminate the need for costly external trimming. The high performance and low cost make them ideally suited to a wide range of precision instrumentation.

The low quiescent current of the OPA177 dramatically reduce warm-up drift and errors due to thermoelectric effects in input interconnections. It provides an effective alternative to chopper-stabilized amplifiers. The low noise of the OPA177 maintains accuracy. OPA177 performance gradeouts are available. Packaging options include 8-pin plastic DIP and SOP-8 surface-mount packages.

FEATURES

- LOW OFFSET VOLTAGE: 25 μ V max
- LOW DRIFT: 0.3 μ V/ $^{\circ}$ C
- HIGH OPEN-LOOP GAIN: 130dB min
- LOW QUIESCENT CURRENT: 1.5mA typ
- REPLACES INDUSTRY-STANDARD OPAMPS: OP-07, OP-77, OP-177, AD707, ETC

APPLICATIONS

- PRECISION INSTRUMENTATION
- DATA ACQUISITION
- TEST EQUIPMENT
- BRIDGE AMPLIFIER
- THERMOCOUPLE AMPLIFIER

ORDERING INFORMATION

DEVICE	Package Type	MARKING	Packing	Packing Qty
OPA177N	DIP8	OPA177	TUBE	2000pcs/box
OPA177M/TR	SOP8	OPA177	REEL	2500pcs/reel
OPA177MM/TR	MSOP8	OPA177	REEL	3000pcs/reel
OPA177GN	DIP8	OPA177G	TUBE	2000pcs/box
OPA177GM/TR	SOP8	OPA177G	REEL	2500pcs/reel
OPA177GMM/TR	MSOP8	OPA177G	REEL	3000pcs/reel

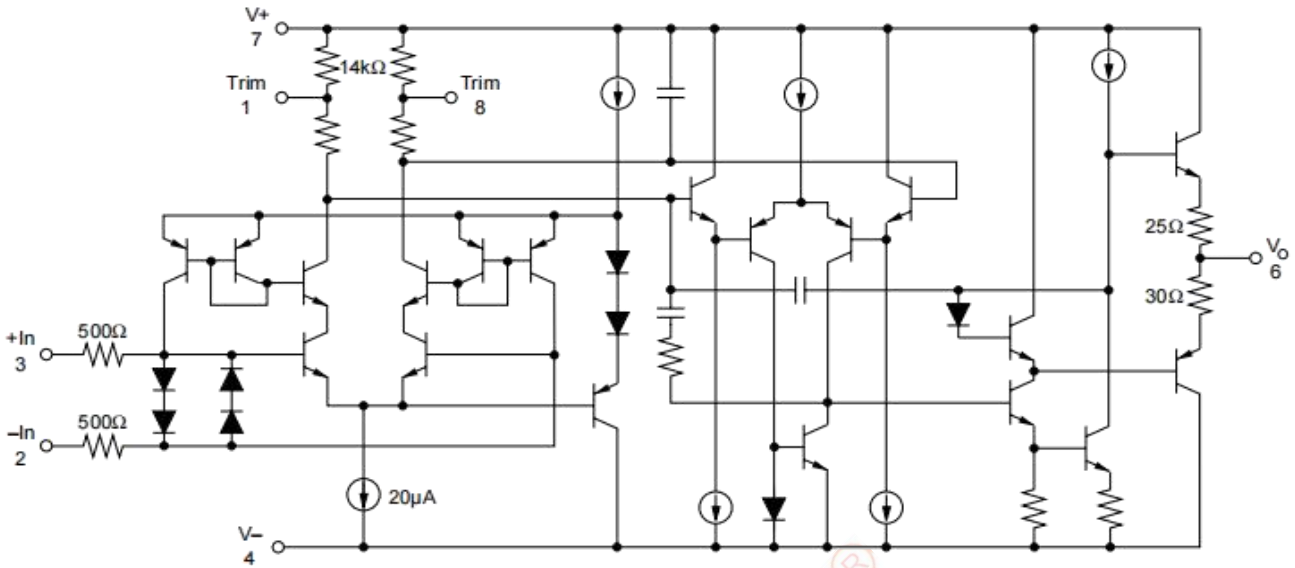

OPA177 SPECIFICATIONS

At $V_S = \pm 15V$, $T_A = +25^\circ C$, unless otherwise noted.

PARAMETER	CONDITION	OPA177G			OPA177			UNITS
		MIN	TYP	MAX	MIN	TYP	MAX	
OFFSET VOLTAGE								
Input Offset Voltage			10	25		20	60	μV
Long-Term Input Offset(1)			0.3			0.4		$\mu V/Mo$
Voltage Stability								
Offset Adjustment Range	$R_P = 20k$		± 3			*		mV
Power Supply Rejection Ratio	$V_S = \pm 3V$ to $\pm 18V$	115	125		110	120		dB
INPUT BIAS CURRENT								
Input Offset Current			0.3	1.5		*	2.8	nA
Input Bias Current			0.5	± 2		*	2.8	nA
NOISE								
Input Noise Voltage	1Hz to 100Hz(2)		85	150		*		nVrms
Input Noise Current	1Hz to 100Hz		4.5			*	*	pArms
INPUT IMPEDANCE								
Input Resistance	Differential Mode(3)	26	45		18.5	*		M Ω
	Common-Mode		200			*		G Ω
INPUT VOLTAGE RANGE								
Common-Mode Input Range(4)		± 13	± 14		*	*		V
Common-Mode Rejection	$V_{CM} = \pm 13V$	130	140		115	*		dB
OPEN-LOOP GAIN	$R_L \geq 2k\Omega$							
Large Signal Voltage Gain	$V_O = \pm 10V$ (5)	5110	12,000		200	6000		V/mV
OUTPUT								
Output Voltage Swing	$R_L \geq 10k\Omega$	± 13.5	± 14		*	*		V
	$R_L \geq 2k\Omega$	± 12.5	± 13		*	*		V
	$R_L \geq 1k\Omega$	± 12	± 12.5		*	*		V
Open-Loop Output Resistance			60			*		Ω

FREQUENCY RESPONSE								
Slew Rate	$R_L \geq 2k\Omega$	0.1	0.3		*	*		V/ μ s
Closed-Loop Bandwidth	G=+1	0.4	0.6		*	*		MHz
POWER SUPPLY								
Power Consumption	$V_S = \pm 15V$, No Load		40	60		*	*	mW
	$V_S = \pm 3V$, No Load		3.5	4.5		*	*	mW
Supply Current	$V_S = \pm 15V$, No Load		1.3	2		*	*	mW

At $V_S = \pm 15V$, $-40^\circ C \leq T_A \leq +85^\circ C$, unless otherwise noted.

OFFSET VOLTAGE								
Input Offset Voltage			15	40		20	100	μ V
Average Input Offset Voltage Drift			0.1	0.3		0.7	1.2	μ V/ $^\circ$ C
Power Supply Rejection Ratio	$V_S = \pm 3$ to $\pm 18V$	110	120		106	115		dB
INPUT BIAS CURRENT								
Input Offset Current			0.5	2.2		*	4.5	nA
Average Input Offset Current Drift(6)			1.5	40		*	85	Pa/ $^\circ$ C
Input Bias Current			0.5	± 4		*	± 6	nA
Average Input Bias Current Drift(6)			8	40		15	60	Pa/ $^\circ$ C
INPUT VOLTAGE RANGE								
Common-Mode Input Range		± 13	± 13.5		*	*		V
Common-Mode Rejection	$V_{CM} = \pm 13V$	120	140		110	*		dB
OPEN-LOOP GAIN								
Large Signal Voltage Gain	$R_L \geq 2k\Omega, V_O = \pm 10V$	2000	6000		1000	4000		V/mV
OUTPUT								
Output Voltage Swing	$R_L \geq 2k\Omega$	± 12	± 13		*	*		V
POWER SUPPLY								
Power Consumption	$V_S = \pm 15V$, No Load		60	75		*	*	mW
Supply Current	$V_S = \pm 15V$, No Load		2	25		*	*	mA

*Same as specification for product to left.

NOTES:

- (1) Long-Term Input Offset Voltage Stability refers to the averaged trend line of VOS vs time over extended periods after the first 30 days of operation. Excluding the initial hour of operation, changes in VOS during the first 30 operating days are typically less than 2 μ V.
- (2) Sample tested.
- (3) Guaranteed by design.
- (4) Guaranteed by CMRR test condition.
- (5) To insure high open-loop gain throughout the $\pm 10V$ output range, AOL is tested at $-10V \leq V_O \leq 0V$, $0V \leq V_O \leq +10V$, and $-10V \leq V_O \leq +10V$.
- (6) Guaranteed by end-point limits.

PIN CONFIGURATION

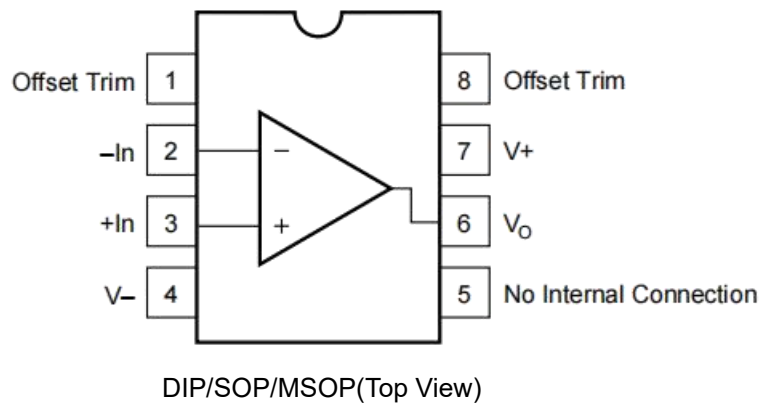

ABSOLUTE MAXIMUM RATINGS

Condition		Min	Max
Power Supply Voltage		-22V	+22V
Differential Input Voltage		-30V	+30V
Input Voltage		-VS	+VS
Output Short Circuit		Continuous	
Operating Temperature	Plastic DIP8, SOP8	-40°C	+85°C
	$\theta_{JA}(DIP)$	-	100°C/W
	$\theta_{JA}SOP$	-	160°C/W
Storage Temperature	Plastic DIP8, SOP8	-65°C	+125°C
Junction Temperature		-	+150°C
Lead Temperature (soldering, 10s) N packages		-	+300°C
(soldering, 3s) M package		-	+260°C



ELECTROSTATIC DISCHARGE SENSITIVITY

Any integrated circuit can be damaged by ESD. Burr-Brown recommends that all integrated circuits be handled with appropriate precautions. ESD can cause damage ranging from subtle performance degradation to complete device failure. Precision integrated circuits may be more susceptible to damage because very small parametric changes could cause the device not to meet published specifications.

Burr-Brown's standard ESD test method consists of five 1000V positive and negative discharges (100pF in series with 1.5kΩ) applied to each pin. Failure to observe proper handling procedures could result in small changes to the OPA177's input bias current.

TYPICAL PERFORMANCE CURVES

At $T_A = +25^\circ\text{C}$, $V_S = \pm 15\text{V}$, unless otherwise noted.

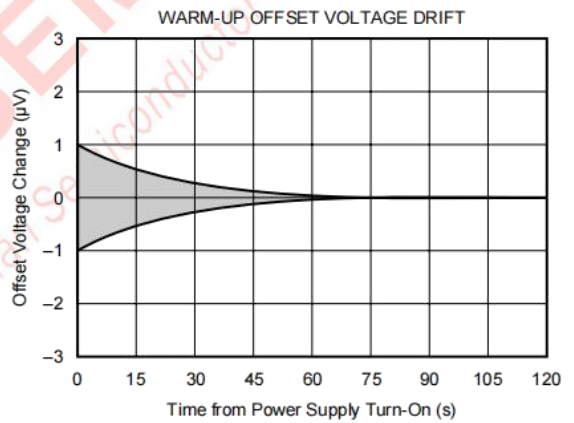
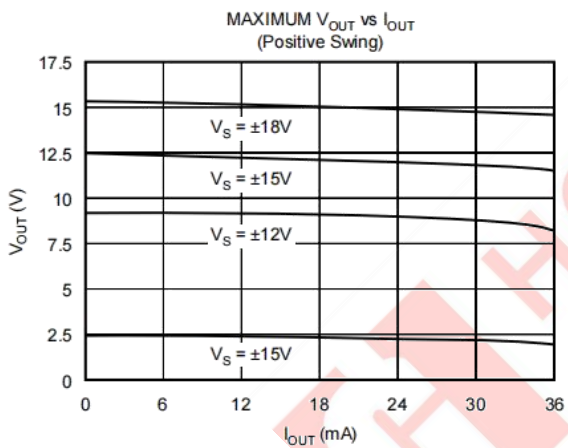
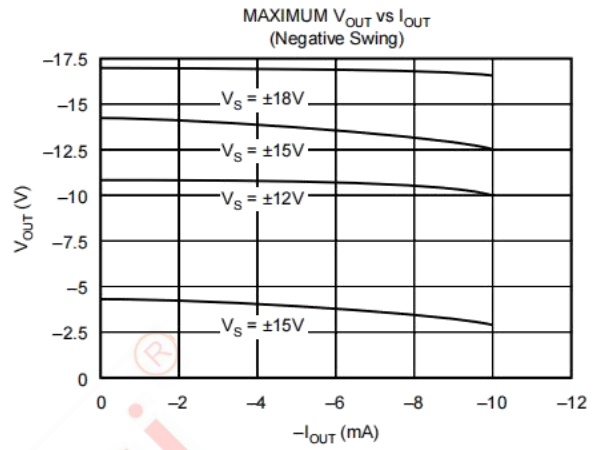
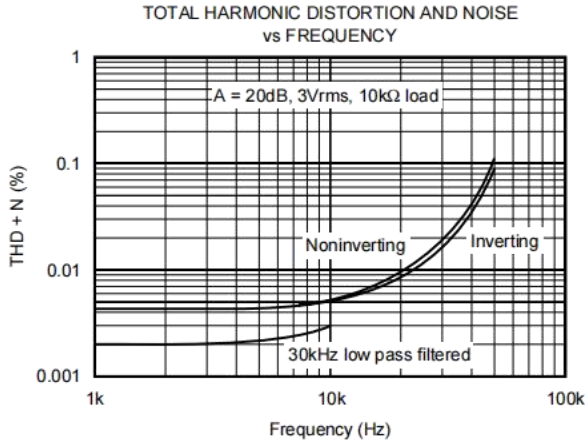

TYPICAL PERFORMANCE CURVES(CONT)

At $T_A = +25^\circ\text{C}$, $V_S = \pm 15\text{V}$, unless otherwise noted.

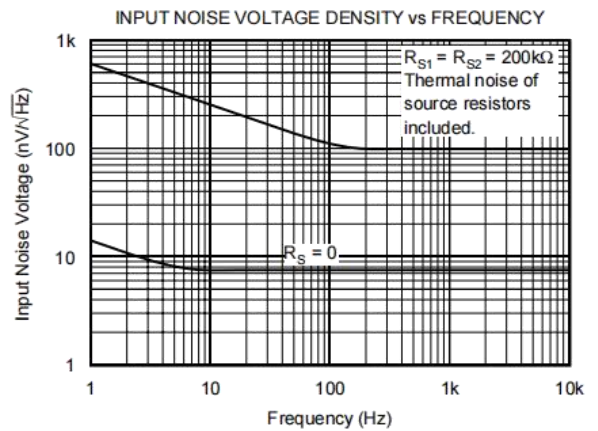
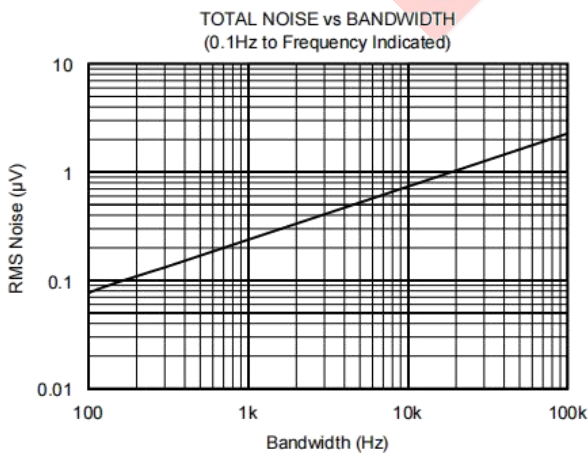
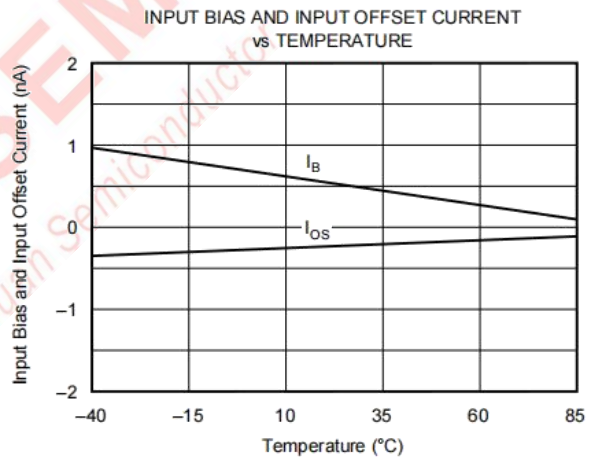
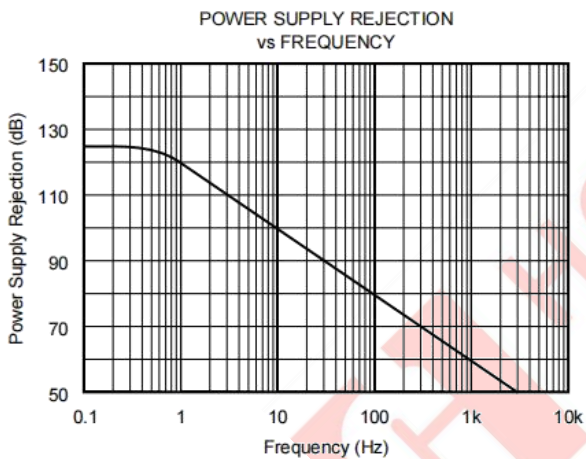
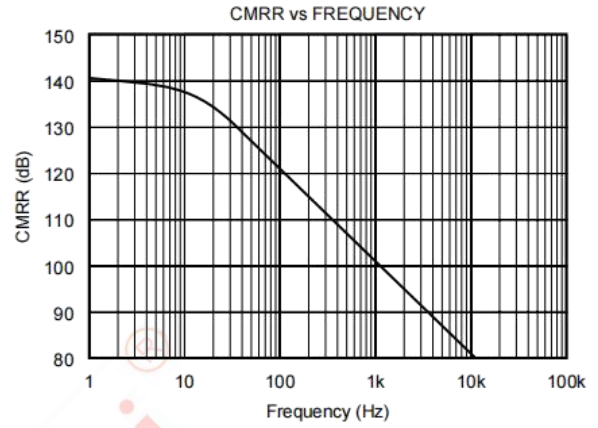
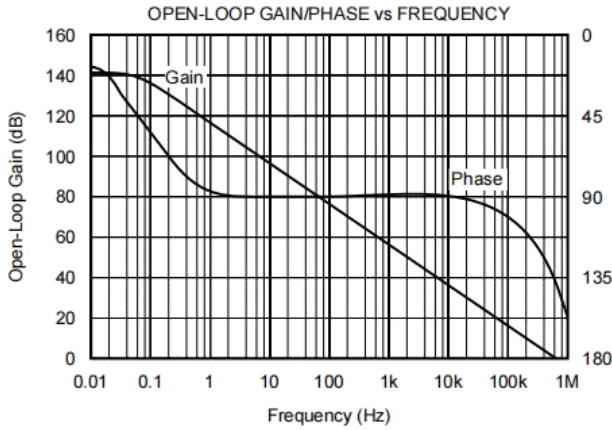

TYPICAL PERFORMANCE CURVES(CONT)

At $T_A = +25^\circ\text{C}$, $V_S = \pm 15\text{V}$, unless otherwise noted.

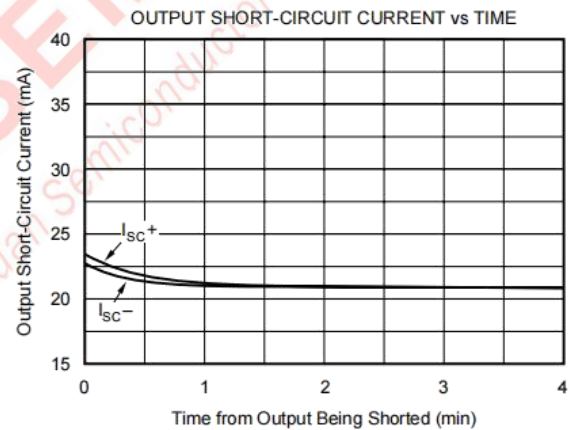
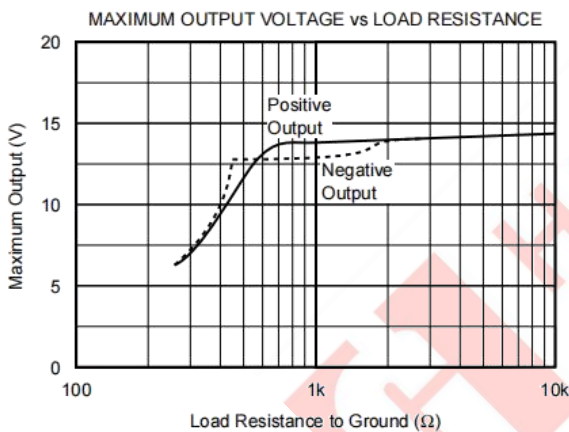
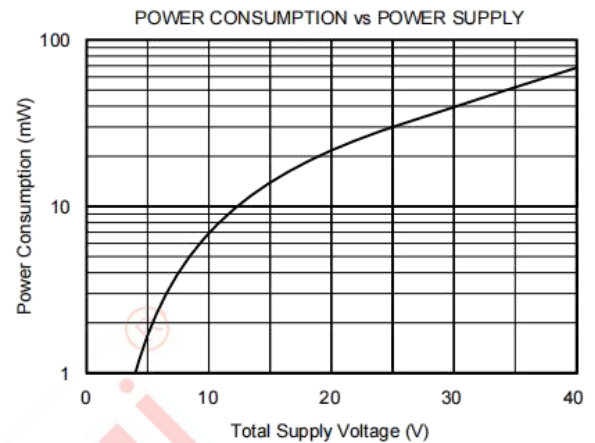
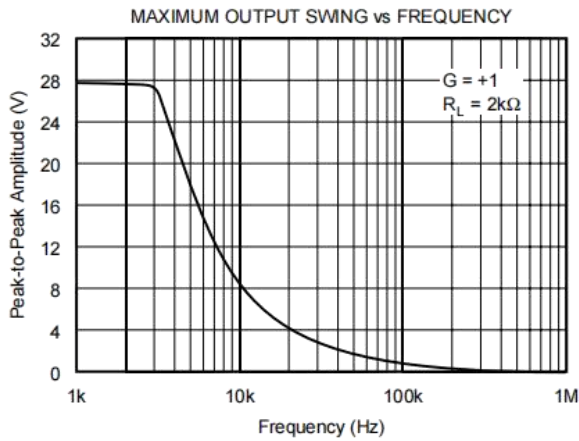

APPLICATIONS INFORMATION

The OPA177 is unity-gain stable, making it easy to use and free from oscillations in the widest range of circuitry. Applications with noisy or high impedance power supply lines may require decoupling capacitors close to the device pins. In most cases $0.1\mu\text{F}$ ceramic capacitors are adequate.

The OPA177 has very low offset voltage and drift. To achieve highest performance, circuit layout and mechanical conditions must be optimized. Offset voltage and drift can be degraded by small thermoelectric potentials at the op amp inputs. Connections of dissimilar metals will generate thermal potential which can mask the ultimate performance of the OPA177. These thermal potentials can be made to cancel by assuring that they are equal in both input terminals

1. Keep connections made to the two input terminals close together.
2. Locate heat sources as far as possible from the critical input circuitry.
3. Shield the op amp and input circuitry from air currents such as cooling fans.

OFFSET VOLTAGE ADJUSTMENT

The OPA177 has been laser-trimmed for low offset voltage and drift so most circuits will not require external adjustment. Figure 1 shows the optional connection of an external potentiometer to adjust offset voltage. This adjustment should not be used to compensate for offsets created elsewhere in a system since this can introduce excessive temperature drift.

INPUT PROTECTION

The inputs of the OPA177 are protected with 500Ω series input resistors and diode clamps as shown in the simplified circuit diagram. The inputs can withstand ±30V differential inputs without damage. The protection diodes will, of course, conduct current when the inputs are overdriven. This may disturb the slewing behavior of unity-gain follower applications, but will not damage the op amp.

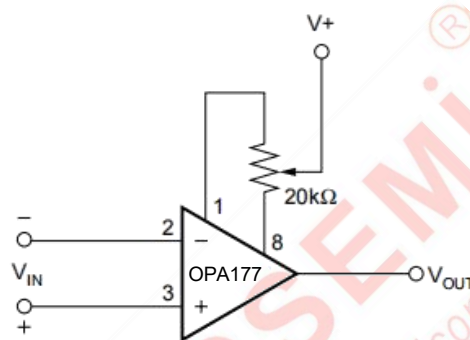

Trim Range is approximately ±3.0mV

NOISE PERFORMANCE

The noise performance of the OPA177 is optimized for circuit impedances in the range of 2kΩ to 50kΩ. Total noise in an application is a combination of the op amp's input voltage noise and input bias current noise reacting with circuit impedances. For applications with higher source impedance, the OPA627 FET-input op amp will generally provide lower noise. For very low impedance applications, the OPA27 will provide lower noise.

INPUT BIAS CURRENT CANCELLATION

The input stage base current of the OPA177 is internally compensated with an equal and opposite cancellation current. The resulting input bias current is the difference between the input stage base current and the cancellation current. This residual input bias current can be positive or negative.

When the bias current is cancelled in this manner, the input bias current and input offset current are approximately the same magnitude. As a result, it is not necessary to balance the DC resistance seen at the two input terminals (Figure 2). A resistor added to balance the input resistances may actually increase offset and noise.

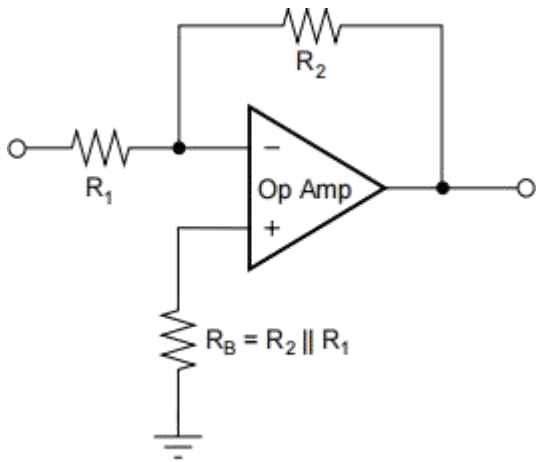

(a)

Conventional op amp with external bias current cancellation resistor

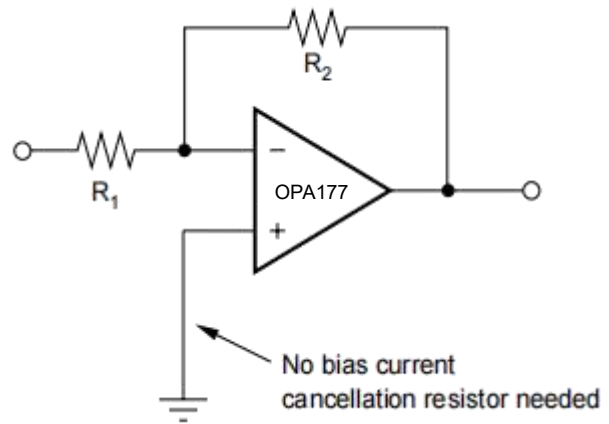

(b)

OPA177 with no external bias current cancellation resistor.

FIGURE 2. Input Bias Current Cancellation.

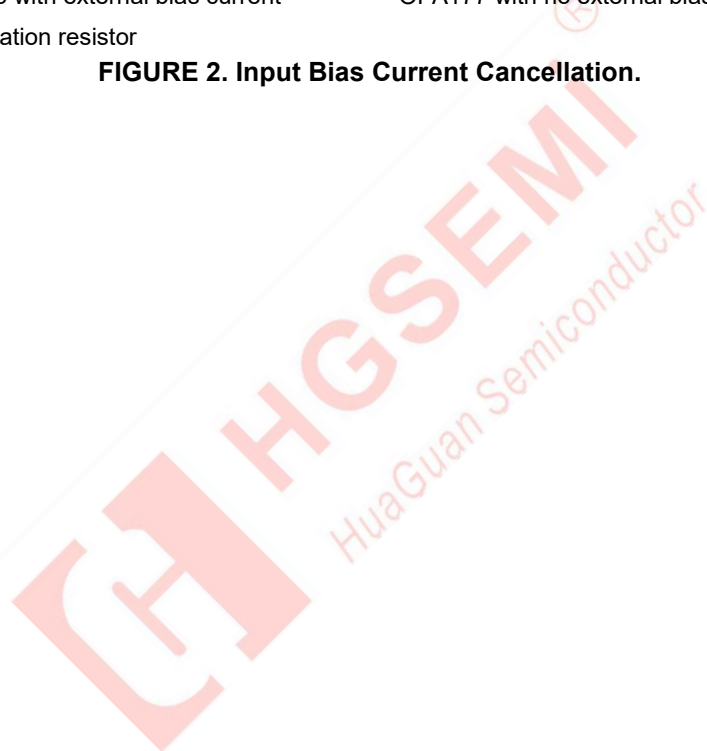

Physical Dimensions

DIP8

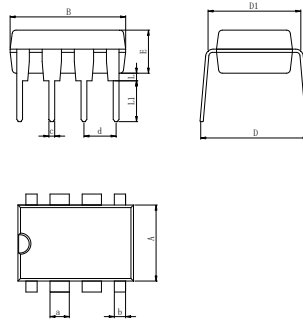
Dimensions In Millimeters(DIP8)

Symbol:	A	B	D	D1	E	L	L1	a	b	c	d
Min:	6.10	9.00	8.40	7.42	3.10	0.50	3.00	1.50	0.85	0.40	2.54 BSC
Max:	6.68	9.50	9.00	7.82	3.55	0.70	3.60	1.55	0.90	0.50	

SOP8 (150mil)

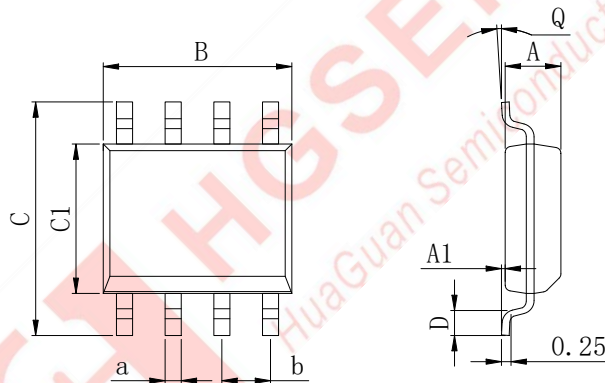

Dimensions In Millimeters(SOP8)

Symbol:	A	A1	B	C	C1	D	Q	a	b
Min:	1.35	0.05	4.90	5.80	3.80	0.40	0°	0.35	1.27 BSC
Max:	1.55	0.20	5.10	6.20	4.00	0.80	8°	0.45	

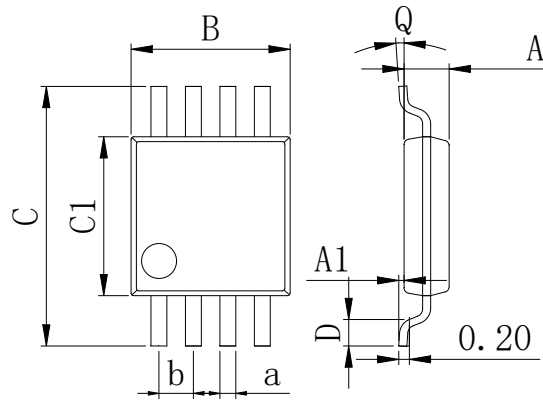
MSOP8

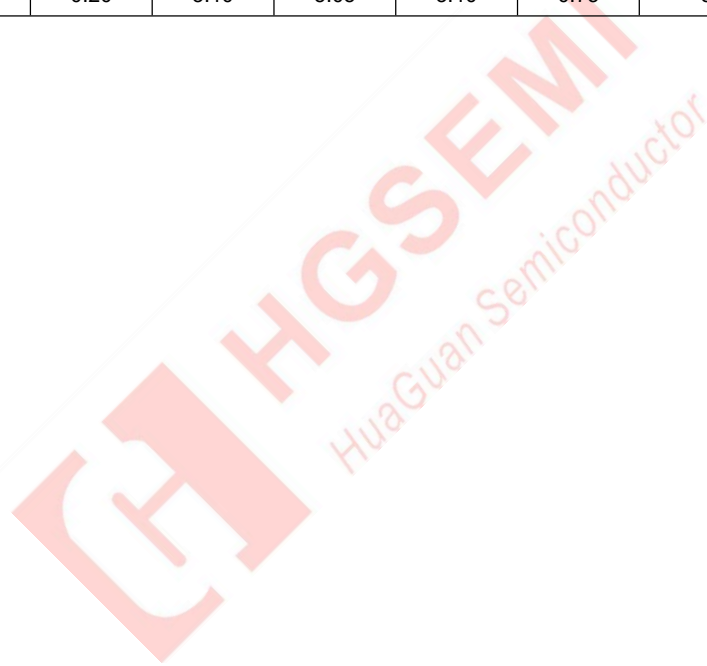

Dimensions In Millimeters(MSOP8)									
Symbol:	A	A1	B	C	C1	D	Q	a	b
Min:	0.80	0.05	2.90	4.75	2.90	0.35	0°	0.25	0.65 BSC
Max:	0.90	0.20	3.10	5.05	3.10	0.75	8°	0.35	



IMPORTANT STATEMENT:

Huaguan Semiconductor Co,Ltd. reserves the right to change the products and services provided without notice. Customers should obtain the latest relevant information before ordering, and verify the timeliness and accuracy of this information.

Customers are responsible for complying with safety standards and taking safety measures when using our products for system design and machine manufacturing to avoid potential risks that may result in personal injury or property damage.

Our products are not licensed for applications in life support, military, aerospace, etc., so we do not bear the onsequences of the application of these products in these fields.

Huaguan Semiconductor Co,Ltd. the performance of the semiconductor products produced by the company can reach the performance indicators that can be applied at the time of sales. The use of testing and other quality control technologies is limited to the quality assurance scope of Huaguan semiconductor. Not all parameters of each device need to be tested. The above documents are for reference only, and all are subject to the physical parameters.

Our documentation is only permitted to be copied without any tampering with the content, so we do not accept any responsibility or liability for the altered documents.