



# SKY67180-306LF: 1.5 to 3.8 GHz Two-Stage, High-Gain Low-Noise Amplifier

## Applications

- LTE, GSM, WCDMA, HSDPA macro-base and micro-base stations
- S and C band ultra-low-noise receivers
- Cellular repeaters, small-cell, macro-cell, DAS, and RRH/RRUs
- High-temperature applications to +105 °C

## Features

- Ultra-low reference design NF: 0.8 dB @ 3.5 GHz
- High gain: 31 dB (typical) @ 3.5 GHz
- Low quiescent current: 125 mA
- Stage 1 and 2 adjustable current
- Small QFN (16-pin, 4 x 4 mm) Pb-free package (MSL1, 260 °C per JEDEC J-STD-020)

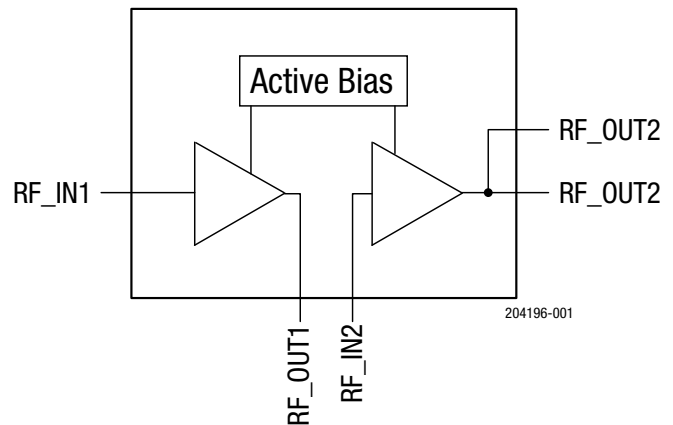

Figure 1. SKY67180-306LF Block Diagram

## Description

The SKY67180-306LF is a two-stage, low-noise amplifier (LNA) with active bias and high-linearity performance. The front end of the device provides an ultra-low noise figure (NF) while the output stage provides high gain, linearity, and efficiency.

With excellent thermal performance, the SKY67180-306LF is rated for operation up to +105 °C.

The SKY67180-306LF is provided in a 4 x 4 mm, 16-pin Quad Flat No-Lead (QFN) package. A functional block diagram is shown in Figure 1. The pin configuration is shown in Figure 2. Signal pin assignments and functional pin descriptions are provided in Table 1.



Skyworks Green™ products are compliant with all applicable legislation and are halogen-free. For additional information, refer to *Skyworks Definition of Green™*, document number SQ04-0074.

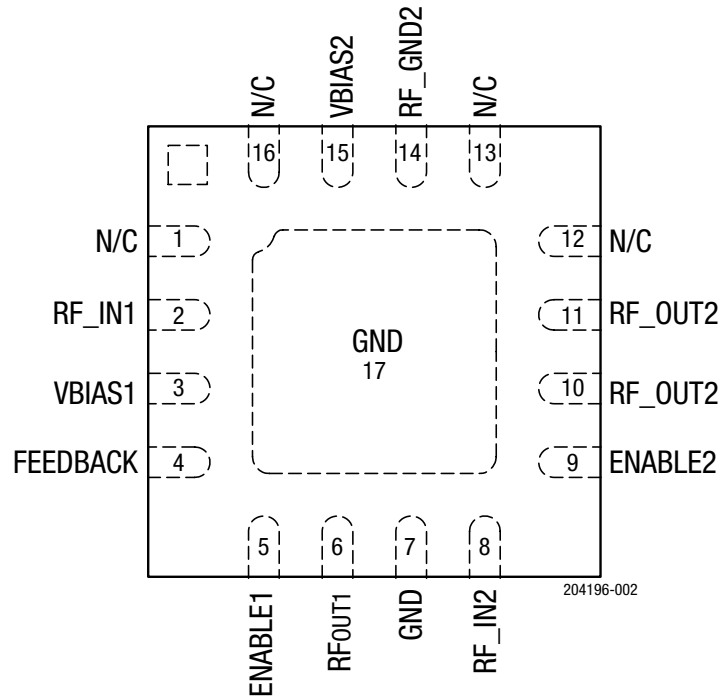

Figure 2. SKY67180-306LF Pinout (Top View)

Table 1. SKY67180-306LF Signal Descriptions

Pin	Name	Description	Pin	Name	Description
1	N/C	No connection. May be grounded with no change in performance.	10	RF_OUT2	RF output of second stage amplifier
2	RF_IN1	RF input to first stage LNA	11	RF_OUT2	RF output of second stage amplifier
3	RF_GND/VBIAS1	AC ground for first stage bias circuit and bias voltage input that sets the first stage bias current.	12	N/C	No connection. May be grounded with no change in performance.
4	FEEDBACK	Feedback pin. Leave open when not used. This feedback option is typically not used since it reduces gain.	13	N/C	No connection. May be grounded with no change in performance.
5	ENABLE1	First stage LNA Enable pin.	14	RF_GND2	AC ground for second stage bias circuit
6	RFOUT1	RF output of first stage LNA	15	VBIAS2	Bias voltage input that sets the second stage bias current
7	GND	Ground	16	N/C	No connection. May be grounded with no change in performance.
8	RF_IN2	RF input to second stage amplifier	17	GND	Center ground
9	ENABLE2	Second stage LNA Enable pin.			

## Electrical and Mechanical Specifications

The absolute maximum ratings of the SKY67180-306LF are provided in Table 2. Electrical specifications are provided in Tables 3 and 4. Typical performance characteristics are shown in Figures 3 through 10.

**Table 2. SKY67180-306LF Absolute Maximum Ratings<sup>1</sup>**

Parameter	Symbol	Minimum	Maximum	Units
Supply voltage	V <sub>DD</sub>		6.0	V
RF input power	P <sub>IN</sub>		+20	dBm
Operating temperature	T <sub>OP</sub>	-40	+105	°C
Storage temperature	T <sub>STG</sub>	-65	+125	°C
Junction temperature	T <sub>J</sub>		+150	°C
Thermal resistance: Stage 1 Stage 2	Θ <sub>JC</sub>		50 65	°C/W °C/W
Electrostatic discharge: Charged Device Model (CDM), Class 3 Human Body Model (HBM), Class 1A	ESD		1000 250	V V

1. Exposure to maximum rating conditions for extended periods may reduce device reliability. Exceeding any of the limits listed here may result in permanent damage to the device.

---

**ESD Handling:** Industry-standard ESD handling precautions must be adhered to at all times to avoid damage to this device.

---

**Table 3. SKY67180-306LF Electrical Specifications<sup>1</sup>**  
**VDD = +5 V, TOP = +25 °C, PIN = -30 dBm, Optimized for 3.4 to 3.6 GHz Operation, Unless Otherwise Noted**

Parameter	Symbol	Test Condition	Min	Typ	Max	Units
Noise figure <sup>2</sup>	NF	@ 3500 MHz		0.8	1.1	dB
Small signal gain	S21	@ 3500 MHz	28	31		dB
Input return loss	S11	@ 3500 MHz		9.5		dB
Output return loss	S22	@ 3500 MHz		15		dB
Reverse isolation	S12	@ 3500 MHz		49		dB
Input third order intercept point	IIP3	@ 3500 MHz, Δf = 1 MHz, PIN = -30 dBm/tone	-1	+3		dBm
Output third order intercept point	OIP3	@ 3500 MHz, Δf = 1 MHz, PIN = -30 dBm/tone	+30	+34		dBm
Output 1 dB compression point	OP1dB	@ 3500 MHz	13	17		dBm
Supply voltage	VDD			5		V
Enable voltage: Gain mode Power-down mode	VENABLE		0 1.5		0.2 5.5	V V
Quiescent supply current	IDD	Set with external resistor Stage 1 Rbias = 18 kΩ Stage 2 Rbias = 7.5 kΩ	100	125		mA

1. Performance is assured only under the conditions listed in this Table and is not invariant over the full operating or storage temperature ranges. Operation at elevated temperatures may reduce reliability of the device.
2. Noise figure has been de-embedded as 0.1 dB @ 3.5 GHz for connector and board loss.

**Table 4. SKY67180-306LF Electrical Specifications<sup>1, 2</sup>**  
**VDD = +5 V, TOP = +25 °C, PIN = -30 dBm, Optimized for 2.6 GHz Operation, Unless Otherwise Noted**

Parameter	Symbol	Test Condition	Min	Typ	Max	Units
Noise figure <sup>3</sup>	NF	@ 2.6 GHz		0.7		dB
Small signal gain	S21	@ 2.6 GHz		34.17		dB
Input return loss	S11	@ 2.6 GHz		17.3		dB
Output return loss	S22	@ 2.6 GHz		14.6		dB
Reverse isolation	S12	@ 2.6 GHz		50.04		dB
Input third order intercept point	IIP3	@ 2.6 GHz, Δf = 1 MHz, PIN = -30 dBm/tone		+4.22		dBm
Output third order intercept point	OIP3	@ 2.6 GHz, Δf = 1 MHz, PIN = -30 dBm/tone		+38.76		dBm

1. Performance is assured only under the conditions listed in this Table and is not invariant over the full operating or storage temperature ranges. Operation at elevated temperatures may reduce reliability of the device.
2. Tested using the Evaluation Board BOM listed in Table 8.
3. Noise figure has been de-embedded as 0.1 dB @ 2.6 GHz for connector and board loss.

**Table 5. SKY67180-306LF Electrical Specifications<sup>1, 2</sup>**  
**VDD = +5 V, TOP = +25 °C, PIN = -30 dBm, Optimized for 1.7 to 2.7 GHz Operation, Unless Otherwise Noted**

Parameter	Symbol	Test Condition	Min	Typ	Max	Units
Noise figure <sup>3</sup>	NF	@ 1700 MHz @ 2200 MHz @ 2700 MHz		0.45 0.54 0.74		dB
Small signal gain	S <sub>21</sub>	@ 1700 MHz @ 2200 MHz @ 2700 MHz		39.7 34.4 31.8		dB
Input return loss	S <sub>11</sub>	@ 1700 MHz @ 2200 MHz @ 2700 MHz		4.6 12.1 12.7		dB
Output return loss	S <sub>22</sub>	@ 1700 MHz @ 2200 MHz @ 2700 MHz		13 19.4 7.5		dB
Reverse isolation	S <sub>12</sub>	@ 1700 MHz @ 2200 MHz @ 2700 MHz		58 55.2 56.2		dB
Input third order intercept point	IIP3	Δf = 1 MHz, PIN = -30 dBm/tone @ 1700 MHz @ 2200 MHz @ 2700 MHz		-5.3 1.3 5.6		dBm
Output third order intercept point	OIP3	Δf = 1 MHz, PIN = -30 dBm/tone @ 1700 MHz @ 2200 MHz @ 2700 MHz		34.6 37.4 37.6		dBm
Input 1 dB compression point	IP1dB	@ 1700 MHz @ 2200 MHz @ 2700 MHz		-17.6 -13.0 -10.2		dBm
Output 1 dB compression point	OP1dB	@ 1700 MHz @ 2200 MHz @ 2700 MHz		21.1 20.8 20.6		dBm
Supply voltage	V <sub>DD</sub>			5		V
Enable voltage: Gain mode Power-down mode	V <sub>ENABLE</sub>		0 1.5		0.2 5.5	V V
Quiescent supply current	I <sub>DD</sub>	Set with external resistor Stage 1 R <sub>bias</sub> = 11 kΩ Stage 2 R <sub>bias</sub> = 11 kΩ		125		mA

1. Performance is assured only under the conditions listed in this Table and is not invariant over the full operating or storage temperature ranges. Operation at elevated temperatures may reduce reliability of the device.
2. Tested using the Evaluation Board BOM listed in Table 9.
3. Noise figure has been de-embedded as 0.1 dB @ 1.7 to 2.7 GHz for connector and board loss.

**Table 6. SKY67180-306LF Electrical Specifications<sup>1, 2</sup>**  
**VDD = +5 V, TOP = +25 °C, PIN = -30 dBm, Optimized for 1.92 to 1.98 GHz Operation, Unless Otherwise Noted**

Parameter	Symbol	Test Condition	Min	Typ	Max	Units
Noise figure <sup>3</sup>	NF	@ 1920 MHz @ 1950 MHz @ 1980 MHz		0.37 0.38 0.35		dB
Small signal gain	S21	@ 1920 MHz @ 1950 MHz @ 1980 MHz		38.3 37.9 37.5		dB
Input return loss	S11	@ 1920 MHz @ 1950 MHz @ 1980 MHz		9.5 10.5 11.4		dB
Output return loss	S22	@ 1920 MHz @ 1950 MHz @ 1980 MHz		27.8 22.9 21.5		dB
Reverse isolation	S12	@ 1920 MHz @ 1950 MHz @ 1980 MHz		53.5 54.3 53.9		dB
Input third order intercept point	IIP3	$\Delta f = 1 \text{ MHz}$ , PIN = -30 dBm/tone @ 1920 MHz @ 1950 MHz @ 1980 MHz		-3.7 -3.4 -2.8		dBm
Output third order intercept point	OIP3	$\Delta f = 1 \text{ MHz}$ , PIN = -30 dBm/tone @ 1920 MHz @ 1950 MHz @ 1980 MHz		34.6 34.7 34.7		dBm
Input 1 dB compression point	IP1dB	@ 1920 MHz @ 1950 MHz @ 1980 MHz		-16.2 -15.9 -15.5		dBm
Output 1 dB compression point	OP1dB	@ 1920 MHz @ 1950 MHz @ 1980 MHz		21.2 21.2 21.1		dBm
Supply voltage	V <sub>DD</sub>			5		V
Enable voltage: Gain mode Power-down mode	V <sub>ENABLE</sub>		0 1.5		0.2 5.5	V V
Quiescent supply current	I <sub>DD</sub>	Set with external resistor Stage 1 Rbias = 11 k $\Omega$ Stage 2 Rbias = 11 k $\Omega$		125		mA

1. Performance is assured only under the conditions listed in this Table and is not invariant over the full operating or storage temperature ranges. Operation at elevated temperatures may reduce reliability of the device.
2. Tested using the Evaluation Board BOM listed in Table 9.
3. Noise figure has been de-embedded as 0.1 dB @ 1.92 to 1.98 GHz for connector and board loss.

### Typical Performance Characteristics

VDD = +5 V, TOP = +25 °C, PIN = -30 dBm, Optimized for 3.4 to 3.6 GHz Operation, Unless Otherwise Noted

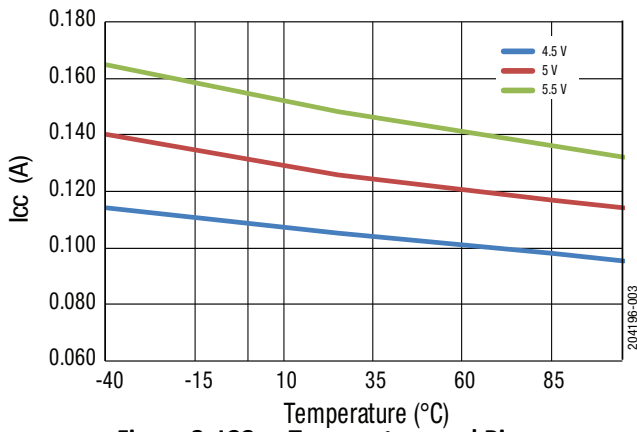

Figure 3. ICC vs Temperature and Bias

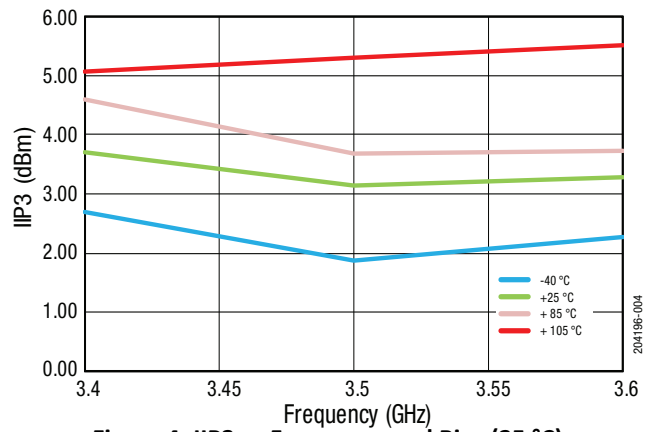

Figure 4. IIP3 vs Frequency and Bias (25 °C)

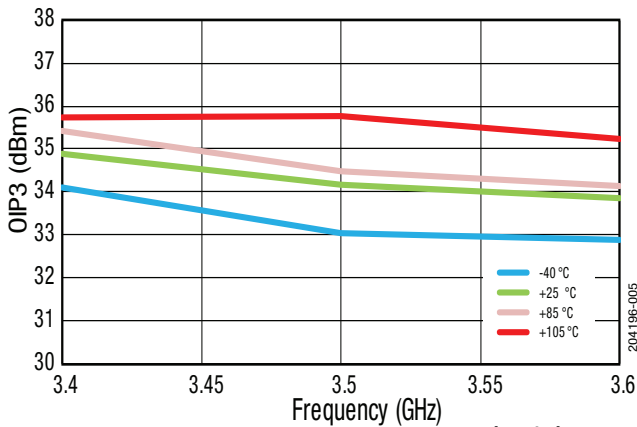

Figure 5. OIP3 vs Frequency and Bias (25 °C)

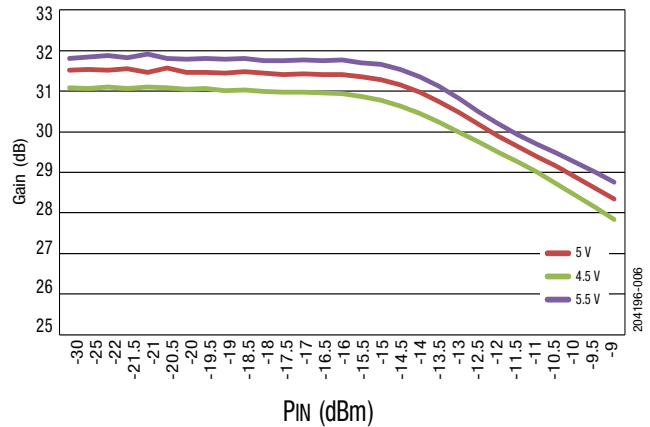

Figure 6. 3.4 GHz, IP1dB over Bias

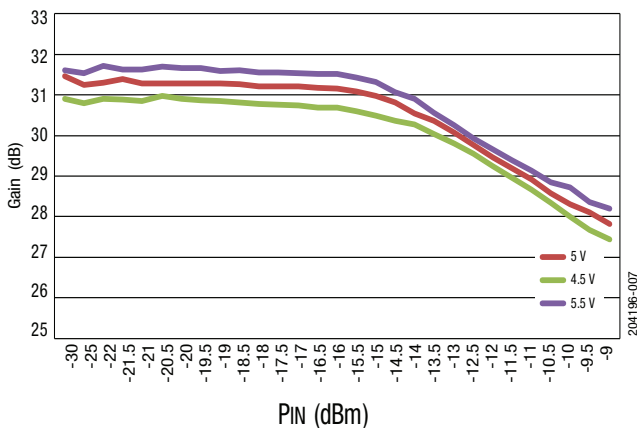

Figure 7. 3.5 GHz, IP1dB over Bias

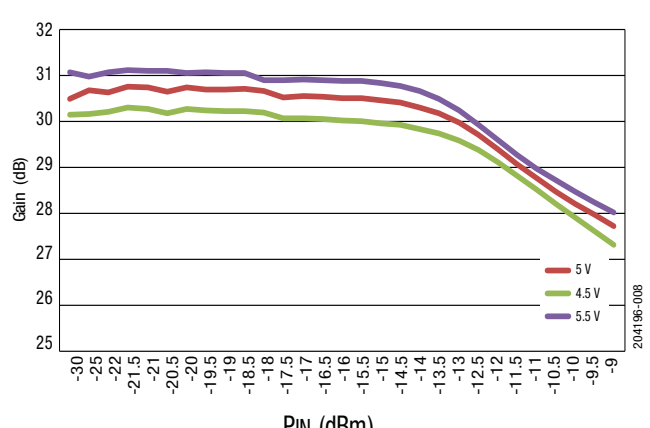

Figure 8. 3.6 GHz, IP1dB over Bias

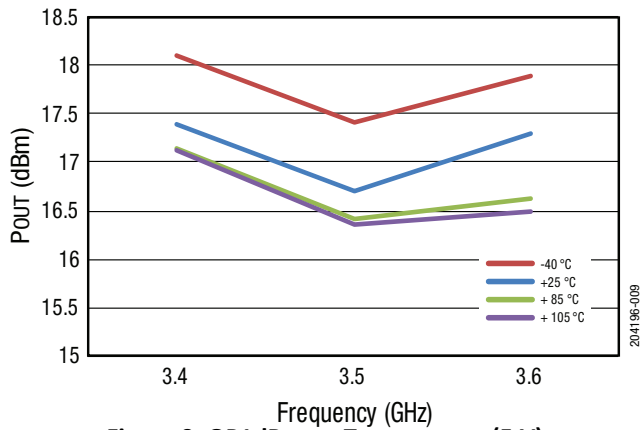

Figure 9. OP1dB over Temperature (5 V)

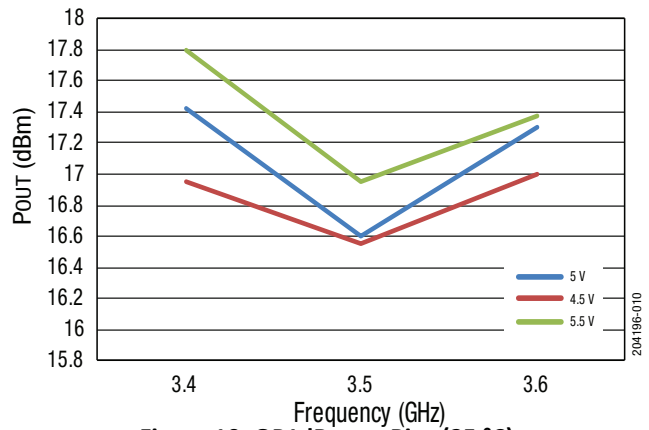

Figure 10. OP1dB over Bias (25 °C)

### Typical Performance Characteristics

1500 to 2700 MHz, VDD = +5 V, PIN = -30 dBm, Optimized for 1.7 to 2.7 GHz Operation, Unless Otherwise Noted

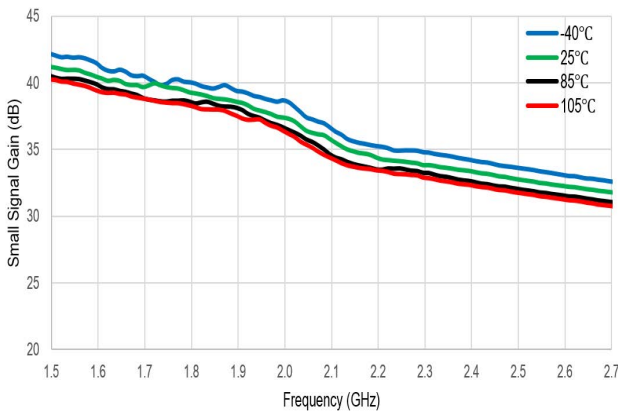

Figure 11. Small Signal Gain (dB) vs Frequency (GHz)

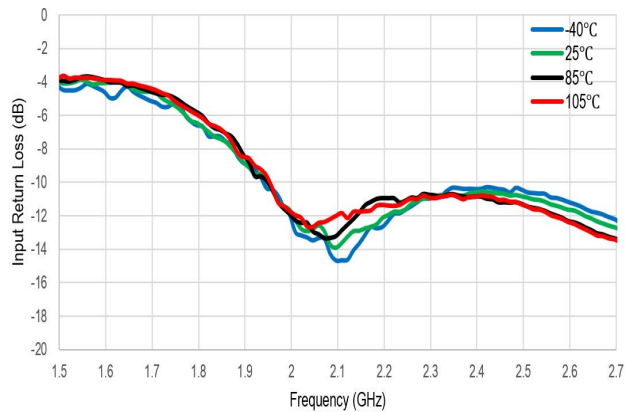

Figure 12. Input Return Loss (dB) vs Frequency (GHz)

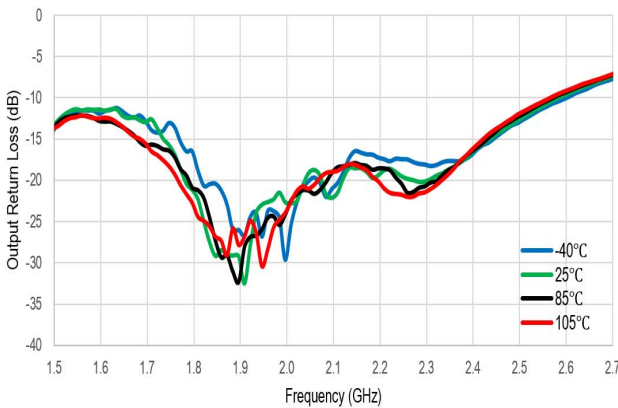

Figure 13. Output Return Loss (dB) vs Frequency (GHz)

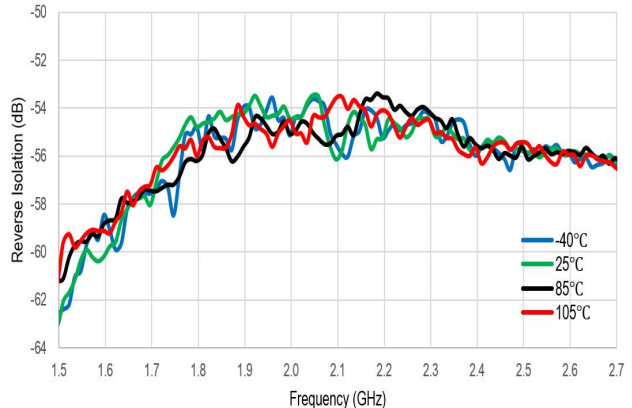

Figure 14. Reverse Isolation (dB) vs Frequency (GHz)



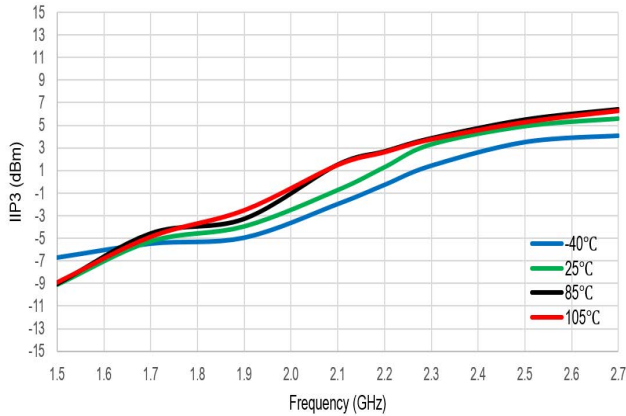

Figure 15. IIP3 (dBm) vs Frequency (GHz)

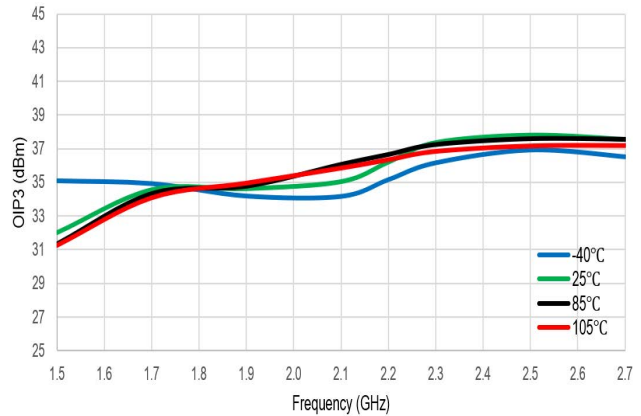

Figure 16. OIP3 (dBm) vs Frequency (GHz)

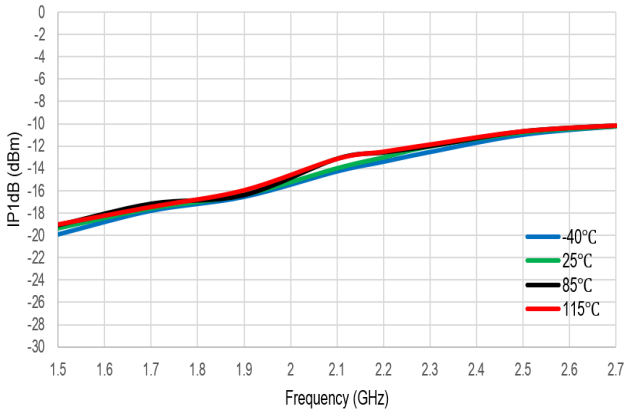

Figure 17. IP1dB (dBm) vs Frequency (GHz)

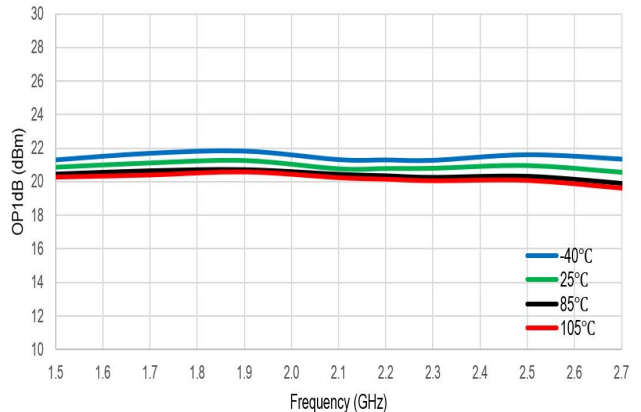

Figure 18. OP1dB (dBm) vs Frequency (GHz)

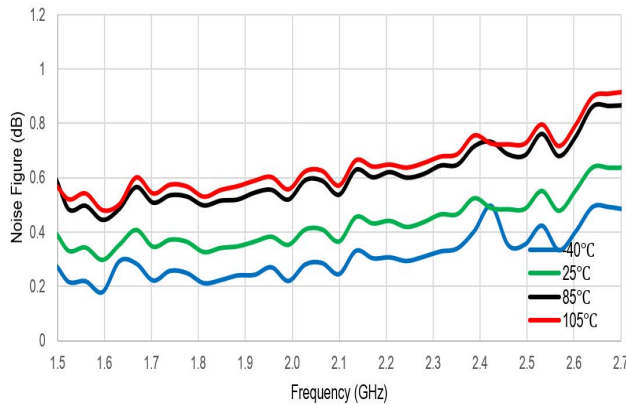

Figure 19. Noise Figure (dB) vs Frequency (GHz)

### Typical Performance Characteristics

1920 to 1980 MHz, VDD = +5 V, PIN = -30 dBm, Optimized for 1.7 to 2.7 GHz Operation, Unless Otherwise Noted

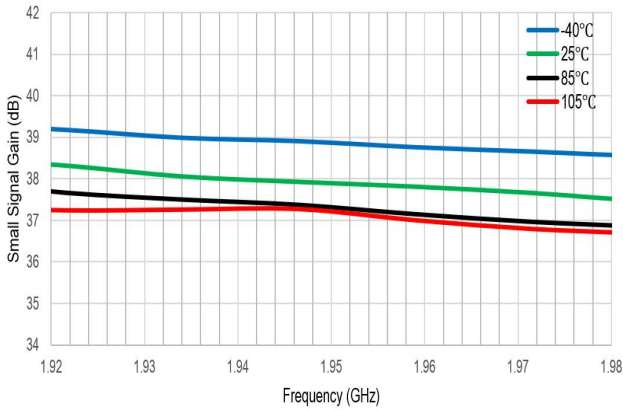

Figure 20. Small Signal Gain (dB) vs Frequency (GHz)

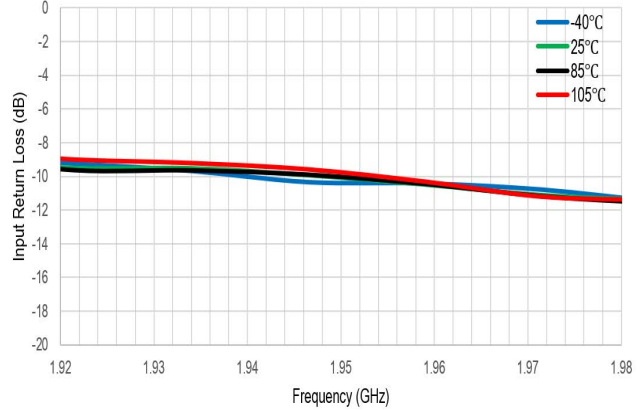

Figure 21. Input Return Loss (dB) vs Frequency (GHz)

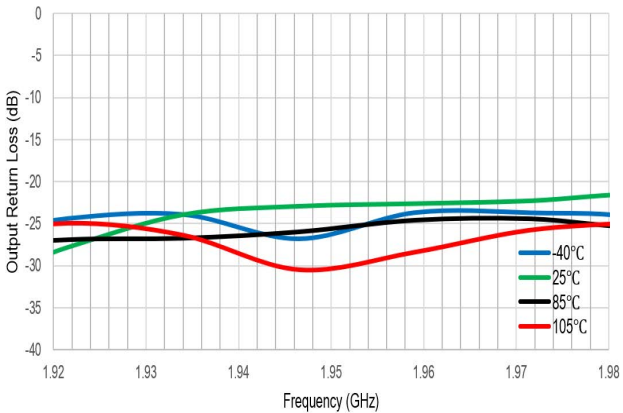

Figure 22. Output Return Loss (dB) vs Frequency (GHz)

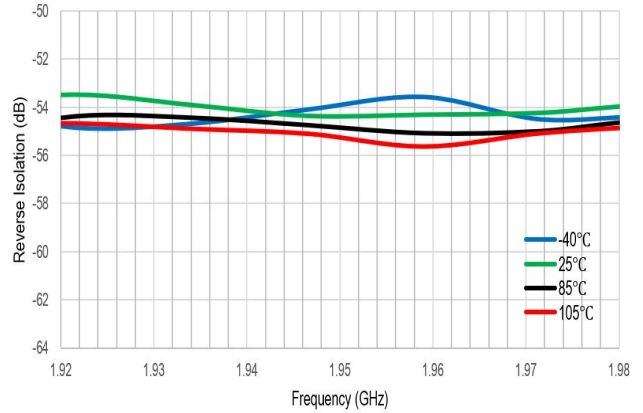

Figure 23. Reverse Isolation (dB) vs Frequency (GHz)

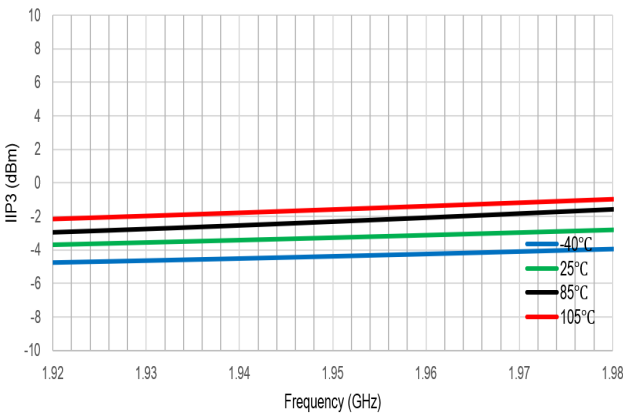

Figure 24. IIP3 (dBm) vs Frequency (GHz)

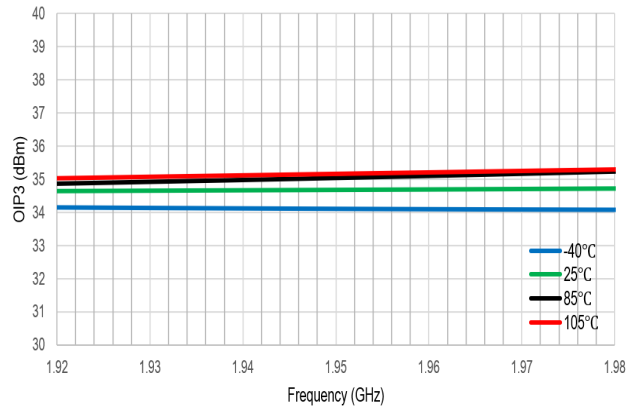

Figure 25. OIP3 (dBm) vs Frequency (GHz)

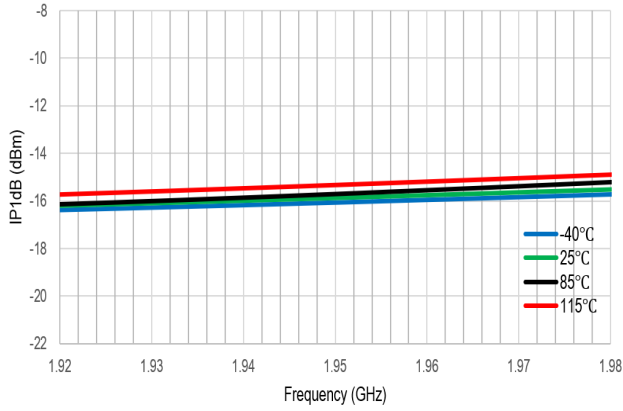

Figure 26. IP1dB (dBm) vs Frequency (GHz)

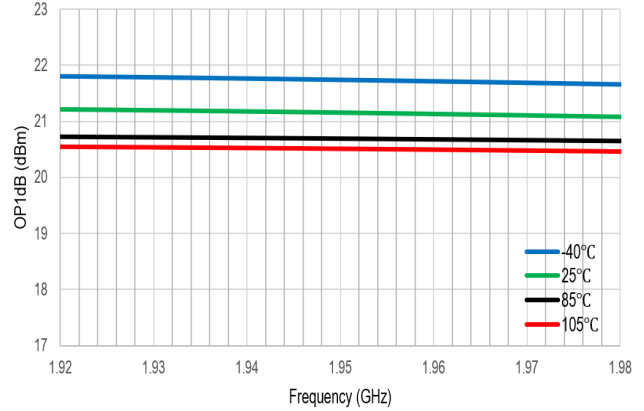

Figure 27. OP1dB (dBm) vs Frequency (GHz)

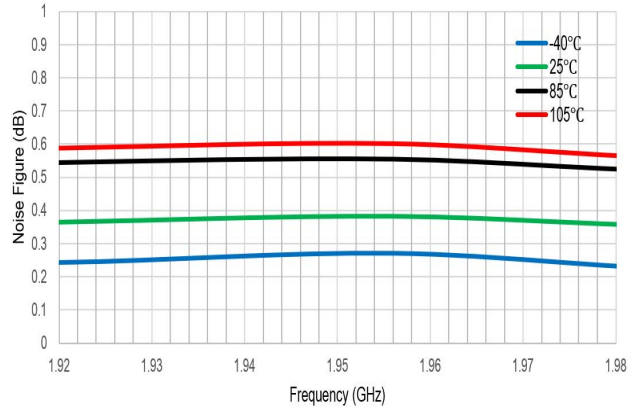

Figure 28. Noise Figure (dB) vs Frequency (GHz)

### Typical Performance Characteristics

0 to 20 GHz, VDD = +5 V, PIN = -30 dBm, Optimized for 1.7 to 2.7 GHz Operation, Unless Otherwise Noted

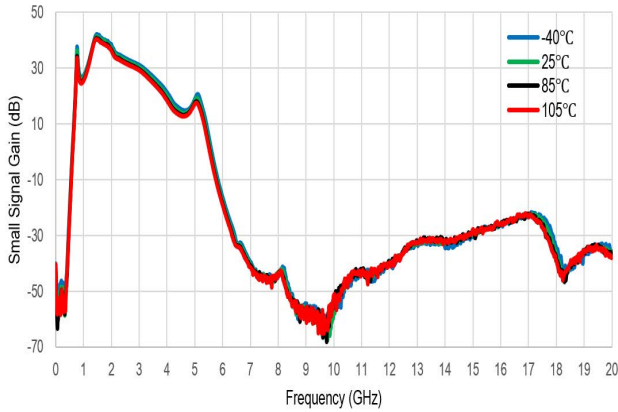

Figure 29. Small Signal Gain (dB) vs Frequency (GHz)

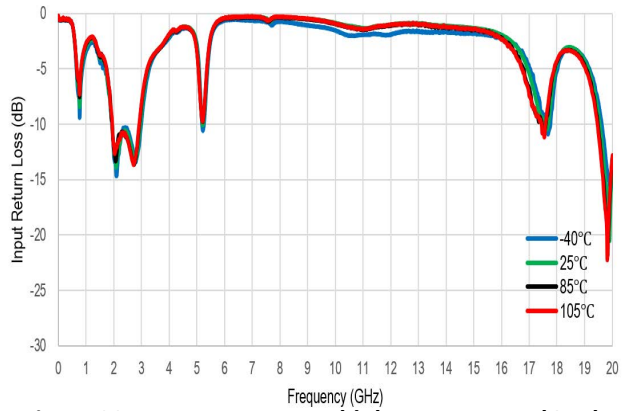

Figure 30. Input Return Loss (dB) vs Frequency (GHz)

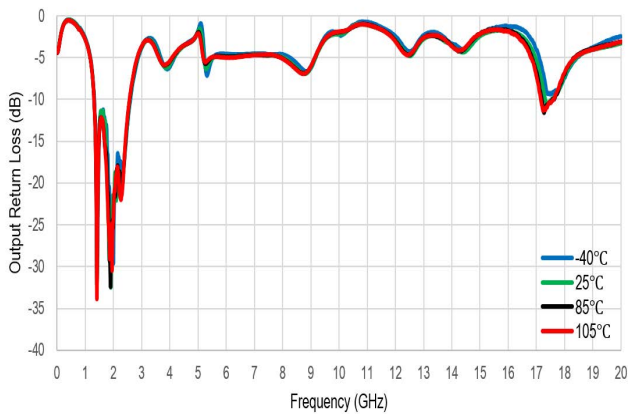

Figure 31. Output Return Loss (dB) vs Frequency (GHz)

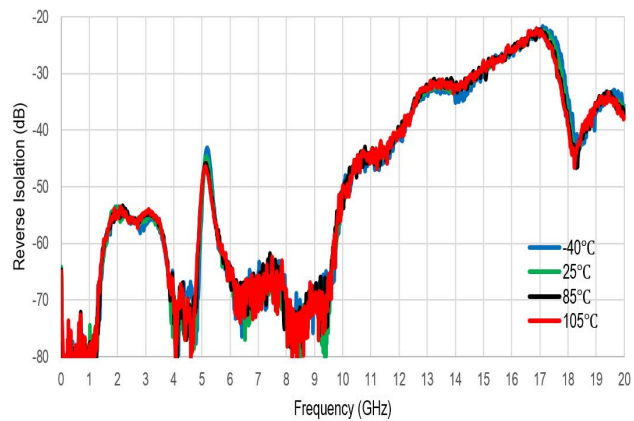

Figure 32. Reverse Isolation (dB) vs Frequency (GHz)

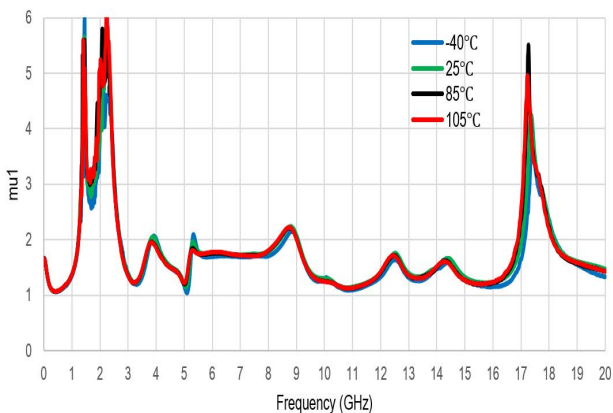

Figure 33. Stability Factor,  $\mu_1$  (dB) vs Frequency (GHz)

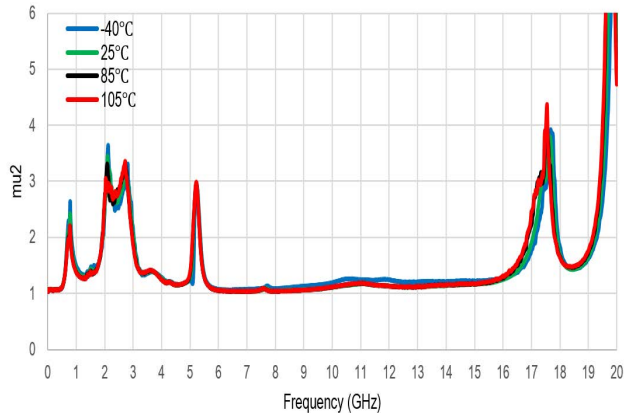
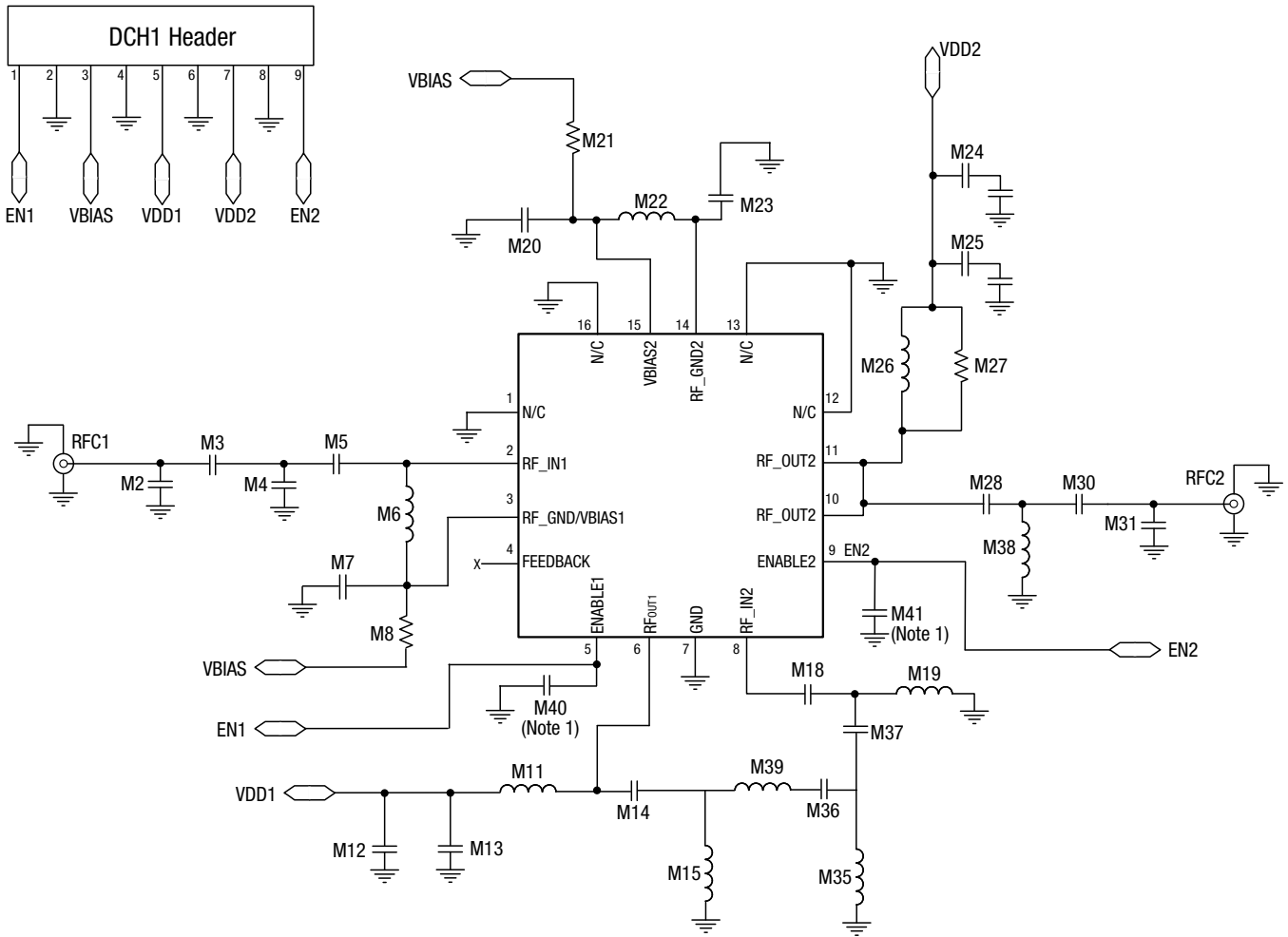

Figure 34. Stability Factor,  $\mu_2$  (dB) vs Frequency (GHz)

### Evaluation Board Description

SKY67180-306LF Evaluation Boards are used to test the performance of the SKY67180-306LF two-stage LNA. An Evaluation Board schematic diagram is provided in Figure 35 and represents device performance in a matched environment. Actual values used in application may vary particular to layout parasitics. Table 7 provides the Evaluation Board Bill of Materials (BOM) for 3.4 to 3.6 GHz operation. Table 8 provides the BOM for 2.6 GHz operation, and Table 9 is for 1.7 to 2.7 GHz operation.



*Note 1:*  
 M40 and M41 are general noise immunity bypass capacitors and are optional.  
 These capacitors are not recommended for applications with series resistance on control lines.

204918-010a

**Figure 35. SKY67180-306LF Evaluation Board Schematic**

Table 7. SKY67180-306LF Evaluation Board Bill of Materials (BOM) for 3.4 to 3.6 GHz Operation

Component	Description	Value	Size	Manufacturer	Mfr Part Number
M2	Capacitor	0.3 pF	0402	Murata	GJM1555C1HR30WB01
M3	Capacitor	2.7 pF	0402	Murata	GJM1555C1H2R7BB01
M4	Capacitor	0.5 pF	0402	Murata	GJM1555C1HR50WB01
M5	Capacitor	8.2 pF	0402	Murata	GJM1555C1H0R2BB01
M6	Inductor	18 nH	0402	Murata	LQW15AN18NH00
M7	DNP				
M8	Resistor	18 k $\Omega$	0402	Panasonic	ERJ2RKF1802X
M11	Inductor	3.3 nH	0402	Murata	LQG15HS3N3S02
M12	Capacitor	1000 pF	0402	Murata	GRM155R71H102KA01
M13	Capacitor	10000 pF	0402	Murata	GRM155R71H103KA88
M14	Capacitor	1.5 pF	0402	Murata	GJM1555C1H1R5BB01
M15	Inductor	1.3 nH	0402	TDK	MLG1005S1N3BT00
M18	Capacitor	0.6 pF	0402	Murata	GJM1555C1HR60WB01
M19	Inductor	1.8 nH	0402	TDK	MLK1005S1N8ST000
M20	Capacitor	5.6 pF	0402	Murata	GRM36C0G5R6C50
M21	Resistor	7.5 k $\Omega$	0402	Panasonic	ERJ2RKF7501X
M22	Inductor	15 nH	0402	Murata	LQW15AN15NH00
M23	Capacitor	1000 pF	0402	Murata	GRM155R71H102KA01
M24	Capacitor	1 $\mu$ F	0402	Murata	GRM155R61A105KE15
M25	Capacitor	10 pF	0402	Murata	GRM36C0G1R5C50
M26	Inductor	9.1 nH	0402	Murata	LQG15HN9N1J02D
M27	Resistor	560 $\Omega$	0402	Panasonic	ERJ2RKF5600X
M28	Capacitor	22 pF	0402	Murata	GJM1555C1H220GB01
M30	Inductor	1.0 nH	0402	TDK	MLK1005S1N0ST000
M31	Capacitor	1 pF	0402	Murata	GJM1555C1H1R0BB01
M35	DNP				
M36	Resistor	0 $\Omega$	0402	Panasonic	ERJ2GE0R00X
M37	Capacitor	3.9 pF	0402	Murata	GJM1555C1H3R9BB01
M38	DNP	0.2 pF	0402	Murata	GJM1555C1H0R2BB01
M39	Capacitor	22 pF	0402	Murata	GJM1555C1H220GB01
M40	DNP				
M41	Capacitor	1000 pF	0402	Murata	GRM155R71H102KA01

Table 8. SKY67180-306LF Evaluation Board Bill of Materials (BOM) for 2.6 GHz Operation

Component	Description	Value	Size	Manufacturer	Mfr Part Number
M2	Capacitor	1 pF	0402	Murata	GJM1555C1H1ROBB01
M3	Resistor	0 Ω	0402	Panasonic	ERJ2GE0R00X
M4	DNP				
M5	Capacitor	8.2 pF	0402	Murata	GJM1555C1H8R2CB01
M6	Inductor	18 nH	0402	Murata	LQW15AN18NH00
M7	DNP				
M8	Resistor	11 kΩ	0402	Panasonic	ERJ2RKF1102X
M11	Inductor	3.3 nH	0402	Murata	LQG15HS3N3S02
M12	Capacitor	1000 pF	0402	Murata	GRM155R71H102KA01
M13	Capacitor	10000 pF	0402	Murata	GRM155R71H103KA88
M14	Capacitor	1.5 pF	0402	Murata	GJM1555C1H1R5BB01
M15	DNP				
M18	Capacitor	0.6 pF	0402	Murata	GJM1555C1HR60WB01
M19	Inductor	2.4 nH	0402	Murata	LQP15MN2N4W02
M20	Capacitor	5.6 pF	0402	Murata	GRM36C0G5R6C50
M21	Resistor	11 kΩ	0402	Panasonic	ERJ2RKF1102X
M22	Inductor	15 nH	0402	Murata	LQW15AN15NH00
M23	Capacitor	1000 pF	0402	Murata	GRM155R71H102KA01
M24	Capacitor	1 μF	0402	Murata	GRM155R61A105KE15
M25	Capacitor	10 pF	0402	Murata	GRM36C0G1R5C50
M26	Inductor	9.1 nH	0402	Murata	LQG15HN9N1J02D
M27	DNP				
M28	Capacitor	5.1 pF	0402	Murata	GJM1555C1H5R1WB01
M30	Resistor	0 Ω	0402	Panasonic	ERJ2GE0R00X
M31	DNP				
M35	DNP				
M36	Resistor	0 Ω	0402	Panasonic	ERJ2GE0R00X
M37	Capacitor	3.9 pF	0402	Murata	GJM1555C1H3R9BB01
M38	Inductor	3 nH	0402	Murata	LQP15MN3N0W02
M39	Capacitor	22 pF	0402	Murata	GJM1555C1H220GB01
M40	DNP				
M41	Capacitor	1000 pF	0402	Murata	GRM155R71H102KA01

Table 9. SKY67180-306LF Evaluation Board Bill of Materials (BOM) for 1.7 to 2.7 GHz Operation

Component	Description	Value	Size	Manufacturer	Part Number
M2	Capacitor	1.0 pF	0402	Murata	GJM1555C1H1ROBB01
M3	Inductor	1.3 nH	0402	Murata	LQW15AN1N3C80
M4	Capacitor	1.0 pF	0402	Murata	GJM1555C1H1ROBB01
M5	Capacitor	22 pF	0402	Murata	GJM1555C1H220GB01
M6	Inductor	8.3 nH	0402	Murata	LQW15AN8N3C10
M7	Capacitor	22 pF	0402	Murata	GJM1555C1H220GB01
M8	Resistor	11 kΩ	0402	Panasonic	ERJ2RKF1102X
M11	Inductor	2.7 nH	0402	Murata	LQG15HS2N7S02
M12	Capacitor	1000 pF	0402	Murata	GRM155R71H102KA01
M13	Capacitor	10000 pF	0402	Murata	GRM155R71H103KA88
M14	Capacitor	1.5 pF	0402	Murata	GJM1555C1H1R5BB01
M15	Inductor	8.2 nH	0402	Murata	LQG15HS8N2J02
M18	Capacitor	2.0 pF	0402	Murata	GRM1555C1H2R0BA01
M19	Capacitor	0.5 pF	0402	Murata	GJM1555C1H1R50WB01
M20	Capacitor	5.6 pF	0402	Murata	GRM36C0G5R6C50
M21	Resistor	11 kΩ	0402	Panasonic	ERJ2RKF1102X
M22	Inductor	15 nH	0402	Murata	LQW15AN15NH00
M23	Capacitor	1000 pF	0402	Murata	GRM155R71H102KA01
M24	Capacitor	1 uF	0402	Murata	GRM155R61A105KE15
M25	Capacitor	10 pF	0402	Murata	GRM36C0G1R5C50
M26	Inductor	3.3 nH	0402	Murata	LQG15HS3N3S02
M27	DNP				
M28	Capacitor	22 pF	0402	Murata	GRM1555C1H220JA01
M30	Resistor	0 Ω	0402	Panasonic	ERJ2GE0R00X
M31	DNP				
M35	DNP	DNP	0402		
M36	Resistor	0 Ω	0402	Panasonic	ERJ2GE0R00X
M37	Capacitor	22 pF	0402	Murata	GRM1555C1H220JA01
M38	Resistor	200 Ω	0402	Panasonic	ERJ2RKF2000X
M39	Capacitor	22 pF	0402	Murata	GJM1555C1H220GB01
M40	DNP				
M41	Capacitor	1000 pF	0402	Murata	GRM155R71H102KA01



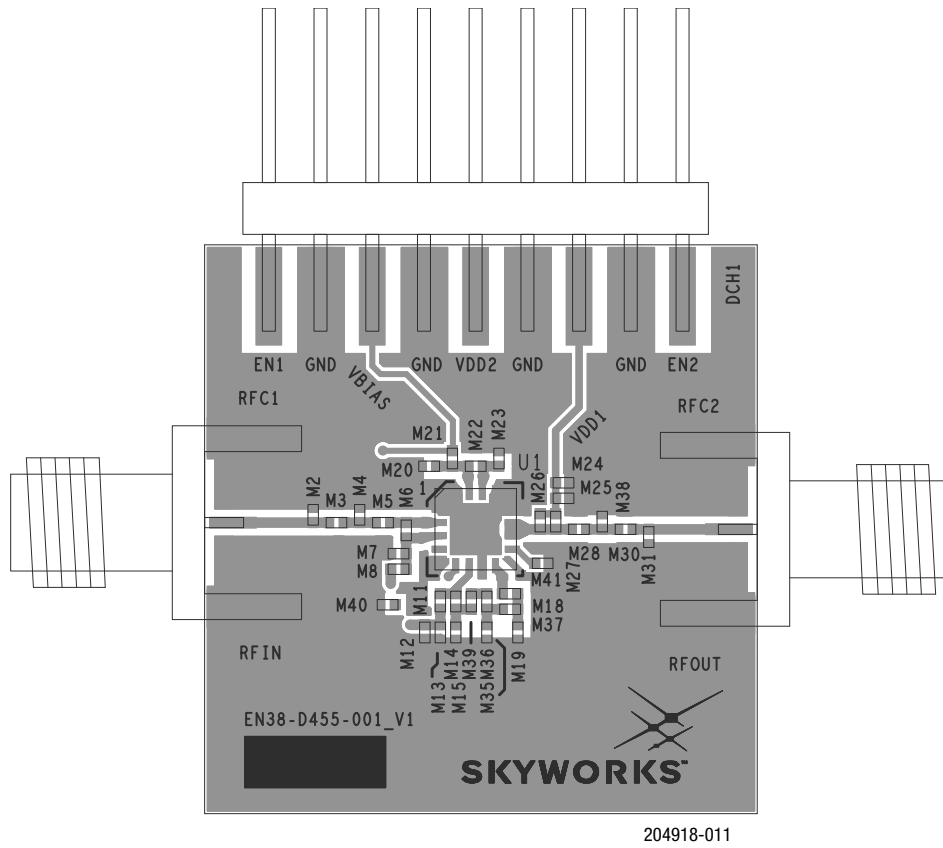

Figure 36. SKY67180-306LF Evaluation Board Assembly Diagram

### Package Dimensions

The PCB layout footprint for the SKY67180-306LF is shown below. Typical part markings are noted in Figure 38. Package dimensions are shown in Figure 39, and tape and reel dimensions are provided in Figure 40.

### Package and Handling Information

Instructions on the shipping container label regarding exposure to moisture after the container seal is broken must be followed. Otherwise, problems related to moisture absorption may occur when the part is subjected to high temperature during solder assembly.

The SKY67180-306LF is rated to Moisture Sensitivity Level 1 (MSL1) at 260 °C. It can be used for lead or lead-free soldering. For additional information, refer to the Skyworks Application Note, Solder Reflow Information, document number 200164.

Care must be taken when attaching this product, whether it is done manually or in a production solder reflow environment. Production quantities of this product are shipped in a standard tape and reel format.

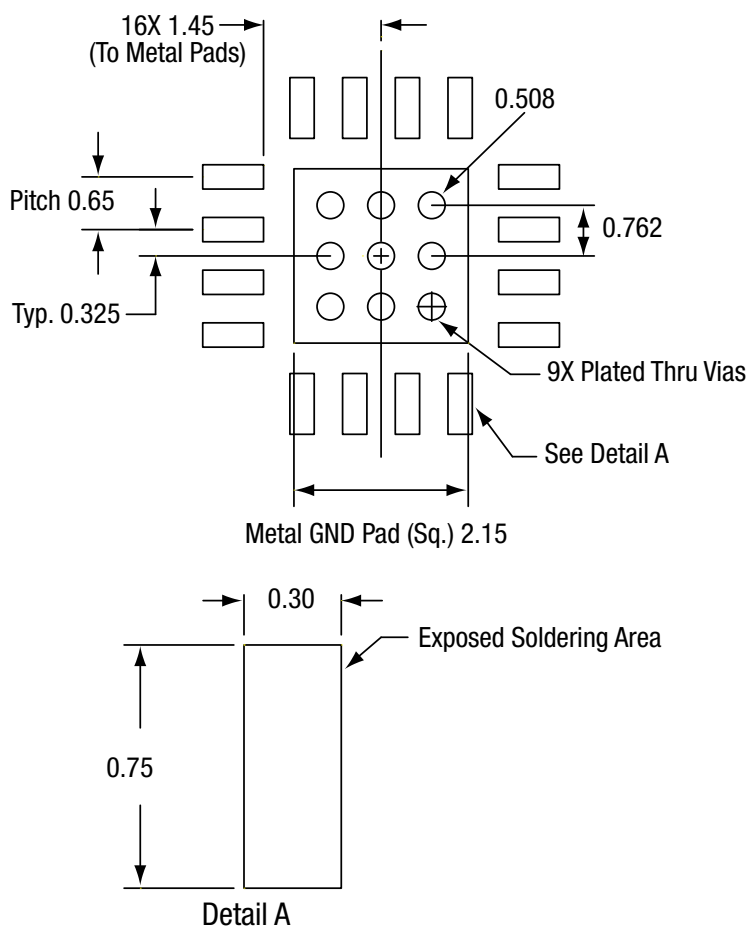

All measurements in millimeters

204918-012

Figure 37. SKY67180-306LF PCB Layout Footprint

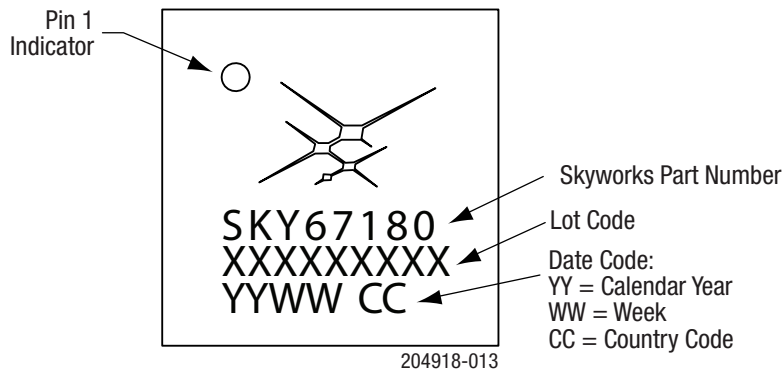
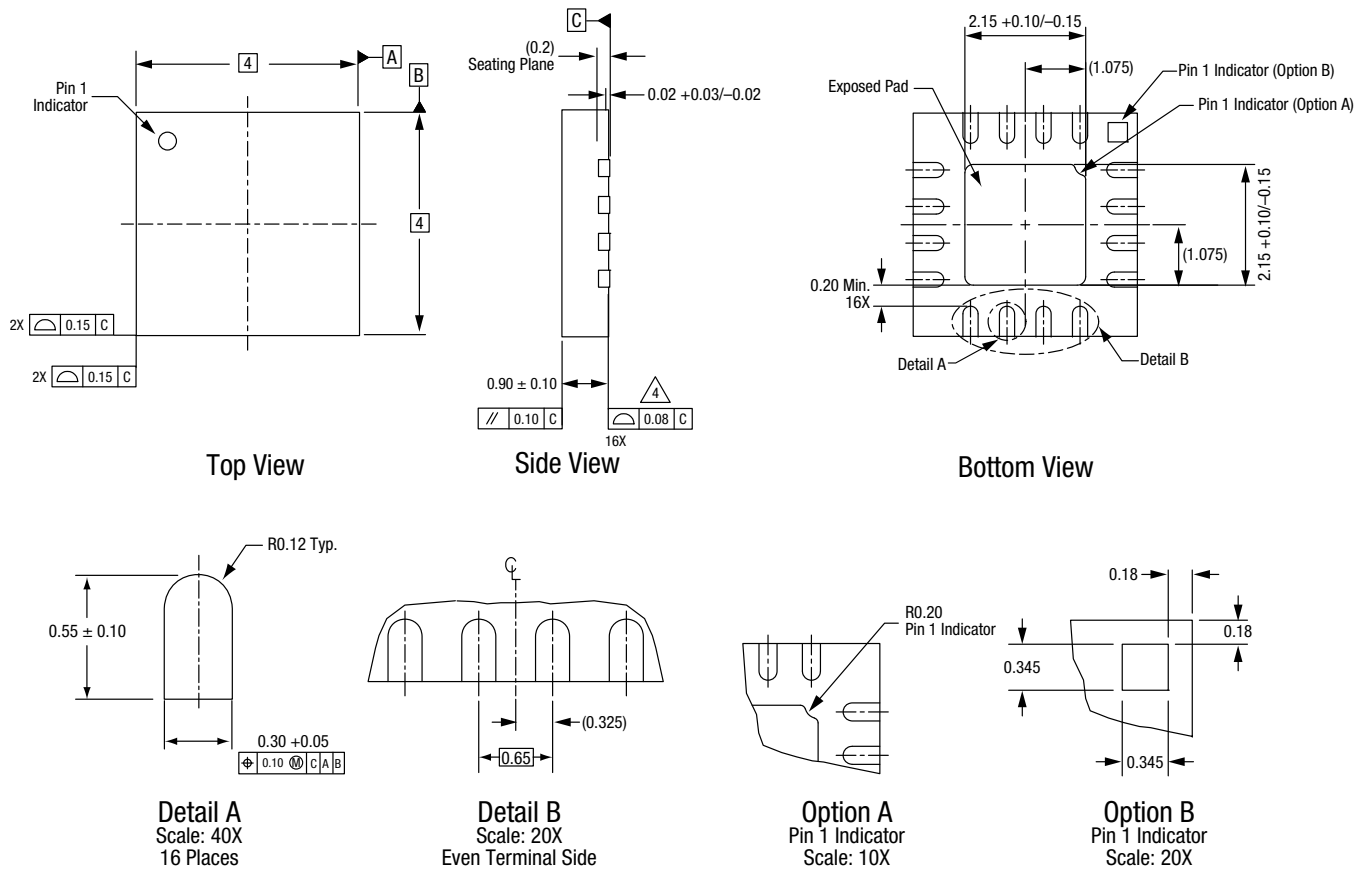

Figure 38. SKY67180-306LF Typical Part Marking



Notes:

1. All measurements are in millimeters.
2. Dimensions and tolerances according to ASME Y14.5M-1994.
3. Coplanarity applies to the exposed heat sink slug as well as the terminals.
4. Package may have option A or option B pin 1 indicator.

204196-014

Figure 39. SKY67180-306LF Package Dimensions

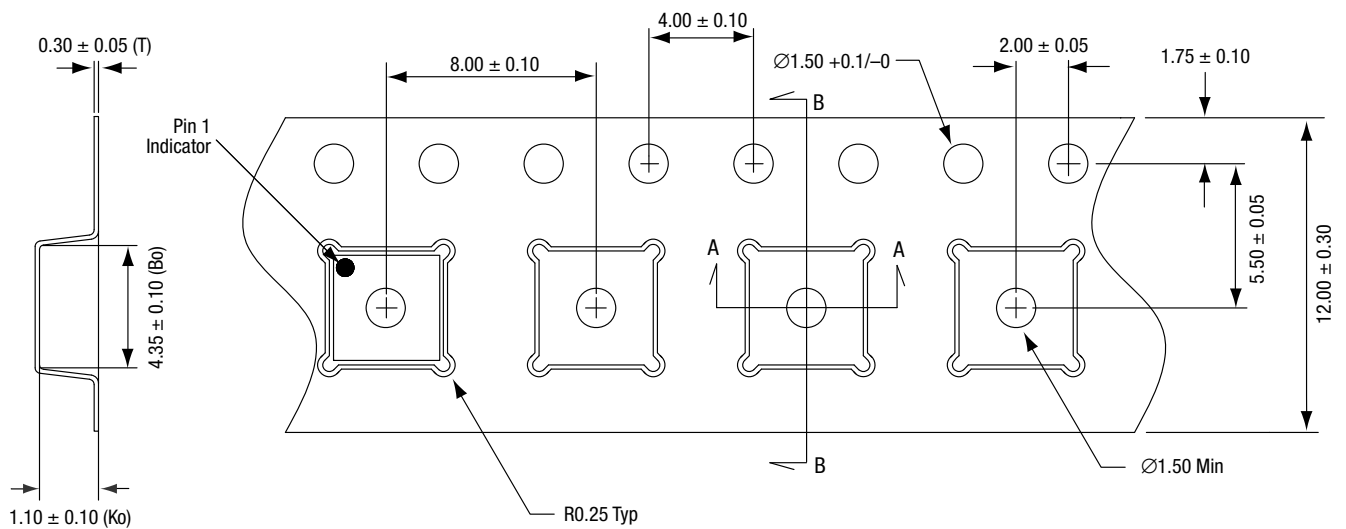

Detail B

Notes:

1. Carrier tape material: black conductive polystyrene, non-bakeable
2. Cover tape material: transparent conductive HSA
3. Cover tape size: 9.2 mm width
4. ESD surface resistivity is  $\geq 1 \times 10^5 \sim \leq 1 \times 10^{10}$  Ohms/square per EIA, JEDEC TNR Specification.
5. All measurements are in millimeters

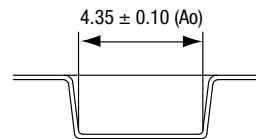

Detail A

204196-015

Figure 40. SKY67180-306LF Tape and Reel Dimensions

## Ordering Information

Part Number	Part Description	Evaluation Board Description	Evaluation Board Part Number
SKY67180-306LF	1.5 to 3.8 GHz two-stage, high-gain low-noise amplifier	3.4 to 3.6 GHz operation	SKY67180-306EK1
		2.6 GHz operation	SKY67180-306EK2
		1.7 to 2.7 GHz operation	SKY67180-306EK3

Copyright © 2018, 2023, Skyworks Solutions, Inc. All Rights Reserved.

Information in this document is provided in connection with Skyworks Solutions, Inc. ("Skyworks") products or services. These materials, including the information contained herein, are provided by Skyworks as a service to its customers and may be used for informational purposes only by the customer. Skyworks assumes no responsibility for errors or omissions in these materials or the information contained herein. Skyworks may change its documentation, products, services, specifications or product descriptions at any time, without notice. Skyworks makes no commitment to update the materials or information and shall have no responsibility whatsoever for conflicts, incompatibilities, or other difficulties arising from any future changes.

No license, whether express, implied, by estoppel or otherwise, is granted to any intellectual property rights by this document. Skyworks assumes no liability for any materials, products or information provided hereunder, including the sale, distribution, reproduction or use of Skyworks products, information or materials, except as may be provided in Skyworks' Terms and Conditions of Sale.

THE MATERIALS, PRODUCTS AND INFORMATION ARE PROVIDED "AS IS" WITHOUT WARRANTY OF ANY KIND, WHETHER EXPRESS, IMPLIED, STATUTORY, OR OTHERWISE, INCLUDING FITNESS FOR A PARTICULAR PURPOSE OR USE, MERCHANTABILITY, PERFORMANCE, QUALITY OR NON-INFRINGEMENT OF ANY INTELLECTUAL PROPERTY RIGHT; ALL SUCH WARRANTIES ARE HEREBY EXPRESSLY DISCLAIMED. SKYWORKS DOES NOT WARRANT THE ACCURACY OR COMPLETENESS OF THE INFORMATION, TEXT, GRAPHICS OR OTHER ITEMS CONTAINED WITHIN THESE MATERIALS. SKYWORKS SHALL NOT BE LIABLE FOR ANY DAMAGES, INCLUDING BUT NOT LIMITED TO ANY SPECIAL, INDIRECT, INCIDENTAL, STATUTORY, OR CONSEQUENTIAL DAMAGES, INCLUDING WITHOUT LIMITATION, LOST REVENUES OR LOST PROFITS THAT MAY RESULT FROM THE USE OF THE MATERIALS OR INFORMATION, WHETHER OR NOT THE RECIPIENT OF MATERIALS HAS BEEN ADVISED OF THE POSSIBILITY OF SUCH DAMAGE.

Skyworks products are not intended for use in medical, lifesaving or life-sustaining applications, or other equipment in which the failure of the Skyworks products could lead to personal injury, death, physical or environmental damage. Skyworks customers using or selling Skyworks products for use in such applications do so at their own risk and agree to fully indemnify Skyworks for any damages resulting from such improper use or sale.

Customers are responsible for their products and applications using Skyworks products, which may deviate from published specifications as a result of design defects, errors, or operation of products outside of published parameters or design specifications. Customers should include design and operating safeguards to minimize these and other risks. Skyworks assumes no liability for applications assistance, customer product design, or damage to any equipment resulting from the use of Skyworks products outside of Skyworks' published specifications or parameters.

Skyworks, the Skyworks symbol, Sky5®, SkyOne®, SkyBlue™, Skyworks Green™, ClockBuilder®, DSPLL®, ISOModem®, ProSLIC®, SiPHY®, and RFelC® are trademarks or registered trademarks of Skyworks Solutions, Inc. or its subsidiaries in the United States and other countries. Third-party brands and names are for identification purposes only and are the property of their respective owners. Additional information, including relevant terms and conditions, posted at [www.skyworksinc.com](http://www.skyworksinc.com), are incorporated by reference.

# Mouser Electronics

Authorized Distributor

Click to View Pricing, Inventory, Delivery & Lifecycle Information:

[Skyworks:](#)

[SKY67180-306LF](#)