



# Weller®



## WXR 3

- DE** Originalbetriebsanleitung
- GB** Translation of the original instructions
- ES** Traducción del manual original
- FR** Traduction de la notice originale
- IT** Traduzione delle istruzioni originali
- PT** Tradução do manual original
- NL** Vertaling van de oorspronkelijke gebruiksaanwijzing
- SV** Översättning av bruksanvisning i original
- DK** Oversættelse af den originale brugsanvisning
- FI** Alkuperäisten ohjeiden käännös
- GR** Μετάφραση του πρωτοτύπου των οδηγιών χρήσης
- TR** Orijinal işletme talimatı çevirisi
- CZ** Překlad původního návodu k používání
- PL** Tłumaczeniem instrukcji oryginalnej
- HU** Eredeti használati utasítás fordítása
- SK** Preklad pôvodného návodu na použitie
- SL** Prevod izvirnih navodil
- EE** algupärase kasutusjuhendi tõlge
- LV** Instrukciju tulkojumam no oriģinālvalodas
- LT** Originalios instrukcijos vertimas
- BG** Превод на оригиналната инструкция
- RO** Traducere a instructiunilor originale
- HR** Prijevod originalnih uputa
- RU** Оригинальное руководство по эксплуатации

**Air**

WXHAP 200



WXP 65



WXP 120



WXP 200

**Vac**



WXMT



WXDV 120



WXDP 120

**WX**



**Air** **Vac**

ON / OFF  
I / O

WXR 3

400 380 350

WXR 200 WXR 300 WXR 350

Weller  
Made in Germany

Vac

Air

Pick Up

r-1- r-2- r-3-

r-1- r-2- r-3-

r-1 2 3- PickUp

**Pick Up**



WVP



WRK

# Quick Reference WXR 3

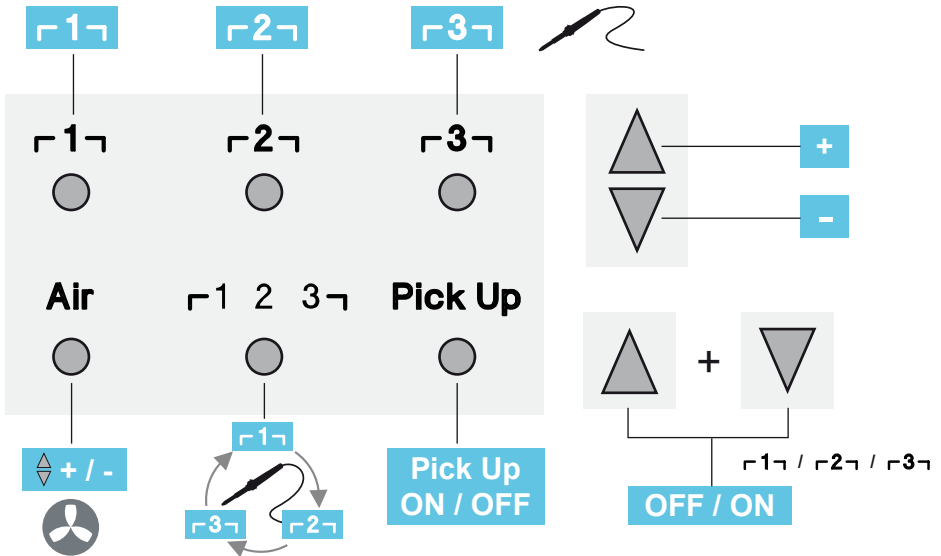

DE Menüaufruf  
 GB Open Menu  
 ES Acceso al Menú  
 FR Appel du menu  
 IT Richiama il menu  
 PT Activação do menu  
 NL Oproep Menu  
 SV Öppna meny

DK Hentning af menu  
 FI Valikon haku näyttöön  
 GR Κλήση μενού  
 TR Menüsinü açma  
 CZ Spuštění Nabídky položek  
 PL Wywołanie menu  
 HU Menü előhívása  
 SK Vyvolanie menu

SL Priklic menija  
 EE Menüü avamine  
 LV Izvēlnes izsaukšana  
 LT Meniu iškvietia  
 BG Повикване на менюто  
 RO Apelarea meniului  
 HR Pozivanje izbornika  
 RU ВЫЗОВ МЕНЮ

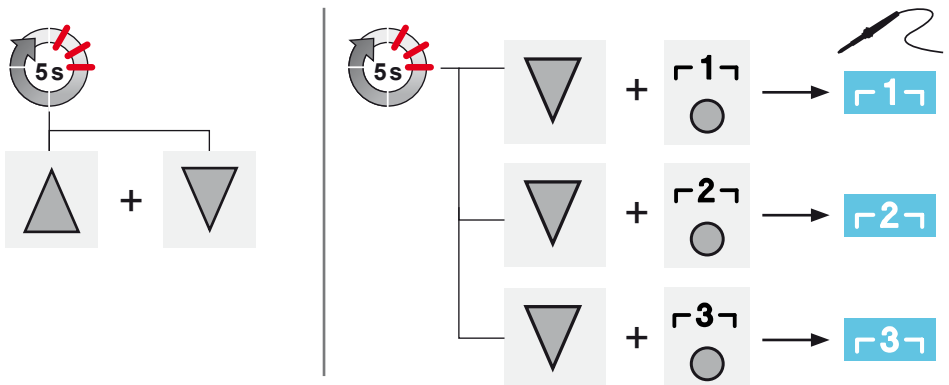

DE Lieferumfang  
 GB Included in delivery  
 ES Piezas suministradas  
 FR Fourniture  
 IT Dotazione  
 PT Fornecimento  
 NL Meegeleverd van de levering  
 SV Leveransomfattning

DK Leveringsomfang  
 FI Toimitussisältö  
 GR Υλικά παράδοσης  
 TR Teslimat kapsamı  
 CZ Rozsah dodávky  
 PL Zakres dostawy  
 HU Szállítási terjedelem  
 SK Rozsah dodávky

SL Obseg pošiljke  
 EE Tame sisu  
 LV Piegādes komplekts  
 LT Komplektas  
 BG Обем на доставката  
 RO Pachetul de livrare  
 HR Popratna oprema  
 RU Комплект поставки

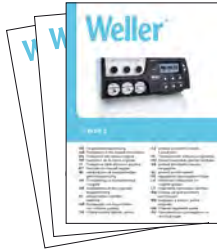

DE Zubehör  
 GB Accessory  
 ES Accesorio  
 FR Accessoires  
 IT Accessorio  
 PT Acessório  
 NL Toebehoren  
 SV Tillbehör

DK Tilbehør  
 FI Lisälaite  
 GR Εξαρτήματα  
 TR Aksesuar  
 CZ Příslušenství  
 PL Wyposażenie  
 HU Tartozékok  
 SK Príslušenstvo

SL Oprema  
 EE Tarvikud  
 LV Piederumi  
 LT Priedas  
 BG Принадлежности  
 RO Accesorii  
 HR Pribor  
 RU Оснастка



PC  
T005 87 647 11



WFE/WHP  
T005 87 647 12



WX  
T005 87 647 10



WX Hub  
T005 87 647 26



WX Foot switch  
T005 87 647 46



WXS B 200



WHP 1000  
 WHP 3000, 600 W  
 WHP 3000, 1200 W  
 WXHP 120, 120 W



Zero Smog 6V / WFE 4S  
 Zero Smog 20T / WFE 20D  
 Zero Smog 4V



WFV 60A  
T005 87 627 46

DE Inbetriebnahme  
 GB Starting up the device  
 ES Puesta en servicio del aparato  
 FR Mise en service de l'appareil  
 IT Messa in funzione dell'apparecchio  
 PT Colocação do aparelho em serviço  
 NL Toestel in gebruik nemen  
 SV Ta lödstationen i drift  
 DK Ibrugtagning af apparatet  
 FI Laitteen käyttöönotto  
 GR Θέση της συσκευής σε λειτουργία  
 TR Cihazı işletime alma

CZ Uvedení zařízení do provozu  
 PL Uruchamianie urządzenia  
 HU A készülék üzembe helyezésé  
 SK Uvedenie zariadenia do prevádzky  
 SL Začetek dela z napravo  
 EE Seadme kasutuselevõtt  
 LV Iekārtas lietošanas sākšana  
 LT Prietaiso paruošimas eksploatuoti  
 BG Включване на уреда  
 RO Punerea în funcțiune a aparatului  
 HR Uređaj pustiti u rad  
 RU Ввод устройства в эксплуатацию

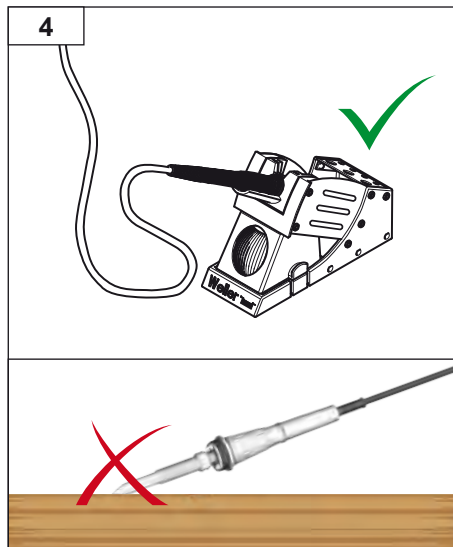
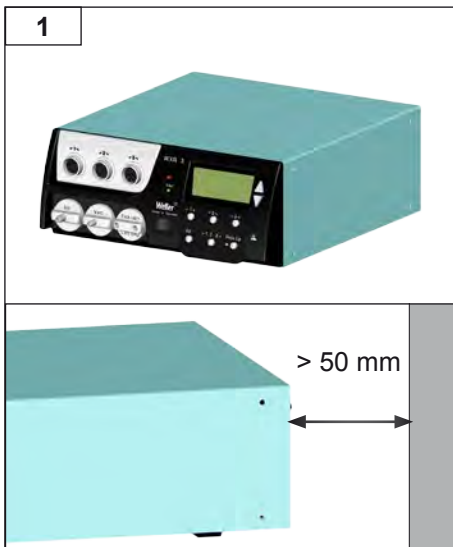

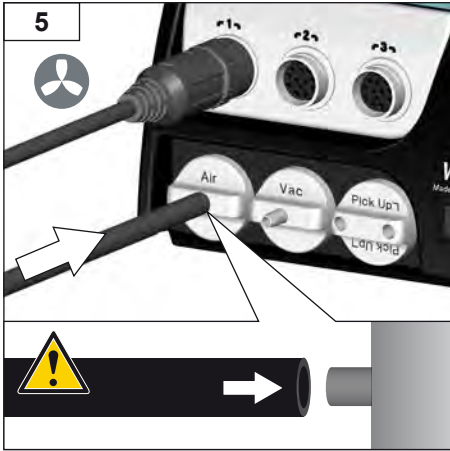

TIP



WXHAP 200

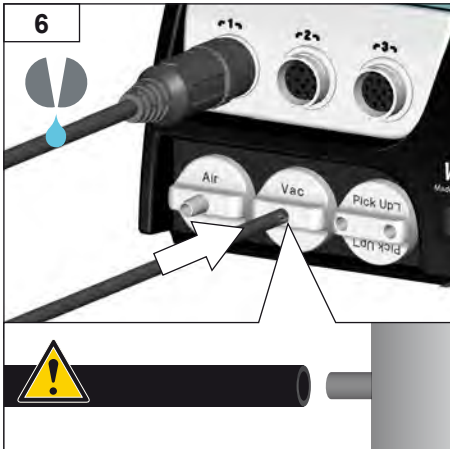

TIP



WXDP 120



WXDV 120

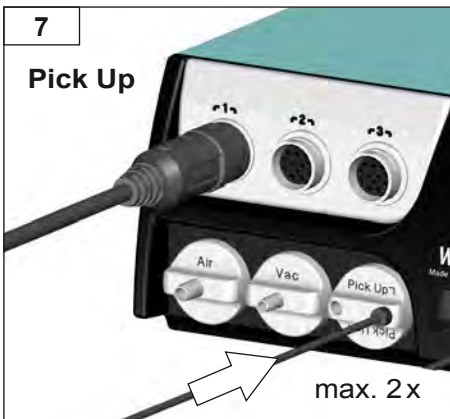

TIP



WVP



WRK

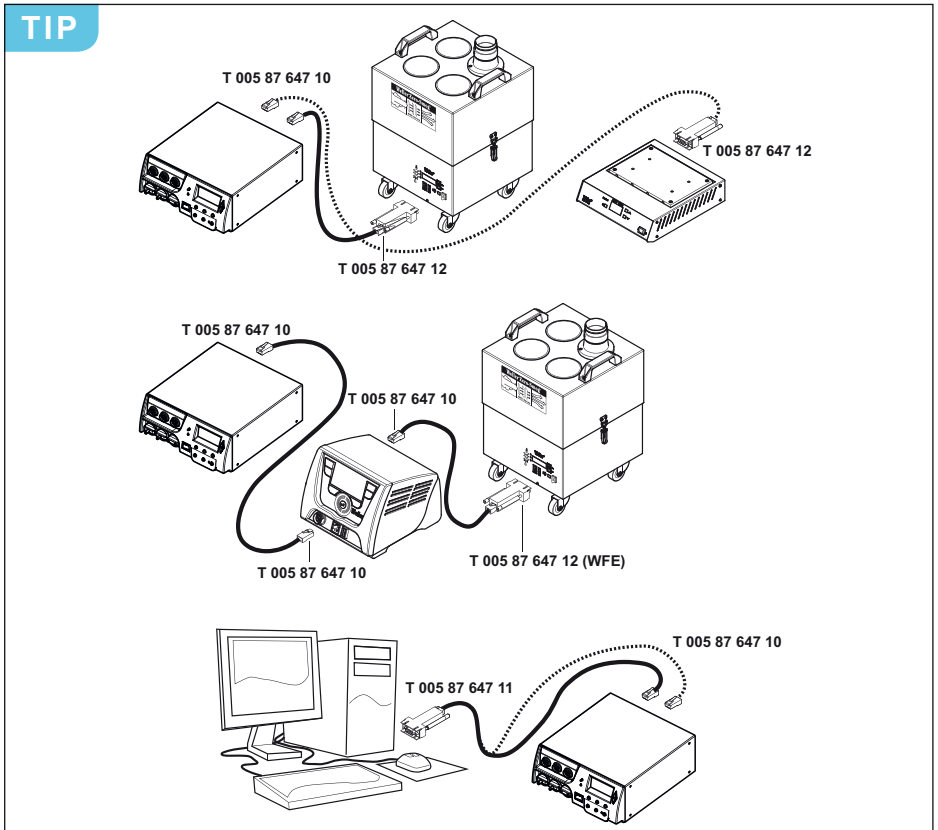
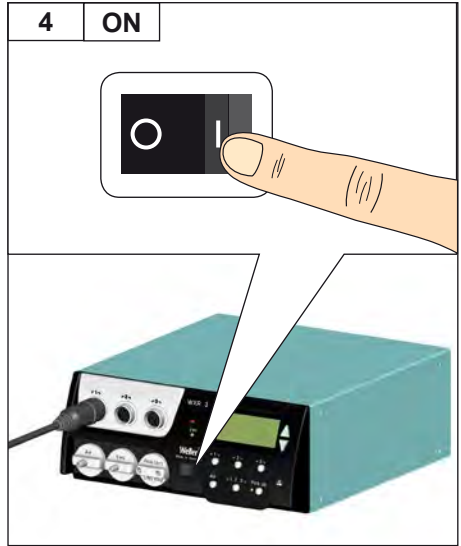
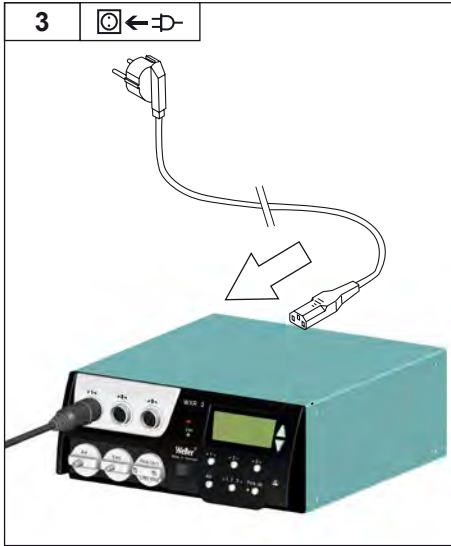

DE Filterwechsel  
 GB Filter change  
 ES Cambio de filtro  
 FR Remplacement du filtre  
 IT Sostituzione del filtro  
 PT Troca do filtro  
 NL Wissel van de filter  
 SV Byte av filter  
 DK Filterskift  
 FI Suodattimen vaihto  
 GR Αλλαγή φίλτρου  
 TR Filtre deęişimi

CZ Výměna filtru  
 PL Wymiana filtra  
 HU Szűrőcsere  
 SK Výmena filtra  
 SL Menjava filtra  
 EE Filtri vahetamine  
 LV Filtra nomaiņa  
 LT Filtrų keitimas  
 BG Смяна на филтъра  
 RO Schimbarea filtrului  
 HR Mjenjanje filtra  
 RU Замена фильтров

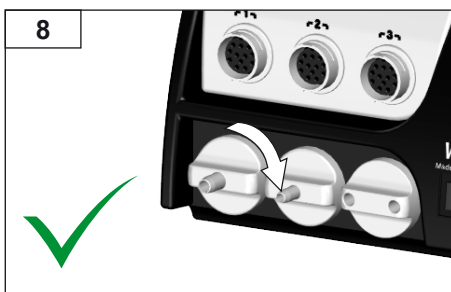
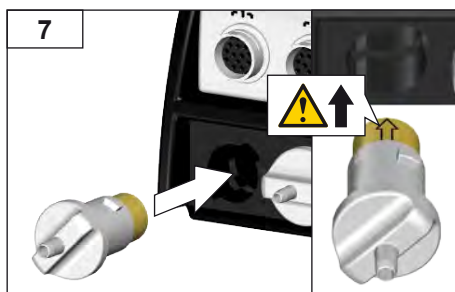
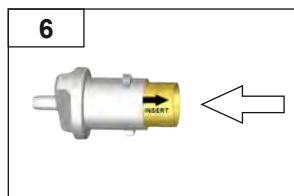
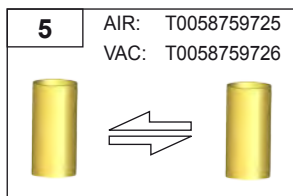
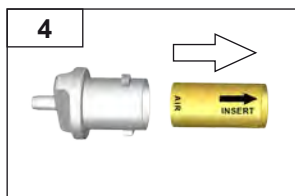
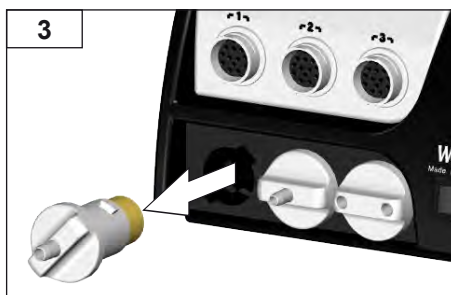
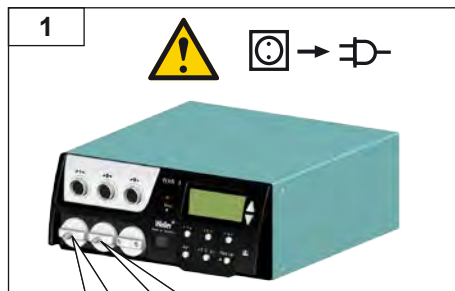



DE Kanal auswählen  
 GB Select channel  
 ES Seleccionar canal  
 FR Sélectionner un canal  
 IT Selezione del canale  
 PT Seleccionar o canal  
 NL Kanaal selecteren  
 SV Välj kanal.  
 DK Vælg kanal  
 FI Kanavan valinta  
 GR Επιλογή καναλιού  
 TR Kanal seçimi

CZ Volba kanálu  
 PL Wybór kanału  
 HU Csatorna kiválasztás  
 SK Zvoľte kanál  
 SL Izbira kanala  
 EE kanali valimine  
 LV Kanāla izvēle  
 LT Pasirinkite kanalą  
 BG Избeрете канал  
 RO Selectarea canalului  
 HR Odaberite kanal  
 RU Выбор канала



DE Kanal wechseln  
 GB Change channel  
 ES Cambiar de canal  
 FR Changer de canal  
 IT Cambio del canale  
 PT Mudar o canal  
 NL Kanaal wisselen  
 SV Byt kanal  
 DK Skift kanal  
 FI Kanavan vaihto  
 GR Αλλαγή καναλιού  
 RU Канал дежйtirme

CZ Změna kanálu  
 PL Zmiana kanału  
 HU Csatornaváltás  
 SK Zmeňte kanál  
 SL Menjava kanala  
 EE kanali vahetamine  
 LV Kanāla nomaīņa  
 LT Pakeiskite kanalą  
 BG Прoмяна на канал  
 RO Schimbarea canalului  
 HR Promijenite kanal  
 RU Смена канала

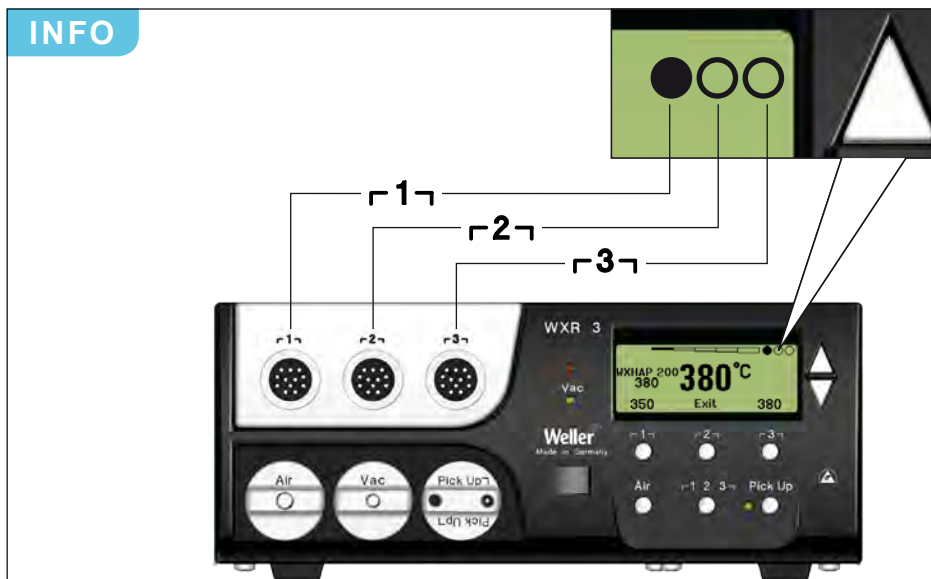

DE Heißluft  
 GB Hot air  
 ES Aire caliente  
 FR Air chaud  
 IT Aria calda  
 PT Ar quente  
 NL Hete lucht  
 SV Hetluft  
 DK Varmluft  
 FI Kuumailma  
 GR Καυτός αέρας  
 TR Sıcak hava

CZ Horký vzduch  
 PL Gorące powietrze  
 HU Forrólevegő  
 SK Horúci vzduch  
 SL Vroč zrak  
 EE kuum õhk  
 LV Karsts gaiss  
 LT Karštas oras  
 BG Горещ въздух  
 RO Aer cald  
 HR Vrući zrak  
 RU Нагретый воздух

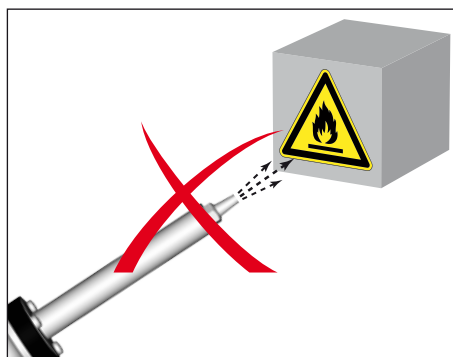
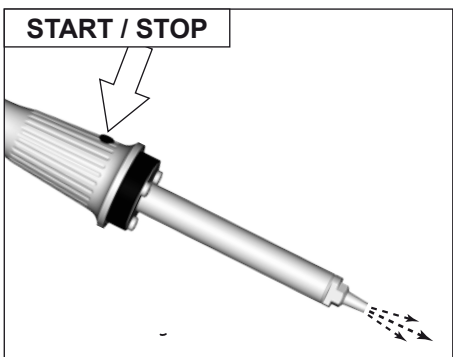
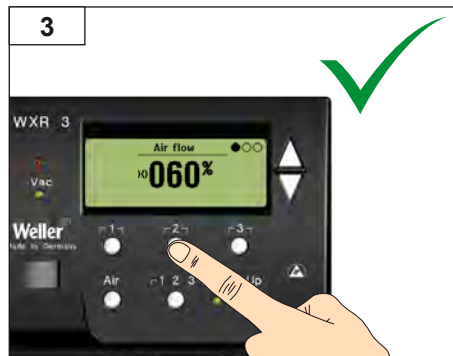
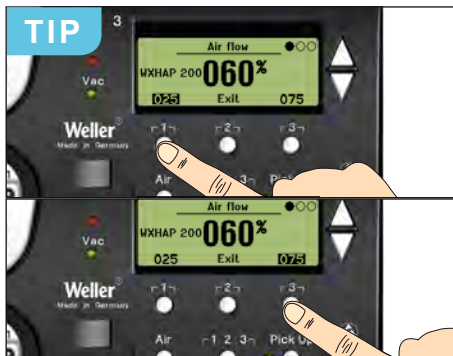
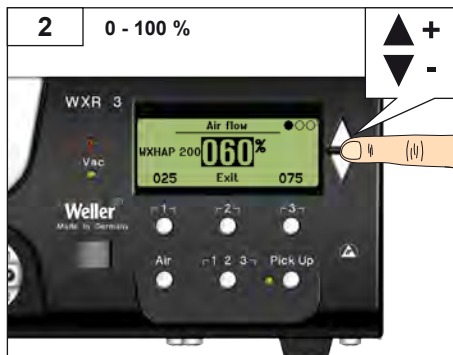

DE Pick Up - Vakuum  
 GB PickUp vacuum  
 ES Pick Up - Vacío  
 FR Pick Up - vide  
 IT Vuoto Pick-up  
 PT Vácuo PickUp  
 NL Pick Up - vacuüm  
 SV PickUp-vakuum  
 DK Pick Up - vakuum  
 FI Pick Up - tyhjiö  
 GR Pick Up - Κενό  
 RU Kaldırma vakumu

CZ Pick-up vakuom  
 PL Pick Up - próżnia  
 HU Pick Up - vákuum  
 SK Pick Up - vákuum  
 SL Pobiranje – podtlak  
 EE Pick Up - vaakum  
 LV Pēcēšana – vakuums  
 LT PICK UP vakuumas  
 BG колeно вакуум  
 RO Pick Up - vid  
 HR Pick Up - vakuum  
 RU Отбор вакуума

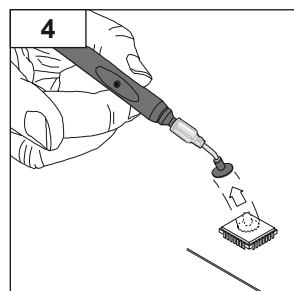
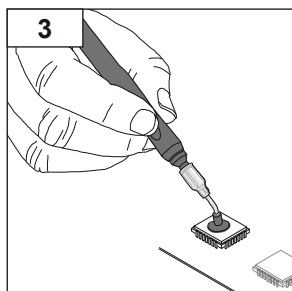
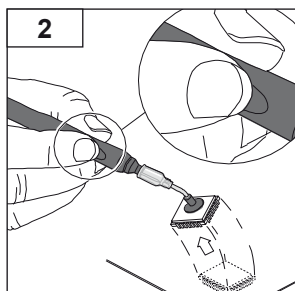
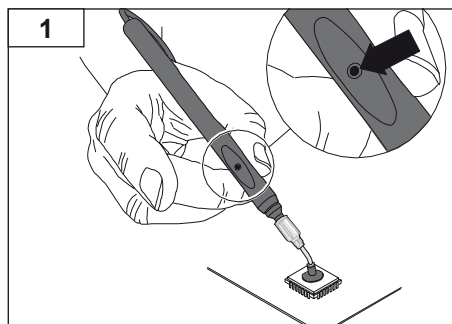
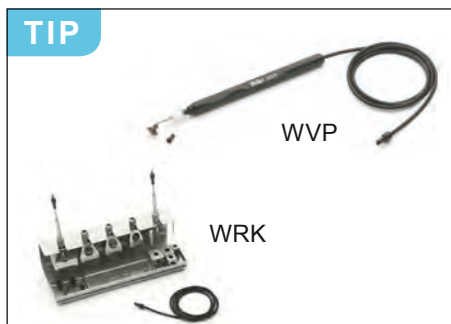

DE Kanal ein-/ ausschalten  
 GB Switching the channel on/ off  
 ES Conexión/ Desconexión del canal  
 FR Activation / désactivation du canal  
 IT Attivazione/ Disattivazione di un canale  
 PT Desligar/ ligar o canal  
 NL Kanaal uit-/ inschakelen  
 SV Koppla in/ ur kanal  
 DK Deaktivering/ aktivering af kanal  
 FI Kanavan pois-/ päällekytkentä  
 GR Απενεργοποίηση/ ενεργοποίηση καναλιού  
 TR Kanal kapatma/ açma

CZ Vypnutí/ zapnutí kanálu  
 PL Włączenie / wyłączenie kanału  
 HU Csatorna ki-/ bekapcsolása  
 SK Vypnutie/ zapnutie kanálu  
 SL Vkllop/ izkllop kanala  
 EE Kanali välja/ sisselülitamine  
 LV Kanālu izslēgšana/ ieslēgšana  
 LT Kanalo išjungimas / įjungimas  
 BG Вкл- / изключване на канал  
 RO Conectarea/deconectarea canalului  
 HR Uključivanje/isključivanje kanala  
 RU Выключение/включение канала



DE Solltemperatur  
 GB Nominal temperature  
 ES Temperatura de referencia  
 FR Température de consigne  
 IT Temperatura nominale  
 PT Temperatura nominal  
 NL Gewenste temperatuur  
 SV Börtemperatur  
 DK Nominel temperatur  
 FI Ohjelämpötila  
 GR Ονομαστική θερμοκρασία  
 TR Nominal sıcaklık

CZ Nominal sıcaklık  
 PL Temperatura zadana  
 HU Temperatura hőmérséklet  
 SK Požadovaná teplota  
 SL želena temperatura  
 EE Sihttemperatuur  
 LV Vēlamā temperatūra  
 LT Nustatytoji temperatūra  
 BG Заддена температура  
 RO Temperatura nominală  
 HR Zadana temperatura  
 RU Заданная температура

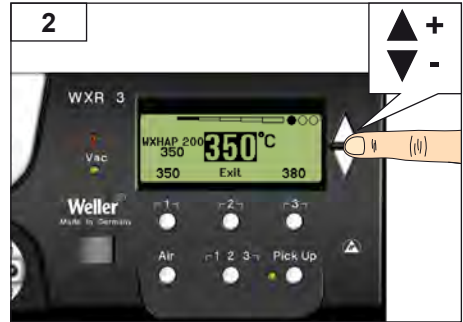
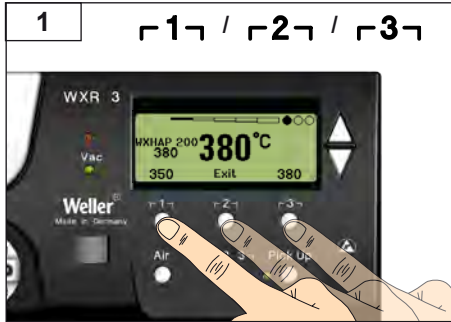

DE Festtemperatur auswählen  
 GB Select fixed temperature  
 ES Seleccionar un valor fijo de temperatura  
 FR Sélectionner la température fixe  
 IT Selezione della temperatura fissa  
 PT Seleccionar temperatura fixa  
 NL Vaste temperatuur selecteren  
 SV Välj fast temperatur  
 DK Vælg fast temperatur  
 FI Kiinteän lämpötilan valinta  
 GR Επιλογή της σταθερής θερμοκρασίας  
 TR Sabit sıcaklık seçilmesi

CZ Volba pevné teploty  
 PL Wybór stałej temperatury  
 HU Rögzített hőmérséklet kiválasztása  
 SK Zvoľte do pamäte fixnú teplotu  
 SL Izbira stalne temperature  
 EE Püsitemperatuuri valimine  
 LV Fiksētās temperatūras izvēle  
 LT Nustatytosios temperatūros parinktis  
 BG Избор на непроменлива температура  
 RO Selectarea temperaturii fixe  
 HR Odabir fiksne temperature  
 RU Выбор фиксированной температуры





DE Festtemperatur einstellen und speichern  
 GB Set and save fixed temperature  
 ES Ajustar / guardar un valor fijo de temperatura  
 FR Réglage et mémoriser la température fixe  
 IT Impostazione e memorizzazione della temperatura fissa  
 PT Ajustar e memorizar temperatura fixa  
 NL Vaste temperatuur instellen en opslaan  
 SV Ställ in fast temperatur och spara den  
 DK Indstil og gem fast temperatur  
 FI Kiinteän lämpötilan säätö ja tallennus  
 GR Ρύθμιση / αποθήκευση της σταθερής θερμοκρασίας  
 TR Sabit sıcaklık ayarlanmalıdır / kaydedilmelidir  
 CZ Nastavení a uložení pevné teploty

PL Ustawianie i zapis stałej temperatury  
 HU Rögzített hőmérséklet beállítása / mentése  
 SK Nastavte a uložte do fixnú teplotu  
 SL Nastavitev stalne temperature in shranitev  
 EE Püsitemperatuuri reguleerimine / salvestamine  
 LV Fiksētās temperatūras iestatīšana / saglabāšana  
 LT Nustatytosios temperatūros nustatymas ir išsaugojimas  
 BG Задаване и запаметяване на непроменлива температура  
 RO Setarea și salvarea temperaturii fixe  
 HR Namještanje i spremanje fiksne temperature  
 RU Установка и сохранение фиксированной температуры

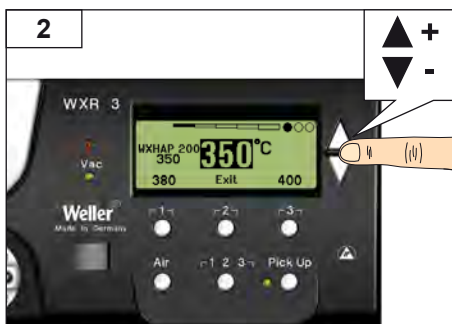
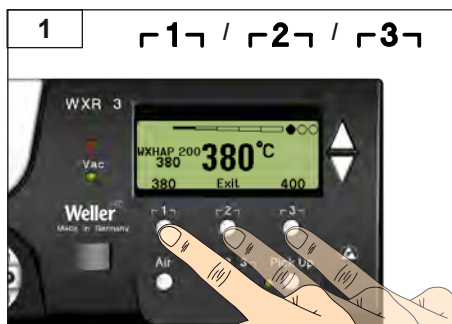



DE	Aufruf Parametermenü	CZ	Spuštění Nabídky položek Parametry
GB	Open Parameter menu	PL	Wywołanie menu parametrów
ES	Acceso al Menú de parámetros	HU	Paramétermenü előhívása
FR	Appel du menu Paramètres	SK	Vývolanie menu parametrov
IT	Richiama il menu Parametri	SL	Priklic menija parametrov
PT	Ativação do menu de parâmetros	EE	Parameetrimenüü avamine
NL	Oproep parametermenu	LV	Parametru izvēlnes izsaukšana
SV	Öppna parametermenyn	LT	Parametrų meniu iškvietia
DK	Hentning af parametermenu	BG	Разпределение на бутоните
FI	Parametrialikon haku näyttöön	RO	Alocarea tastelor
GR	Κλήση μενού των παραμέτρων	HR	Dodjela tipki
TR	Parametre menüsünü açma	RU	Вызов меню параметров



DE Auswahl/Einstellung Wert  
 GB Select/set value  
 ES Selección/Ajuste del valor  
 FR Sélection / réglage valeur  
 IT Selezione/Impostazione del valore  
 PT Selecção/regulação do valor  
 NL Keuze/instelling waarde  
 SV Val/inställning av värde  
 DK Valg/indstilling værdi  
 FI Arvon valinta/asetus  
 GR Επιλογή/ρύθμιση τιμής  
 TR Değer seçimi/ayarı

CZ Volba/Nastavení Hodnota  
 PL Wybór / ustawienie wartości  
 HU Érték kiválasztása / beállítása  
 SK Výber/nastavenie hodnoty  
 SL Izbira/nastavitev vrednosti  
 EE Väärtuse valik/seadmine  
 LV Vērtības izvēle/iestatīšana  
 LT Parinkties / nustatymo vertė  
 BG Избор/ настройка стойност  
 RO Selectarea/setarea valorii  
 HR Odabir/namještanje vrijednosti  
 RU Выбор/регулировка значения



DE Parametermenü verlassen  
 GB Exit parameter menu  
 ES Saldrá del menú de parámetros  
 FR Le menu Paramètres est quitté  
 IT Il menu Parametri viene terminato  
 PT O menu de parâmetros é abandonado  
 NL Parametermenu wordt verlaten  
 SV Parametermenyn stängs  
 DK Parametermenuen forlades  
 FI Parametrialikosta poistutaan  
 GR Το μενού των παραμέτρων εγκαταλείπεται  
 TR Parametre menüsünden çıkılır

CZ Nabídka položek Parametry se ukončí  
 PL Następuje wyjście z menu parametrów  
 HU Kilépés a paramétermenüből  
 SK Opustíte menu parametrov  
 SL Zapustili boste meni parametrov.  
 EE Väljutakse parameetrimenüüst  
 LV Parametru izvēlne tiek aizvērta  
 LT Parametų meniu uždaromas  
 BG Излизане от менюто за параметрите  
 RO Părăsirea meniului de parametri  
 HR Napuštanje Izbornika s parametrima  
 RU Выход из меню параметров

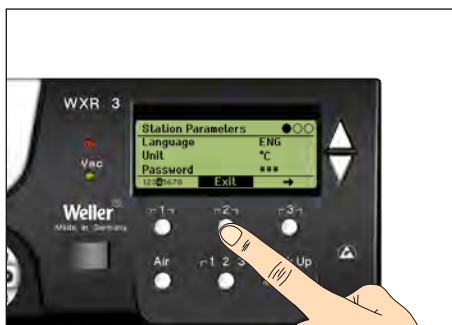

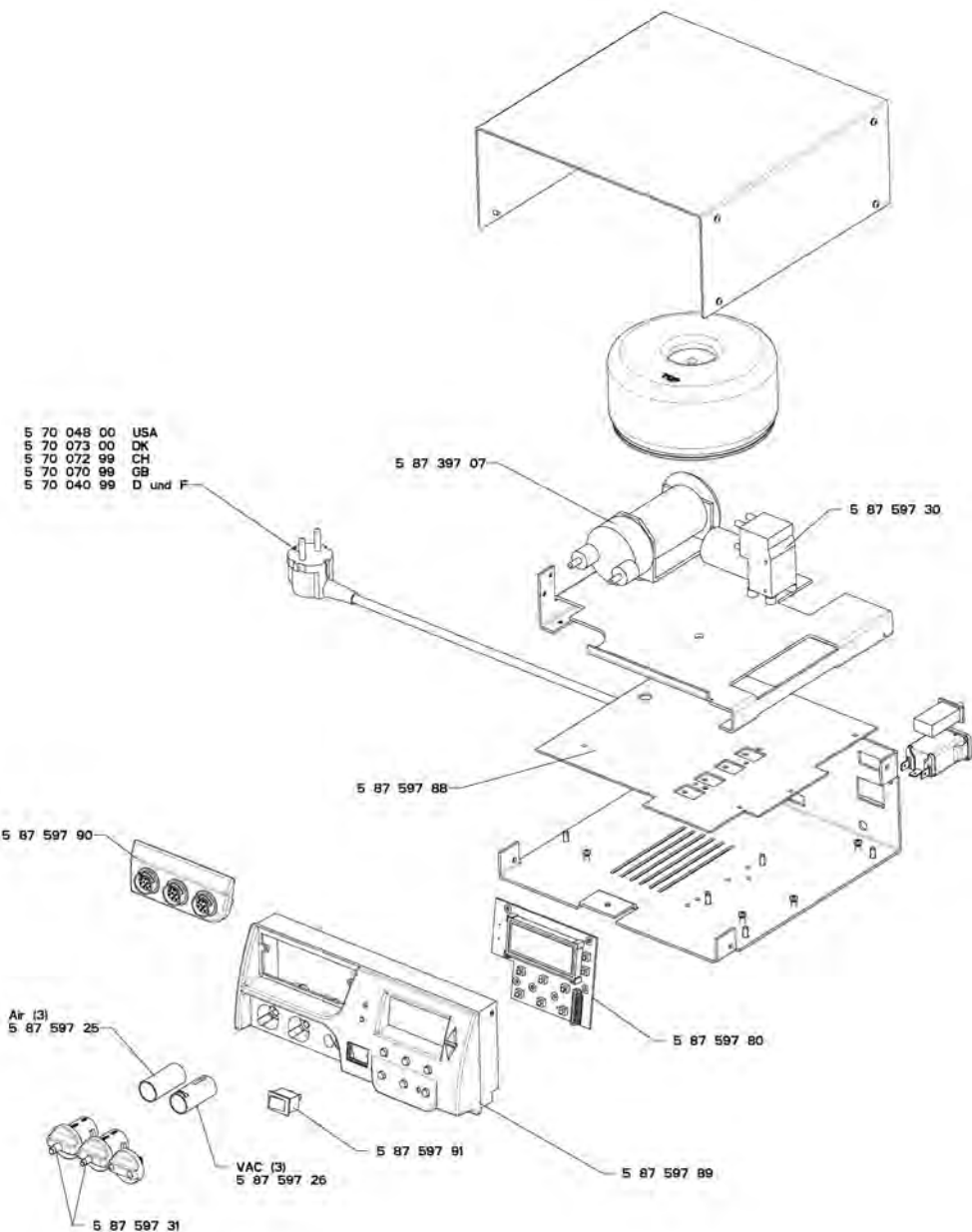

## GERMANY

Weller Tools GmbH  
Carl-Benz-Straße 2  
74354 Besigheim

Tel: +49 (0)7143 580-0  
Fax: +49 (0)7143 580-108

## SWEDEN

Apex Tool Group AB  
Fabriksgatan 4  
531 30 Lidköping

Tel: +46 (0) 510 77 71 720

## AUSTRALIA

Apex Tools  
P.O. Box 366, 519 Nurigong Street  
Albury, N.S.W. 2640  
Australia

Tel: +61 (2)6058-0300  
Fax: +61 (2)6021-7403

## ITALY

Apex Tool S.r.l.  
Viale Europa 80  
20090 Cusago (MI)

Tel: +39 (02)9033101  
Fax: +39 (02)90394231

## SWITZERLAND

Apex Tool Switzerland Sàrl  
Crêt-St-Tombet 15  
2022 Bevaix

Tel: +41 (0) 24 426 12 06  
Fax: +41 (0) 24 425 09 77

## INDIA

Apex Tool Group India Pvt. Ltd.  
Regus business centre  
Level 2, Elegance, Room no. 214  
Mathura Road, Jasola  
New Dehli - 110025

## FRANCE

Apex Tool Group SNC  
25 Avenue Maurice Chevalier  
77832 Ozoir-la-Ferrière

Tel: +33 (0)1.64.43.22.00  
Fax: +33 (0)1.64.43.21.62

## USA

Apex Tool Group, LLC  
14600 York Rd. Suite A  
Sparks, MD 21152

Tel: +1 (800)688-8949  
Fax: +1 (800)234-0472

## CHINA

Apex Tool Group  
A-8 building  
No. 38 Dongsheng Road  
Heqing Industrial Park, Pudong  
Shanghai 201201

Tel: +86 (21)60880288  
Fax: +86 (21)60880289

## GREAT BRITAIN

Apex Tool Group (UK Operations) Ltd  
4th Floor Pennine House  
Washington, Tyne & Wear  
NE37 1LY

Tel: +44 (0) 191 419 7700  
Fax: +44 (0) 191 417 9421

## CANADA

Apex Tools – Canada  
5925 McLaughlin Rd.  
Mississauga, Ontario L5R 1B8

Tel. +1 (905) 501-4785  
Fax. +1 (905) 387-2640

## SOUTH EAST ASIA

Apex Power Tools India Pvt. Ltd.  
Gala No. 1, Plot No. 5  
S. No. 234, 235 & 245  
India land Global Industrial Park  
(Next to Tata Johnson Control)  
Taluka-Mulsi, Phase-I  
Hinjawadi Pune (411057)  
Maharashtra, India  
toolsindia@apextoolgroup.com

# Mouser Electronics

Authorized Distributor

Click to View Pricing, Inventory, Delivery & Lifecycle Information:

[Apex Tool Group:](#)

[WXR3003N](#)