



- HVDC 400A continuous
- Max. Switching current = 2000A
- AgSnO₂ contacts sealed in inert gas
- Magnet arc blowout
- Auxiliary contact option
- Female M6 or M8 Male power terminals

Contacts

Contact arrangement	SPST-NO-DM	
Contact material	AgSnO ₂	
Max. switching voltage	AC/DC	1000VDC
Rated load	DC1	400A 1000VDC (break only above 200A)
Max. continuous thermal current	600s	500A (with 150mm ² conductors)
	60s	650A (with 150mm ² conductors)
Max switching current	1 time only	2000A 350VDC
Initial contact resistance	max.	1mΩ (at 1A)
Auxiliary contact (when fitted)	arrangement	SPST-NO (1 Form A), (SPST-NC by request)
	max. current	2A @ 30VDC / 3A @ 125VAC
	min. current	100mA @ 8V

Coil

Rated voltage (see page 2)	DC	9~36VDC (with coil economizer)
Rated power consumption	hold	1.56W @ 12VDC

Insulation

Insulation resistance	initial	100MΩ (min.)
	life end	50MΩ (min.)
Dielectric strength	coil to contact	2500Vrms / 1mA / 1 min (at sea level)
	contact to contact	2500Vrms / 1mA / 1 min (at sea level)

General Data

Operate / bounce time at 20°C	max.	25ms
Release time	max.	7ms
Electrical life	ops.	Voltage and current dependent - see fig. 1
Mechanical life	ops.	2 x 10 ⁵

Environmental

Environmental sealing	IP rating	Contacts are inside hermetically sealed can, economizer is protected by dust cover only.
Ambient temperature	operating	-40 to +85°C
Relative humidity		5 to 85%RH
Shock resistance		20G peak, 11ms 1/2 sine
Vibration resistance		20G sine peak (80 to 2000Hz)
Dimensions	L x W x H	58.2 x 80.48 (over flanges) x 72.11 (max.)
Weight	approx.	430g±10g



Ordering Code

D E V R 2 0 - 5 0 6 1 - S 8 - 0 9 3 6 - R 1

Series

Coil code:

See table 1

Contact material

50: AgSnO₂

Contact arrangement

61: SPST-NO*

71: SPST-NO* + Auxiliary

81: SPST-NO

91: SPST-NO +Auxiliary

* Polarized see page 2

Mounting & terminations

Bottom flange mounting base

S8: M8 male stud power terminals

S9: M6 female thread power terminals

Coil & auxiliary contacts by flying leads

Coil wire length

R: 14.96" (380mm)

T: 5.9" (150mm)

Coil wire & auxiliary contact termination

1: None

2: Yazaki 7282-5558-10 Male

Other terminations to special order

Coil Data

Table 1

Coil code	Nominal voltage (VDC)	Must operate voltage max. (VDC)	Max. allowable voltage (VDC)	Must release voltage min. (VDC)	Inrush Current Max. (A)	Hold Voltage Min. (VDC)	Holding Current (Average)
0936	9 - 36	9	36	6	3.8	7.5	130mA@12VDC 70mA @ 24VDC

Other coils available upon special request.

Electrical Performance

Fig. 1

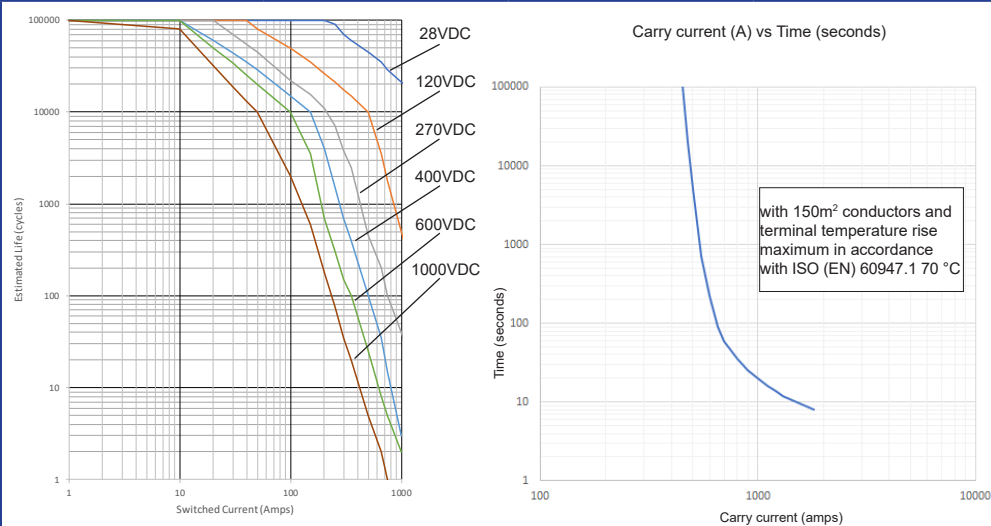

Estimates are based on tests and extrapolated data.
The user is advised to confirm the performance in their application.
For non-polarized contacts derate estimated life by 50%.

Circuit Diagram

Fig. 2

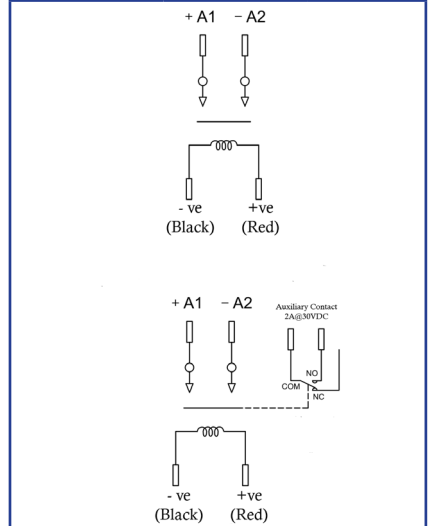

Power Terminals may be polarized or non-polarized depending upon chosen option.
Note: Coil is polarized.

Dimensions

Fig. 3

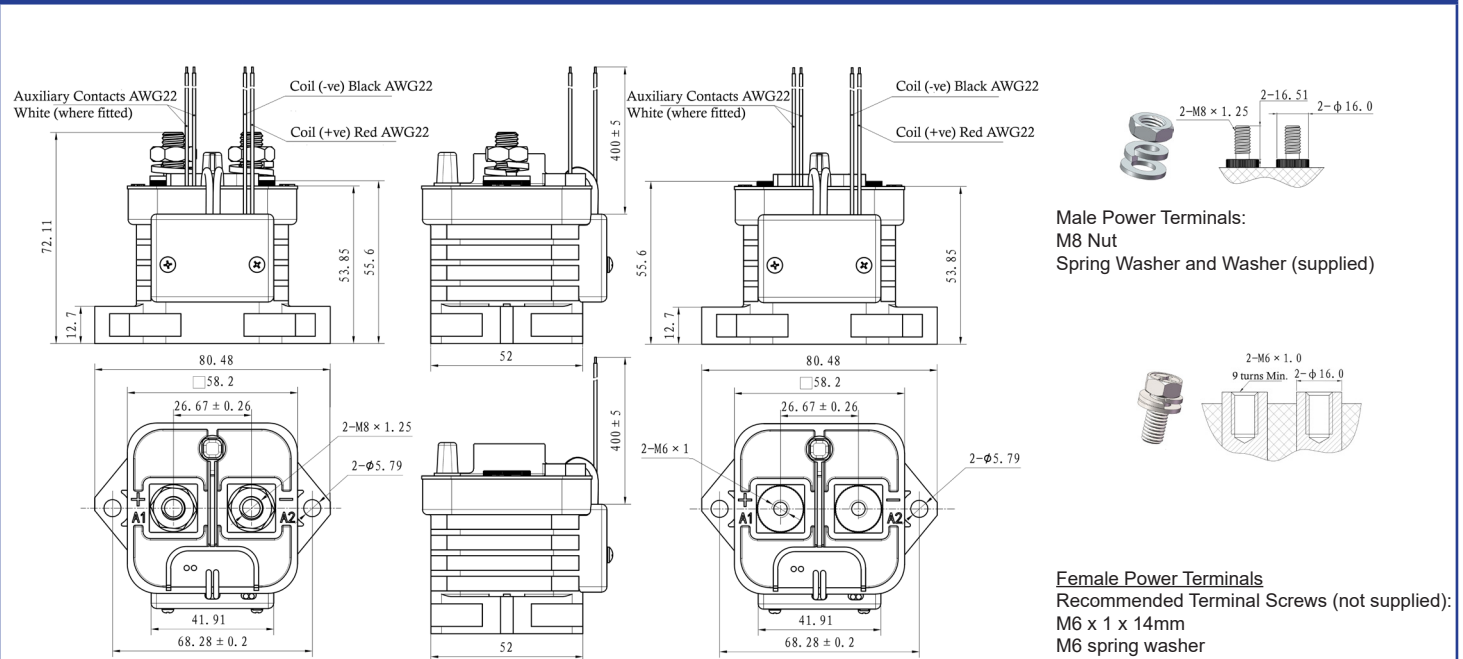

- Notes:
- Note coil polarity
 - Polarity sensitive type: Observe contact polarity as indicated.
Contactor life will be severely reduced if incorrectly connected.
 - Nominal dimensions in mm.
 - Tolerances (nominal), <10mm: ± 0.3mm, 10 ~ 50mm: ± 0.6mm, >50mm: ± 1.0mm.
 - Coil wire length and terminations can be customized upon request.

Male Power Terminals:
M8 Nut
Spring Washer and Washer (supplied)

Female Power Terminals
Recommended Terminal Screws (not supplied):
M6 x 1 x 14mm
M6 spring washer
M6 flat washer

Recommended Minimum Conductor
100mm².
Preferred conductor: 150mm²

Torque settings
Terminals: 9.0-12.0Nm
Base Mounting: 1.8 to 3.5Nm