

Freescale Semiconductor

 MPXV4006
 Rev 3, 1/2009

Integrated Silicon Pressure Sensor On-Chip Signal Conditioned, Temperature Compensated and Calibrated

The MPXV4006 series piezoresistive transducers are state-of-the-art monolithic silicon pressure sensors designed for the appliance, consumer, health care and industrial market. The analog output can be read directly into the A/D input of Freescale microcontrollers. This transducer combines advanced micromachining techniques, thin-film metallization, and bipolar processing to provide an accurate, high level analog output signal that is proportional to the applied pressure. The axial port has been modified to accommodate industrial grade tubing.

Features

- 2.5% Maximum Error over +10°C to +60°C with Auto Zero
- 5% Maximum Error over +10°C to +60°C without Auto Zero
- Durable Thermoplastic (PPS) Package
- Available in Surface Mount (SMT) or Through-Hole (DIP) Configurations
- Available with Standard Fluorosilicone Gel or Media Resistant Gel

**MPXV4006
Series
Integrated
Pressure Sensor**
0 to 6 kPa (0 to 0.87 psi)
0.2 to 4.8 V Output

Application Examples

- Washing Machine Water Level Measurement (Reference AN1950)
- Ideally Suited for Microprocessor or Microcontroller-Based Systems
- Appliance Liquid Level and Pressure Measurement
- Respiratory Equipment

ORDERING INFORMATION

Device Name	Package Options	Case No.	# of Ports			Pressure Type			Option		Device Marking
			None	Single	Dual	Gauge	Differential	Absolute	Surface Mount	Through-Hole	
Small Outline Package (Media Resistant Gel) (MPVZ4006 Series)											
MPVZ4006GW6U	Rail	1735		•		•			•		MZ4006GW
MPVZ4006GW7U	Rail	1560		•		•				•	MZ4006GW
MPVZ4006G6U	Rail	482	•				•		•		MPVZ4006G
MPVZ4006G6T1	Tape and Reel	482	•				•		•		MPVZ4006G
MPVZ4006G7U	Rail	482B	•				•			•	MPVZ4006G
Small Outline Package (MPXV4006 Series)											
MPXV4006GC6U	Rail	482A		•		•			•		MPXV4006G
MPXV4006GC6T1	Tape and Reel	482A		•		•			•		MPXV4006G
MPXV4006GC7U	Rail	482C		•		•				•	MPXV4006G
MPXV4006GP	Tray	1369		•		•			•		MPXV4006GP
MPXV4006DP	Tray	1351			•		•		•		MPXV4006DP

SMALL OUTLINE PACKAGE SURFACE MOUNT

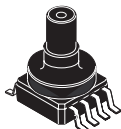

MPVZ4006GW6U
CASE 1735-01

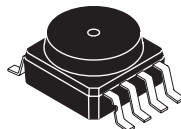

MPVZ4006G6U/T1
CASE 482-01

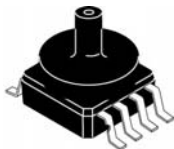

MPXV4006GC6U/C6T1
CASE 482A-01

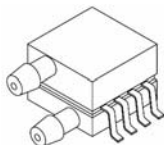

MPXV4006DP
CASE 1351-01

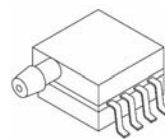

MPXV4006GP
CASE 1369-01

SMALL OUTLINE PACKAGE THROUGH-HOLE

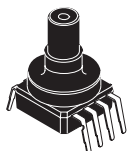

MPVZ4006GW7U
CASE 1560-02

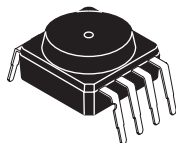

MPVZ4006G7U
CASE 482B-03

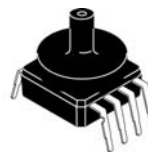

MPXV4006GC7U
CASE 482C-03

Operating Characteristics

Table 1. Operating Characteristics ($V_S = 5.0$ Vdc, $T_A = 25^\circ\text{C}$ unless otherwise noted, $P_1 > P_2$)

Characteristic	Symbol	Min	Typ	Max	Unit
Pressure Range	P_{OP}	0	—	6.0 612	kPa mm H ₂ O
Supply Voltage ⁽¹⁾	V_S	4.75	5.0	5.25	Vdc
Supply Current	I_S	—	—	10	mAdc
Full Scale Span ⁽²⁾	V_{FSS}	—	4.6	—	V
Offset ⁽³⁾⁽⁵⁾	V_{off}	0.152	0.265	0.378	V
Sensitivity	V/P	—	766 7.511	—	mV/kPa mV/mm H ₂ O
Accuracy ⁽⁴⁾⁽⁵⁾				±2.46	% V_{FSS} with auto zero
				±5.0	% V_{FSS} without auto zero

- Device is ratiometric within this specified excitation range.
- Full Scale Span (V_{FSS}) is defined as the algebraic difference between the output voltage at full rated pressure and the output voltage at the minimum rated pressure.
- Offset (V_{off}) is defined as the output voltage at the minimum rated pressure.
- Accuracy (error budget) consists of the following:
 - Linearity: Output deviation from a straight line relationship with pressure over the specified pressure range.
 - Temperature Hysteresis: Output deviation at any temperature within the operating temperature range, after the temperature is cycled to and from the minimum or maximum operating temperature points, with zero differential pressure applied.
 - Pressure Hysteresis: Output deviation at any pressure within the specified range, when this pressure is cycled to and from minimum or maximum rated pressure, at 25°C .
 - Offset Stability: Output deviation, after 1000 temperature cycles, -30 to 100°C , and 1.5 million pressure cycles, with minimum rated pressure applied.
 - TcSpan: Output deviation over the temperature range of 10° to 60°C , relative to 25°C .
 - TcOffset: Output deviation with minimum pressure applied, over the temperature range of 10° to 60°C , relative to 25°C .
- Auto Zero at Factory Installation: Due to the sensitivity of the MPXV4006, external mechanical stresses and mounting position can affect the zero pressure output reading. To obtain the 2.46% FSS accuracy, the device output must be "autozeroed" after installation. Autozeroing is defined as storing the zero pressure output reading and subtracting this from the device's output during normal operations. The specified accuracy assumes a maximum temperature change of $\pm 5^\circ\text{C}$ between autozero and measurement.

Maximum Ratings

Table 2. Maximum Ratings⁽¹⁾

Parametrics	Symbol	Value	Units
Maximum Pressure (P1 > P2)	P_{max}	24	kPa
Storage Temperature	T_{stg}	-30° to +100°	°C
Operating Temperature	T_A	+10° to +60°	°C

1. Exposure beyond the specified limits may cause permanent damage or degradation to the device.

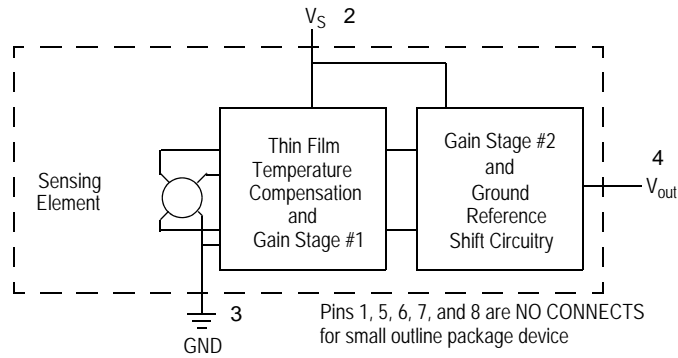

Figure 1. Fully Integrated Pressure Sensor Schematic

On-Chip Temperature Compensation and Calibration

The performance over temperature is achieved by integrating the shear-stress strain gauge, temperature compensation, calibration and signal conditioning circuitry onto a single monolithic chip.

Figure 2 illustrates the Differential or Gauge configuration in the basic chip carrier (Case 482). A gel die coat isolates the die surface and wire bonds from the environment, while allowing the pressure signal to be transmitted to the silicon diaphragm.

The MPXV4006/MPVZ4006 series sensor operating characteristics are based on use of dry air as pressure media. Media, other than dry air, may have adverse effects on sensor performance and long-term reliability. Internal reliability and

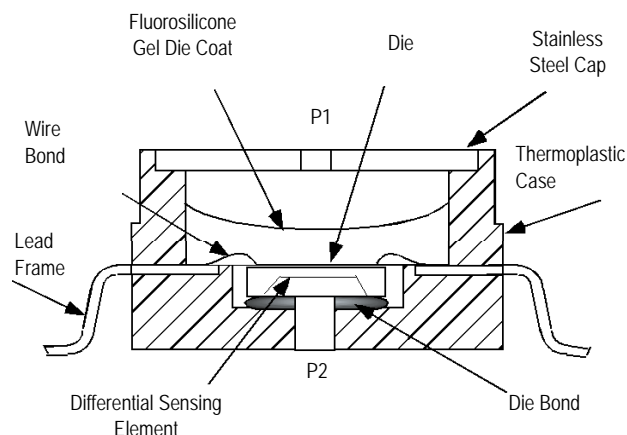

Figure 2. Cross Sectional Diagram SOP (not to scale)

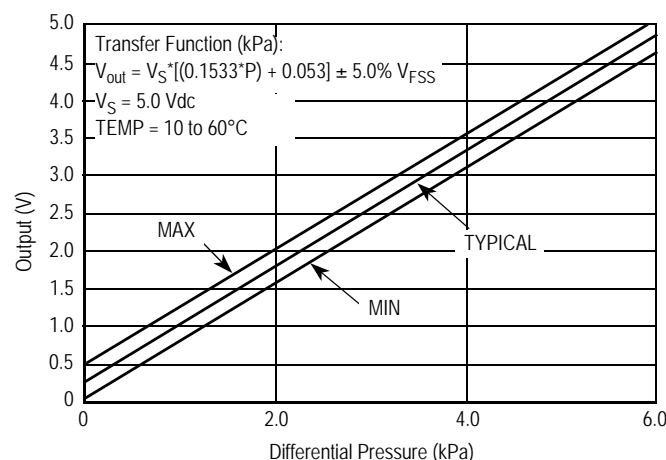

Figure 4. Output versus Pressure Differential at $\pm 5.0\%$ V_{FSS} (without auto zero, Note 5 in Operating Characteristics)

qualification test for dry air, and other media, are available from the factory. Contact the factory for information regarding media tolerance in your application.

Figure 3 shows the recommended decoupling circuit for interfacing the output of the integrated sensor to the A/D input of a microprocessor or microcontroller. Proper decoupling of the power supply is recommended.

Figure 4 and Figure 5 shows the sensor output signal relative to pressure input. Typical, minimum and maximum output curves are shown for operation over a temperature range of 10°C to 60°C using the decoupling circuit shown in Figure 3. The output will saturate outside of the specified pressure range.

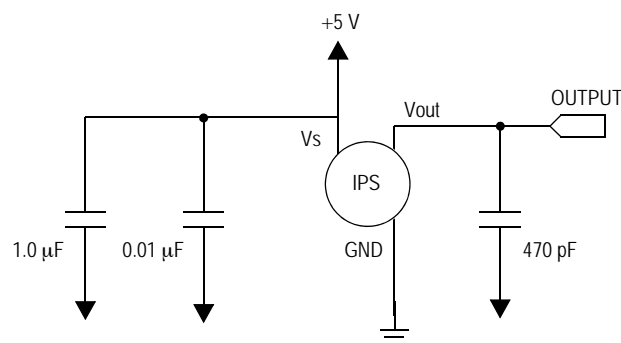

Figure 3. Recommended Power Supply Decoupling and Output Filtering Recommendations (For additional output filtering, please refer to Application Note AN1646.)

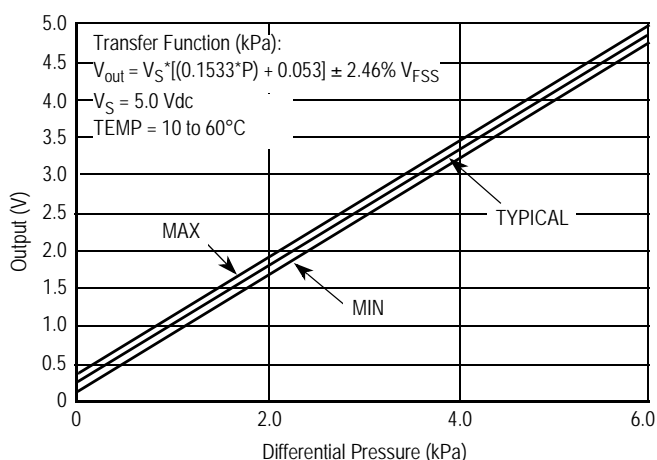

Figure 5. Output versus Pressure Differential at $\pm 2.46\%$ V_{FSS} (with auto zero, Note 5 in Operating Characteristics)

PRESSURE (P1)/VACUUM (P2) SIDE IDENTIFICATION TABLE

Freescale designates the two sides of the pressure sensor as the Pressure (P1) side and the Vacuum (P2) side. The Pressure (P1) side is the side containing a gel die coat which isolates the die from the environment. The pressure sensor is

designed to operate with positive differential pressure applied, P1 > P2.

The Pressure (P1) side may be identified by using the table below:

Table 3. Pressure (P1)/Vacuum (P2) Side Identification Table

Part Number	Case Type	Pressure (P1) Side Identifier
MPVZ4006GW6U	1735-01	Vertical Port Attached
MPVZ4006GW7U	1560-02	Vertical Port Attached
MPVZ4006G6U/T1	482-01	Stainless Steel Cap
MPVZ4006G7U	482B-03	Stainless Steel Cap
MPXV4006GC6U/T1	482A	Vertical Port Attached
MPXV4006GC7U	482C-03	Vertical Port Attached
MPXV4006GP	1369-01	Side with Port Attached
MPXV4006DP	1351-01	Side with Part Marking

MINIMUM RECOMMENDED FOOTPRINT FOR SURFACE MOUNTED APPLICATIONS

Surface mount board layout is a critical portion of the total design. The footprint for the surface mount packages must be the correct size to ensure proper solder connection interface between the board and the package. With the correct

footprint, the packages will self align when subjected to a solder reflow process. It is always recommended to design boards with a solder mask layer to avoid bridging and shorting between solder pads.

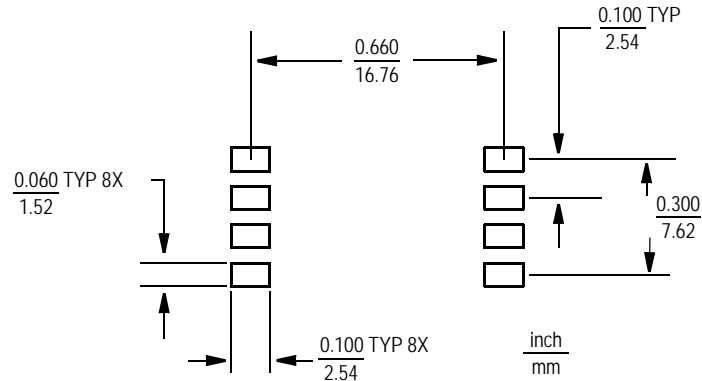
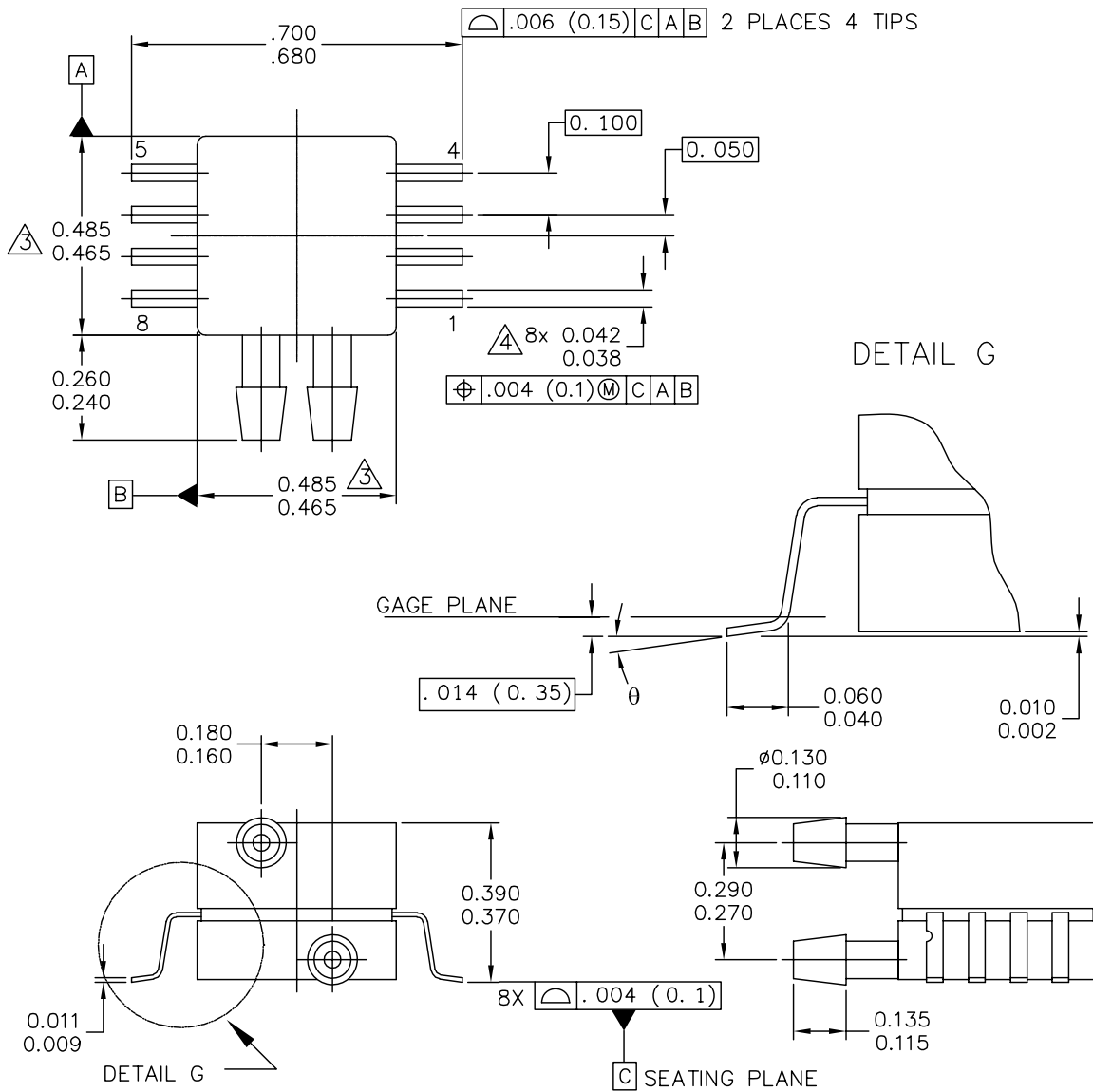

Figure 6. SOP Footprint (Case 482)



© FREESCALE SEMICONDUCTOR, INC. ALL RIGHTS RESERVED.	MECHANICAL OUTLINE	PRINT VERSION NOT TO SCALE
TITLE: 8 LD SNSR, DUAL PORT	DOCUMENT NO: 98ASA99255D	REV: A
	CASE NUMBER: 1351-01	27 JUL 2005
	STANDARD: NON-JEDEC	

**CASE 1351-01
ISSUE A
SMALL OUTLINE PACKAGE**

NOTES:

- 1. CONTROLLING DIMENSION: INCH
- 2. INTERPRET DIMENSIONS AND TOLERANCES PER ASME Y14.5M-1994.
- 3. DIMENSIONS DO NOT INCLUDE MOLD FLASH OR PROTRUSIONS. MOLD FLASH AND PROTRUSIONS SHALL NOT EXCEED .006 PER SIDE.
- 4. DIMENSION DOES NOT INCLUDE DAMBAR PROTRUSION. ALLOWABLE DAMBAR PROTRUSION SHALL BE .008 MAXIMUM.

STYLE 1:

PIN 1: GND
 PIN 2: +Vout
 PIN 3: Vs
 PIN 4: -Vout
 PIN 5: N/C
 PIN 6: N/C
 PIN 7: N/C
 PIN 8: N/C

STYLE 2:

PIN 1: N/C
 PIN 2: Vs
 PIN 3: GND
 PIN 4: Vout
 PIN 5: N/C
 PIN 6: N/C
 PIN 7: N/C
 PIN 8: N/C

© FREESCALE SEMICONDUCTOR, INC. ALL RIGHTS RESERVED.	MECHANICAL OUTLINE	PRINT VERSION NOT TO SCALE	
TITLE: 8 LD SNSR, DUAL PORT	DOCUMENT NO: 98ASA99255D	REV: A	
	CASE NUMBER: 1351-01	27 JUL 2005	
	STANDARD: NON-JEDEC		

**CASE 1351-01
 ISSUE A
 SMALL OUTLINE PACKAGE**

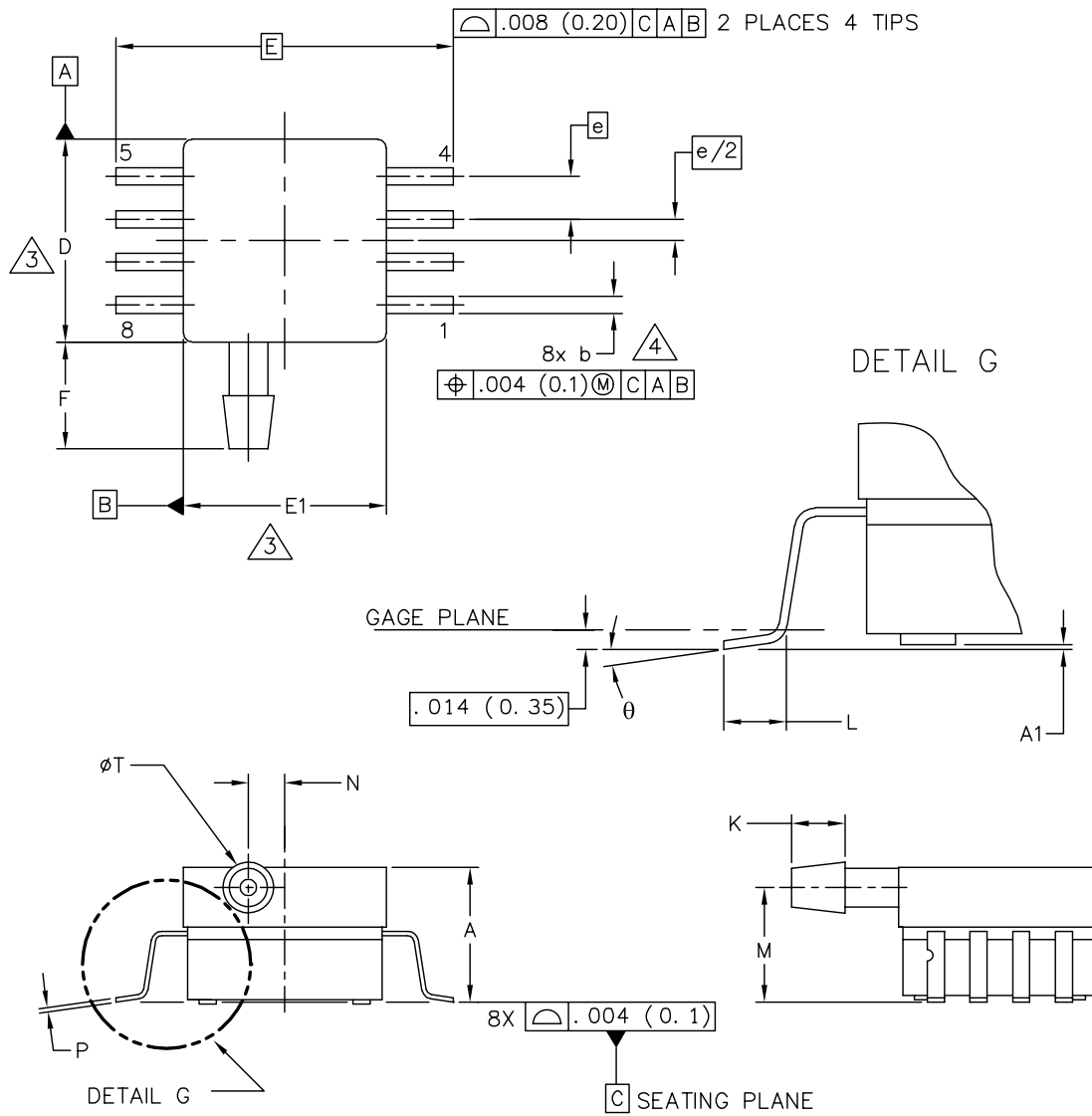

© FREESCALE SEMICONDUCTOR, INC. ALL RIGHTS RESERVED.	MECHANICAL OUTLINE	PRINT VERSION NOT TO SCALE	
TITLE: 8 LD SOP, SIDE PORT	DOCUMENT NO: 98ASA99303D	REV: B	
	CASE NUMBER: 1369-01	24 MAY 2005	
	STANDARD: NON-JEDEC		

**CASE 1369-01
ISSUE B
SMALL OUTLINE PACKAGE**

NOTES:

1. CONTROLLING DIMENSION: INCH
2. INTERPRET DIMENSIONS AND TOLERANCES PER ASME Y14.5M-1994.
3. DIMENSIONS DO NOT INCLUDE MOLD FLASH OR PROTRUSIONS. MOLD FLASH AND PROTRUSIONS SHALL NOT EXCEED .006 (0.152) PER SIDE.
4. DIMENSION DOES NOT INCLUDE DAMBAR PROTRUSION. ALLOWABLE DAMBAR PROTRUSION SHALL BE .008 (0.203) MAXIMUM.

DIM	INCHES		MILLIMETERS		DIM	INCHES		MILLIMETERS	
	MIN	MAX	MIN	MAX		MIN	MAX	MIN	MAX
A	.300	.330	7.11	7.62	θ	0°	7°	0°	7°
A1	.002	.010	0.05	0.25	-	---	---	---	---
b	.038	.042	0.96	1.07	-	---	---	---	---
D	.465	.485	11.81	12.32	-	---	---	---	---
E	.717 BSC		18.21 BSC		-	---	---	---	---
E1	.465	.485	11.81	12.32	-	---	---	---	---
e	.100 BSC		2.54 BSC		-	---	---	---	---
F	.245	.255	6.22	6.47	-	---	---	---	---
K	.120	.130	3.05	3.30	-	---	---	---	---
L	.061	.071	1.55	1.80	-	---	---	---	---
M	.270	.290	6.86	7.36	-	---	---	---	---
N	.080	.090	2.03	2.28	-	---	---	---	---
P	.009	.011	0.23	0.28	-	---	---	---	---
T	.115	.125	2.92	3.17	-	---	---	---	---
© FREESCALE SEMICONDUCTOR, INC. ALL RIGHTS RESERVED.			MECHANICAL OUTLINE			PRINT VERSION NOT TO SCALE			
TITLE: 8 LD SOP, SIDE PORT					DOCUMENT NO: 98ASA99303D			REV: B	
					CASE NUMBER: 1369-01			24 MAY 2005	
					STANDARD: NON-JEDEC				

**CASE 1369-01
ISSUE B
SMALL OUTLINE PACKAGE**

PACKAGE DIMENSIONS

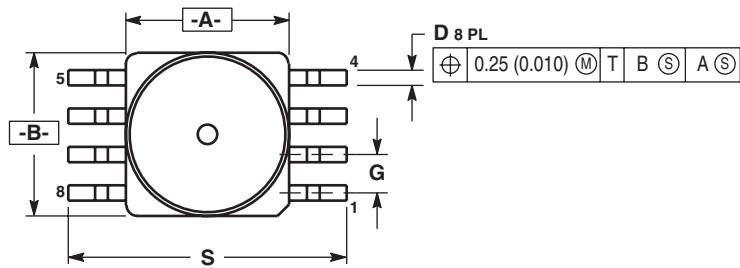

D 8 PL

\oplus	0.25 (0.010)	(M)	T	B	(S)	A	(S)
----------	--------------	-----	---	---	-----	---	-----

- NOTES:
1. DIMENSIONING AND TOLERANCING PER ANSI Y14.5M, 1982.
 2. CONTROLLING DIMENSION: INCH.
 3. DIMENSION A AND B DO NOT INCLUDE MOLD PROTRUSION.
 4. MAXIMUM MOLD PROTRUSION 0.15 (0.006).
 5. ALL VERTICAL SURFACES 5° TYPICAL DRAFT.

DIM	INCHES		MILLIMETERS	
	MIN	MAX	MIN	MAX
A	0.415	0.425	10.54	10.79
B	0.415	0.425	10.54	10.79
C	0.212	0.230	5.38	5.84
D	0.038	0.042	0.96	1.07
G	0.100 BSC		2.54 BSC	
H	0.002	0.010	0.05	0.25
J	0.009	0.011	0.23	0.28
K	0.061	0.071	1.55	1.80
M	0°	7°	0°	7°
N	0.405	0.415	10.29	10.54
S	0.709	0.725	18.01	18.41

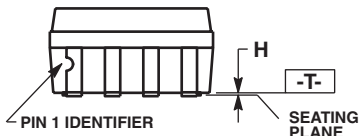
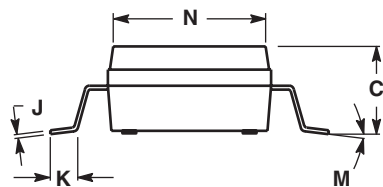

CASE 482-01
ISSUE O
SMALL OUTLINE PACKAGE

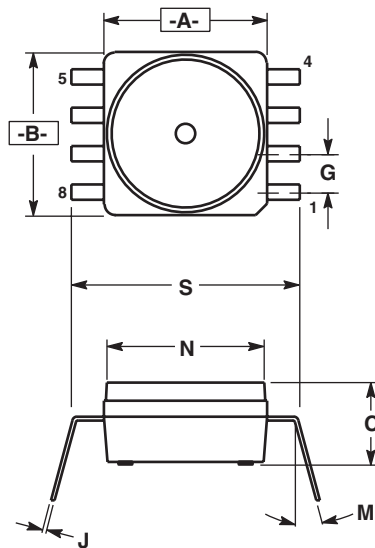

D 8 PL

\oplus	0.25 (0.010)	(M)	T	B	(S)	A	(S)
----------	--------------	-----	---	---	-----	---	-----

- NOTES:
1. DIMENSIONING AND TOLERANCING PER ANSI Y14.5M, 1982.
 2. CONTROLLING DIMENSION: INCH.
 3. DIMENSION A AND B DO NOT INCLUDE MOLD PROTRUSION.
 4. MAXIMUM MOLD PROTRUSION 0.15 (0.006).
 5. ALL VERTICAL SURFACES 5° TYPICAL DRAFT.
 6. DIMENSION S TO CENTER OF LEAD WHEN FORMED PARALLEL.

DIM	INCHES		MILLIMETERS	
	MIN	MAX	MIN	MAX
A	0.415	0.425	10.54	10.79
B	0.415	0.425	10.54	10.79
C	0.210	0.220	5.33	5.59
D	0.026	0.034	0.66	0.864
G	0.100 BSC		2.54 BSC	
J	0.009	0.011	0.23	0.28
K	0.100	0.120	2.54	3.05
M	0°	15°	0°	15°
N	0.405	0.415	10.29	10.54
S	0.540	0.560	13.72	14.22

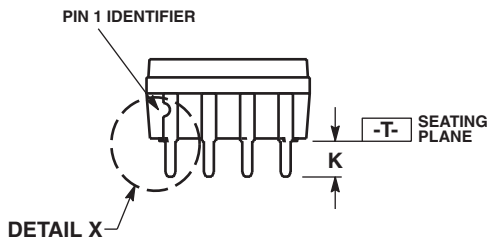

CASE 482B-03
ISSUE B
SMALL OUTLINE PACKAGE

PACKAGE DIMENSIONS

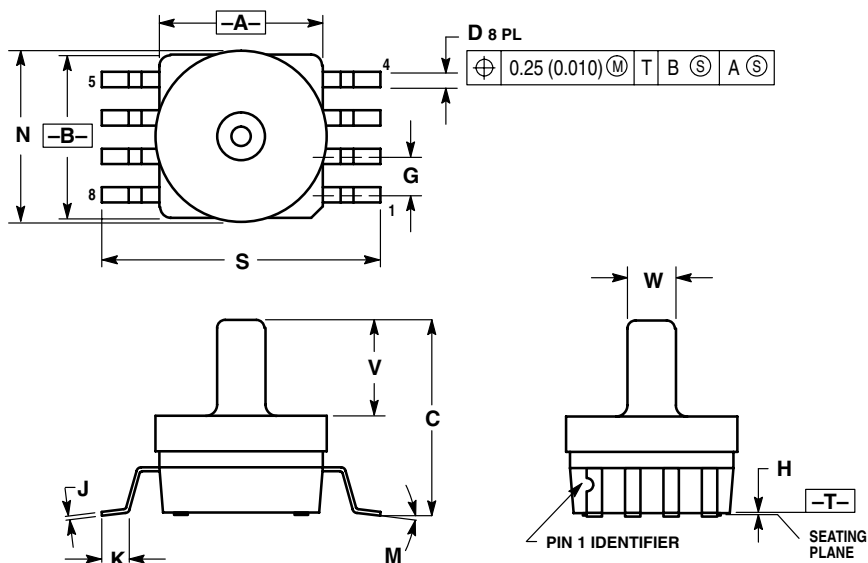

- NOTES:
1. DIMENSIONING AND TOLERANCING PER ANSI Y14.5M, 1982.
 2. CONTROLLING DIMENSION: INCH.
 3. DIMENSION A AND B DO NOT INCLUDE MOLD PROTRUSION.
 4. MAXIMUM MOLD PROTRUSION 0.15 (0.006).
 5. ALL VERTICAL SURFACES 5° TYPICAL DRAFT.

DIM	INCHES		MILLIMETERS	
	MIN	MAX	MIN	MAX
A	0.415	0.425	10.54	10.79
B	0.415	0.425	10.54	10.79
C	0.500	0.520	12.70	13.21
D	0.038	0.042	0.96	1.07
G	0.100 BSC		2.54 BSC	
H	0.002	0.010	0.05	0.25
J	0.009	0.011	0.23	0.28
K	0.061	0.071	1.55	1.80
M	0°	7°	0°	7°
N	0.444	0.448	11.28	11.38
S	0.709	0.725	18.01	18.41
V	0.245	0.255	6.22	6.48
W	0.115	0.125	2.92	3.17

**CASE 482A-01
 ISSUE A
 SMALL OUTLINE PACKAGE**

PACKAGE DIMENSIONS

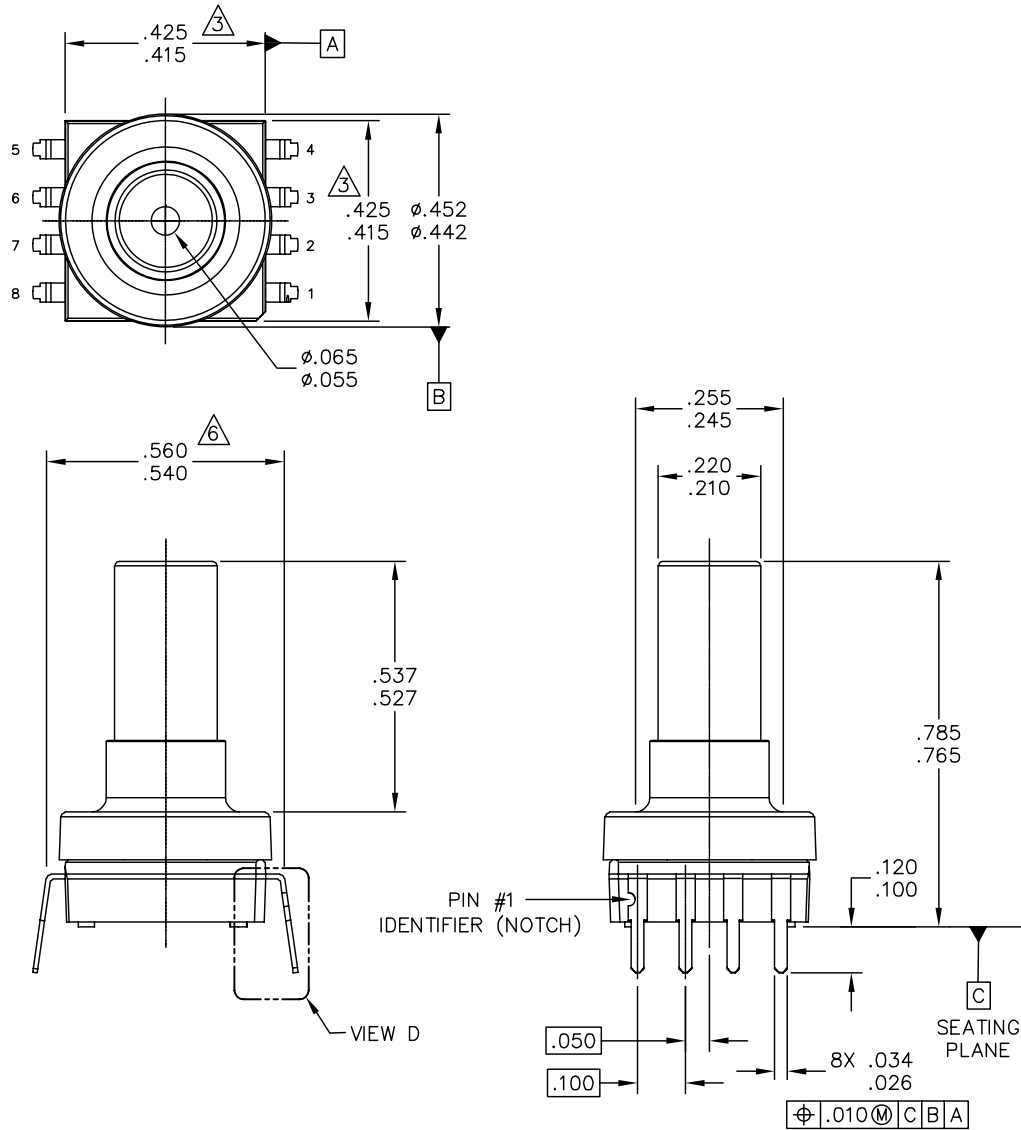

© FREESCALE SEMICONDUCTOR, INC. ALL RIGHTS RESERVED.	MECHANICAL OUTLINE	PRINT VERSION NOT TO SCALE
TITLE: SO, 8 I/O, .420 X .420 PKG, .100 IN PITCH	DOCUMENT NO: 98ASA10611D	REV: C
	CASE NUMBER: 1560-02	26 MAY 2005
	STANDARD: NON-JEDEC	

CASE 1560-02
ISSUE C
SMALL OUTLINE PACKAGE

PACKAGE DIMENSIONS

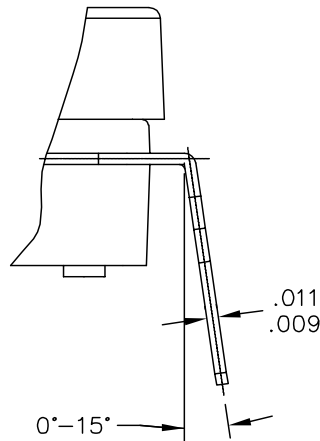

VIEW D

© FREESCALE SEMICONDUCTOR, INC. ALL RIGHTS RESERVED.	MECHANICAL OUTLINE	PRINT VERSION NOT TO SCALE	
TITLE: SO, 8 I/O, .420 X .420 PKG, .100 IN PITCH	DOCUMENT NO: 98ASA10611D	REV: C	
	CASE NUMBER: 1560-02	26 MAY 2005	
	STANDARD: NON-JEDEC		

**CASE 1560-02
ISSUE C
SMALL OUTLINE PACKAGE**

PACKAGE DIMENSIONS

NOTES:

1. DIMENSIONING AND TOLERANCING PER ASME Y14.5M – 1994.

2. CONTROLLING DIMENSION: INCH.

3. DIMENSIONS DO NOT INCLUDE MOLD PROTRUSION.

4. MAXIMUM MOLD PROTRUSION IS .006.

5. ALL VERTICAL SURFACES 5° TYPICAL DRAFT.

6. DIMENSION TO CENTER OF LEAD WHEN FORMED PARALLEL.

© FREESCALE SEMICONDUCTOR, INC. ALL RIGHTS RESERVED.	MECHANICAL OUTLINE	PRINT VERSION NOT TO SCALE	
TITLE: SO, 8 I/O, .420 X .420 PKG, .100 IN PITCH	DOCUMENT NO: 98ASA10611D	REV: C	
	CASE NUMBER: 1560-02	26 MAY 2005	
	STANDARD: NON-JEDEC		

CASE 1560-02
ISSUE C
SMALL OUTLINE PACKAGE

PACKAGE DIMENSIONS

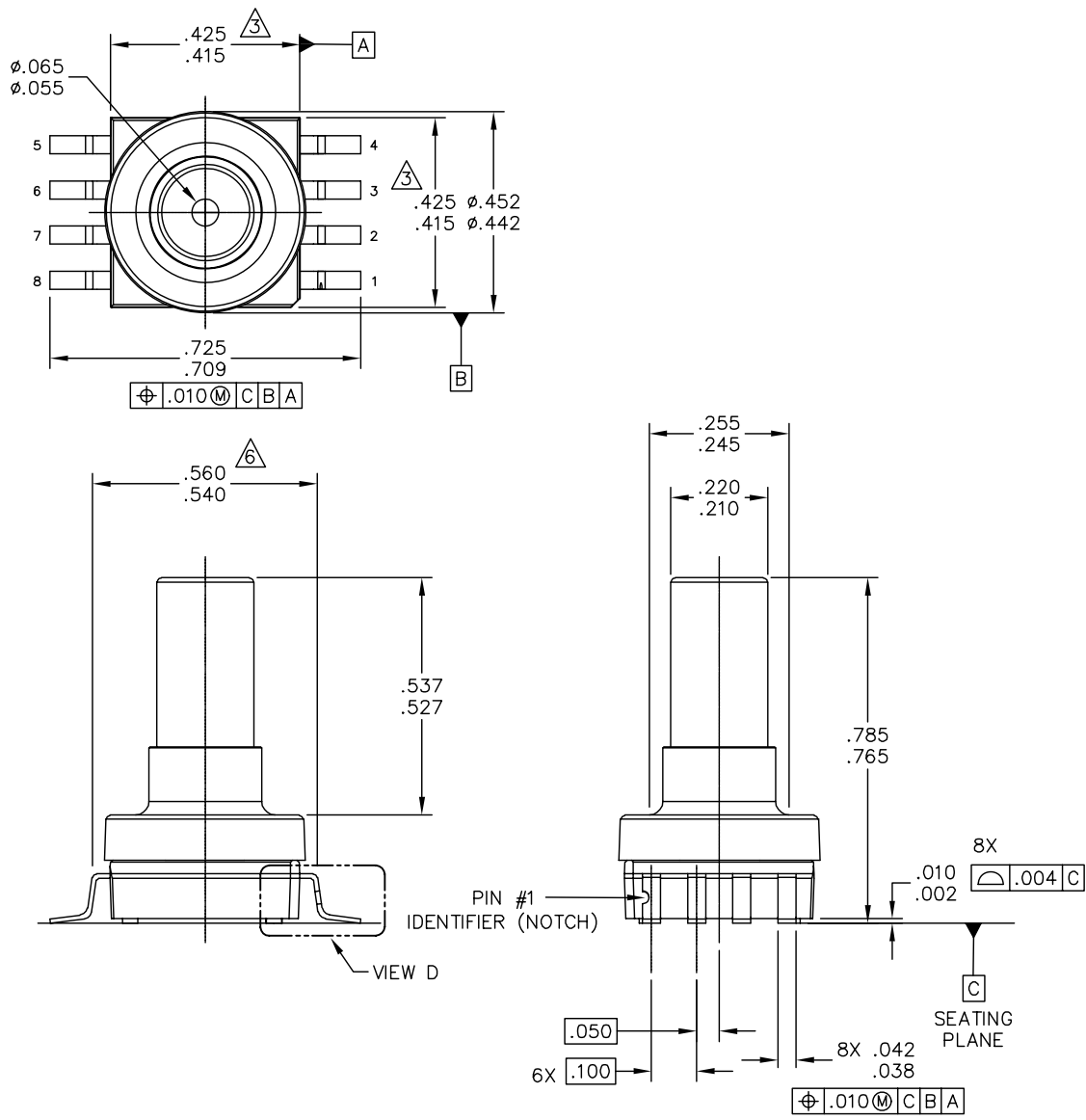

© FREESCALE SEMICONDUCTOR, INC. ALL RIGHTS RESERVED.	MECHANICAL OUTLINE	PRINT VERSION NOT TO SCALE	
TITLE: SO, 8 I/O, .420 X .420 PKG, .100 IN PITCH	DOCUMENT NO: 98ASA10686D	REV: A	
	CASE NUMBER: 1735-01	16 AUG 2005	
	STANDARD: NON-JEDEC		

**CASE 1735-01
ISSUE A
SMALL OUTLINE PACKAGE**

PACKAGE DIMENSIONS

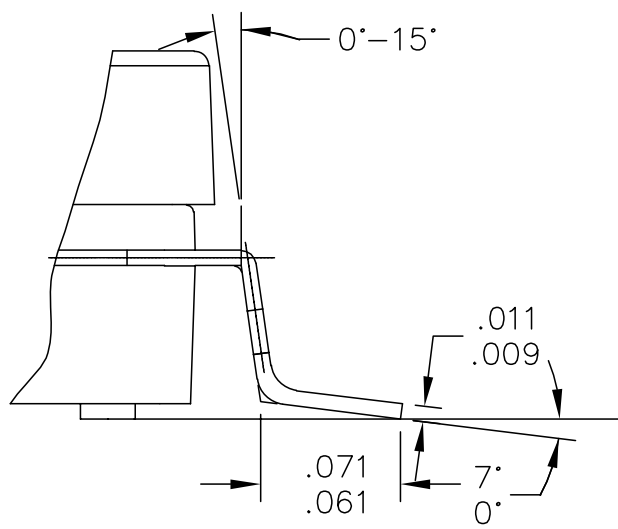

VIEW D

© FREESCALE SEMICONDUCTOR, INC. ALL RIGHTS RESERVED.	MECHANICAL OUTLINE	PRINT VERSION NOT TO SCALE	
TITLE: SO, 8 I/O, .420 X .420 PKG, .100 IN PITCH	DOCUMENT NO: 98ASA10686D	REV: A	
	CASE NUMBER: 1735-01	18 AUG 2005	
	STANDARD: NON-JEDEC		

**CASE 1735-01
ISSUE A
SMALL OUTLINE PACKAGE**

PACKAGE DIMENSIONS

NOTES:

1. DIMENSIONING AND TOLERANCING PER ASME Y14.5M – 1994.
2. CONTROLLING DIMENSION: INCH.
3. DIMENSIONS DO NOT INCLUDE MOLD PROTRUSION.
4. MAXIMUM MOLD PROTRUSION IS .006.
5. ALL VERTICAL SURFACES 5° TYPICAL DRAFT.
6. DIMENSION TO CENTER OF LEAD WHEN FORMED PARALLEL.

© FREESCALE SEMICONDUCTOR, INC. ALL RIGHTS RESERVED.	MECHANICAL OUTLINE	PRINT VERSION NOT TO SCALE	
TITLE: SO, 8 I/O, .420 X .420 PKG, .100 IN PITCH	DOCUMENT NO: 98ASA10686D	REV: A	
	CASE NUMBER: 1735-01	18 AUG 2005	
	STANDARD: NON-JEDEC		

**CASE 1735-01
ISSUE A
SMALL OUTLINE PACKAGE**

PACKAGE DIMENSIONS

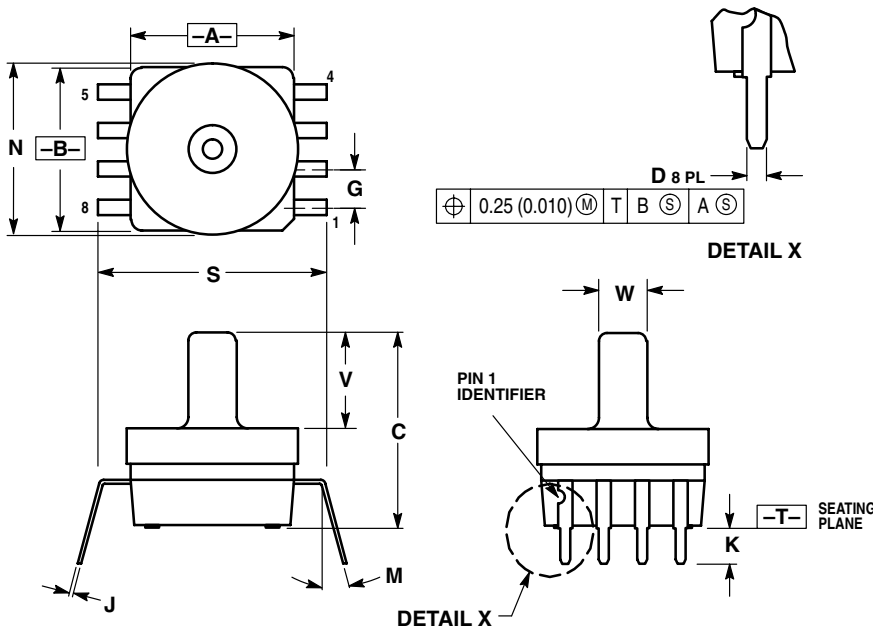

NOTES:

1. DIMENSIONING AND TOLERANCING PER ANSI Y14.5M, 1982.
2. CONTROLLING DIMENSION: INCH.
3. DIMENSION A AND B DO NOT INCLUDE MOLD PROTRUSION.
4. MAXIMUM MOLD PROTRUSION 0.15 (0.006).
5. ALL VERTICAL SURFACES 5° TYPICAL DRAFT.
6. DIMENSION S TO CENTER OF LEAD WHEN FORMED PARALLEL.

DIM	INCHES		MILLIMETERS	
	MIN	MAX	MIN	MAX
A	0.415	0.425	10.54	10.79
B	0.415	0.425	10.54	10.79
C	0.500	0.520	12.70	13.21
D	0.026	0.034	0.66	0.864
G	0.100 BSC		2.54 BSC	
J	0.009	0.011	0.23	0.28
K	0.100	0.120	2.54	3.05
M	0°	15°	0°	15°
N	0.444	0.448	11.28	11.38
S	0.540	0.560	13.72	14.22
V	0.245	0.255	6.22	6.48
W	0.115	0.125	2.92	3.17

CASE 482C-03
ISSUE A
SMALL OUTLINE PACKAGE

PACKAGE DIMENSIONS

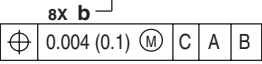
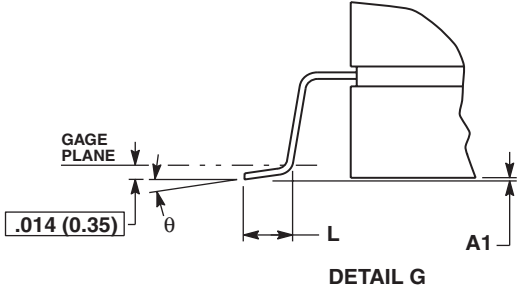
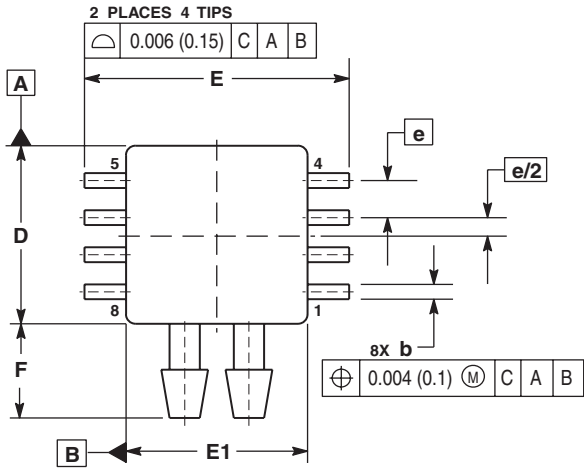

- STYLE 1:
 PIN 1. GND
 2. +Vout
 3. Vs
 4. -Vout
 5. N/C
 6. N/C
 7. N/C
 8. N/C
- STYLE 2:
 PIN 1. N/C
 2. Vs
 3. GND
 4. Vout
 5. N/C
 6. N/C
 7. N/C
 8. N/C

- NOTES:
1. CONTROLLING DIMENSION: INCH.
 2. INTERPRET DIMENSIONS AND TOLERANCES PER ASME Y14.5M, 1994.
 3. DIMENSIONS "D" AND "E1" DO NOT INCLUDE MOLD FLASH OR PROTRUSIONS. MOLD FLASH OR PROTRUSIONS SHALL NOT EXCEED 0.006 (0.152) PER SIDE.
 4. DIMENSION "b" DOES NOT INCLUDE DAMBAR PROTRUSION. ALLOWABLE DAMBAR PROTRUSION SHALL BE 0.008 (0.203) MAXIMUM.

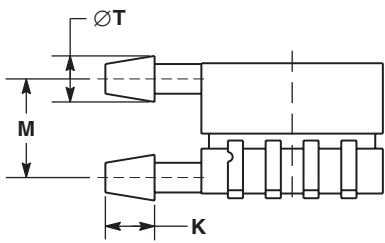
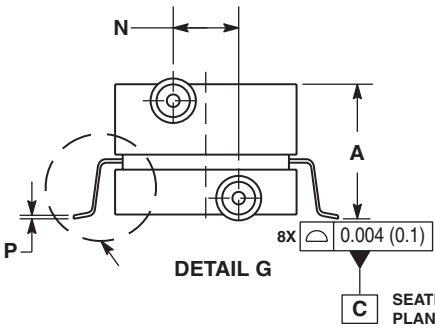

DIM	INCHES		MILLIMETERS	
	MIN	MAX	MIN	MAX
A	0.370	0.390	9.39	9.91
A1	0.002	0.010	0.05	0.25
b	0.038	0.042	0.96	1.07
D	0.465	0.485	11.81	12.32
E	0.680	0.700	17.27	17.78
E1	0.465	0.485	11.81	12.32
e	0.100 BSC		2.54 BSC	
F	0.240	0.260	6.10	6.60
K	0.115	0.135	2.92	3.43
L	0.040	0.060	1.02	1.52
M	0.270	0.290	6.86	7.37
N	0.160	0.180	4.06	4.57
P	0.009	0.011	0.23	0.28
T	0.110	0.130	2.79	3.30
θ	0°	7°	0°	7°

**CASE 1351-01
 ISSUE O
 SMALL OUTLINE PACKAGE**

PACKAGE DIMENSIONS

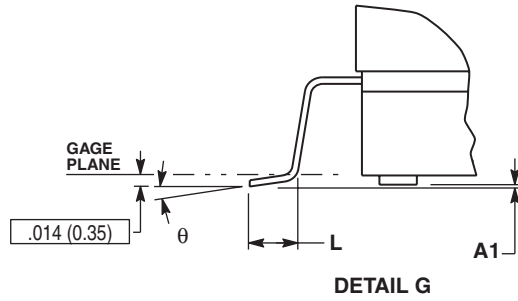
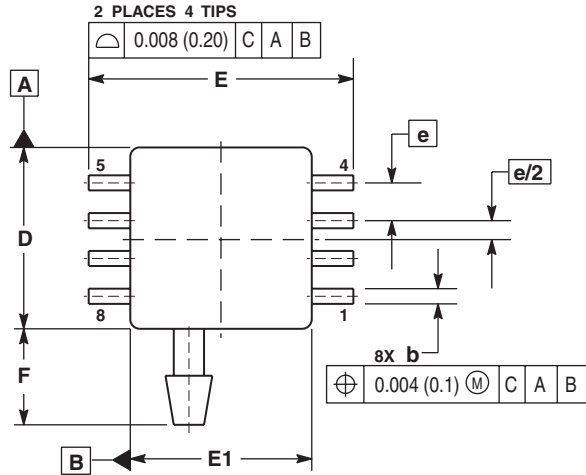

- NOTES:
1. CONTROLLING DIMENSION: INCH.
 2. INTERPRET DIMENSIONS AND TOLERANCES PER ASME Y14.5M, 1994.
 3. DIMENSIONS "D" AND "E1" DO NOT INCLUDE MOLD FLASH OR PROTRUSIONS. MOLD FLASH OR PROTRUSIONS SHALL NOT EXCEED 0.006 (0.152) PER SIDE.
 4. DIMENSION "b" DOES NOT INCLUDE DAMBAR PROTRUSION. ALLOWABLE DAMBAR PROTRUSION SHALL BE 0.008 (0.203) MAXIMUM.

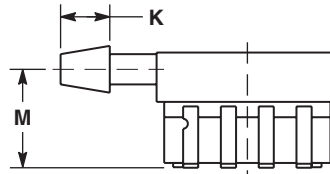
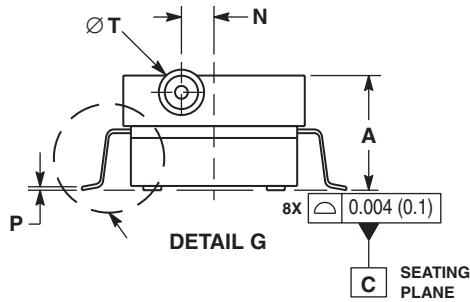

DIM	INCHES		MILLIMETERS	
	MIN	MAX	MIN	MAX
A	0.300	0.330	7.11	7.62
A1	0.002	0.010	0.05	0.25
b	0.038	0.042	0.96	1.07
D	0.465	0.485	11.81	12.32
E	0.717 BSC		18.21 BSC	
E1	0.465	0.485	11.81	12.32
e	0.100 BSC		2.54 BSC	
F	0.245	0.255	6.22	6.47
K	0.120	0.130	3.05	3.30
L	0.061	0.071	1.55	1.80
M	0.270	0.290	6.86	7.36
N	0.080	0.090	2.03	2.28
P	0.009	0.011	0.23	0.28
T	0.115	0.125	2.92	3.17
θ	0°	7°	0°	7°

CASE 1369-01
ISSUE O
SMALL OUTLINE PACKAGE

How to Reach Us:

Home Page:

www.freescale.com

Web Support:

<http://www.freescale.com/support>

USA/Europe or Locations Not Listed:

Freescale Semiconductor, Inc.
Technical Information Center, EL516
2100 East Elliot Road
Tempe, Arizona 85284
1-800-521-6274 or +1-480-768-2130
www.freescale.com/support

Europe, Middle East, and Africa:

Freescale Halbleiter Deutschland GmbH
Technical Information Center
Schatzbogen 7
81829 Muenchen, Germany
+44 1296 380 456 (English)
+46 8 52200080 (English)
+49 89 92103 559 (German)
+33 1 69 35 48 48 (French)
www.freescale.com/support

Japan:

Freescale Semiconductor Japan Ltd.
Headquarters
ARCO Tower 15F
1-8-1, Shimo-Meguro, Meguro-ku,
Tokyo 153-0064
Japan
0120 191014 or +81 3 5437 9125
support.japan@freescale.com

Asia/Pacific:

Freescale Semiconductor China Ltd.
Exchange Building 23F
No. 118 Jianguo Road
Chaoyang District
Beijing 100022
China
+86 010 5879 8000
support.asia@freescale.com

For Literature Requests Only:

Freescale Semiconductor Literature Distribution Center
P.O. Box 5405
Denver, Colorado 80217
1-800-441-2447 or +1-303-675-2140
Fax: +1-303-675-2150
LDCForFreescaleSemiconductor@hibbertgroup.com

Information in this document is provided solely to enable system and software implementers to use Freescale Semiconductor products. There are no express or implied copyright licenses granted hereunder to design or fabricate any integrated circuits or integrated circuits based on the information in this document.

Freescale Semiconductor reserves the right to make changes without further notice to any products herein. Freescale Semiconductor makes no warranty, representation or guarantee regarding the suitability of its products for any particular purpose, nor does Freescale Semiconductor assume any liability arising out of the application or use of any product or circuit, and specifically disclaims any and all liability, including without limitation consequential or incidental damages. "Typical" parameters that may be provided in Freescale Semiconductor data sheets and/or specifications can and do vary in different applications and actual performance may vary over time. All operating parameters, including "Typicals", must be validated for each customer application by customer's technical experts. Freescale Semiconductor does not convey any license under its patent rights nor the rights of others. Freescale Semiconductor products are not designed, intended, or authorized for use as components in systems intended for surgical implant into the body, or other applications intended to support or sustain life, or for any other application in which the failure of the Freescale Semiconductor product could create a situation where personal injury or death may occur. Should Buyer purchase or use Freescale Semiconductor products for any such unintended or unauthorized application, Buyer shall indemnify and hold Freescale Semiconductor and its officers, employees, subsidiaries, affiliates, and distributors harmless against all claims, costs, damages, and expenses, and reasonable attorney fees arising out of, directly or indirectly, any claim of personal injury or death associated with such unintended or unauthorized use, even if such claim alleges that Freescale Semiconductor was negligent regarding the design or manufacture of the part.

Freescale™ and the Freescale logo are trademarks of Freescale Semiconductor, Inc. All other product or service names are the property of their respective owners.

© Freescale Semiconductor, Inc. 2009. All rights reserved.