

1	2	3	4						
COUNT	DESCRIPTION OF REVISIONS	BY	CHKD	DATE	COUNT	DESCRIPTION OF REVISIONS	BY	CHKD	DATE
△					△				
△					△				
△					△				

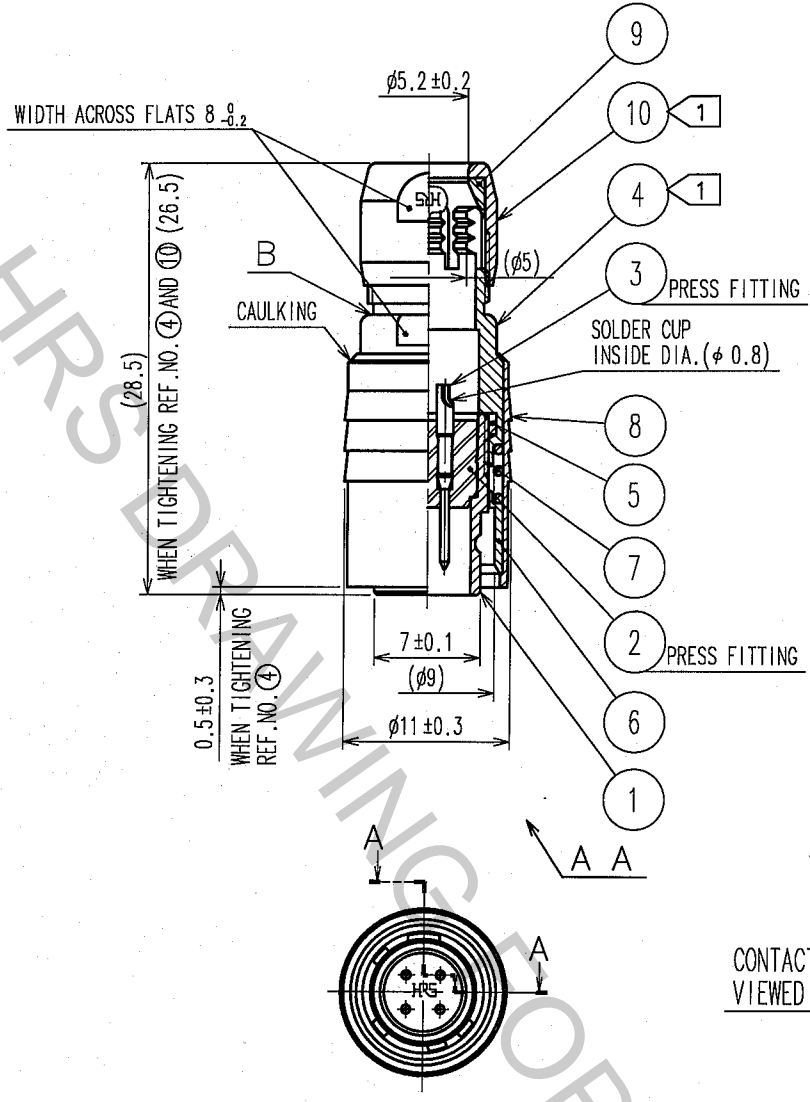

NOTE 1 THE RECOMMENDED CLAMP TORQUE, REF. NO. ④ AND ⑩ : 1.5 N · m.
 REF. NO. ⑩ SHALL BE TIGHTENED BY TORQUE AFTER CLAMPED UNTIL IT TOUCHES THE SURFACE B.
 2 ONE EXAMPLE OF THE ROTATION OF REF. NO. ①, ④ AND ⑩ IS SHOWN.

5	POLYAMIDE			9	POLYAMIDE	
4	BRASS	MATTE FINISH NICKEL PLATING	10	BRASS	MATTE FINISH NICKEL PLATING	
3	BRASS	GOLD PLATING 0.2μ m min. NICKEL UNDER PLATING 2μ m min.	8	BRASS	MATTE FINISH NICKEL PLATING	
2	POLYAMIDE	(BLUE)	7	STEEL	NICKEL PLATING	
1	ZINC ALLOY	MATTE FINISH NICKEL PLATING	6	STAINLESS STEEL		
NO.	MATERIAL	FINISH, REMARKS	NO.	MATERIAL	FINISH, REMARKS	

CODE NO. (OLD) CL		DRAWN <i>D. Matsume</i> 05.09.01	DESIGNED <i>D. Matsume</i> 05.09.01	CHECKED <i>H. Kishi</i> 105.09.01	APPROVED <i>M. Sato</i> 05.09.02	RELEASED
DRAWING NO. EDC4-007756-73		PART NO. HR10-7P-4P(73)				
SACLE 2 : 1		CODE NO. CL110-0021-6-73				1/1
UNITS mm		HIROSE ELECTRIC CO., LTD.				

TO
R

